

ISO 9001:2015 by L.R.
PED DIR. 2014/68/UE by L.R.
ATEX DIR. 2014/34/UE by B.V.
FIRE SAFE EXECUTION by L.R.
ISO 15848 by TÜV
ANTISTATIC DEVICE by L.R.
FIRE SAFE TESTED ISO 10497 by L.R.
EAC CERTIFICATION by B.V.

TYPE
FM2
PN 10 ÷ 40

NORME E DIRETTIVE APPLICATE DISPONIBILI AL SEGUENTE LINK:
STANDARD AND DIRECTIVE APPLIED AVAILABLE AT FOLLOWING LINK:
http://www.adlerspa.com/pdf/NORME_ADLER.pdf

VALVOLE A SFERA "UNI EN 558-1" SPLIT BODY PASSAGGIO TOTALE

ISO nbr° LRC 0160281 QMS issued by L.R.Q.A. PED nbr° COV 0212112/01 issued by L.R.V.
ATEX nbr° 40.2003.4392 issued by B.V. ISO 15848 nbr° I-148466/1-/2 issued by TÜV

On request
S.I.L. 3
According to IEC 61508

On request
Certified for cryogenic
service according to
ISO 28921-2

On request
Certified
TPED 2010/35/UE
ADR/RID/ADNR 2019
EN 14432-2014
FROM DN 15 TO DN 100 PN 40

On request
FIRE SAFE
According to ISO 10497
"ISO-FT"

FULL BORE ACCORDING TO
ISO 14313

CONSTRUCTION ACCORDING TO:
BS EN 12516-2 - ISO 14313
UNI EN 558-1

BALL VALVES
"UNI EN 558-1" FULL BORE SPLIT BODY
ROBINETS A BOISSEAU SPHERIQUE
"UNI EN 558-1" PASSAGE INTEGRAL 2 PIECES
FLANSCHKUGELHÄHNE IN "UNI EN 558-1"
VOLLER DURCHGANG ZWEITEILIGES GEHÄUSE

WEB SITE: WWW.ADLERSPA.COM

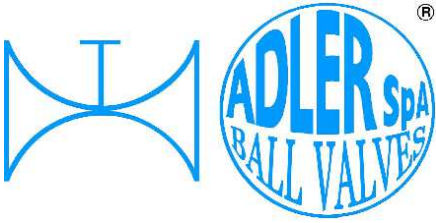

ISO 9001:2015 by L.R.
 PED DIR. 2014/68/UE by L.R.
 ATEX DIR. 2014/34/UE by B.V.
 FIRE SAFE EXECUTION by L.R.
 ISO 15848 by TÜV
 ANTISTATIC DEVICE by L.R.
 FIRE SAFE TESTED ISO 10497 by L.R.
 EAC CERTIFICATION by B.V.

TYPE
FM2
 PN 10 ÷ 40

VALVOLA A SFERA "UNI EN 558-1" SPLIT BODY PASSAGGIO TOTALE
 BALL VALVES "UNI EN 558-1" SPLIT BODY FULL BORE
 ROBINETS A BOISSEAU SPHERIQUE "UNI EN 558-1" PASSAGE INTEGRAL 2 PIECES
 FLANSCHKUGELHÄHNE IN "UNI EN 558-1" VOLLER DURCHGANG ZWEITEILIGES GEHÄUSE

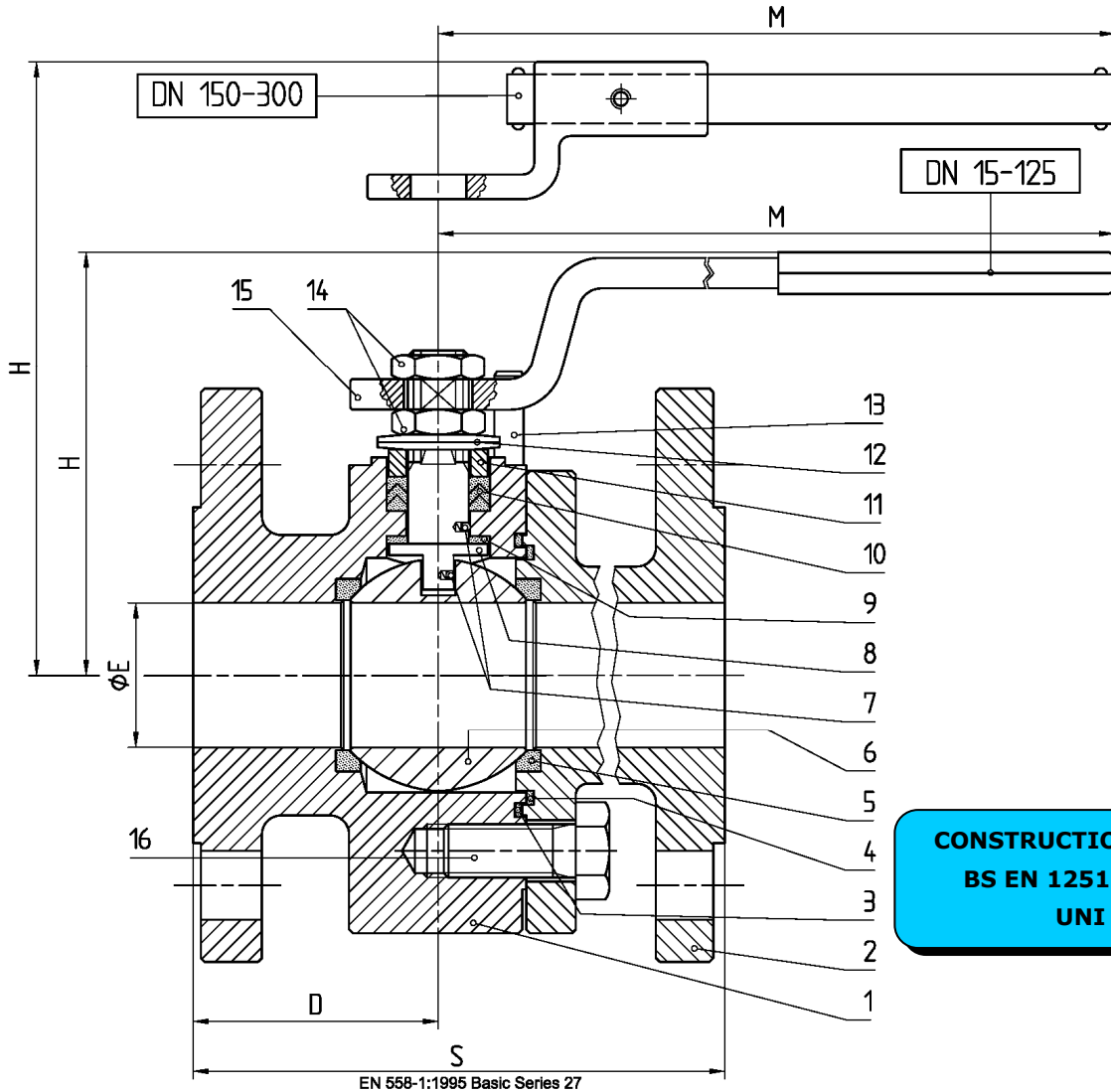

DN 200 ÷ 300
 -CONSIGLIATO
 RIDUTTORE MANUALE
 -MANUAL GEAR BOX
 SUGGESTED
 -REDUCTEUR MANUEL
 CONSEILLE
 -EMPFEHLEN WIR EIN
 HANDGETRIEBE

CONSTRUCTION ACCORDING TO:
 BS EN 12516-2 - ISO 14313
 UNI EN 558-1

ADLER BALL VALVES FM2/19 RIPRODUZIONE VIETATA - COPYRIGHT

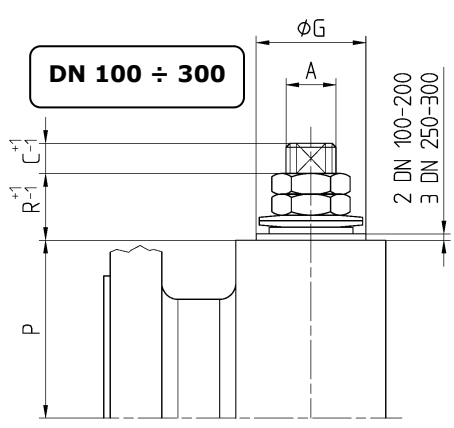

• ACCOPPIAMENTO VALVOLA
 ATTUATORE
 • CONNECTION VALVE
 ACTUATOR
 • ACCOUPLEMENT ROBINET-
 ACTIONNEUR
 • ZUSAMMENBAU KUGELHAHN
 ANTRIEB
ISO-5211

DN 100 ÷ 300

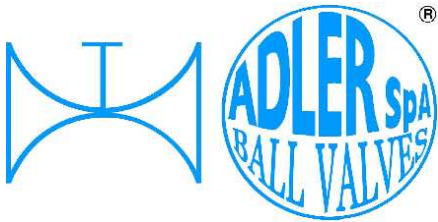

ISO 9001:2015 by L.R.
 PED DIR. 2014/68/UE by L.R.
 ATEX DIR. 2014/34/UE by B.V.
 FIRE SAFE EXECUTION by L.R.
 ISO 15848 by TÜV
 ANTISTATIC DEVICE by L.R.
 FIRE SAFE TESTED ISO 10497 by L.R.
 EAC CERTIFICATION by B.V.

TYPE
FM2
 PN 10 ÷ 40

N.	DESCRIZIONE DESCRIPTION DESCRIPTION BESCHREIBUNG	MATERIALI MATERIALS MATERIAUX WERKSTOFFE
1	CORPO BODY CORPS MITTE	ASTM A105 ASTM A479 304/304L ASTM A479 316/316L ASTM A 351 CF8M
2	LATERALE END LATERAL ENDE	ASTM A105 ASTM A479 304/304L ASTM A479 316/316L ASTM A 351 CF8M
3*	O-RING	FKM - (VITON)
4*	ANELLO SEAL ANNEAU DICHTUNGSRING	P.T.F.E.
5*	SEDE SEAT SIEGE SITZRING	P.T.F.E. (BAM CERTIFIED) R.P.T.F.E. (OPTIONAL)
6	SFERA BALL BOULE KUGEL	ASTM A479 304/304L ASTM A351 CF8 ASTM A479 316/316L ASTM A351 CF8M
7	DISPOSITIVO ANTISTATICO ANTISTATIC DEVICE CONTACT ANTISTATIQUE ANTISTATIK VORRICHTUNG	ASTM A479 316/316L
8	STELO STEM TIGE SPINDEL	ASTM A479 304/304L ASTM A479 316/316L

N.	DESCRIZIONE DESCRIPTION DESCRIPTION BESCHREIBUNG	MATERIALI MATERIALS MATERIAUX WERKSTOFFE
9*	BUSSOLA STEM SEAL JOINT TIGE UNTERE SPINDELABDICHTUNG	P.T.F.E.
10*	PACCO A "V" CHEVRON RINGS JOINT A "V" 3 FACHE DACHMANSCHETTE	P.T.F.E. / GRAFITE P.T.F.E. / GRAPHITE P.T.F.E. / GRAPHITE P.T.F.E. / GRAPHIT
11	PREMIBUSSOLA PRESSING BUSH PRESSE RONDELLE STOPFBUCHSDRUCKRING	ASTM A479 304
12	MOLLE A TAZZA SPRING WASHERS RONDELLES BELLEVILLE TELLERFEDERN	C72/50Cr V4 X5CrNi17.7 or X12CrNi17.7 ZINCATO - GALVANIZED - ZINGUE - VERZINKT ON REQUEST
13	VITE DI FERMO E FERMO PIN AND STOP PIN PLONT ET PLOT D'ARRET ANSCHLAGBOLZEN	UNI3740 8.8 UNI 3951 A2-70 ZINCATO - GALVANIZED - ZINGUE - VERZINKT ON REQUEST
14	DADO - CONTRODADO NUT - LOCK NUT ECROU - CONTRE-ECROU MUTTER - KONTERMUTTER	UNI 3740 - 6S ASTM A479 304 ZINCATO - GALVANIZED - ZINGUE - VERZINKT ON REQUEST
15	LEVA WRENCH LEVIER HANDHEBEL	AISI 1010 ASTM A479 304 ZINCATO/VERNICIATO GALVANIZED/PAINTED ZINGUE/PEINT VERZINKT/GEMALTEN ON REQUEST
16	VITE SCREW VIS SCHRAUBE	UNI 3740 8.8 UNI 3951 A2-70 ZINCATO - GALVANIZED - ZINGUE - VERZINKT ON REQUEST

* RICAMBI CONSIGLIATI - RECOMMENDED SPARE PARTS - PIECES DE RECHANGE CONSEILLEES - ERSATZTEIL EMPFEHLUNG

DIMENSIONI - DIMENSION - DIMENSIONS - ABMESSUNGEN

DN	15	20	25	32	40	50	65	80	100	125	150	200	250	300
A	10	10	12	12	16	16	22	22	30	30	42	48	56	56
B	6	6	8	8	10	10	14	14	18	18	28	32	36	36
C	7	7	10	10	10	10	12	12	16,5	16,5	19	20	20	20
D	49	51,5	50	51,5	59	61,5	70,5	73	85	100	144	180,5	196	237
D											117	155		
E	15	19	25	30	38	51	64	76	101	118	152	203	254	305
F	M5	M5	M5	M5	M6	M6	M8	M8	M8	M10	M12	M16	M20	M20
ISO	F03	F03	F03	F03	F05	F05	F07	F07	F07	F10	F12	F14	F16	F16
G	25	25	25	25	35	35	55	55	55	70	85	100	130	130
H	86	88	113	119	110	120	144	152	174	188	256	294	343	381
L	35	35	35	35	46,5	46,5	64,5	64,5	72	93	111	130	153	153
M	145	145	185	185	280	280	370	370	470	650	750	900	1000	1000
N	58	58	58	58	72,5	72,5	90	90	70	97	108	126	153	153
P	33,7	36	49,3	54,8	64,8	74,8	93,5	102	99,5	119	144	183	220	258,5
R	7	7	9	9	10	10	11	11	26	26	34	37	45	45
S	115	120	125	130	140	150	170	180	190	325	350	400	450	500
T	36	36	36	36	50	50	70	70	70	102	125	140	165	165
Kg	3	4	5,2	7	10	13,5	21,5	26	30,5	61	96	157	215	255
Kg										50	70	120	175	200

ASTM A105

ASTM A 351 CF8M

- DATI E CARATTERISTICHE SOGGETTI A VARIAZIONI SENZA PRAEAVVISO
- SPECIFICATIONS SUBJECT TO MODIFICATIONS WITHOUT PRIOR NOTICE
- TOUS DROITS DE MODIFICATION RESERVES
- KONSTRUKTIONSAENDERUNGEN VORBEHALTEN



ADLER SpA - BALL VALVES
 20010 S. STEFANO TICINO (MI) ITALY V.le BORLETTI, 14 Tel. +39/02974842.11 FAX +39/0297271698
 E-mail: adler@adlerspa.com <http://www.adlerspa.com>

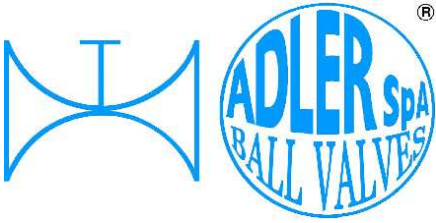

ISO 9001:2015 by L.R.
 PED DIR. 2014/68/UE by L.R.
 ATEX DIR. 2014/34/UE by B.V.
 FIRE SAFE EXECUTION by L.R.
 ISO 15848 by TÜV
 ANTISTATIC DEVICE by L.R.
 FIRE SAFE TESTED ISO 10497 by L.R.
 EAC CERTIFICATION by B.V.

TYPE
FM2
 PN 10 ÷ 40

• ESECUZIONI • EXECUTIONS • EXECUTIONS • AUSFÜHRUNGEN



EXECUTION 4- 12

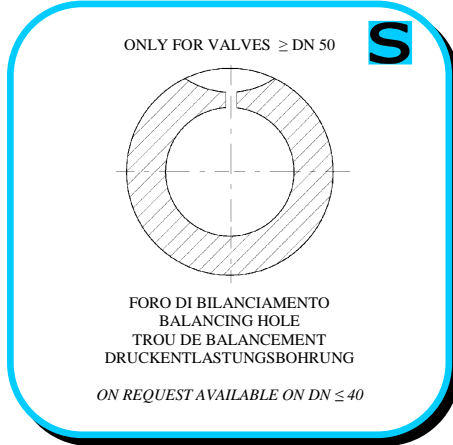

EXECUTION 6 - 16

S STANDARD

O OPTIONAL

1 **S**

CARBON STEEL

ASTM A105
DN 15 ÷ 300

2 **S**

DN 15 ÷ 80

3 **S**

STAINLESS STEEL
ASTM A479 316/316L
DN 15 ÷ 125

ASTM A351 CF8M
DN 150 ÷ 300

4 **S**

-STELO ANTI ESPULSIONE -ANTI BLOW OUT STEM
 -TIGE ANTIEXPULSION -AUSBLASGESICHERTE WELLE

-PACCO A "V" -CHEVRON RINGS
 -JOINT A "V" -3 FACHE DACHMANSCHETE
 ANTISTATIC DEVICE ANTISTATIK VORRICHTUNG
 BS 5146

5 **S**

DN 15 ÷ 80

SCREW
 UNI 3740-10.9
 (GALVANIZED)

"ISO" PLATE
 ASTM A351 CF8M
 (PICKLED)

6 **O**

BREVETTO - PATENTED
00219688 - 21-04-1993

FKM (VITON)

-"O" RING STELO "O" RING ON STEM
 -TIGE AVEC "O" RING
 -"O" RING IM SPINDELBEREICH



ISO 9001:2015 by L.R.
 PED DIR. 2014/68/UE by L.R.
 ATEX DIR. 2014/34/UE by B.V.
 FIRE SAFE EXECUTION by L.R.
 ISO 15848 by TÜV
 ANTISTATIC DEVICE by L.R.
 FIRE SAFE TESTED ISO 10497 by L.R.
 EAC CERTIFICATION by B.V.

TYPE
FM2
 PN 10 ÷ 40

7

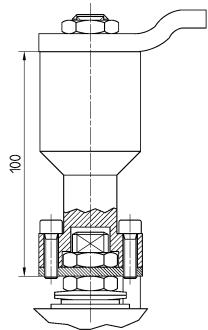

-PROLUNGA STELO -STEM EXTENSION
 -TIGE PROLONGEE -SPINDELVERLÄNGERUNG

8

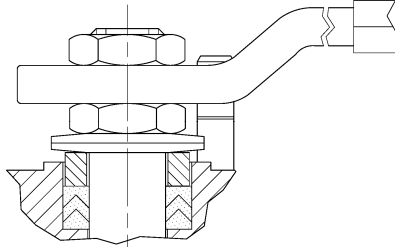

-PARTICOLARI INOX
 -STAINLESS STEEL DETAILS
 -ACCESSOIRES EN INOX
 -EDELSTAHLTEILE

9

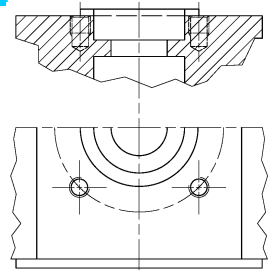

-ATTACCO "ISO" -"ISO" CONNECTIONS
 -SYSTEM "ISO" -ANSCHLUSS "ISO"

**GEAR BOX
 AG series**



11

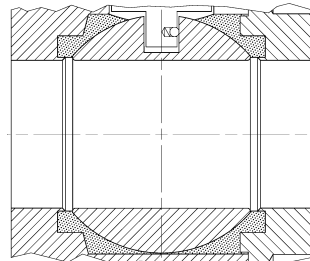

-TENUTE INTEGRALE -POCKETLESS SEATS
 -TENUE INTEGRALE -TOTRAUMARM
 -P.T.F.E. / R.T.F.E.

12

**FIRE SAFE
 ISO 10497 "ISO-FT"
 (BS 6755 / API 607)**



13

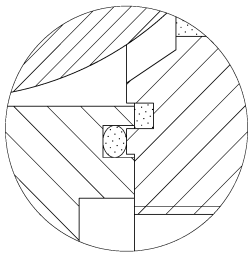

**BREVETTO - PATENTED
 00219619**
 -DOPPIA TENUTA -DOUBLE SEALS
 -DOUBLE ETANCHEITE -DOPPELTE ABDICHTUNG
 -LATERALE A BATTUTA -METAL BEATING END
 -LATERAL AVEC BATTUE MECANIQUE
 -METALLISCHER ANSCHLAG DES
 GEGENGEHÄUSES

14

VEDERE / SEE ANSI B16.34

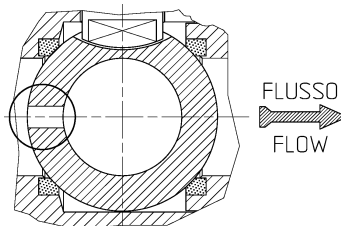

FLUSSO
 FLOW

-FORO DI SCARICO NELLA SFERA
 -OVERPRESSURE HOLE INTO BALL
 -TROU DECOMPRESSION DANS LA BOULE
 -ENTLASTUNGSBOHRUNG IN DER KUGEL
**VALVOLA MONO DIREZIONALE
 MONO-DIRECTIONAL VALVE**

15

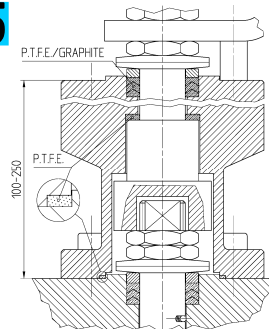

-SERVIZIO CRIOGENICO - CRYOGENIC SERVICE
 -SERVICE CRYOGENIQUE
 -TIEFTEMPERATUR SERVICE

16



-FIRE SAFE ISO FT+ "O" RING STELO
 -FIRE SAFE ISO FT+ "O" RING ON STEM
 -SECURITE FEU ISO FT+ TIGE AVEC "O" RING
 -FEUERSICHERE AUSFÜHRUNG ISO FT+
 "O" RING IM SPINDELBEREICH

17

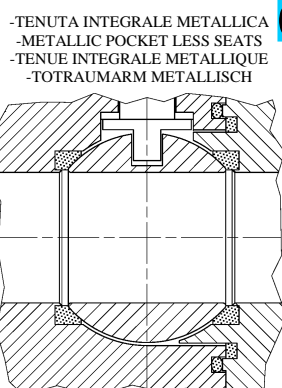

-TENUTA INTEGRALE METALLICA
 -METALLIC POCKET LESS SEATS
 -TENUE INTEGRALE METALLIQUE
 -TOTRAUMARM METALLISCH

18

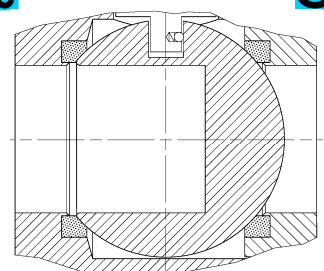

-SFERA CIECA PER CAMPIONATURA
 -BLIND BALL FOR SAMPLING
 -PRISE-ECHANTILLON
 KUGEL FÜR PROBENAHME

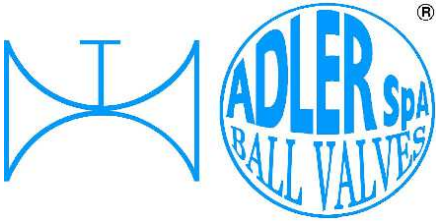

ISO 9001:2015 by L.R.
 PED DIR. 2014/68/UE by L.R.
 ATEX DIR. 2014/34/UE by B.V.
 FIRE SAFE EXECUTION by L.R.
 ISO 15848 by TÜV
 ANTISTATIC DEVICE by L.R.
 FIRE SAFE TESTED ISO 10497 by L.R.
 EAC CERTIFICATION by B.V.

TYPE
FM2
 PN 10 ÷ 40

DIMENSIONI FLANGE - FLANGE DIMENSION - DIMENSIONS BRIDES - FLANSCHANSCHLUSSMASSE

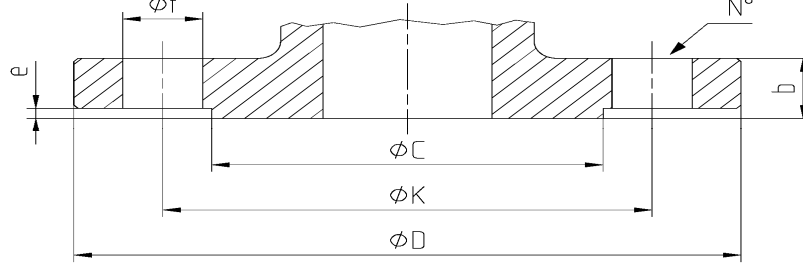

DN	Ref.	10	15	20	25	32	40	50	65	80	100	125	150	200	250	300	
PN 10	D		95	105	115	140	150	165	185	200	220	250	285	340	395	445	
	C		45	58	68	78	88	102	122	138	158	188	212	268	320	370	
	K		65	75	85	100	110	125	145	160	180	210	240	295	350	400	
	N°		4	4	4	4	4	4	4	4*	8	8	8	8	8	12	12
	f		14	14	14	18	18	18	18	18	18	18	18	22	22	22	22
	b		16	18	18	18	18	18	18	18	20	20	22	22	24	26	26
	e		2	2	2	2	3	3	3	3	3	3	3	3	3	3	4
PN 16	D		95	105	115	140	150	165	185	200	220	250	285	340	405	460	
	C		45	58	68	78	88	102	122	138	158	188	212	268	320	378	
	K		65	75	85	100	110	125	145	160	180	210	240	295	355	410	
	N°		4	4	4	4	4	4	4	4*	8	8	8	8	12	12	12
	F		14	14	14	18	18	18	18	18	18	18	22	22	26	26	
	b		16	18	18	18	18	18	18	18	20	20	22	22	24	26	28
	e		2	2	2	2	3	3	3	3	3	3	3	3	3	3	4
PN 25	D		95	105	115	140	150	165	185	200	235	270	300	360	425	485	
	C		45	58	68	78	88	102	122	138	162	188	218	278	335	395	
	K		65	75	85	100	110	125	145	160	190	220	250	310	370	430	
	N°		4	4	4	4	4	4	4	8	8	8	8	12	12	16	
	f		14	14	14	18	18	18	18	18	22	26	26	26	30	30	
	b		16	18	18	18	18	20	22	24	24	26	28	30	32	34	
	e		2	2	2	2	3	3	3	3	3	3	3	3	3	4	
PN 40	D		95	105	115	140	150	165	185	200	235	270	300	375	450	515	
	C		45	58	68	78	88	102	122	138	162	188	218	285	345	410	
	K		65	75	85	100	110	125	145	160	190	220	250	320	385	450	
	N°		4	4	4	4	4	4	4	8	8	8	8	12	12	16	
	f		14	14	14	18	18	18	18	18	22	26	26	30	33	33	
	b		16	18	18	18	18	20	22	24	24	26	28	34	38	42	
	e		2	2	2	2	3	3	3	3	3	3	3	3	3	4	

ADLER SALES DEPT.

