

ISO 9001:2015 by L.R.
PED DIR. 2014/68/UE by L.R.
ATEX DIR. 2014/34/UE by B.V.
FIRE SAFE EXECUTION by L.R.
ISO 15848 by TÜV (UP TO PN 63)
ANTISTATIC DEVICE by L.R.
FIRE SAFE TESTED ISO 10497 by L.R.
EAC CERTIFICATION by B.V.

TYPE
FN2
PN 10 ÷ 40 ÷ 63 ÷ 100

NORME E DIRETTIVE APPLICATE DISPONIBILI AL SEGUENTE LINK:
STANDARD AND DIRECTIVE APPLIED AVAILABLE AT FOLLOWING LINK:
http://www.adlerspa.com/pdf/NORME_ADLER.pdf

VALVOLE A SFERA "UNI EN 558-1" SPLIT BODY PASSAGGIO TOTALE

ISO nbr° LRC 0160281 QMS issued by L.R.Q.A. PED nbr° COV 0212112/01 issued by L.R.V.
ATEX nbr° 40.2003.4392 issued by B.V. ISO 15848 nbr° I-148466/1-/2 issued by TÜV



FULL BORE ACCORDING
TO ISO 14313

On request
S.I.L. 3
According to IEC 61508

On request
FIRE SAFE
According to ISO 10497
"ISO-FT"

CONSTRUCTION ACCORDING TO:
BS EN 12516-2 - ISO 14313
UNI EN 558-1

BALL VALVES
"UNI EN 558-1" FULL BORE SPLIT BODY
ROBINETS A BOISSEAU SPHERIQUE
"UNI EN 558-1" PASSAGE INTEGRAL 2 PIECES
FLANSCHKUGELHÄHNE IN "UNI EN 558-1"
VOLLER DURCHGANG ZWEIFTEILIGES GEHÄUSE

WEB SITE: WWW.ADLERSPA.COM

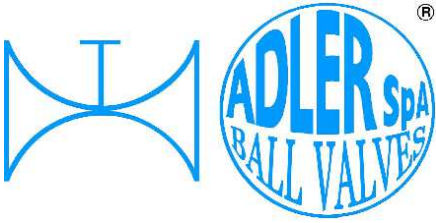

ISO 9001:2015 by L.R.
 PED DIR. 2014/68/UE by L.R.
 ATEX DIR. 2014/34/UE by B.V.
 FIRE SAFE EXECUTION by L.R.
 ISO 15848 by TÜV (UP TO PN 63)
 ANTISTATIC DEVICE by L.R.
 FIRE SAFE TESTED ISO 10497 by L.R.
 EAC CERTIFICATION by B.V.

TYPE
FN2
 PN 10 ÷ 40 ÷ 63 ÷ 100

VALVOLA A SFERA "UNI EN 558-1" SPLIT BODY PASSAGGIO TOTALE
BALL VALVES "UNI EN 558-1" SPLIT BODY FULL BORE
ROBINETS A BOISSEAU SPHERIQUE "UNI EN 558-1" PASSAGE INTEGRAL 2 PIECES
FLANSCHKUGELHÄHNE IN "UNI EN 558-1" VOLLER DURCHGANG ZWEITEILIGES GEHÄUSE

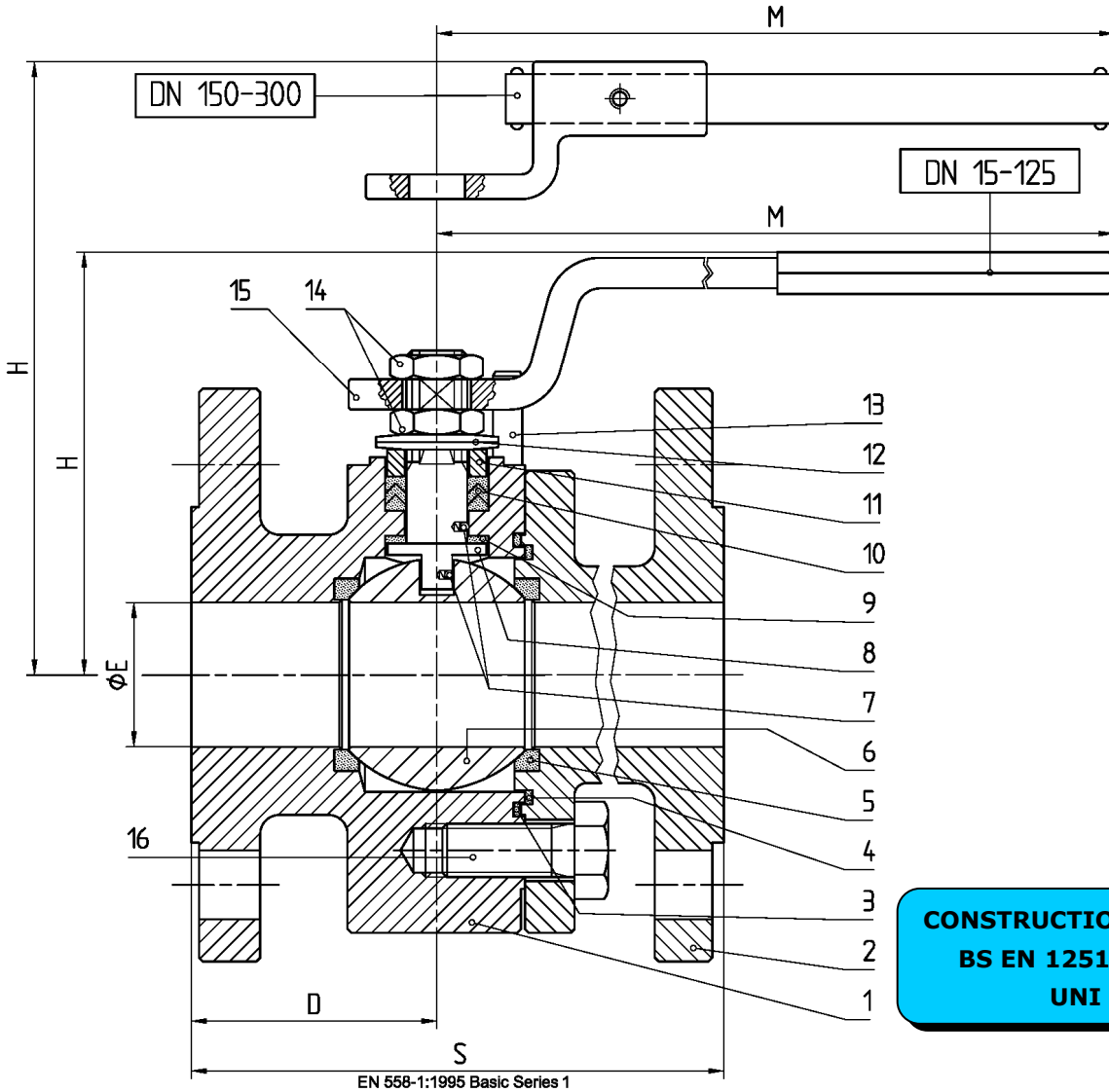

DN 200 ÷ 300
 -CONSIGLIATO
 RIDUTTORE MANUALE
 -MANUAL GEAR BOX
 SUGGESTED
 -REDUCTEUR MANUEL
 CONSEILLE
 -EMPFEHLEN WIR EIN
 HANDGETRIEBE

CONSTRUCTION ACCORDING TO:
BS EN 12516-2 - ISO 14313
UNI EN 558-1

ADLER BALL VALVES FN2/19 RIPRODUZIONE VIETATA - COPYRIGHT

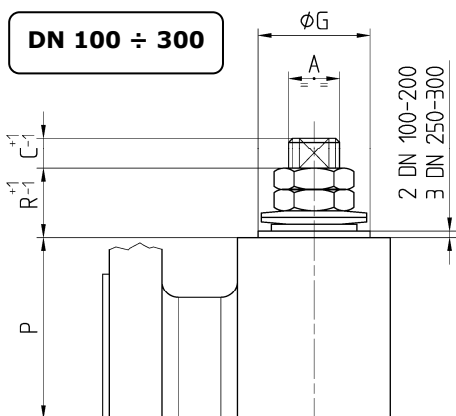

• ACCOPPIAMENTO VALVOLA
 ATTUATORE
 • CONNECTION VALVE
 ACTUATOR
 • ACCOUPLEMENT ROBINET-
 ACTIONNEUR
 • ZUSAMMENBAU KUGELHAHN
 ANTRIEB
ISO-5211

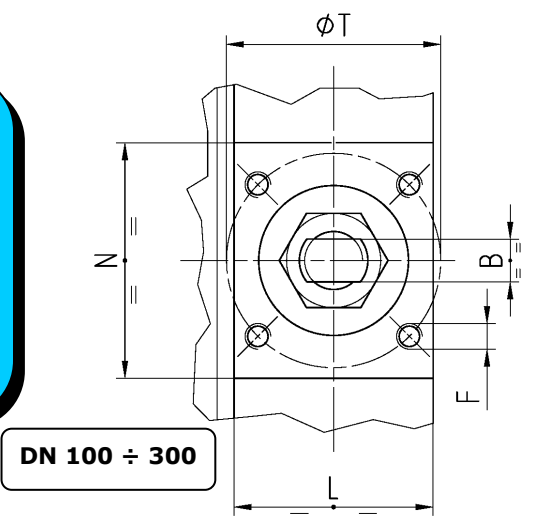

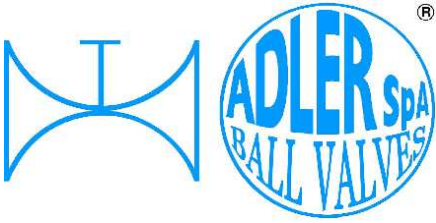

ISO 9001:2015 by L.R.
 PED DIR. 2014/68/UE by L.R.
 ATEX DIR. 2014/34/UE by B.V.
 FIRE SAFE EXECUTION by L.R.
 ISO 15848 by TÜV (UP TO PN 63)
 ANTISTATIC DEVICE by L.R.
 FIRE SAFE TESTED ISO 10497 by L.R.
 EAC CERTIFICATION by B.V.

TYPE
FN2
 PN 10 ÷ 40 ÷ 63 ÷ 100

N.	DESCRIZIONE DESCRIPTION DESCRIPTION BESCHREIBUNG	MATERIALI MATERIALS MATERIAUX WERKSTOFFE
1	CORPO BODY CORPS MITTE	ASTM A105 ASTM A479 304/304L ASTM A479 316/316L ASTM A 351 CF8M
2	LATERALE END LATERAL ENDE	ASTM A105 ASTM A479 304/304L ASTM A479 316/316L ASTM A 351 CF8M
3*	O-RING	FKM - (VITON)
4*	ANELLO SEAL ANNEAU DICHTUNGSRING	P.T.F.E.
5*	SEDE SEAT SIEGE SITZRING	P.T.F.E. (BAM CERTIFIED) R.P.T.F.E. (OPTIONAL)
6	SFERA BALL BOULE KUGEL	ASTM A479 304/304L ASTM A351 CF8 ASTM A479 316/316L ASTM A351 CF8M
7	DISPOSITIVO ANTISTATICO ANTISTATIC DEVICE CONTACT ANTISTATIQUE ANTISTATIK VORRICHTUNG	ASTM A479 316/316L
8	STELO STEM TIGE SPINDEL	ASTM A479 304/304L ASTM A479 316/316L

N.	DESCRIZIONE DESCRIPTION DESCRIPTION BESCHREIBUNG	MATERIALI MATERIALS MATERIAUX WERKSTOFFE
9*	BUSSOLA STEM SEAL JOINT TIGE UNTERE SPINDELABDICHTUNG	P.T.F.E.
10*	PACCO A "V" CHEVRON RINGS JOINT A "V" 3 FACHE DACHMANSCHETTE	P.T.F.E. / GRAFITE P.T.F.E. / GRAPHITE P.T.F.E. / GRAPHITE P.T.F.E. / GRAPHIT
11	PREMIBUSSOLA PRESSING BUSH PRESSE RONDELLE STOPFBUCHSDRUCKRING	ASTM A479 304
12	MOLLE A TAZZA SPRING WASHERS RONDELLES BELLEVILLE TELLERFEDERN	C72/50Cr V4 X5CrNi17.7 or X12CrNi17.7 ZINCATO - GALVANIZED - ZINGUE - VERZINKT ON REQUEST
13	VITE DI FERMO E FERMO PIN AND STOP PIN PLONT ET PLOT D'ARRET ANSCHLAGBOLZEN	UNI3740 8.8 UNI 3951 A2-70 ZINCATO - GALVANIZED - ZINGUE - VERZINKT ON REQUEST
14	DADO - CONTRODADO NUT - LOCK NUT ECROU - CONTRE-ECROU MUTTER - KONTERMUTTER	UNI 3740 - 6S ASTM A479 304 ZINCATO - GALVANIZED - ZINGUE - VERZINKT ON REQUEST
15	LEVA WRENCH LEVIER HANDHEBEL	AISI 1010 ASTM A479 304 ZINCATO/VERNICIATO GALVANIZED/PAINTED ZINGUE/PEINT VERZINKT/GEMALTEN ON REQUEST
16	VITE SCREW VIS SCHRAUBE	UNI 3740 8.8 UNI 3951 A2-70 ZINCATO - GALVANIZED - ZINGUE - VERZINKT ON REQUEST

* RICAMBI CONSIGLIATI - RECOMMENDED SPARE PARTS - PIECES DE RECHANGE CONSEILLEES - ERSATZTEIL EMPFEHLUNG

DIMENSIONI - DIMENSION - DIMENSIONS - ABMESSUNGEN

DN	15	20	25	32	40	50	65	80	100	125	150	200	250	300
A	10	10	12	12	16	16	22	22	30	30	42	48	56	56
B	6	6	8	8	10	10	14	14	18	18	28	32	36	36
C	7	7	10	10	10	10	12	12	16,5	16,5	19	20	20	20
D	49	51,5	50	51,5	59	61,5	70,5	73	85	100	144	180,5	196	237
											117	155		
E	15	19	25	30	38	51	64	76	101	118	152	203	254	305
F	M5	M5	M5	M5	M6	M6	M8	M8	M8	M10	M12	M16	M20	M20
ISO	F03	F03	F03	F03	F05	F05	F07	F07	F07	F10	F12	F14	F16	F16
G	25	25	25	25	35	35	55	55	55	70	85	100	130	130
H	86	88	113	119	110	120	144	152	174	188	256	294	/	/
L	35	35	35	35	46,5	46,5	64,5	64,5	72	93	111	130	153	153
M	145	145	185	185	280	280	370	370	470	650	750	900	/	/
N	58	58	58	58	72,5	72,5	90	90	70	97	108	126	153	153
P	33,7	36	49,3	54,8	64,8	74,8	93,5	102	99,5	119	144	183	220	258,5
R	7	7	9	9	10	10	11	11	26	26	34	37	45	45
S	130	150	160	180	200	230	290	310	350	400	480	600	730	850
T	36	36	36	36	50	50	70	70	70	102	125	140	165	165
Kg	3,1	4,1	5,4	7,3	10,7	15,5	25,3	31,4	41	67	104	175	247	300
Kg										52	75	133	197	230

ASTM A105

ASTM A 351 CF8M

PN 10 ÷ 40

- DATI E CARATTERISTICHE SOGGETTI A VARIAZIONI SENZA PREAVVISO
- SPECIFICATIONS SUBJECT TO MODIFICATIONS WITHOUT PRIOR NOTICE
- TOUS DROITS DE MODIFICATION RESERVES
- KONSTRUKTIONÄNDERUNGEN VORBEHALTEN



ADLER SpA - BALL VALVES
 20010 S. STEFANO TICINO (MI) ITALY V.le BORLETTI, 14 Tel. +39/02974842.11 FAX +39/0297271698
 E-mail: adler@adlerspa.com <http://www.adlerspa.com>

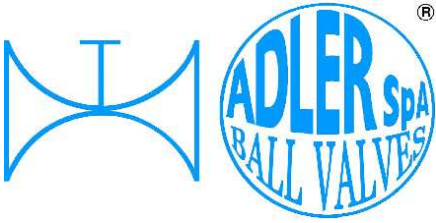

ISO 9001:2015 by L.R.
 PED DIR. 2014/68/UE by L.R.
 ATEX DIR. 2014/34/UE by B.V.
 FIRE SAFE EXECUTION by L.R.
 ISO 15848 by TÜV (UP TO PN 63)
 ANTISTATIC DEVICE by L.R.
 FIRE SAFE TESTED ISO 10497 by L.R.
 EAC CERTIFICATION by B.V.

TYPE
FN2
 PN 10 ÷ 40 ÷ 63 ÷ 100

VALVOLA A SFERA "UNI EN 558-1" SPLIT BODY PASSAGGIO TOTALE
BALL VALVES "UNI EN 558-1" SPLIT BODY FULL BORE
ROBINETS A BOISSEAU SPHERIQUE "UNI EN 558-1" PASSAGE INTEGRAL 2 PIECES
FLANSCHKUGELHÄHNE IN "UNI EN 558-1" VOLLER DURCHGANG ZWEITEILIGES GEHÄUSE

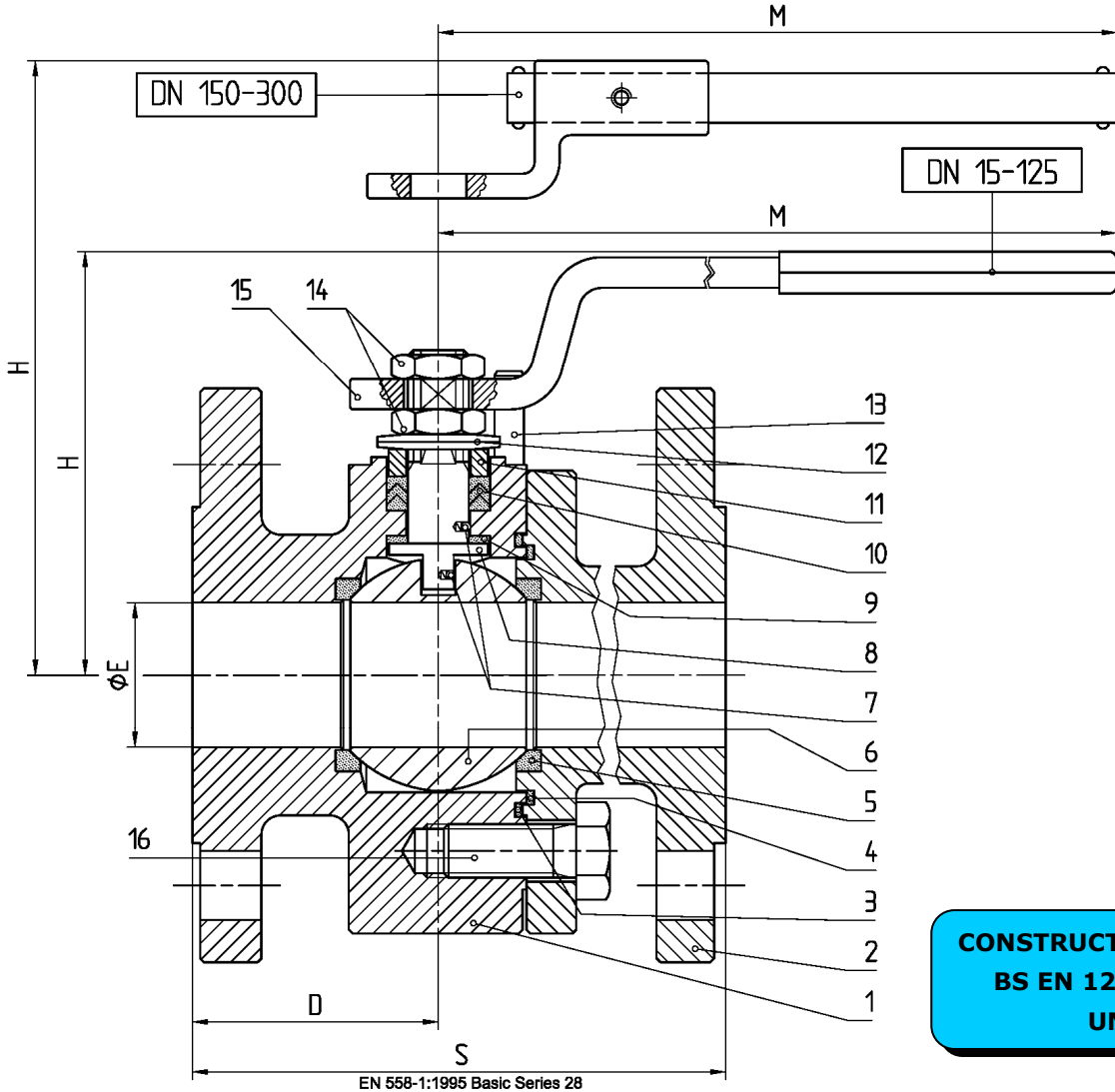

DN 200 ÷ 300
 -CONSIGLIATO
 RIDUTTORE MANUALE
 -MANUAL GEAR BOX
 SUGGESTED
 -REDUCTEUR MANUEL
 CONSEILLE
 -EMPFEHLEN WIR EIN
 HANDGETRIEBE

CONSTRUCTION ACCORDING TO:
BS EN 12516-2 - ISO 14313
UNI EN 558-1

ADLER BALL VALVES FN2/19 RIPRODUZIONE VIETATA - COPYRIGHT

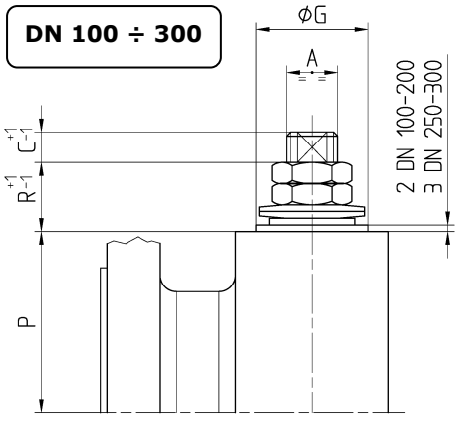

• ACCOPPIAMENTO VALVOLA
 ATTUATORE
 • CONNECTION VALVE
 ACTUATOR
 • ACCOUPLEMENT ROBINET-
 ACTIONNEUR
 • ZUSAMMENBAU KUGELHAHN
 ANTRIEB

ISO-5211

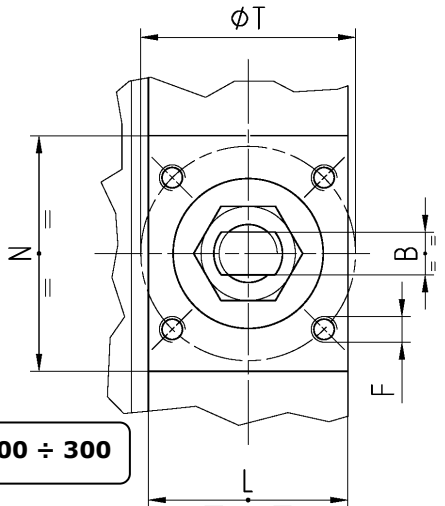

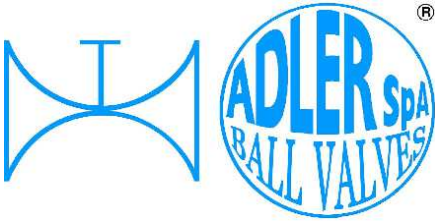

ISO 9001:2015 by L.R.
 PED DIR. 2014/68/UE by L.R.
 ATEX DIR. 2014/34/UE by B.V.
 FIRE SAFE EXECUTION by L.R.
 ISO 15848 by TÜV (UP TO PN 63)
 ANTISTATIC DEVICE by L.R.
 FIRE SAFE TESTED ISO 10497 by L.R.
 EAC CERTIFICATION by B.V.

TYPE
FN2
 PN 10 ÷ 40 ÷ 63 ÷ 100

N.	DESCRIZIONE DESCRIPTION DESCRIPTION BESCHREIBUNG	MATERIALI MATERIALS MATERIAUX WERKSTOFFE
1	CORPO BODY CORPS KÖRPER	ASTM A105 ASTM A479 316/316L
2	LATERALE END LATERAL GEGENGEHÄUSE	ASTM A105 ASTM A479 316/316L
3*	O-RING	FKM - (VITON)
4*	ANELLO SEAL ANNEAU DICHTUNGSRING	P.T.F.E.
5*	SEDE RINFORZATA SEAT REINFORCED SIEGE RENFORCE SITZRING VERSTÄRKT	P.T.F.E. /STAINLESS STEEL
6	SFERA BALL BOULE KUGEL	ASTM A479 304/304L ASTM A351 CF8 ASTM A479 316/316L ASTM A351 CF8M
7	DISPOSITIVO ANTISTATICO ANTISTATIC DEVICE CONTACT ANTISTATIQUE ANTISTATIK VORRICHTUNG	ASTM A479 S31600
8	STELO STEM TIGE SPINDEL	ASTM A479 304/304L ASTM A479 316/316L

N.	DESCRIZIONE DESCRIPTION DESCRIPTION BESCHREIBUNG	MATERIALI MATERIALS MATERIAUX WERKSTOFFE
9*	BUSSOLA STEM SEAL JOINT TIGE UNTERE SPINDELABDICHTUNG	P.T.F.E.
10*	PACCO A "V" CHEVRON RINGS JOINT A "V" 3 FACHE DACHMANSCHETTE	P.T.F.E. / GRAFITE P.T.F.E. / GRAPHITE P.T.F.E. / GRAPHITE P.T.F.E. / GRAPHIT
11	PREMIBUSSOLA PRESSING BUSH PRESSE RONDELLE STOPFBUCHSDRUCKRING	ASTM A479 304
12	MOLLE A TAZZA SPRING WASHERS RONDELLES BELLEVILLE TELLERFEDERN	C72/50Cr V ₄ X5CrNi17.7 or X12CrNi17.7 ZINCATO - GALVANIZED - ZINGUE - VERZINKT ON REQUEST
13	VITE DI FERMO E FERMO PIN AND STOP PIN PLOT ET PLOT D'ARRET ANSCHLAGBOLZEN	UNI 3740 8.8 UNI 3951 A2-70 ZINCATO - GALVANIZED - ZINGUE - VERZINKT ON REQUEST
14	DADO - CONTRODADO NUT - LOCK NUT ECROU - CONTRE-ECROU MUTTER - KONTERMUTTER	UNI 3740 - 6S ASTM A479 304 ZINCATO - GALVANIZED ZINGUE - VERZINKT ON REQUEST
15	LEVA WRENCH LEVIER HANDHEBEL	AISI 1010 ASTM A479 304 ZINCATO/VERNICIATO GALVANIZED/PAINTED ZINGUE/PEINT VERZINKT/GERMALTEN ON REQUEST
16	VITE SCREW VIS SCHRAUBE	UNI 3740 8.8 UNI 3951 A2-70 ZINCATO - GALVANIZED - ZINGUE - VERZINKT ON REQUEST

* RICAMBI CONSIGLIATI - RECOMMENDED SPARE PARTS - PIECES DE RECHANGE CONSEILLEES - ERSATZTEIL EMPFEHLUNG

DIMENSIONI - DIMENSION - DIMENSIONS - ABMESSUNGEN

DN	15	20	25	40	50	50	65	65	80	80	100	150
PN	100	63÷160	63÷160	63÷100	63	100÷160	63	100	63	100÷160	63	63
AxB	12x8	12x8	16x10	22x14	22x14	22x14	30x18	30x18	30x18	30x18	42x28	48x32
C	7	7	8	16	16	12	17	17	17	17	19	19
D	52	61	61,5	81	88,5	90,5	122	122	115	115	140	174
E	15	19	25	38	51	51	64	64	76	76	101	152
F	M5	M5	M6	M8	M8	M8	M8	M8	M8	M8	M12	M16
ISO	F03	F03	F05	F07	F07	F07	F07	F07	F07	F07	F12	F14
G	25	25	35,5	55	55	55	55	55	55	55	85	100
H	105	110	100	125	135	140	161	161	170	170	190	
L	33	33	46,5	62	65	63	80	80	84	81	125	140
M	185	185	280	370	370	370	470	470	470	470	650	
N	43	65	72,5	70	79	85	82	82	80	93	109	135
P	35,5	43	55,9	66,5	76,5	76,5	94	101	97	97	111,5	163
R	14	9	10	19	19	25	20	13	26	26	34	27
S	130	150	160	200	230	230	290	290	310	310	350	480
T	36	36	50	70	70	70	70	70	70	70	125	140
~ Kg	4	5,2	6,5	15	21	21	30	30	37	37	50	110

- DATI E CARATTERISTICHE SOGGETTI A VARIAZIONI SENZA PREAVVISO
- SPECIFICATIONS SUBJECT TO MODIFICATIONS WITHOUT PRIOR NOTICE
- TOUS DROITS DE MODIFICATION RESERVES
- KONSTRUKTIONSÄNDERUNGEN VORBEHALTEN

PN 63 ÷ 160



ADLER SpA - BALL VALVES
 20010 S. STEFANO TICINO (MI) ITALY V.le BORLETTI, 14 Tel. +39/02974842.11 FAX +39/0297271698
 E-mail: adler@adlerspa.com <http://www.adlerspa.com>

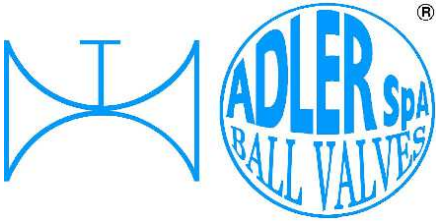

ISO 9001:2015 by L.R.
 PED DIR. 2014/68/UE by L.R.
 ATEX DIR. 2014/34/UE by B.V.
 FIRE SAFE EXECUTION by L.R.
 ISO 15848 by TÜV (UP TO PN 63)
 ANTISTATIC DEVICE by L.R.
 FIRE SAFE TESTED ISO 10497 by L.R.
 EAC CERTIFICATION by B.V.

TYPE
FN2
 PN 10 ÷ 40 ÷ 63 ÷ 100

• ESECUZIONI • EXECUTIONS • EXECUTIONS • AUSFÜHRUNGEN



EXECUTION 4- 12

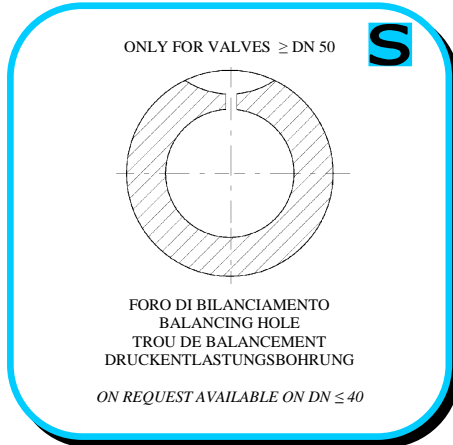

EXECUTION 6 - 16

S STANDARD

O OPTIONAL

1 **S**

CARBON STEEL

ASTM A105
 DN 15 ÷ 300

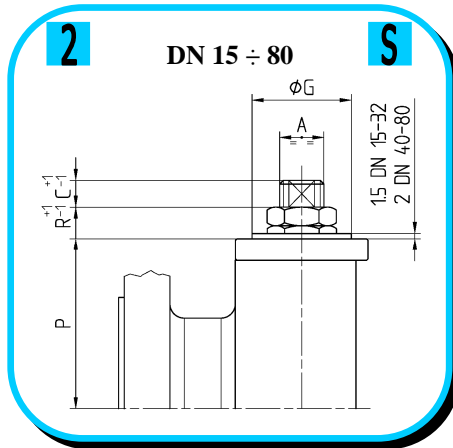

3 **S**

STAINLESS STEEL
 ASTM A479 316/316L
 DN 15 ÷ 125

ASTM A351 CF8M
 DN 150 ÷ 300

4 **S**

-STELO ANTI ESPULSIONE -ANTI BLOW OUT STEM
 -TIGE ANTIEXPULSION -AUSBLASGESICHERTE WELLE

-PACCO A "V" -CHEVRON RINGS
 -JOINT A "V" -3 FACHE DACHMANSCHETE
 ANTISTATIC DEVICE ANTISTATIK VORRICHTUNG
 BS 5146

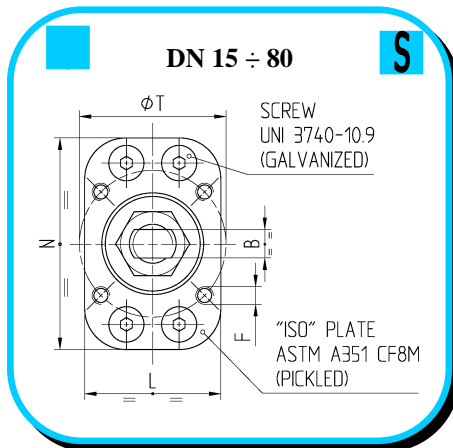

6 **O**

BREVETTO - PATENTED
 00219688 - 21-04-1993

FKM (VITON)

-"O" RING STELO "O" RING ON STEM
 -TIGE AVEC "O" RING
 -"O" RING IM SPINDELBEREICH

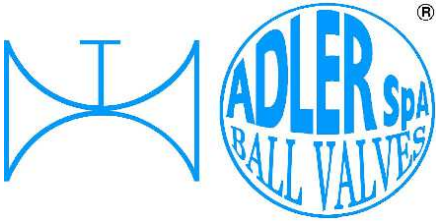

ISO 9001:2015 by L.R.
 PED DIR. 2014/68/UE by L.R.
 ATEX DIR. 2014/34/UE by B.V.
 FIRE SAFE EXECUTION by L.R.
 ISO 15848 by TÜV (UP TO PN 63)
 ANTISTATIC DEVICE by L.R.
 FIRE SAFE TESTED ISO 10497 by L.R.
 EAC CERTIFICATION by B.V.

TYPE
FN2
 PN 10 ÷ 40 ÷ 63 ÷ 100

7 **O**

-PROLUNGA STELO -STEM EXTENSION
 -TIGE PROLONGEE -SPINDELVERLÄNGERUNG

8 **O**

-PARTICOLARI INOX
 -STAINLESS STEEL DETAILS
 -ACCESSOIRES EN INOX
 -EDELSTAHLTEILE

9 **S**

-ATTACCO "ISO" -"ISO" CONNECTIONS
 -SYSTEM "ISO" -ANSCHLUSS "ISO"

TESTING

11 **O**

-TENUTE INTEGRALE -POCKETLESS SEATS
 -TENUE INTEGRALE -TOTRAUMARM
 -P.T.F.E. / R.T.F.E.

12 **O**

FIRE SAFE
 ISO 10497 "ISO-FT"
 (BS 6755 / API 607)

13 **S**

BREVETTO - PATENTED
 00219619

-DOPPIA TENUTA -DOUBLE SEALS
 -DOUBLE ETANCHEITE -DOPPELTE ABDICHTUNG
 -LATERALE A BATTUTA -METAL BEATING END
 -LATERAL AVEC BATTUE MECANIQUE
 -METALLISCHER ANSCHLAG DES
 GEGENGEHÄUSES

14 **O**

VEDERE / SEE ANSI B16.34

FLUSSO
 FLOW

-FORO DI SCARICO NELLA SFERA
 -OVERPRESSURE HOLE INTO BALL
 -TROU DECOMPRESSION DANS LA BOULE
 -ENTLASTUNGSBOHRUNG IN DER KUGEL
 VALVOLA MONO DIREZIONALE
 MONO-DIRECTIONAL VALVE

15 **O**

P.T.F.E./GRAPHITE
 P.T.F.E.
 100-250

-SERVIZIO CRIOGENICO - CRYOGENIC SERVICE
 -SERVICE CRYOGENIQUE
 -TIEFTEMPERATUR SERVICE

16 **O**

-FIRE SAFE ISO FT+ "O" RING STELO
 -FIRE SAFE ISO FT+ "O" RING ON STEM
 -SECURITE FEU ISO FT+ TIGE AVEC "O" RING
 -FEUERSICHERE AUSFÜHRUNG ISO FT+
 "O" RING IM SPINDELBEREICH

17 **O**

-TENUTA INTEGRALE METALLICA
 -METALLIC POCKET LESS SEATS
 -TENUE INTEGRALE METALLIQUE
 -TOTRAUMARM METALLISCH

**ALL VALVES
 CERTIFIED
 S.I.L. 3
 IN
 ACCORDING
 TO
 IEC 61508**

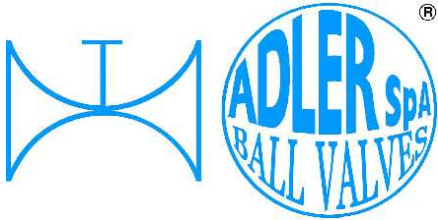

ISO 9001:2015 by L.R.
 PED DIR. 2014/68/UE by L.R.
 ATEX DIR. 2014/34/UE by B.V.
 FIRE SAFE EXECUTION by L.R.
 ISO 15848 by TÜV (UP TO PN 63)
 ANTISTATIC DEVICE by L.R.
 FIRE SAFE TESTED ISO 10497 by L.R.
 EAC CERTIFICATION by B.V.

TYPE
FN2
 PN 10 ÷ 40 ÷ 63 ÷ 100

DIMENSIONI FLANGE - FLANGE DIMENSION - DIMENSIONS BRIDES - FLANSCHANSCHLUSSMASSE

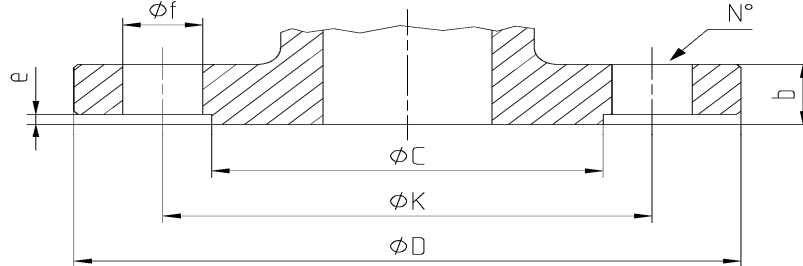

DN	Ref.	10	15	20	25	32	40	50	65	80	100	125	150	200	250	300	
PN 10	D	90	95	105	115	140	150	165	185	200	220	250	285	340	395	445	
	C	40	45	58	68	78	88	102	122	138	158	188	212	268	320	370	
	K	60	65	75	85	100	110	125	145	160	180	210	240	295	350	400	
	N°	4	4	4	4	4	4	4	4	4*	8	8	8	8	8	12	12
	f	14	14	14	14	14	18	18	18	18	18	18	18	22	22	22	22
	b	16	16	18	18	18	18	18	18	18	20	20	22	22	24	26	26
PN 16	e	2	2	2	2	2	3	3	3	3	3	3	3	3	3	4	
	D	90	95	105	115	140	150	165	185	200	220	250	285	340	405	460	
	C	40	45	58	68	78	88	102	122	138	158	188	212	268	320	378	
	K	60	65	75	85	100	110	125	145	160	180	210	240	295	355	410	
	N°	4	4	4	4	4	4	4	4	4*	8	8	8	8	12	12	12
	F	14	14	14	14	18	18	18	18	18	18	18	18	22	22	26	26
PN 25	b	16	16	18	18	18	18	18	18	20	20	22	22	24	26	28	
	e	2	2	2	2	2	3	3	3	3	3	3	3	3	3	4	
	D	90	95	105	115	140	150	165	185	200	235	270	300	360	425	485	
	C	40	45	58	68	78	88	102	122	138	162	188	218	278	335	395	
	K	60	65	75	85	100	110	125	145	160	190	220	250	310	370	430	
	N°	4	4	4	4	4	4	4	8	8	8	8	8	8	12	12	16
PN 40	f	14	14	14	14	18	18	18	18	18	22	26	26	26	30	30	
	b	16	16	18	18	18	18	20	22	24	24	26	28	30	32	34	
	e	2	2	2	2	2	3	3	3	3	3	3	3	3	3	4	
	D	90	95	105	115	140	150	165	185	200	235	270	300	375	450	515	
	C	40	45	58	68	78	88	102	122	138	162	188	218	285	345	410	
	K	60	65	75	85	100	110	125	145	160	190	220	250	320	385	450	
PN 63	N°	4	4	4	4	4	4	4	8	8	8	8	8	12	12	16	
	f	14	14	18	18	22	22	22	22	22	26	30	33	36	36	36	
	b	20	20	22	24	24	26	26	26	28	30	34	36	42	46	52	
	e	2	2	2	2	2	3	3	3	3	3	3	3	3	3	4	
	D	100	105	130	140	155	170	180	205	215	250	295	345	415	470	530	
	C	40	45	58	68	75	88	102	122	138	162	188	218	285	345	410	
PN 100	K	70	75	90	100	110	125	135	160	170	200	240	280	345	400	460	
	N°	4	4	4	4	4	4	4	8	8	8	8	8	12	12	16	
	f	14	14	18	18	22	22	22	26	26	30	33	33	36	39	42	
	b	20	20	22	24	24	26	28	30	32	36	40	44	52	60	68	
	e	2	2	2	2	2	3	3	3	3	3	3	3	3	3	4	
	D	100	105	130	140	155	170	195	220	230	265	315	355	430	505	585	
PN 160	C	40	45	58	68	75	88	102	122	138	162	188	218	285	345	410	
	K	70	75	90	100	110	125	145	170	180	210	250	290	360	430	500	
	N°	4	4	4	4	4	4	4	8	8	8	8	12	12	12	16	
	f	14	14	18	18	22	22	26	26	26	30	33	33	36	42	42	
	b	20	20	22	24	26	28	30	34	36	40	44	50	60	68	78	
	e	2	2	2	2	2	3	3	3	3	3	3	3	3	3	4	