

STRAINER

AL 87-10

Design

- Y-strainer
- Female threads BSP
- PN 40
- Temperature range -40°C - +180°
- Screen specification:
 - Hole diameter 1mm.
 - Distance between center of holes: 2mm

Kv value

Kv = Waterflow in m³/h at pressure drop 1 bar and temperature 20°C.

| DN | Kv |
|----|------|
| 8 | 1.7 |
| 10 | 3.2 |
| 15 | 5.4 |
| 20 | 11.9 |
| 25 | 23.0 |
| 32 | 36.6 |
| 40 | 54.4 |
| 50 | 98.6 |



Part / Material specification

| Pos | Part | Material | No of items |
|-----|----------------|----------|-------------|
| 1 | Body | CF8M | 1 |
| 2 | Screen | SUS 316 | 1 |
| 3 | Gasket packing | PTFE | 1 |
| 4 | Bonnet | CF8M | 1 |
| 5 | Plug gasket | PTFE | 1 |
| 6 | Blow of plug | CF8M | 1 |

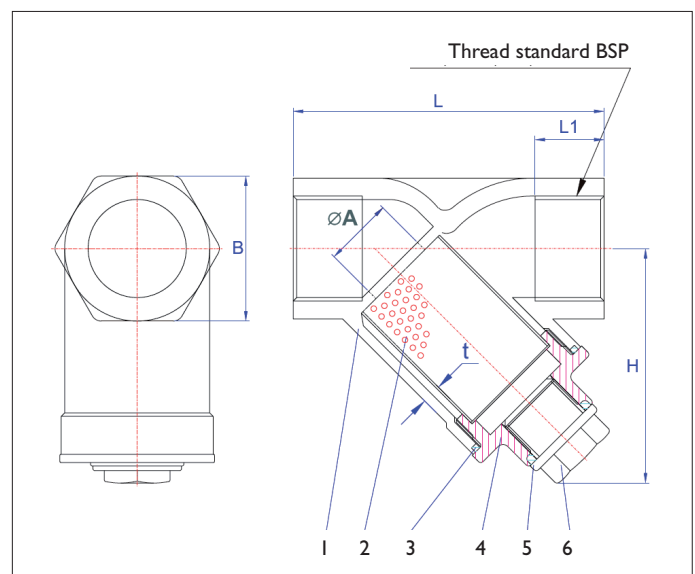

Dimensions

| Size | DN | B | A | H | L | L1 | t | Weight kg | Art.no |
|--------|----|------|----|----|-----|------|-----|-----------|---------|
| 1/4" | 8 | 23 | 11 | 46 | 65 | 13.5 | 3.0 | 0.24 | 3702150 |
| 3/8" | 10 | 23 | 13 | 46 | 65 | 14.0 | 3.0 | 0.23 | 3702152 |
| 1/2" | 15 | 26 | 15 | 46 | 65 | 15.0 | 3.0 | 0.23 | 3702154 |
| 3/4" | 20 | 32 | 20 | 55 | 80 | 17.0 | 3.0 | 0.36 | 3702156 |
| 1" | 25 | 41 | 25 | 70 | 90 | 19.0 | 3.5 | 0.70 | 3702158 |
| 1 1/4" | 32 | 50,5 | 32 | 73 | 105 | 20.0 | 3.6 | 0.90 | 3702160 |
| 1 1/2" | 40 | 57 | 38 | 81 | 120 | 22.0 | 4.0 | 1.20 | 3702162 |
| 2" | 50 | 69 | 50 | 94 | 140 | 23.5 | 4.3 | 1.90 | 3702164 |

AXEL LARSSON 

www.axel-larsson.se

Head Office Axel Larsson Maskinaffär AB, Truckvägen 12, P.O. Box 805, SE-194 28 Upplands Väsby (Stockholm), Sweden.
Telephone: +46 8 555 247 00 Fax: +46 8 555 247 90 E-mail: info@axel-larsson.se