

## 10.5 AI294

### 10.5.1 Technical Data



<b>Module ID</b>	<b>AI294</b>
<b>General Information</b>	
Model Number	7AI294.7
Short Description	2003 analog input module, 4 inputs, potentiometer evaluation, 13 bit, screw-in module
C-UL-US Listed	Yes
B&R ID Code	\$22
Slot	AF101 adapter module, CP interface
<b>Static Characteristics</b>	
Module Type	B&R 2003 screw-in module
Input Type	Single ended input in the range from 0 to $U_{pot}$
Number of Inputs	4
Affects of Cable Length	The shielded, twisted pair cable (3x1) should be as short as possible and run separately to the sensor (isolated from load circuit) without intermediate terminals
Shielding	
Module Side	Using stress relief clamp on the module
Potentiometer Side	Direct connection to grounded potentiometer housing (use short connection lines)
Maximum Continuous Overload (without damage)	+30 V for all connections except GND
Output of the Digital Value during Overload	
Open Connection on $U_{pot}$	Value = \$8000
Open Connection on GND	Value = \$7FFF
Open Connection on slider or $U_{pot}$ and GND	Value = \$7FFF
Recognition Time for Open Slider	<3 s
Software Evaluation	Evaluation using configuration word 12 (module status)
Digital Converter Resolution	13 Bit

<b>Module ID</b>	<b>AI294</b>
Quantization; LSB Value (13 bit)	0.55 mV
Data Format Delivered to the Application Program	2s complement (16 bit representation)
Slider Voltage GND	Value = \$0000
Slider Voltage $U_{pot}$	Value = \$7FFF
Potentiometer Feed Voltage $U_{pot}$	+ 4.5 V $\pm$ 3 % at 40 mA
Short Circuit and Overload Protection	Yes
Input Current	<0.2 $\mu$ A
Measurement Sensor	0.5 to 10 k $\Omega$ , Potentiometer
Measurement Range	0 V to $U_{pot}$
Conversion Method	Sample & Hold
Conversion Time	4 ms for all channels, also with active comparator
Analog Input Measurement Error	
Maximum Error at 25 °C	$\pm$ 0.04 % of full range
Temperature Coefficient	$\pm$ 20 ppm/°C of full range
Maximum Error over Complete Temperature Range	$\pm$ 0.07 % of full range
Sensor Type	Isolated
Protection	RC protection
Internal Power Consumption	Max. 0.5 W
<b>Dynamic Characteristics</b>	
Application Scan Time	4 - 100 ms
Scan Repeat Time for Comparator Input	125 $\mu$ s
Response Time 1 LSB	Approx. 200 $\mu$ s
Input Filter Characteristics	
Attenuation	>40 dB/Dec
Transition / Cut-off Frequency	5 kHz
Signal Delay because of Input Filter under Following Conditions	3 to 10 $\mu$ s
Slider Speed	1 m/s
Pot	2 k $\Omega$
Path Length	100 mm
<b>Operating Characteristics</b>	
Isolation Voltage under Normal Operating Conditions between Channel and Bus	No electrical isolation
Missing Codes	Yes, because compensation and modification of the convertor resolutions takes place using a standard format
Non-linearity	$\pm$ 0.06 % of full range
<b>Mechanical Properties</b>	
Dimensions	B&R 2003 screw-in module

### 10.5.2 General Information

The AI294 is a 4 channel analog input module. It is used to evaluate potentiometer displacement gauges.

### 10.5.3 Special Functions

A threshold value can be defined for any channel. A bit in configuration word 12 indicates the status.

### 10.5.4 Input Circuit Diagram

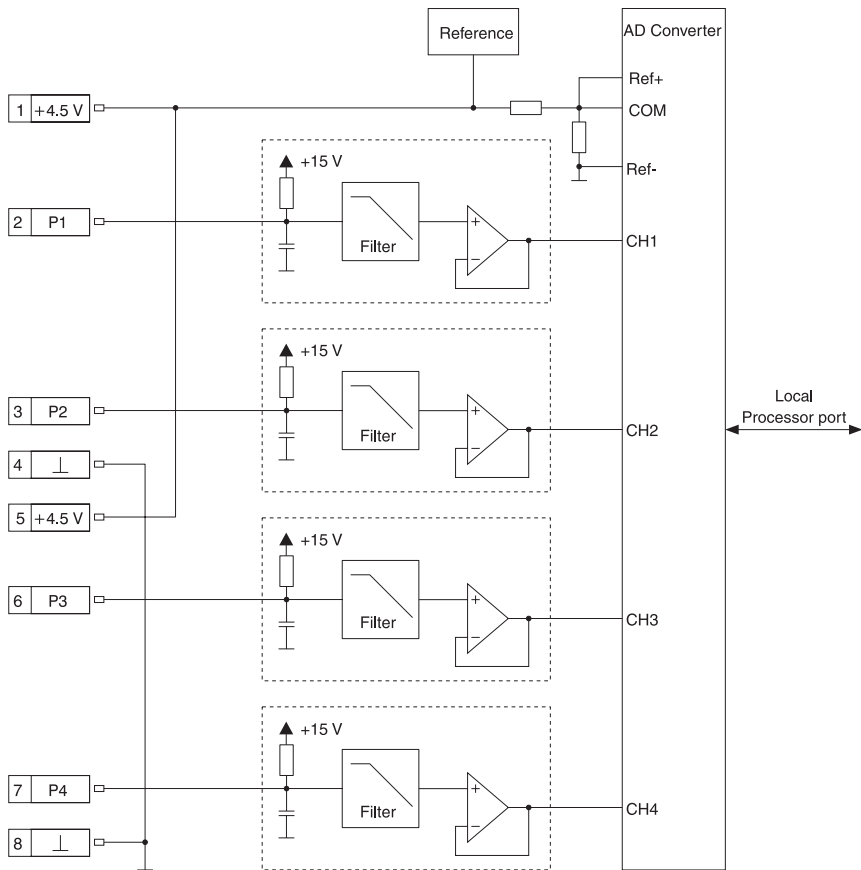

## 10.5.5 Connection

### Terminal Assignments

Connection	Designation	Description
1	+4.5 V	$U_{pot} = +4.5 \text{ V} \dots$ Supply for pot 1 and 2
2	P1	Slider potentiometer 1
3	P2	Slider potentiometer 2
4	⊥	GND
5	+4.5 V	$U_{pot} = +4.5 \text{ V} \dots$ Supply for pot 3 and 4
6	P3	Slider potentiometer 3
7	P4	Slider potentiometer 4
8	⊥	GND

### Wiring a Potentiometer Displacement Gauge

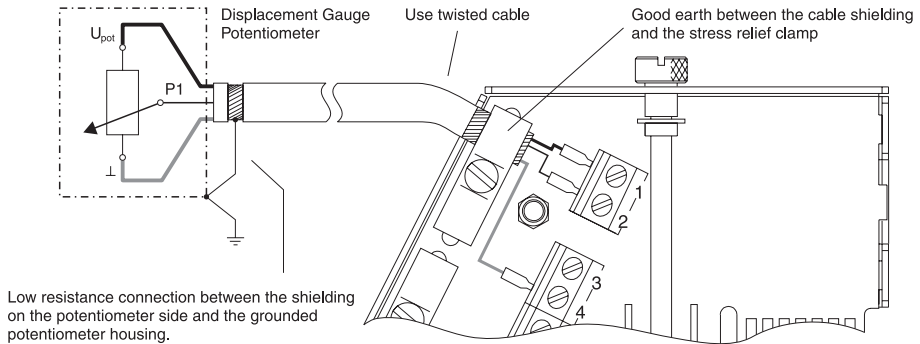

### Switching Circuit for All Four Potentiometer Displacement Gauges

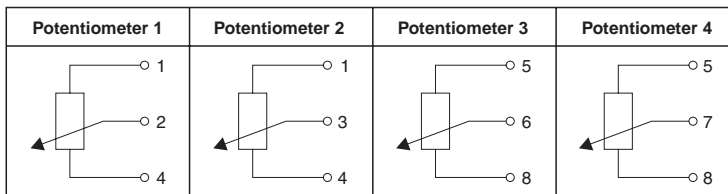

### 10.5.6 Variable Declaration

The variable declaration is valid for the following controllers:

- 2003 PCC CPU
- Remote I/O Bus Controller
- CAN Bus Controller

The variable declaration is made in PG2000. The variable declaration is described in Chapter 4, "Module Addressing".

Automation Studio™ Support:                    See Automation Studio™ Help starting with V 1.40

Accessing screw-in modules is also explained in the sections "AF101" and "CPU".

Data access takes place using data and configuration words. The following table provides an overview of which data and configuration words are used for this module.

Data Access	VD Data Type	VD Module Type	VD Chan.	R	W	Description
Data word 0	INT16	Analog In	1	●		Analog input value channel 1
Data word 1	INT16	Analog In	2	●		Analog input value channel 2
Data word 2	INT16	Analog In	3	●		Analog input value channel 3
Data word 3	INT16	Analog In	4	●		Analog input value channel 4
Configuration word 8	INT16	Transp. Out	16		●	Switching level for threshold value switch
Configuration word 12	WORD	Transp. In	24	●		Module status
Configuration word 14	WORD	Transp. In	28	●		Module type
	WORD	Transp. Out	28		●	Module configuration

### 10.5.7 Access using CAN Identifiers

Access via CAN Identifiers is used if the slave is being controlled by a device from another manufacturer. Access via CAN Identifiers is described in an example in Chapter 4, "Module Addressing". The transfer modes are explained in Chapter 5, "CAN Bus Controller Functions".

Data cannot be packed on the AI294. Therefore one CAN object is transferred per screw-in module. If an adapter module AF101 is equipped with a four AI294 modules, the CAN object has the following structure:

Slot	CAN ID <sup>1)</sup>	Word 1		Word 2		Word 3		Word 4	
1	542	Chan. 1L	Chan. 1H	Chan. 2L	Chan. 2H	Chan. 3L	Chan. 3H	Chan. 4L	Chan. 4H
2	543	Chan. 1L	Chan. 1H	Chan. 2L	Chan. 2H	Chan. 3L	Chan. 3H	Chan. 4L	Chan. 4H
3	544	Chan. 1L	Chan. 1H	Chan. 2L	Chan. 2H	Chan. 3L	Chan. 3H	Chan. 4L	Chan. 4H
4	545	Chan. 1L	Chan. 1H	Chan. 2L	Chan. 2H	Chan. 3L	Chan. 3H	Chan. 4L	Chan. 4H

<sup>1)</sup> CAN ID = 542 + (nd - 1) x 16 + (ma - 1) x 4 + (sl - 1)

nd ..... Node number of the CAN slave = 1

ma ..... Module address of the AF101 = 1

sl ..... Slot number of the screw-in module on the AF101 (1 - 4)



**B&R 2000 users have to exchange the data so that the high data is first (Motorola format)!**

For more information on ID allocation, see Chapter 5, "CAN Bus Controller Functions".

### 10.5.8 Description of Data and Configuration Words

#### Data word 0, 1, 2, 3 (read)

16 bit standardized values for the divider ratio, referring to the potentiometer supply.

#### Configuration Word 8 (write)

Value of the switching level for the threshold value switch (16 bit, signed).

### Configuration Word 12 (read)

Configuration word 12 contains the module status.

		Bit	Description	
		12 - 15	x.... Not defined, masked out	
		11	0.... Converter values ready 1.... Converter values not yet ready	
		10	x.... Not defined, masked out	
		9	0.... Potentiometer supply OK 1.... Overload of potentiometer supply	
		8	0.... Potentiometer supply OK 1.... Short circuit in the potentiometer supply	
		7	Comparator status 0.... if the value < threshold value 1.... if the value ≥ threshold value	
		4 - 6	x.... Not defined, masked out	
		3	0.... Channel 4: No error 1.... Channel 4: Error present	
		2	0.... Channel 3: No error 1.... Channel 3: Error present	
		1	0.... Channel 2: No error 1.... Channel 2: Error present	
		0	0.... Channel 1: No error 1.... Channel 1: Error present	
		15	x	
		14	x	
		13	x	
		12	x	
11	x			
10				
9				
8				
7				
6				
5				
4				
3				
2				
1				
0				

### Configuration Word 14 (read)

The High Byte of configuration word 14 defines the module code.

		Bit	Description
		8 - 15	Module code = \$22
		0 - 7	x.... Not defined, masked out
15	0		
14	0		
13	1		
12	0		
11	0		
10	0		
9	0		
8	1		
7	0		
6	x		
5	x		
4	x		
3	x		
2	x		
1	x		
0	x		

### Configuration Word 14 (write)

The module is configured using configuration word 14.

		Bit	Description
		15	0.... TPU operation switched off 1.... TPU operation switched on To be able to use TPU operation, the module must be operated on the CP Interface.
		11 - 14	0
		10	0.... Operation without threshold value switch 1.... Operation with threshold value switch The time resolution of the comparator is 125 µs. During operation with threshold value switch and TPU operation switched on (Bit 15 = 1), the status of Bit 7 in configuration word 12 is copied to the TPU OUT line. The TPU OUT line can be operated using LTX functions (e.g. LTXdi1()).
		8 - 9	Selection of channels for the threshold value switch 0.... Channel 1 1.... Channel 2 2.... Channel 3 3.... Channel 4
		0 - 7	0
15	0 0 0 0	8 7	0 0 0 0 0 0 0 0
		0	