

# INSTRUCTION MANUAL

## FOR

### VOLTAGE PHASE SEQUENCE RELAY

#### BE1-47N

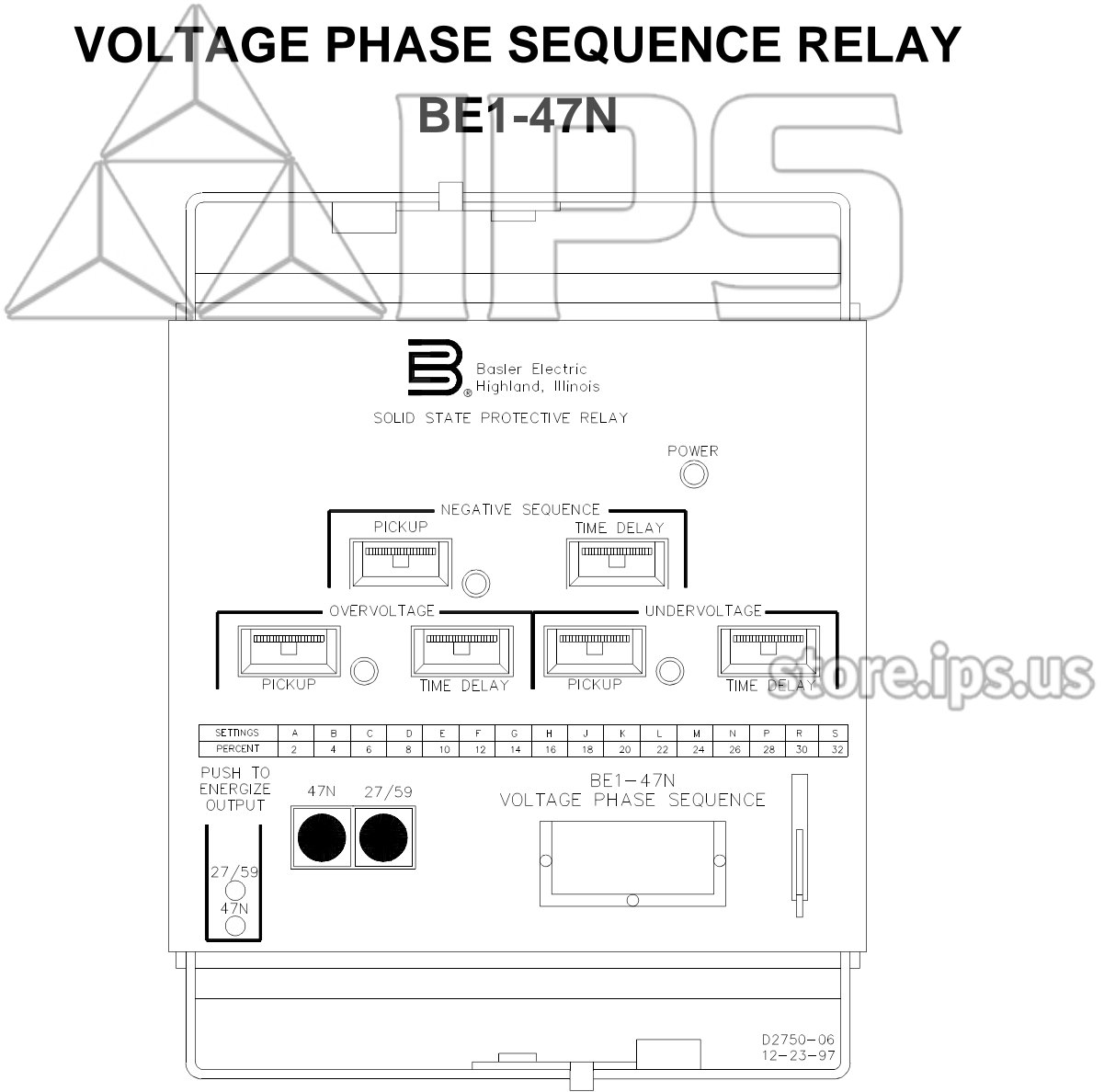

# **B** Basler Electric

Publication: 9 1704 00 990

Revision: F 02/01

## INTRODUCTION

This Instruction Manual provides information concerning the operation and installation of BE1-47N Voltage Phase Sequence Relay. To accomplish this, the following is provided.

- Specifications
- Functional characteristics
- Installation
- Operational Tests
- Mounting Information

store.ips.us

### **WARNING**

To avoid personal injury or equipment damage, only qualified personnel should perform the procedures presented in this manual.

First Printing: September 1985

Printed in USA

© 1998, 2001 Basler Electric Co., Highland, IL 62249

February 2001

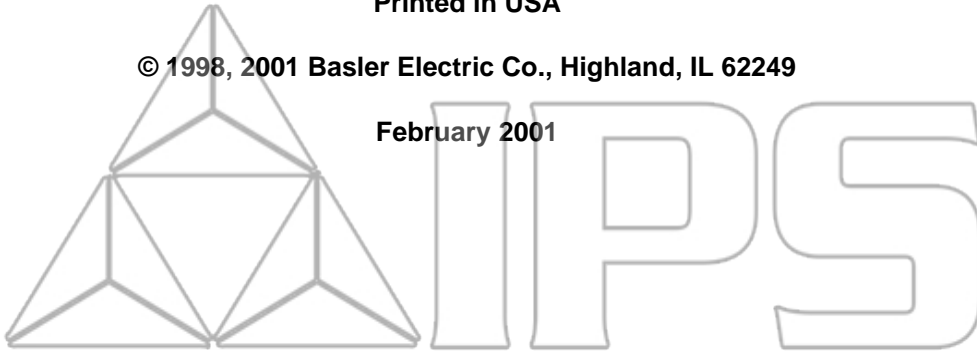

CONFIDENTIAL INFORMATION

OF BASLER ELECTRIC COMPANY, HIGHLAND, IL. IT IS LOANED FOR CONFIDENTIAL USE, SUBJECT TO RETURN ON REQUEST, AND WITH THE MUTUAL UNDERSTANDING THAT IT WILL NOT BE USED IN ANY MANNER DETRIMENTAL TO THE INTEREST OF BASLER ELECTRIC COMPANY.

store.ips.us

It is not the intention of this manual to cover all details and variations in equipment, nor does this manual provide data for every possible contingency regarding installation or operation. The availability and design of all features and options are subject to modification without notice. Should further information be required, contact Basler Electric Company, Highland, Illinois.

**BASLER ELECTRIC  
ROUTE 143, BOX 269  
HIGHLAND, IL 62249 USA**

**<http://www.basler.com>, [info@basler.com](mailto:info@basler.com)**

**PHONE 618-654-2341**

**FAX 618-654-2351**

# CONTENTS

<b>SECTION 1</b>	<b>GENERAL INFORMATION</b> .....	<b>1-1</b>
	Purpose .....	1-1
	Application .....	1-1
	Phase Rotation Sensitivity .....	1-1
	Model And Style Number .....	1-2
	Sample Style Number .....	1-2
	Specifications .....	1-4
<b>SECTION 2</b>	<b>HUMAN-MACHINE INTERFACE (CONTROLS AND INDICATORS)</b> .....	<b>2-1</b>
<b>SECTION 3</b>	<b>FUNCTIONAL DESCRIPTION</b> .....	<b>3-1</b>
	General .....	3-1
	Voltage Sensing .....	3-1
	Phase Shifting .....	3-1
	Pickup Scaling .....	3-1
	Low-Pass Filter .....	3-2
	Negative Sequence Voltage Comparator .....	3-2
	Over/Undervoltage Comparator .....	3-2
	Timing .....	3-2
	Outputs .....	3-2
	Indicators .....	3-2
	Targets .....	3-2
	Power Supply .....	3-3
	Power Supply Status Output .....	3-3
<b>SECTION 4</b>	<b>INSTALLATION</b> .....	<b>4-1</b>
	General .....	4-1
	Relay Operating Precautions .....	4-1
	Dielectric Test .....	4-1
	Mounting .....	4-1
	Connections .....	4-9
<b>SECTION 5</b>	<b>OPERATIONAL TEST</b> .....	<b>5-1</b>
	General .....	5-1
	Operational Test Procedures .....	5-1
	Negative Sequence Voltage Pickup and Dropout .....	5-1
	Overvoltage Pickup and Dropout .....	5-2
	Undervoltage Pickup and Dropout .....	5-3
	Verification Tests .....	5-3
	Definite Time Verification .....	5-3
	Inverse Time Verification .....	5-3
<b>SECTION 6</b>	<b>MAINTENANCE</b> .....	<b>6-1</b>
	General .....	6-1
	In-House Repair .....	6-1
	Storage .....	6-1
<b>SECTION 7</b>	<b>MANUAL CHANGE INFORMATION</b> .....	<b>7-1</b>
	Changes .....	7-1

# SECTION 1 • GENERAL INFORMATION

---

## PURPOSE

BE1-47N Voltage Phase Sequence Relays respond to negative sequence voltage ( $V_2$ ) which results from a fault or misconnection on a balanced, three-phase system.

---

## APPLICATION

BE1-47N relays are designed to protect equipment from damage caused by phase failure, reverse phase sequence, phase unbalance, undervoltage, or overvoltage.

The relay detects reverse phase connection of lines, transformers, motors, generators, and synchronous condensers and is often applied in automatic transfer schemes to assure connection of proper phase rotation as well as voltage conditions. When used in motor protection, the relay will provide protection by preventing start-up of the motor for open phase or reverse phase condition and by tripping the motor off line for phase unbalance, undervoltage or overvoltage conditions.

Negative sequence voltage is the result of any unequal phase condition on the source. This can be due to unequal single phase loads on the system or unequal transformer impedances between the phases. A 1%-2% level can normally be expected in an industrial supply. Any significant increase above this level can be an indication of a power service problem and could lead to serious plant problems. The BE1-47N has the ability to detect negative sequence voltage levels of this magnitude.

Undervoltage and voltage balance relays have traditionally been applied for the protection of induction motors from operating with one phase open. These relays may not reliably detect this condition due to the back emf of the motor on the open phase. However, an induction motor, with a starting current of 6 per unit, will generate a negative sequence voltage of 16% if fully loaded when a fuse blows. The negative sequence voltage will be somewhat reduced if the motor is not fully loaded. The sensitivity of the BE1-47N and its insensitivity to frequency allow reliable protection to be applied to motors.

Motor losses and current unbalance increase with the negative sequence voltage level. The increased loss due to negative sequence voltage is not a function of motor load but is independent. A machine operating with 3.5% negative sequence voltage will have its losses increased by 25%. A blown fuse on a power factor correction capacitor bank can result in significant negative sequence voltage increase. The effect of this condition can be costly.

BE1-47N relays can be applied to protect motor buses from an open phase. It can also be applied to protect critical individual motors, static, and nonrotating loads from the effects of negative sequence voltage.

A choice of time delay characteristics allows the relay to respond in the desired manner for a wide variety of transient and fault conditions.

BE1-47N relays may also be used to provide over/undervoltage protection as well. A separate time delay is utilized to prevent shutdown of equipment for minor voltage dips and to permit sequential operation when the relay is being used in a supervisory capacity.

---

## PHASE ROTATION SENSITIVITY

Relays that operate using phase-to-phase voltage to determine negative sequence are sensitive to phase rotation. BE1-47N Voltage Phase Sequence relays are phase rotation sensitive. Unless otherwise noted, all connections shown in this manual assume ABC rotation.

## MODEL AND STYLE NUMBER

BE1-47N Voltage Phase Sequence Relays electrical characteristics and operational features are defined by a combination of letters and numbers that make up the style number. The model number BE1-47N designates the relay as a Basler Electric, Class 100, Voltage Phase Sequence Relay. The model number, together with the style number, describe the options included in a specific device, and appear on the front panel, drawout cradle, and inside the case assembly. Upon receipt of a relay, be sure to check the style number against the requisition and the packing list to ensure that they agree.

## SAMPLE STYLE NUMBER

Style number identification chart (Figure 1-1) defines the electrical characteristics and operational features included in BE1-47N relays. For example, if the model number of the relay was BE1-47N, and the style number was E3F-E1P-A1R0F the device would have the following features:

- E - Three-phase (Line-to-Line) voltage sensing
- 3 - Sensing range is 120V/60 hertz nominal
- F - Two output relays with normally open contacts
- E1 - Definite time timing characteristics
- P - 125 Vdc power supply
- A - One internally operated target
- 1 - Instantaneous undervoltage element
- R - Instantaneous overvoltage element
- 0 - No auxiliary output relay
- F - Semi-flush mounting case

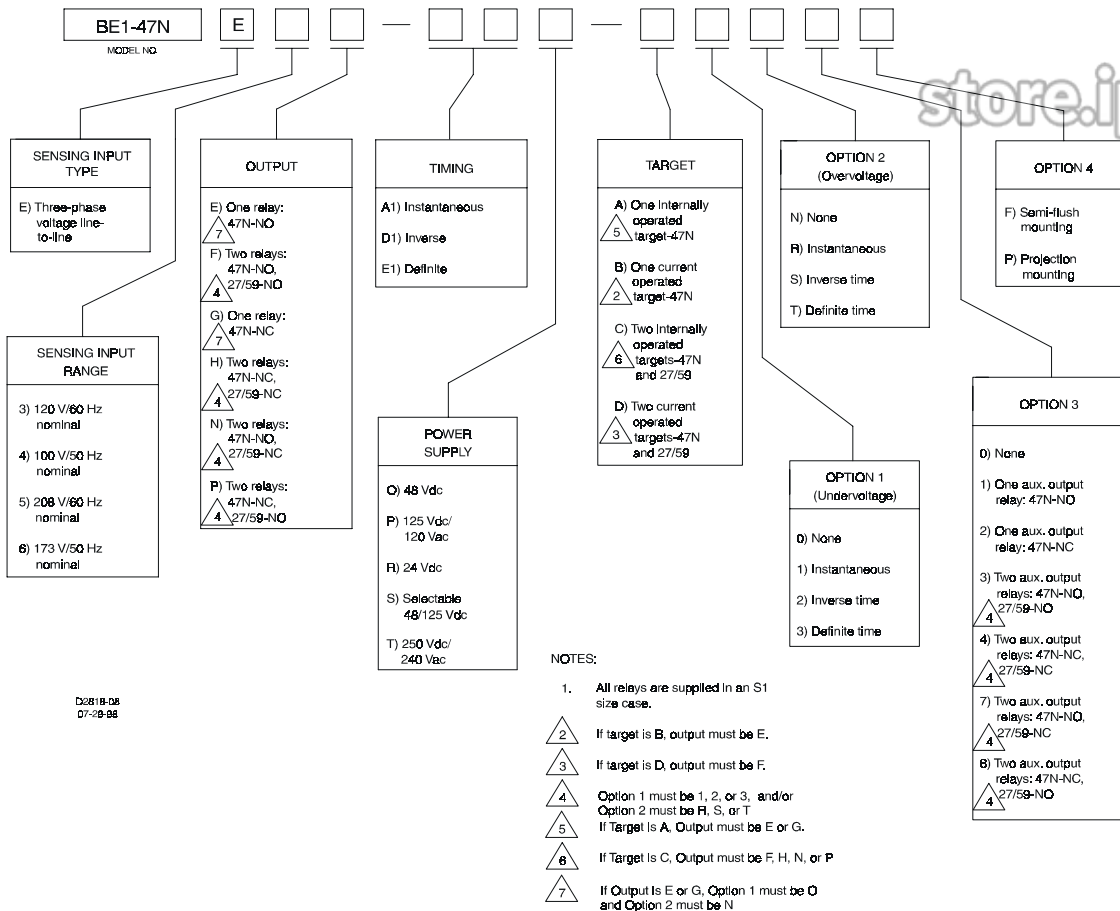

Figure 1-1. Style Identification Chart

## SPECIFICATIONS

### Voltage Sensing

Nominally rated at 50/60 Hz, (120/208 V or 100/173 V) with a maximum continuous voltage rating of 160% of nominal at 2 VA burden maximum per phase. Frequency range is 45-55 Hz for 50 Hz systems, 55-65 Hertz for 60 Hertz systems.

### Power Supply

One of the five types of power supplies listed in Table 1-1 may be selected to provide internal relay operating power.

Table 1-1. Power Supply Types And Specifications

Type	Nominal Input Voltage	Input Voltage Range	Burden at Nominal
O (Mid Range)	48 Vdc	24 to 150 Vdc	4.0 W
P (Mid Range)	125 Vdc 120 Vac	24 to 150 Vdc 90 to 132 Vac	4.1 W 10.0 VA
R (Low Range)	24 Vdc	12 † to 32 Vdc	4.0 W
S (Mid Range)	48 Vdc 125 Vdc	24 to 150 Vdc 24 to 150 Vdc	4.0 W 4.1 W
T (High Range)	250 Vdc 240 Vac	62 to 280 Vdc 90 to 270 Vac	5.0 W 12.0 VA

† Type R power supply initially requires 14 Vdc to begin operating. Once operating, the voltage may be reduced to 12 Vdc and operation will continue.

### Target Indicators

Magnetically latched, manually reset target indicators are optionally available to indicate that the trip output contacts have energized. Either internally operated or current operated targets may be specified. A current operated target requires a minimum of 0.2 A flowing through the output trip circuit, and is rated at 30 A for 1 second, 7 A for 2 minutes and 3 A continuous. The internally operated target should be selected if the relay has normally closed output contacts.

### Negative Sequence Voltage

Adjustable over the range of 2 to 32% Pickup in increments of 2%. Pickup accuracy is within  $\pm 1$  unit of the percent setting of the negative sequence voltage at nominal frequency (50 or 60 hertz as defined by the style number).

### Negative Sequence Voltage Dropout

98% of pickup

## Negative Sequence Voltage

### Time Delay

Definite Time: Adjustable by front-panel switch over the range of 0.1 to 9.9 seconds in increments of 0.1 seconds. Accuracy within  $\pm 5\%$  or  $\pm 50$  ms (whichever is greater) of the time selected by the switch.

Inverse Time: Adjustable over the range of 01 to 99 in increments of 1. Accuracy within  $\pm 5\%$  or  $\pm 50$  ms (whichever is greater) of the indicated time of the selected time-dial curve as plotted in Figure 3-3.

Instantaneous Time: Less than 50 ms.

### Undervoltage Pickup

Adjustable from 2 to 32% below nominal in increments of 2% with an accuracy of  $\pm 1\%$  of the voltage pickup setting.

### Undervoltage Dropout

98% of pickup.

### Undervoltage Time Delay

Definite Time: Adjustable over the range of 0.1 to 9.9 seconds in increments of 0.1 seconds, with an accuracy of  $\pm 5\%$  of the time selected.

Inverse Time: Adjustable over the range of 01 to 99 in increments of 1. Accuracy within  $\pm 5\%$  or  $\pm 50$  ms (whichever is greater) of the indicated time of the selected time-dial curve as plotted in Figure 3-4.

Instantaneous Time: Less than 50 ms.

### Overvoltage Pickup

Adjustable from 2 to 32% above nominal in increments of 2% with an accuracy of  $\pm 1\%$  of the voltage pickup setting.

### Overvoltage Dropout

98% of pickup.

### Overvoltage Time Delay

Definite Time: Adjustable over the range of 0.1 to 9.9 seconds in increments of 0.1 seconds, with an accuracy of  $\pm 5\%$  of the time selected.

Inverse Time: Adjustable over the range of 01 to 99 in increments of 1. Accuracy within  $\pm 5\%$  or  $\pm 50$  ms (whichever is greater) of the indicated time of the selected time-dial curve as plotted in Figure 3-5.

Instantaneous Time: Less than 50 ms.

**Outputs**

Output contacts are rated as follows:

Resistive

120/240 Vac - Make 30 A for 0.2 seconds, carry 7 A continuously, and break 7 A.

250 Vdc - Make and carry 30 A for 0.2 seconds, carry 7 A continuously, and break 0.3 A.

500 Vdc - Make and carry 15 A for 0.2 seconds, carry 7 A continuously, and break 0.1 A.

Inductive

120/240 Vac, 125/250 Vdc - Make and carry 30 A for 0.2 seconds, carry 7 A continuously, and break 0.3 A (L/R = 0.04).

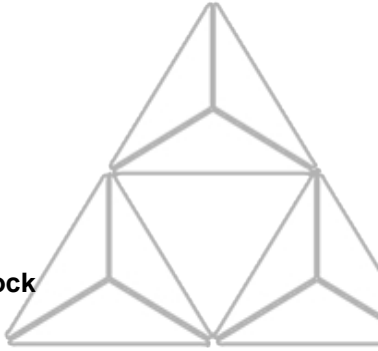
**Shock**

In standard tests, the relay has withstood 15 g in each of three mutually perpendicular planes without structural damage or degradation of performance.

**Vibration**

In standard tests, the relay has withstood 2 g in each of three mutually perpendicular planes, swept over the range of 10 to 500 hertz for a total of six sweeps, 15 minutes each sweep, without structural damage or degradation of performance.

**Isolation**

In accordance with IEC 255-5 and ANSI/IEEE C37.90, one minute dielectric (high potential) tests as follows:

All circuits to ground: 2121 Vdc  
 Input to output circuits: 1500 Vac or 2121 Vdc

**UL Recognized**

UL Recognized per Standard 508, UL File No. E97033. Note: Output contacts are not UL Recognized for voltages greater than 250 volts.

**Radio Frequency Interference (RFI)**

Maintains proper operation when tested for interference in accordance with IECC C37.90-1989, Trial-Use Standard Withstand Capability of Relay systems to Radiated electromagnetic Interference from Transceivers.

**Surge Withstand Capability**

Qualified to ANSI/IEEE C37.90.1-1989 Standard Surge Withstand Capability (SWC) Tests for Protective Relays and Relay Systems.

**Fast Transient**

Qualified to ANSI/IEEE C.37.90.1-198X,

**Impulse Test**

Qualified to IEC 255-5.

**Temperature**

Operating  
 Storage

-40°C (-40°F) to 70°C (158°F)  
 -65°C (-85°F) to 100°C (212°F)

**Weight**

14.0 pounds

**Case Size**

S1

## SECTION 2 • HUMAN-MACHINE INTERFACE (CONTROLS AND INDICATORS)

The following table is referenced to Figure 2-1.

LOCATOR	CONTROL OR INDICATOR	FUNCTION
A	NEGATIVE SEQUENCE PICKUP	Sixteen-position thumbwheel switch which provides adjustment of voltage pickup point over the range of 2 to 32% of the nominal voltage, in increments of 2%. Settings correspond to percentage levels as indicated on the front panel.
B	NEGATIVE SEQUENCE	Red LED turns ON when level of NEGATIVE SEQUENCE voltage exceeds pickup setting.
C	NEGATIVE SEQUENCE TIME DELAY	Thumbwheel switch provides adjustment of the inverse, definite or instantaneous TIME DELAY for the Negative Sequence Voltage function (See Specifications for ranges and accuracies.)
D	POWER Indicator	Red LED turns ON when operating power for internal circuitry is provided.
E	UNDERVOLTAGE PICKUP	Sixteen-position thumbwheel switch that provides adjustment of the UNDERVOLTAGE PICKUP point, from 2 to 32% below nominal in increments of 2%. Settings correspond to percentage levels as indicated on the front panel.
F	UNDERVOLTAGE Indicator	Red LED turns ON when system voltage falls below UNDERVOLTAGE pickup setting.
G	UNDERVOLTAGE TIME DELAY	Thumbwheel switch provides adjustment of inverse, definite, or instantaneous TIME DELAY for the Undervoltage function (See Specifications for ranges and accuracies.)
H	Target Reset Lever	Provides manual reset of target indicators.
I	27/59 Target Indicator	Red target indicates when overvoltage or undervoltage output relay has energized. Must be manually reset.
J	PUSH-TO-ENERGIZE Pushbuttons	Provides manual energization of the output relays by insertion of a 1/8 inch non-conduction rod through the access hole in the front panel; for testing the external trip circuit.
K	47N Target Indicator	Red target indicates when negative sequence voltage output relay has energized. Must be manually reset.

L	OVERVOLTAGE PICKUP	Sixteen-position thumbwheel switch that provides adjustment of the OVERVOLTAGE PICKUP point, from 2 to 32% above nominal in increments of 2%. Settings correspond to percentage levels as indicated on the front panel.
M	OVERVOLTAGE Indicator	Red LED turns ON when system voltage exceeds the OVERVOLTAGE pickup setting.
N	OVERVOLTAGE TIME DELAY	Thumbwheel switch provides adjustment of inverse, definite, or instantaneous TIME DELAY for the Overvoltage function (See Specifications for ranges and accuracies.)

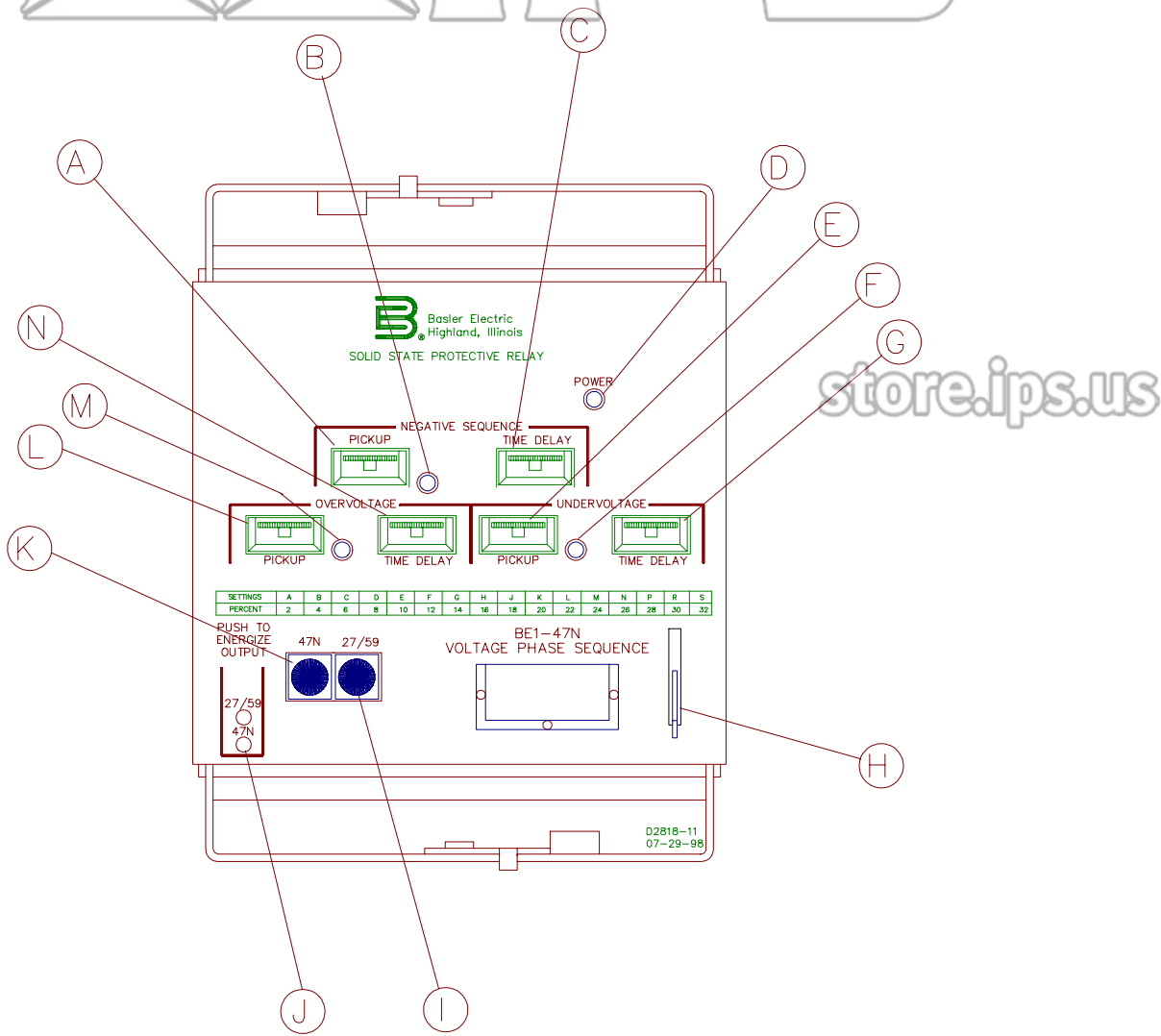

Figure 2-1. Location of Controls and Indicators

# SECTION 3 • FUNCTIONAL DESCRIPTION

## General

The following descriptions are referenced to the Functional Block Diagram, Figure 3-1 below .

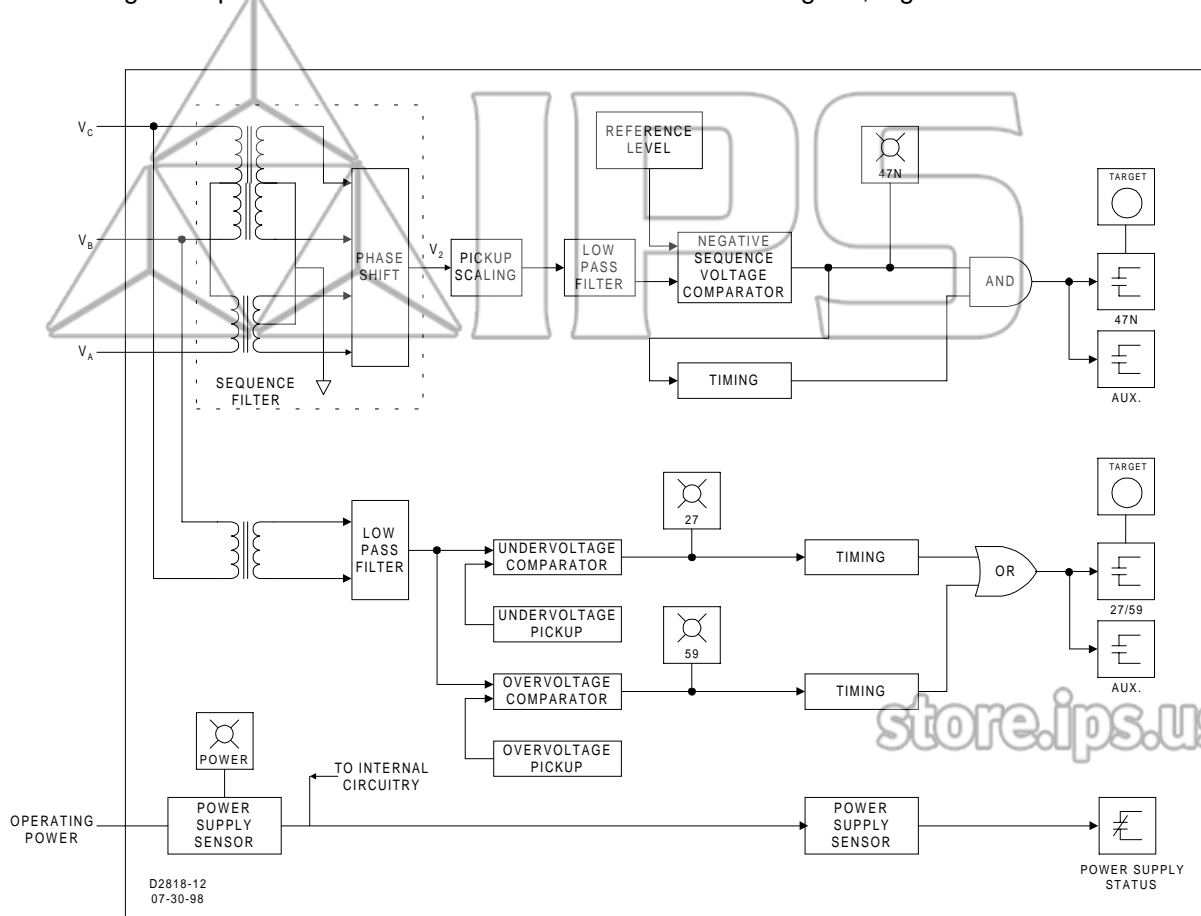

Figure 3-1. Functional Block Diagram

## VOLTAGE SENSING

### Negative Sequence Voltage

Three-phase system voltage is supplied to 120/208V, 100/173V nominal, 50/60 hertz potential transformers (PTs). These PTs are an integral part of the sequence filter and provide isolation, step-down scaling, and phasor summation to eliminate the zero sequence component of the sensed voltages.

## PHASE SHIFTING

The respective secondary voltages are phase shifted  $\pm 45^\circ$  each, with respect to signal ground and then summed to nullify the positive sequence component.

## PICKUP SCALING

The resolved negative sequence voltage ( $V_2$ ) ac signal is then applied to the PICKUP scaling network (switch S1 and its associated resistors). The PICKUP network establishes per unit (p.u.) values of  $V_2$  for the

comparison and timing functions.

---

## LOW-PASS FILTER

The sensing circuits for over/undervoltage and negative sequence voltage are designed to operate on the fundamental frequencies of 50 or 60 hertz. The low-pass filter is provided to pass the fundamental frequencies and attenuate the higher ones.

---

## NEGATIVE SEQUENCE VOLTAGE COMPARATOR

The proportionate negative sequence ( $V_2$ ) signal is compared to a reference level. When the level of the per unit  $V_2$  exceeds the reference level, the pickup indicator is illuminated and timing initiated.

---

## OVER/UNDERVOLTAGE COMPARATOR

Optional single-phase over and undervoltage circuits operate on the voltage magnitude. The single-phase ac signal is low-pass filtered and passed to the respective comparator where it is compared to the PICKUP settings for each circuit. If either PICKUP setting has been exceeded (over or undervoltage) the appropriate LED is turned ON and timing initiated.

---

## TIMING

Three timing characteristics are optionally available; inverse time, definite time and instantaneous time (no intentional delay). Timing for all three functions (47N - negative sequence voltage, 27 - undervoltage, 59 - overvoltage) is completely independent and may be selected independently for each function. Definite Time is adjustable from 0.1 to 9.9 seconds in increments of 0.1 seconds. Inverse Time is adjustable from 01 to 99 in increments of 1 (see Figures 3-2 through 3-4 Inverse Time Characteristic Curves). Instantaneous Time is designated by a Time Delay setting of 00. Instantaneous response time is less than 50 milliseconds.

When evaluating inverse curves for the overvoltage or undervoltage function of the relay, it should be noted that timing is based on the percent difference from system nominal. For example, refer to Figure 3-4. If the monitored voltage was at a level that was 18% below system nominal, the portion of the curves below 18% (i.e. 13%, 8%, etc.) has no effect on the units timing characteristics. In other words, the timing curve beginning is dependent upon the monitored voltage percent difference from the system nominal voltage. Inverse timing characteristics preceding this defined point are non-existent.

---

## OUTPUTS

Output relays are provided for the trip functions (Negative Sequence Voltage and Under/Overvoltage).

Output relay contacts may be configured for normally open (NO) or normally closed (NC) operation. Auxiliary output relays that operate at the same time as the trip output relays are also available. (See Option 3 of the Style Chart).

---

## INDICATORS

LEDs are provided to indicate the power supply is operating and that a particular function (i.e. 47N, 27, or 59) has exceeded its pickup point and the unit is timing. One indicator is provided for each measuring function included within the relay.

---

## TARGETS

Magnetically latched, manually reset target indicators are optionally available for the functions and may be either internally operated (signal operated) or current operated (operated by a minimum of 0.2 Adc through the output trip circuit).



[store.ips.us](http://store.ips.us)

---

## POWER SUPPLY

Basler Electric enhanced the power supply design for unit case relays. This new design created three, wide range power supplies that replace the five previous power supplies. Style number identifiers for these power supplies have not been changed so that customers may order the same style numbers that they ordered previously. The first newly designed power supplies were installed in unit case relays with EIA date codes 9638 (third week of September 1996). Relays with a serial number that consists of one alpha character followed by eight numerical characters also have the new wide range power supplies. A benefit of this new design increases the power supply operating ranges such that the 48/125 volt selector is no longer necessary. Specific voltage ranges for the three new power supplies and a cross reference to the style number identifiers are shown in the following table.

*Table 3-1. Wide Range Power Supply Voltage Ranges*

Power Supply	Style Chart Identifier	Nominal Voltage	Voltage Range
Low Range	R	24 Vdc	12† to 32 Vdc
Mid Range	O, P, S	48, 125 Vdc, 120 Vac	24 to 150 Vdc 90 to 132 Vac
High Range	T	125, 250 Vdc, 120, 240 Vac	62 to 280 Vdc 90 to 270 Vac

† 14 Vdc required to start the power supply.

Relay operating power is developed by the wide range, isolated, low burden, flyback switching, solid state power supply. Nominal  $\pm 12$  Vdc is delivered to the relay internal circuitry. Input (source voltage) for the power supply is not polarity sensitive. A red LED turns ON to indicate that the power supply is functioning properly.

store.ips.us

---

## POWER SUPPLY STATUS OUTPUT

The power supply status output is a standard feature of the BE1-47N relay. The power supply status output relay has a set of normally closed (NC) contacts that are energized open upon power-up and remain open during proper power supply operation. If either or both of the power supply output legs (+12V or -12V) drops out, the power supply status output relay is de-energized (contact closed).

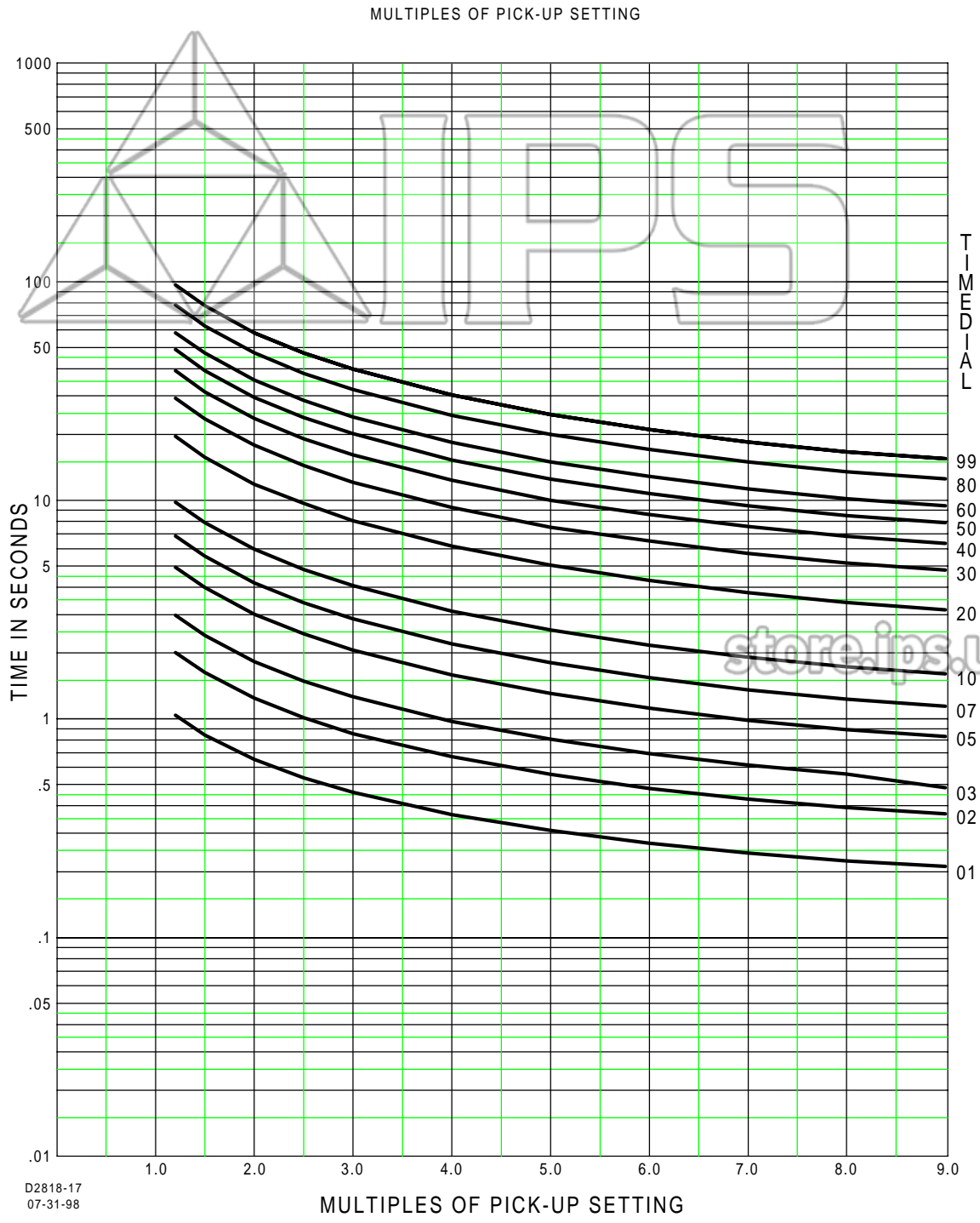

Figure 3-2. Negative Sequence Voltage Inverse Time Characteristic Curves

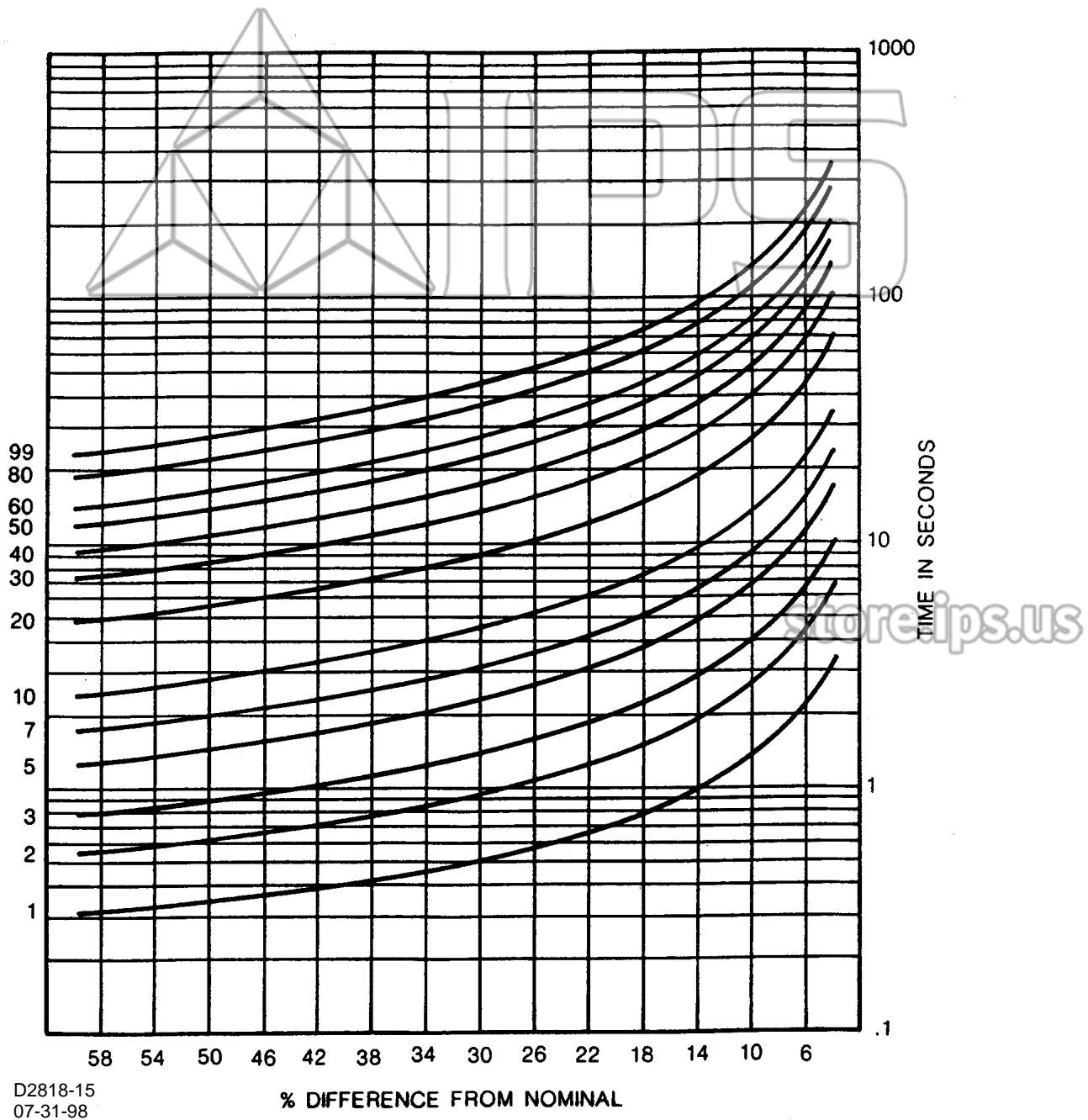

Figure 3-3. Undervoltage Inverse Time Characteristic Curves

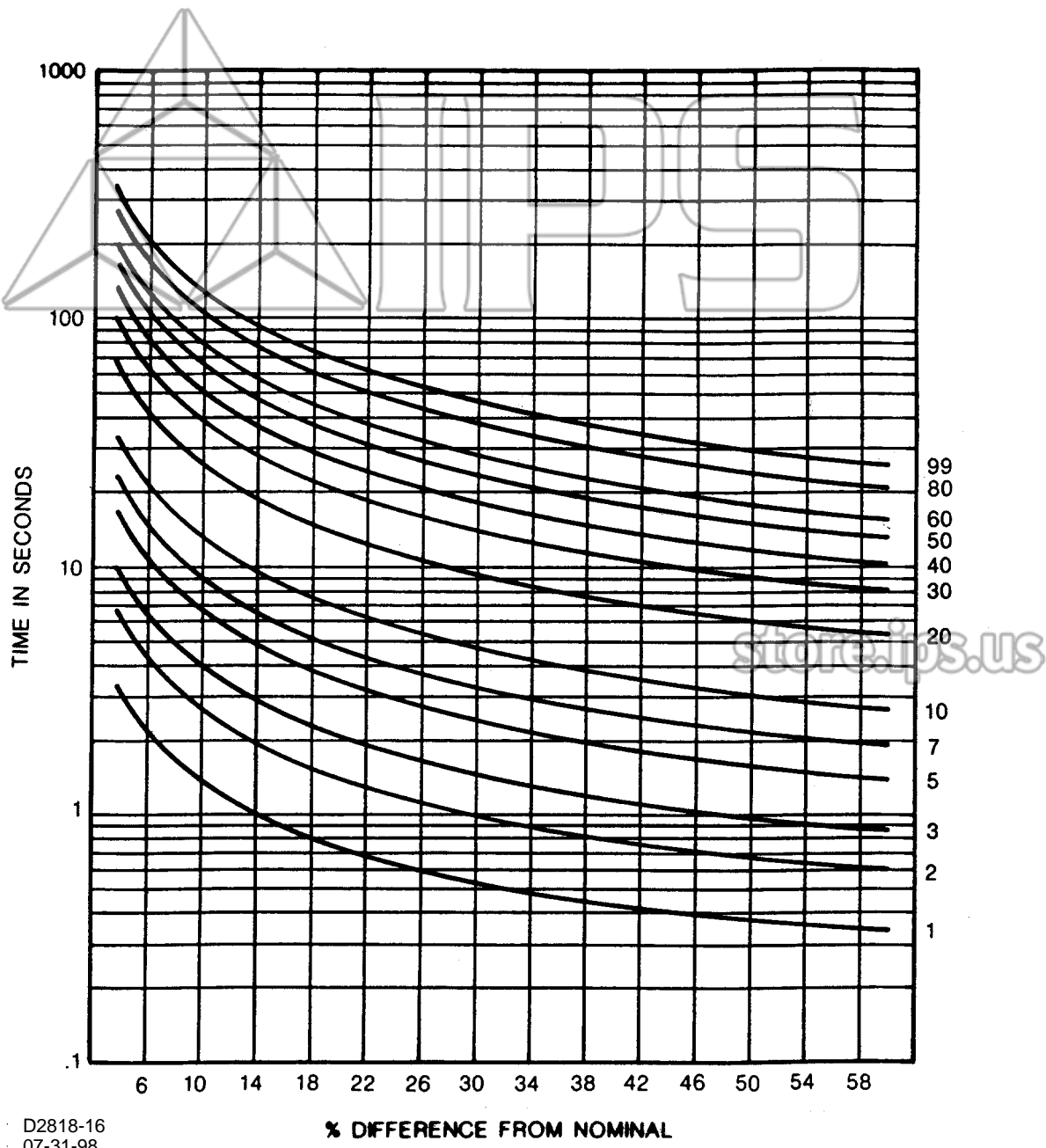

Figure 3-4. Overvoltage Inverse Time Characteristic Curves

# SECTION 4 • INSTALLATION

---

## GENERAL

When not shipped as part of a control or switchgear panel, the relay is shipped in a sturdy carton to prevent damage during transit. Immediately upon receipt of a relay, check the model and style number against the requisition and packing list to see that they agree. Visually inspect the relay for damage that may have occurred during shipment. If there is evident damage, immediately file a claim with the carrier and notify the Regional Sales Office, or contact the Sales Representative at Basler Electric, Highland, Illinois.

In the event the relay is not to be installed immediately, store the relay in its original shipping carton in a moisture and dust free environment. When relay is to be placed in service, it is recommended that the following operational test be performed prior to installation.

---

## RELAY OPERATING PRECAUTIONS

Before installation or operation of the relay, note the following precautions:

1. A minimum of 0.2 A in the output circuit is required to ensure operation of current operated targets.
2. The relay is a solid-state device and has been type tested in accordance with the requirements defined below under DIELECTRIC TEST. If a wiring insulation test is required on the panel assembly where this relay is to be installed, it is suggested that the connecting plugs of the relay be removed and the cradle withdrawn from the case so as not to produce false readings during the wiring insulation test.
3. When the connecting plugs are removed the relay is disconnected from the operating circuit and will not provide system protection. Always be sure that external operating (monitored) conditions are stable before removing a relay for inspection, test, or service. Also, be sure that connecting plugs are in place before replacing the front cover.
4. Be sure the relay case is hard wired to earth ground using the ground terminal on the rear of the unit. Use a separate ground lead to the ground bus for each relay.
5. An undervoltage target indication may occur when the lower connecting paddle is removed if:
  - a) the instantaneous time function is selected, or
  - b) a time delay (definite or inverse) below 0.3 seconds is selected.No actual trip output occurs if the upper paddle is removed first.

---

## DIELECTRIC TEST

In accordance with IEC 255-5 and ANSI/IEEE C37.90, one minute dielectric (high potential) tests as follows:

All circuits to ground:	2121 Vdc
Input to output circuits:	1500 Vac or 2121 Vdc

---

## MOUNTING

Because the relay is of solid state design, it does not have to be mounted vertically. Indeed, any convenient mounting angle may be chosen. Relay outline dimensions and panel drilling diagrams are in Figures 4-1 through 4-10.

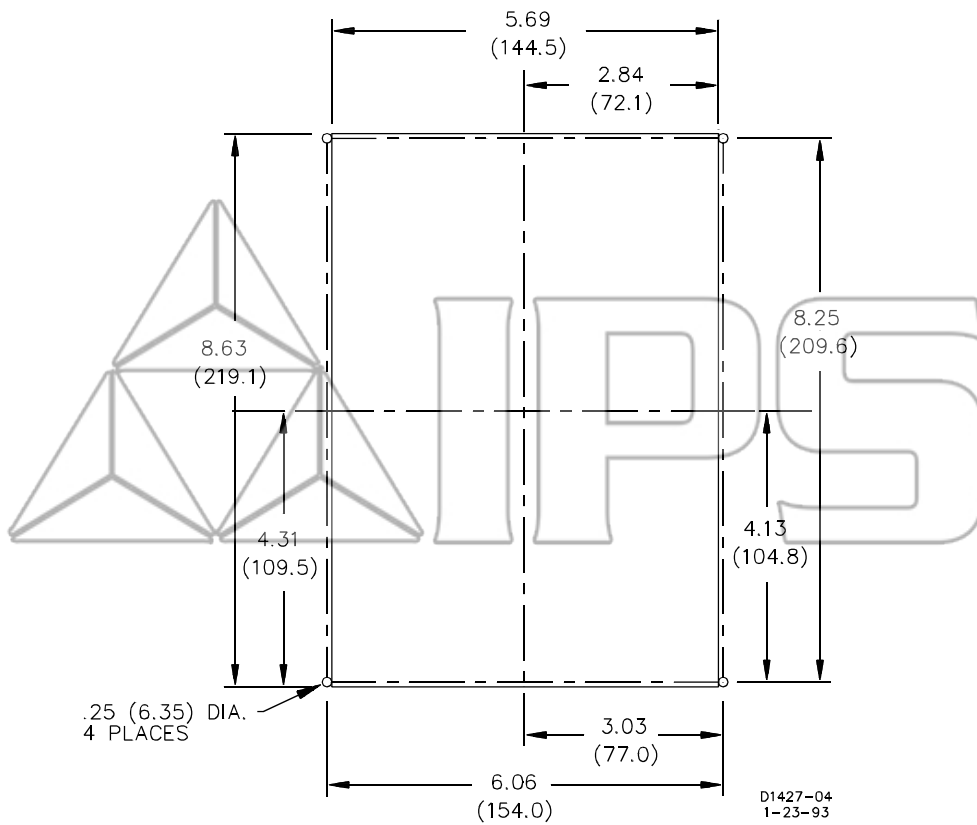

Figure 4-1. S1 Case, Panel Drilling Diagram, Semi-Flush Mounting

store.ips.us

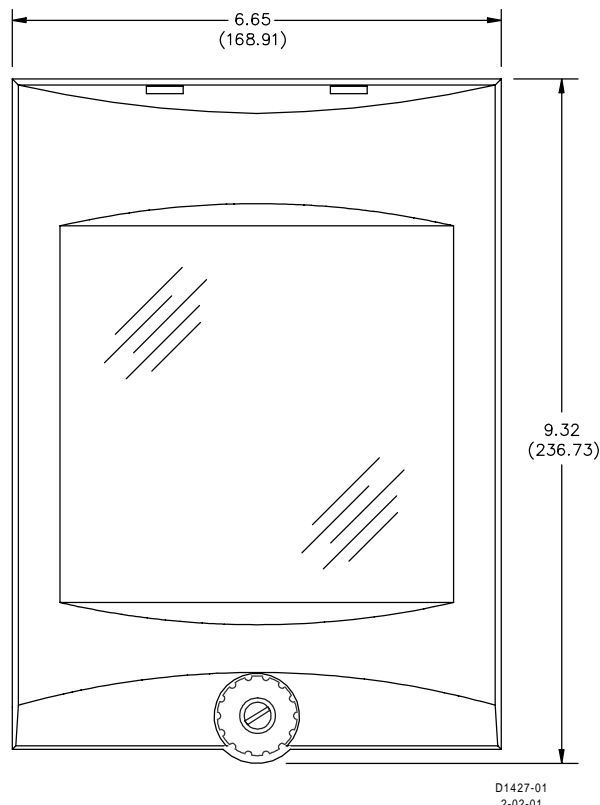

Figure 4-2. S1 Case, Outline Dimensions, Front View

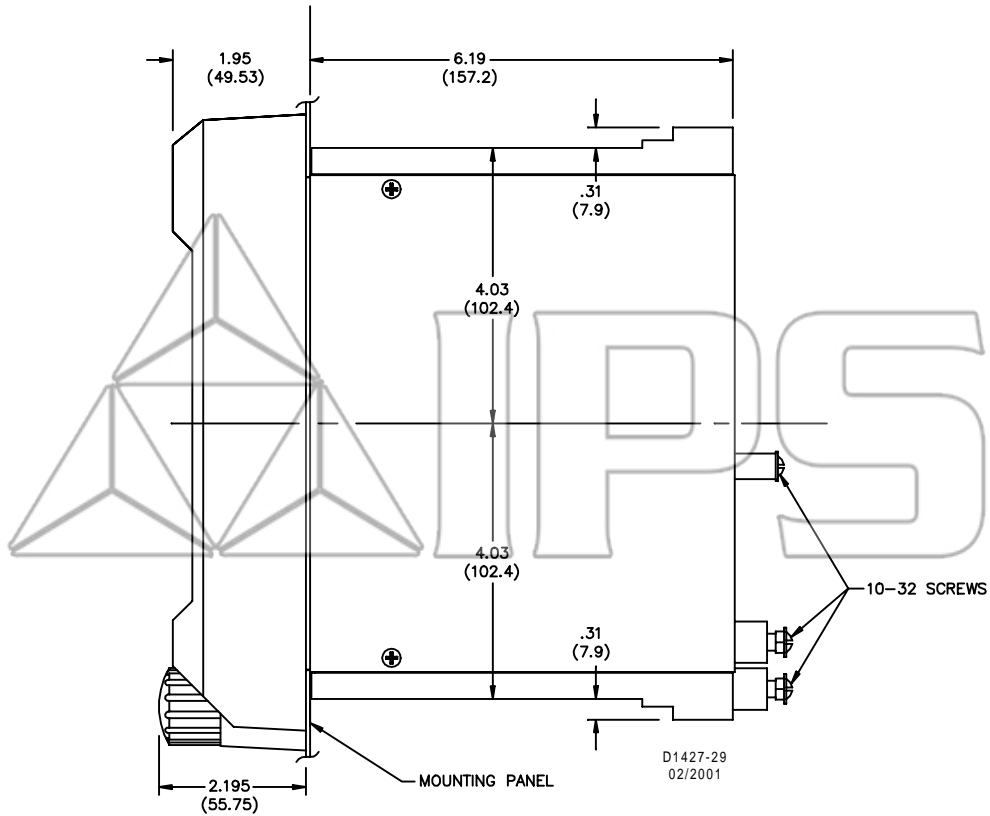

Figure 4-3. S1 Case, Single-Ended, Semi-Flush Mounting, Outline Dimensions, Side View

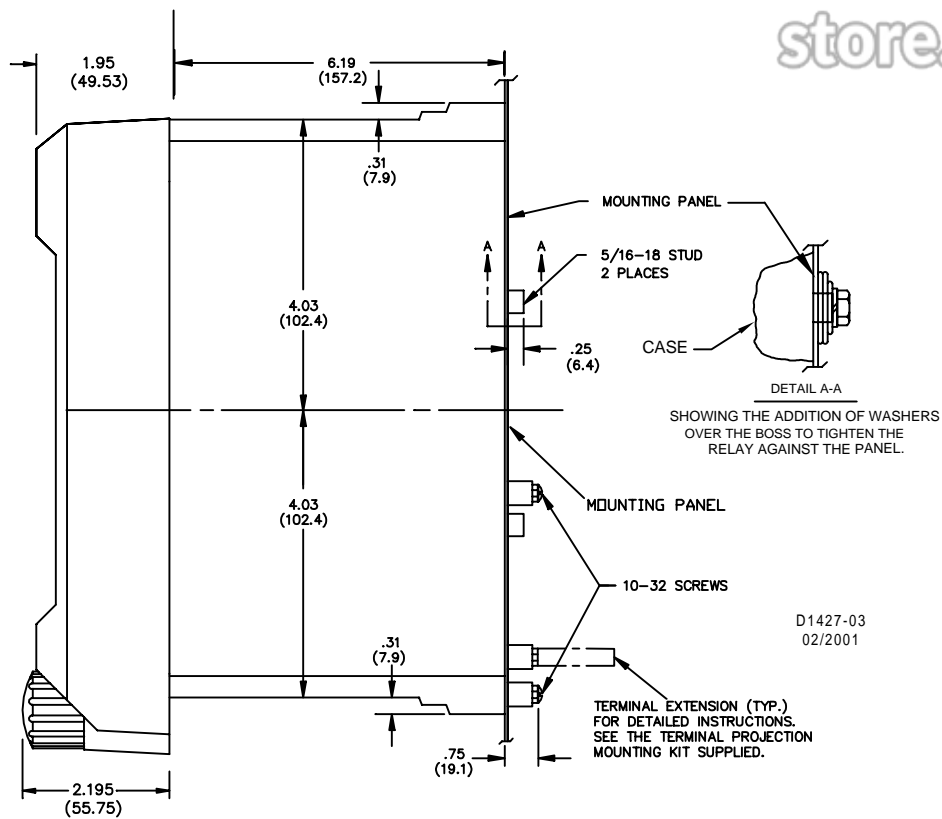

Figure 4-4. S1 Case, Single-Ended, Projection Mounting, Outline Dimensions, Side View

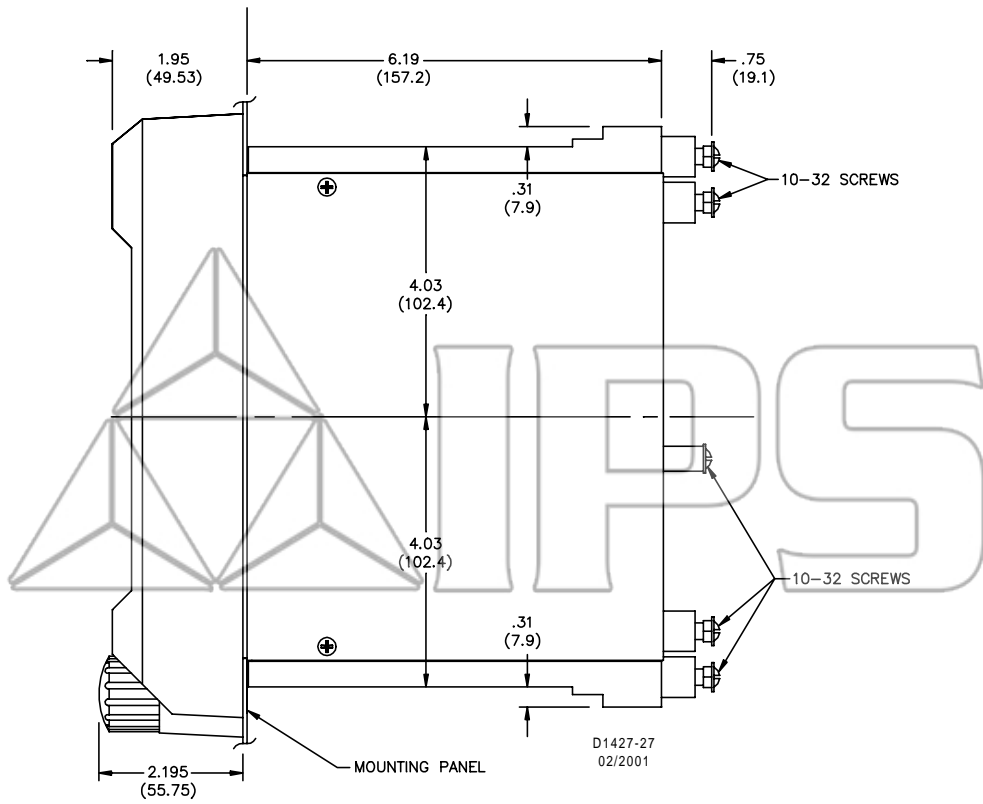

Figure 4-5. S1 Case, Double-Ended, Semi-Flush Mounting, Outline Dimensions, Side View

store.ips.us

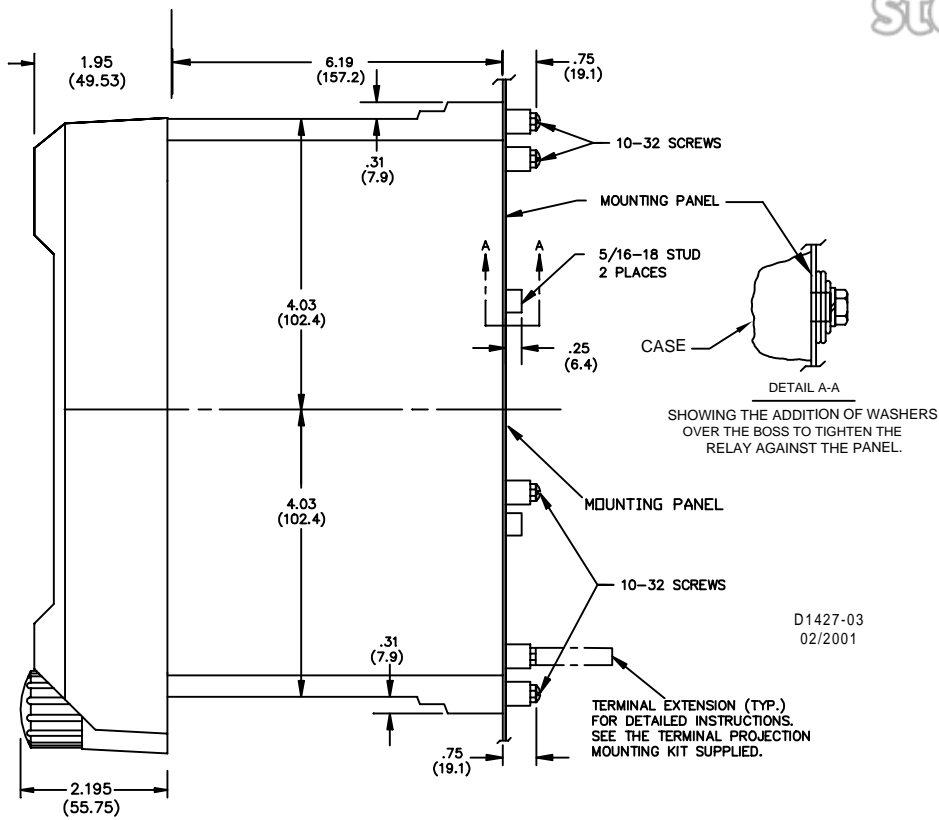

Figure 4-6. S1 Case, Double-Ended, Projection Mounting, Outline Dimensions, Side View

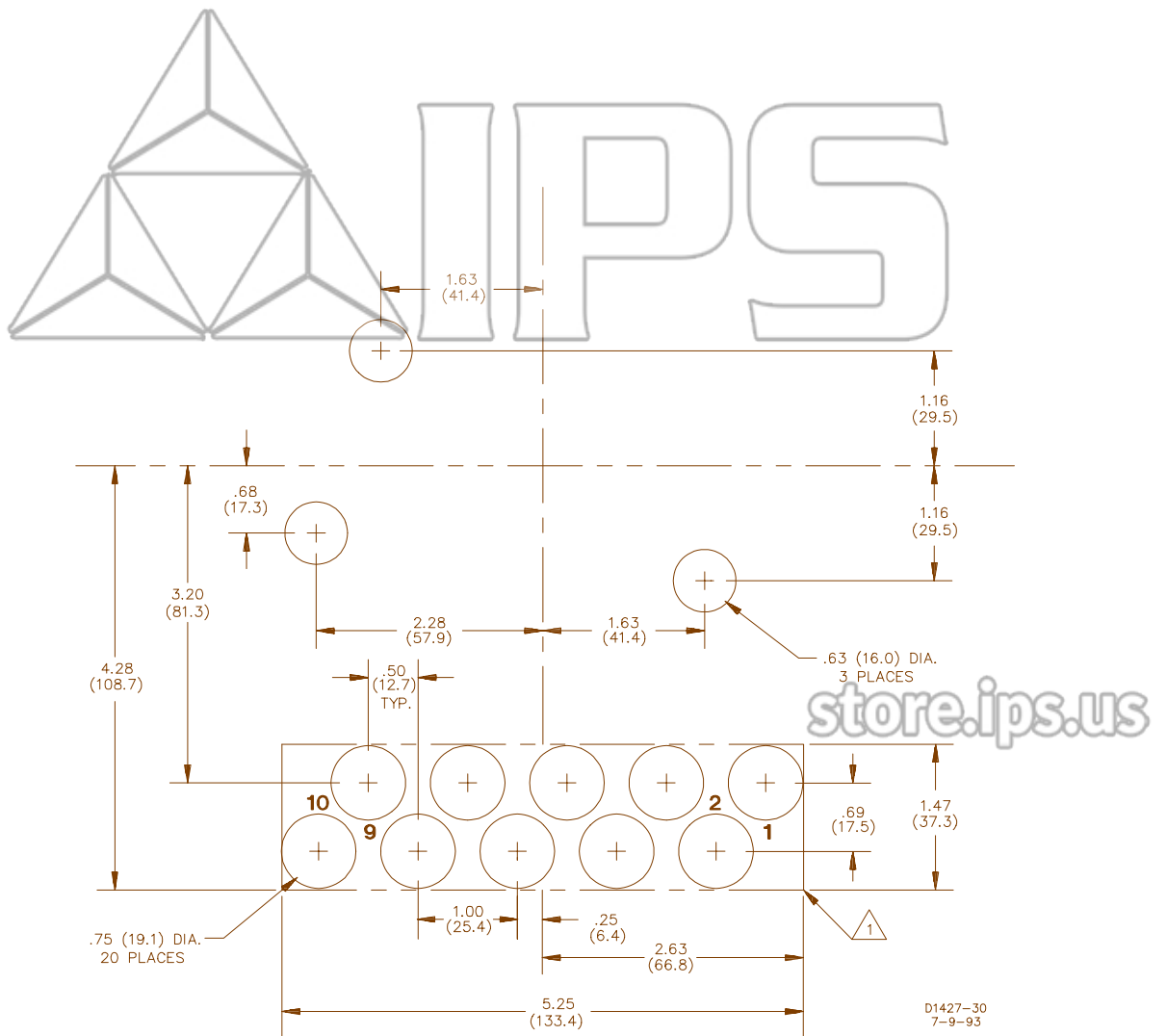

Figure 4-7. S1 Case, Single-Ended, Panel Drilling Diagram, Rear View



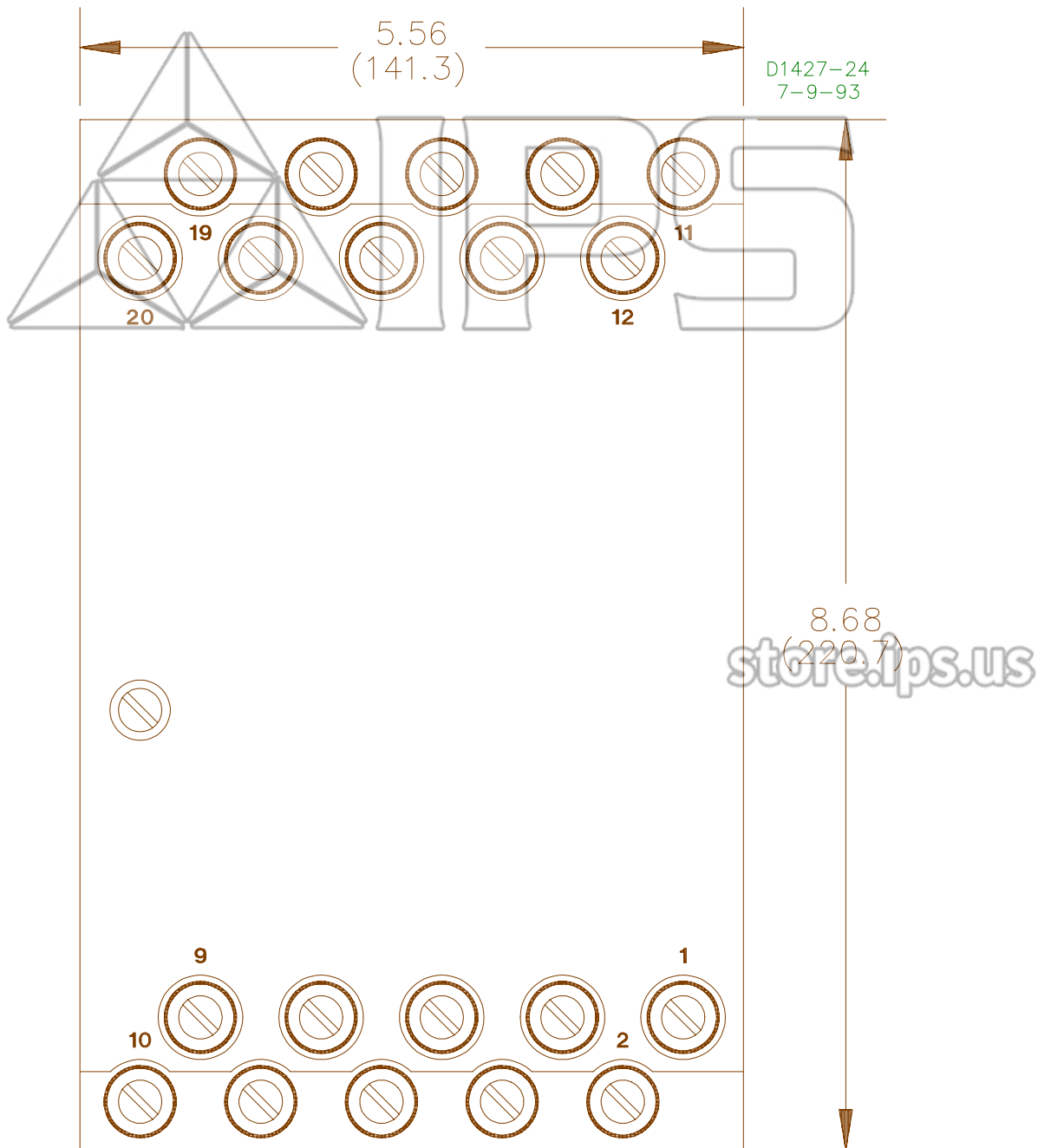

Figure 4-9. Semi-Flush Mounting, Outline Dimensions, Rear View

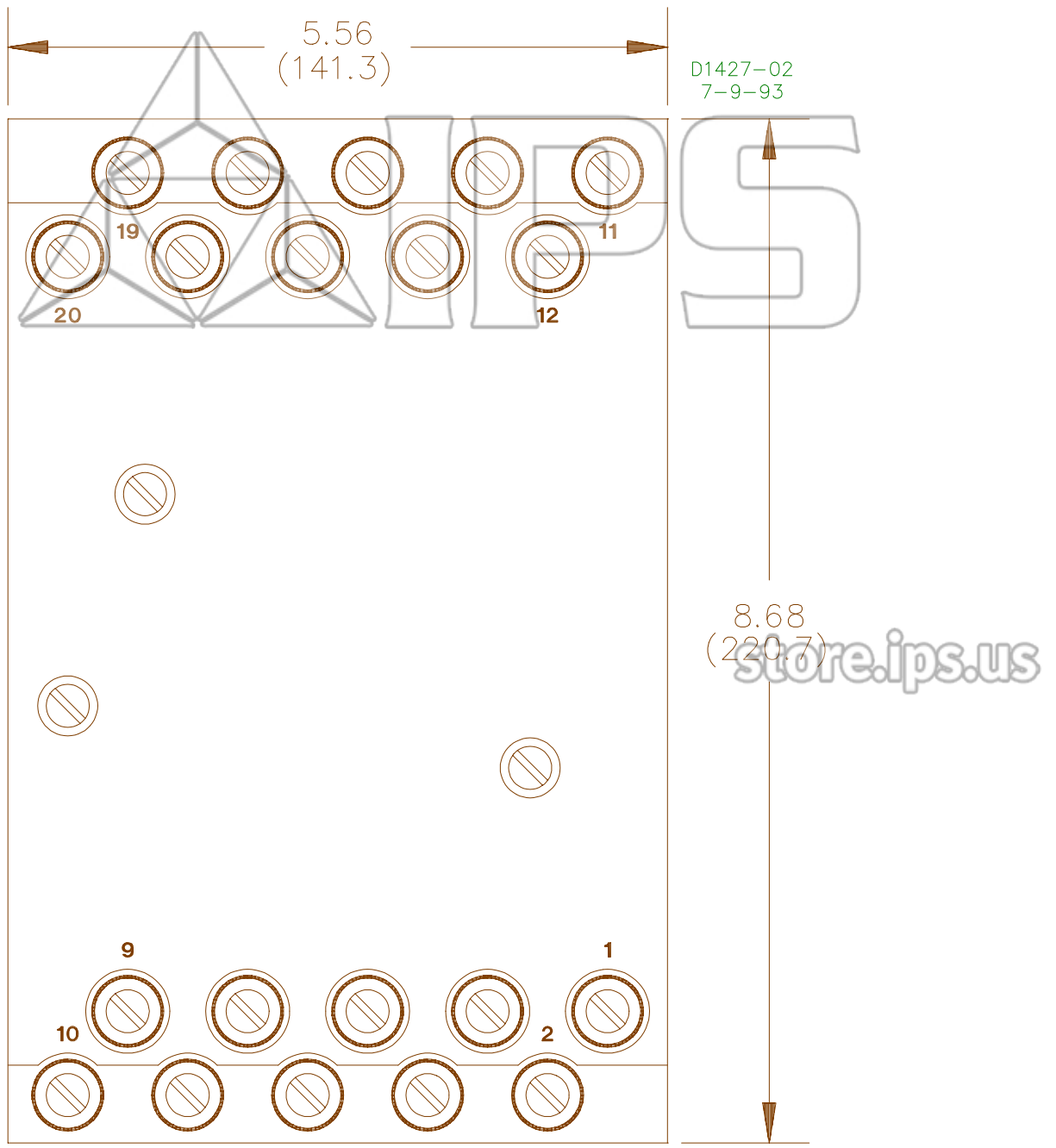

Figure 4-10. S1 Case, Projection Mounting, Outline Dimensions, Rear View

## CONNECTIONS

Incorrect wiring may result in damage to the relay. Be sure to check model and style number before connecting and energizing the particular relay. Typical external connections are shown in Figures 4-11 and 4-12. Typical internal connections are shown in Figure 4-13.

### NOTE

Be sure the relay case is hard-wired to earth ground with no smaller than 12 AWG copper wire attached to the ground terminal on the rear of the relay case. When the relay is configured in a system with other protective devices, it is recommended to use a separate lead to the ground bus from each relay.

Except as noted above, connections should be made with minimum wire size of 14 AWG.

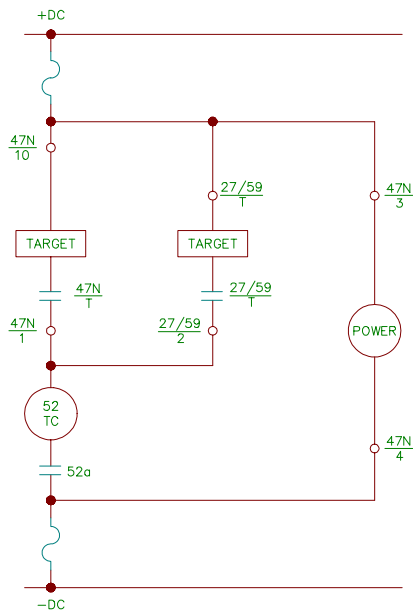

### LEGEND:

47N VOLTAGE PHASE SEQUENCE  
 27/59 UNDER/OVERVOLTAGE  
 52a BREAKER AUXILIARY CONTACTS  
 52 TC BREAKER TRIP COIL  
 T TIMED

store.ips.us

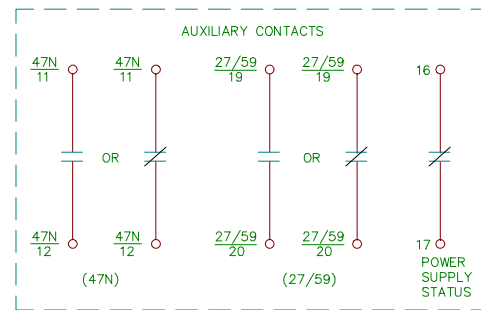

D1721-02  
 07-29-98

CONTROL CIRCUIT

Figure 4-11. Control Circuit Diagram

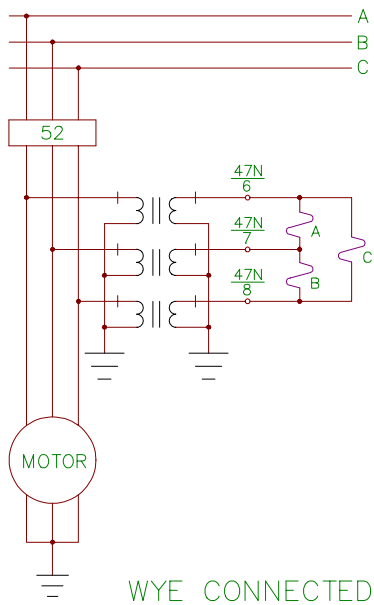

D1721-01  
07-29-98

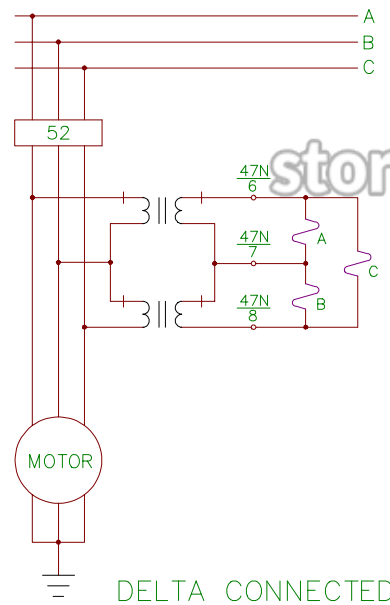

store.ips.us

Figure 4-12. Sensing Input Connections

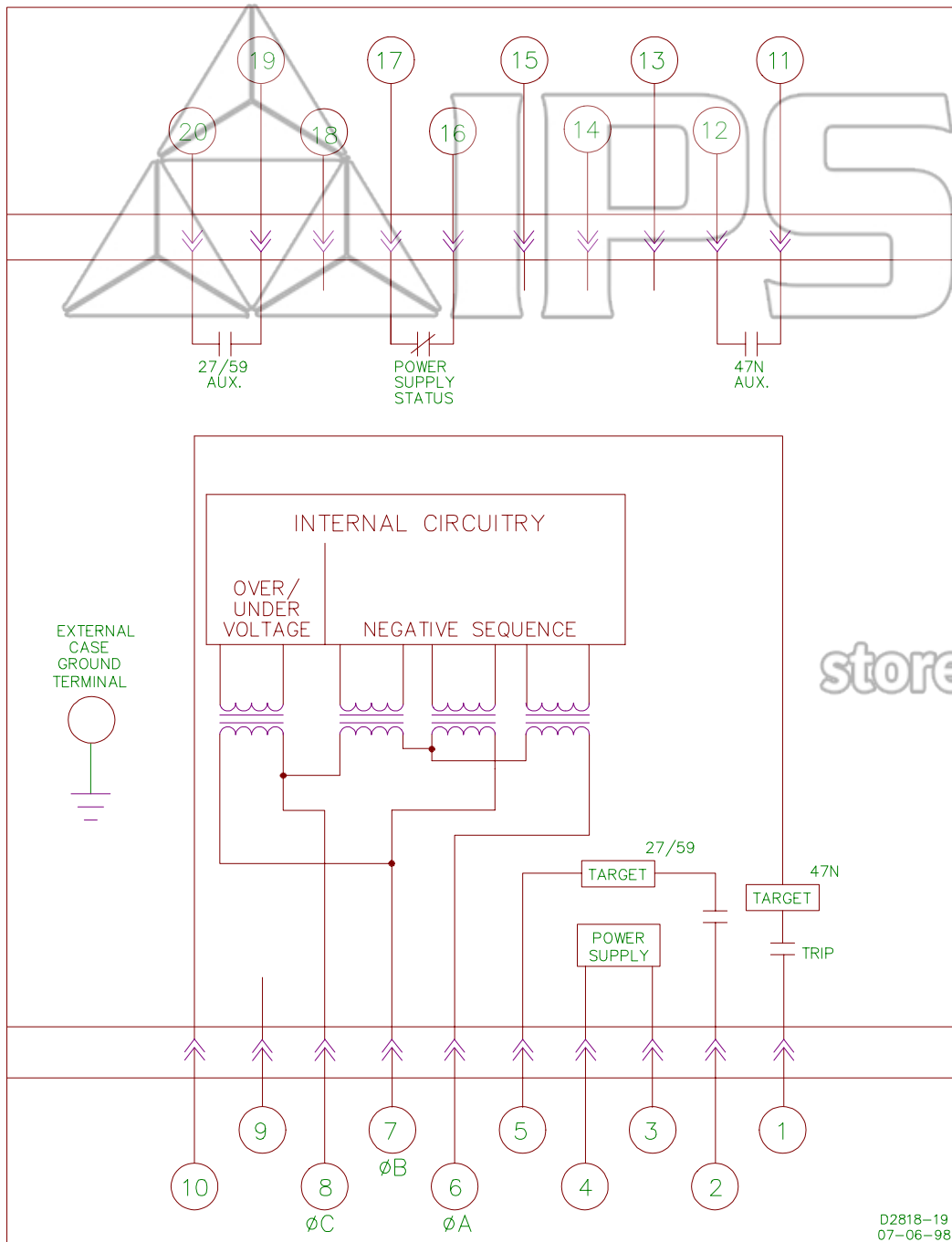

Figure 4-13. Typical Internal Connection Diagram with Optional Output Contacts, Normally Open

# SECTION 5 • TESTING

---

## GENERAL

The following procedures verify operation and calibration of the relay.

Results obtained from these procedures may not fall within specified tolerances. When evaluating results, consideration must be given to three prominent factors.

- The inherent error of the test equipment used.
- The inconsistent method of testing (i.e. Timing start signal).
- The tolerance level of external components used in the test setup.

---

## OPERATIONAL TEST PROCEDURES

### Negative Sequence Voltage Pickup and Dropout

To fully test the designed-in accuracy of the BE1-47N relay requires a simultaneous test of the three phases. Such a comprehensive test involves careful monitoring of all phase voltages and phase angles, and the calculation of the negative sequence voltages values. However, it is possible to obtain confirmation of the essential integrity of the relay without resorting to methods that are more suited to a laboratory.

Accordingly, the following single-phase verification test is offered as an adequate test that is easy to setup and execute. This will confirm relay accuracy and calibration.

STEP 1. Adjust the NEGATIVE SEQUENCE PICKUP setting to the "K" position (20%).

STEP 2. Short or jumper input terminal #7 (phase B) to #8 (phase C) (Figure 5-1).

STEP 3. Apply an input voltage at nominal frequency from terminal #6 (phase A) to #7 (phases B and C) based on the sensing input ranges listed below.

Sensing Input Range	Voltage Input
3 - 120V/60 Hertz	41.57 Vac +2.08 Vac, 60 Hertz
4 - 100V/50 Hertz	34.64 Vac +1.73 Vac, 50 Hertz
5 - 208V/60 Hertz	72.05 Vac +3.60 Vac, 60 Hertz
6 - 173V/50 Hertz	59.93 Vac +3.00 Vac, 50 Hertz

RESULT: Negative Sequence Voltage Pickup LED should turn ON at this point.

STEP 4. Vary the input to verify the setting.

STEP 5. Lower the input voltage until the pickup LED turns OFF and record the input voltage.

RESULT: Dropout should be within 2% of the pickup value (i.e. input voltage at time of pickup, LED ON).

Further pickup settings may be verified at this time. The following formulas determine the input voltages, based on sensing range, that will cause the pickup LED to turn ON.

$$V_2 = \frac{1}{3} [V_A + \alpha^2 V_B + \alpha V_C] \text{ where } \alpha = 1 \angle 120^\circ$$

Equation 1.

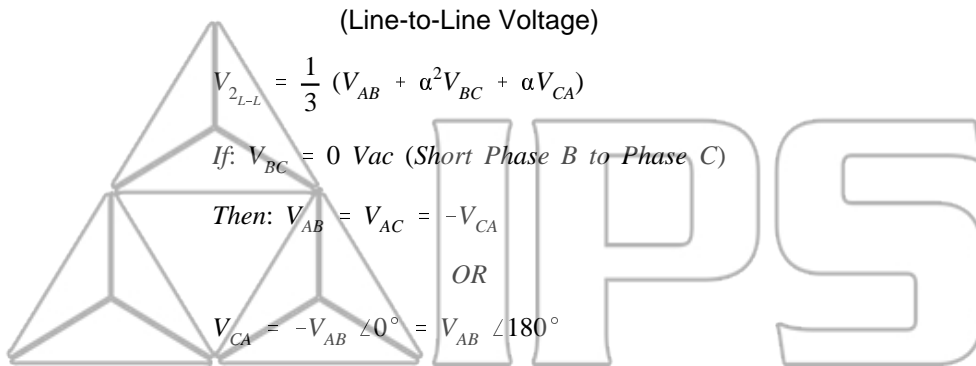

Substituting into Equation 1:

$$\begin{aligned}
 V_{2_{L-L}} &= \frac{1}{3} [V_{AB} + \alpha^2(0) + \alpha(V_{AB} \angle 180^\circ)] \\
 &= \frac{1}{3} V_{AB} [(1 \angle 0^\circ) + (1 \angle 120^\circ \times 1 \angle 180^\circ)] \\
 &= \frac{1}{3} V_{AB} [(1 \angle 0^\circ) + (1 \angle 300^\circ)] \\
 &= \frac{1}{3} [V_{AB}(\sqrt{3} \angle -30^\circ)] \\
 \text{or } &= \frac{V_{AB}}{\sqrt{3}} \angle -30^\circ
 \end{aligned}$$

store.ips.us

Equation 2.

$$V_{2_{PU}} = \frac{V_{2_{L-L}}}{V_N} = \frac{V_{AB} \angle -30^\circ}{V_N \sqrt{3}}$$

Solving for  $V_{AB}$ :

$$\begin{aligned}
 \text{Magnitude } V_{AB} &= V_{2_{PU}} \times \sqrt{3} \times V_N \\
 \text{where } V_N &= 120V \text{ for Sensing Input Range 3} \\
 &= 208V \text{ for Sensing Input Range 5}
 \end{aligned}$$

Example:

$$\begin{aligned}
 20\% V_2 &= 0.2 \text{ per unit } V_2 \text{ (with Phase B shorted to Phase C)} \\
 \text{For } 120V \text{ Nominal } V_N &= 120 \\
 V_{AB} &= (0.2) (\sqrt{3}) (120) \\
 V_{AB} &= 41.569 \text{ Vac when Phase Input B is shorted to C}
 \end{aligned}$$

STEP 6. Test the other phases by repeating the previous steps while shorting different phase-pairs.

### **Overvoltage Pickup and Dropout**

STEP 1. Adjust the OVERVOLTAGE PICKUP setting to the "E" position (10%).

STEP 2. Apply 1.10 times the nominal input value (110%) across terminals #7 (phase B) and #8 (phase C).

RESULT: Overvoltage pickup LED should turn ON.

STEP 3. Vary the input to confirm the value.

STEP 4. Lower the input until the pickup LED turns OFF and record the input value.

RESULT: Dropout should be within 2.0% of the pickup value (i.e. input voltage at time of pickup, LED ON).

### **Undervoltage Pickup and Dropout**

STEP 1. Adjust the UNDERVOLTAGE PICKUP setting to the "E" position (10%).

STEP 2. Apply 0.90 times the nominal input value (90%) from terminal #7 (phase B) to #8 (phase C).

RESULT: Undervoltage pickup LED should turn ON.

STEP 3. Vary the input to confirm the value.

STEP 4. Raise the input until the pickup LED turns OFF and record the input value.

RESULT: Dropout should be within 2.0% of the pickup value (i.e. input voltage at time of pickup, LED ON).

---

## **VERIFICATION TESTS**

### **Definite Time Verification**

The definite time circuitry for the negative sequence voltage function (47N) as well as the overvoltage (59) and the undervoltage (27) functions of the relay operate similarly and can be tested using the same philosophy. In order to reduce the amount of redundant procedural steps, only the overvoltage function (59) will be addressed.

STEP 1. Connect the test setup as shown in Figure 5-2, Test Circuit Diagram.

STEP 2. Adjust the OVERVOLTAGE TIME DELAY to 33.

STEP 3. Adjust the OVERVOLTAGE PICKUP setting to the "A" position (2%).

STEP 4. Adjust the voltage source to 1.20 times the nominal input value (120%) from terminal #7 (phase B) to #8 (phase C).

STEP 5. Close switch S1 to initiate timer. (Note: PICKUP LED turns ON.) Timer should time out at 3.3 seconds  $\pm 5\%$ .

### **Inverse Time Verification**

Due to the similarities in inverse timing for the functions of this relay, only the negative sequence function is addressed. The remaining functions can be verified using the same test philosophy.

STEP 1. Connect the test setup as indicated in Figure 5-1.

STEP 2. Make the following relay front panel adjustments:

Negative Sequence Pickup - "B" (4%) position

Negative Sequence Time Delay - 10

STEP 3. Short or jumper case terminal #7 (phase B) to #8 (phase C).

STEP 4. Apply the following input voltage from terminal #6 (phase A) to #7 (phase B and C) according to

the following table.

**Sensing Input Range**

E3 - 120V/60 Hertz  
E4 - 100V/50 Hertz  
E5 - 208V/60 Hertz  
E6 - 173V/50 Hertz

**Input Voltage**

16.628 +0.17 Vac, 60 Hertz  
13.856 +0.14 Vac, 50 Hertz  
28.80 +0.29 Vac, 60 Hertz  
24.00 +0.24 Vac, 50 Hertz

NOTE: Input voltage values are at 2 times actual pickup value.

STEP 5. Measure and record the interval from initiate to contact closure at case terminals #1 and #10.

RESULT: 47N Inverse Time should be 5.96 +0.298 seconds.

Further points on the inverse time curves may be verified using the same philosophy. Input voltage values for pickup may be obtained using the formulas mentioned previously.

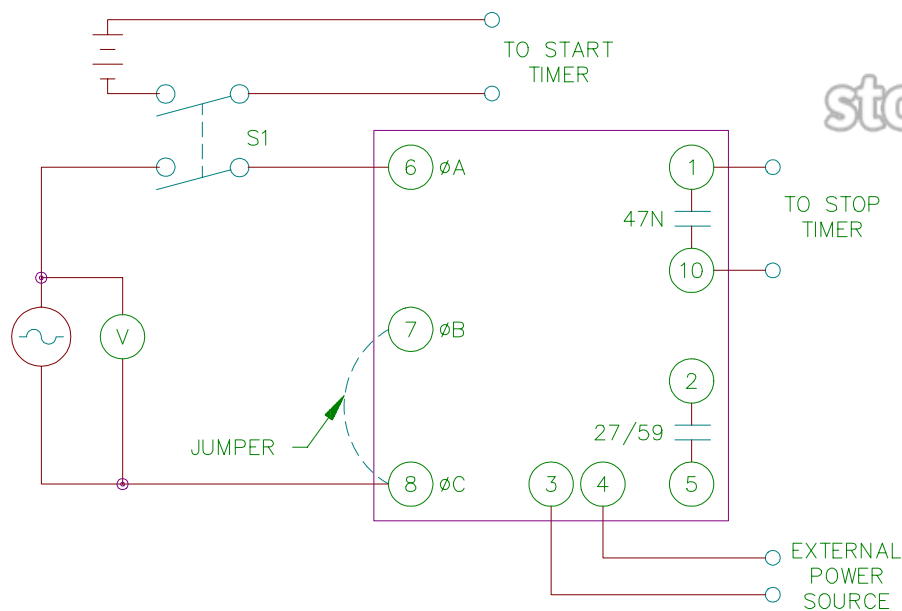

Figure 5-1. Test Circuit Diagram (47N)

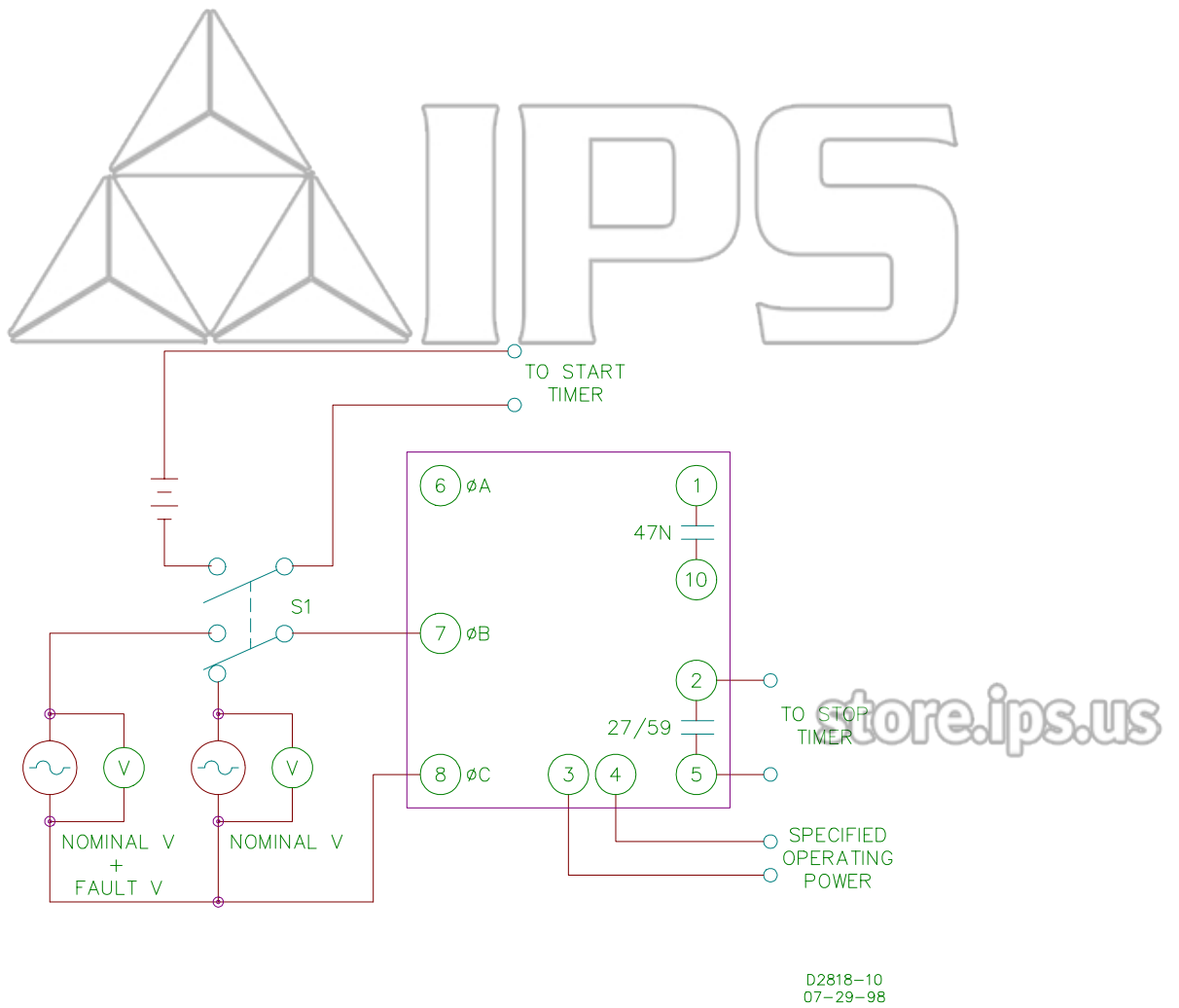

Figure 5-2. Test Circuit Diagram (27, 59)

# SECTION 6 • MAINTENANCE

---

## GENERAL

Basler relays are static devices which require no preventive maintenance other than a periodic operational check. If the relay fails to function properly, contact the Customer Service Department of the Power Systems Group, Basler Electric, for a return authorization number prior to shipping the relay.

Since most components are on conformally coated PC boards, in-house replacement of individual components may be difficult and should not be attempted unless appropriate equipment and qualified personnel are available. Accordingly, it is recommended that the relay be returned to the factory for repair and recalibration. When returning the relay to the factory ship the entire relay cradle assembly, preferably in its case.

---

## IN-HOUSE REPAIR

Replacement parts can be purchased locally. The quality of replacement parts must be at least equal to that of the original components.

### CAUTION

Substitution of printed circuit boards or individual components does not necessarily mean the relay will operate properly. Always test the relay before placing it in operation.

Where special components are involved, Basler Electric part numbers may be obtained from the number stamped on the component or assembly, the schematic, or the parts list. These parts may be ordered directly from Basler Electric. Complete boards or assemblies may be ordered by supplying the following information.

1. Model and style number
2. Relay serial number
3. Board or assembly
  - a) part number
  - b) serial number
  - c) revision letter
4. The name of the board or assembly

---

## STORAGE

This protective relay contains aluminum electrolytic capacitors which generally have a life expectancy in excess of 10 years at storage temperatures less than 40°C. Typically, the life expectancy of the capacitor is cut in half for every 10°C rise in temperature. Storage life can be extended if, at 1 year intervals, power is applied to the relay for a period of thirty minutes.

# SECTION 7 • MANUAL CHANGE INFORMATION

## CHANGES

This section contains information concerning the previous editions of the manual. The substantive changes to date are summarized in Table 7-1.

Table 7-1. Changes

Revision	Change	ECA/Date
D	<p>Pages 1-3 and 4-1: The 0.2 A minimum current required for "current operated" targets is not limited to dc, as was formerly stated. (Ac serves equally well.)</p> <p>Page 1-3: Negative sequence voltage timing accuracy restated for clarification.</p> <p>Page 3-5: Figure 3-3 replotted to improve representation.</p> <p>Pages 4-2 thru 4-5: Operational tests and verification tests revised for clarification.</p> <p>Page 4-5, Step 5: Result corrected.</p> <p>Page 4-7: Projection mounting drawings corrected.</p> <p>Section 6 added.</p>	11288/11-22-89
E	<p>Deleted reference to Service Manual 9 1704 00 620. Added Phase Rotation Sensitivity to Section 1. Updated the Dielectric Test information. Changed Input Voltage Range and Burden Data in Power supply table in <i>Specifications</i>. Also added RFI and UL information. Corrected Style Chart by changing power supply type T from "230 Vac" to "240 Vac" and deleting from Target Option N) None. Added new power supply information to Section 3 in <i>Power Supply</i> paragraph starting with "Basler Electric enhanced the power supply design...". Added new dimension figures to include all options available (S1 Single-Ended and Double-Ended, and both mounting positions). Separated old Section 4 into two sections, "Section 4 Installation" and "Section 5 Testing." Changed the format of the manual.</p>	16905/08-98
F	<p>Replaced the S1 Case drawings in section 4 with the new S1 Case drawings. Replaced the old style chart in Section 1 with the new style chart.</p>	12267/02-09-01