

INSTRUCTION MANUAL

FOR

TIME OVERCURRENT RELAY

BE1-51

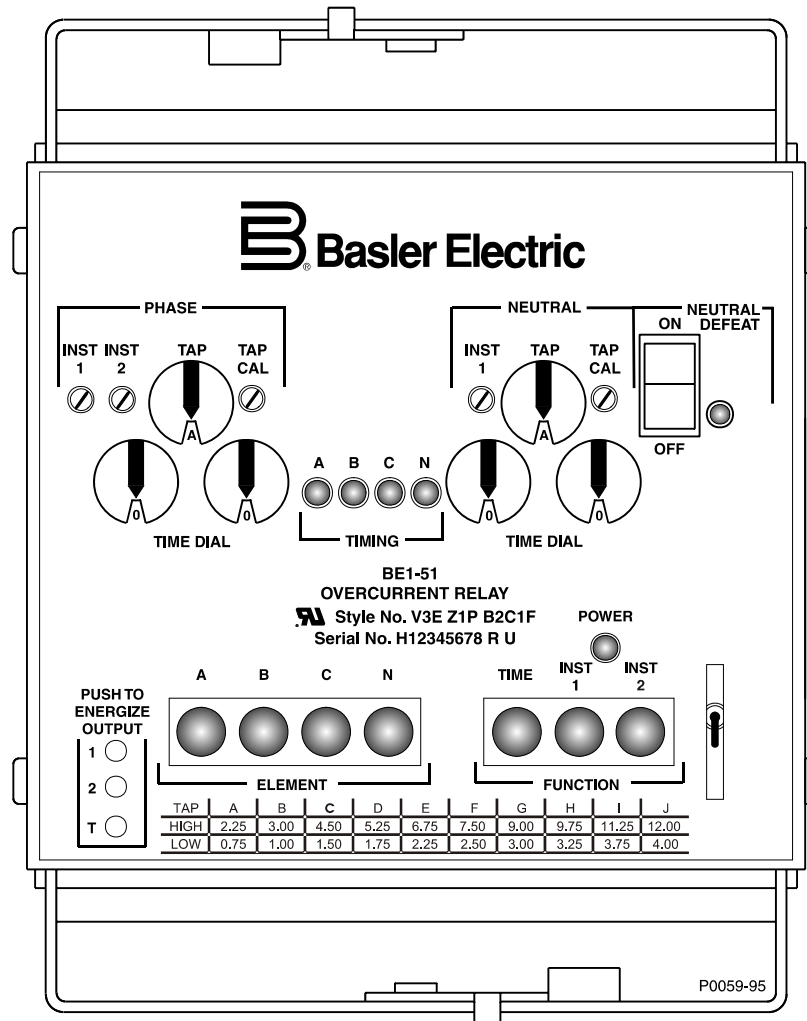

INTRODUCTION

This instruction manual provides information about the operation and installation of the BE1-51 Time Overcurrent Relay. To accomplish this, the following information is provided:

- General Information and Specifications
- Controls and Indicators
- Functional Description
- Installation
- Tests and Adjustments

WARNING!

To avoid personal injury or equipment damage, only qualified personnel should perform the procedures in this manual.

NOTE

Be sure that the BE1-51 is hard-wired to earth ground with no smaller than 12 AWG copper wire attached to the ground terminal on the rear of the unit case. When the BE1-51 is configured in a system with other devices, it is recommended to use a separate lead to the ground bus from each unit.

First Printing: July 1992

Printed in USA

Copyright © 1992-2010 Basler Electric, Highland Illinois 62249 USA

All Rights Reserved

July 2010

CONFIDENTIAL INFORMATION

of Basler Electric, Highland Illinois, USA. It is loaned for confidential use, subject to return on request, and with the mutual understanding that it will not be used in any manner detrimental to the interest of Basler Electric.

It is not the intention of this manual to cover all details and variations in equipment, nor does this manual provide data for every possible contingency regarding installation or operation. The availability and design of all features and options are subject to modification without notice. Should further information be required, contact Basler Electric.

**BASLER ELECTRIC
ROUTE 143, BOX 269
HIGHLAND IL 62249 USA**

<http://www.basler.com>, info@basler.com

PHONE +1 618.654.2341

FAX +1 618.654.2351

REVISION HISTORY

The following information provides a historical summary of the changes made to the BE1-51 instruction manual (9137200997). Revisions are listed in reverse chronological order.

Manual Revision and Date	Change
E, 07/10	<ul style="list-style-type: none"> • Replaced cover drawing and Figure 2-1. (New front panel switches and graphics.)
D, 08/07	<ul style="list-style-type: none"> • Updated <i>Output Contacts</i> ratings in Section 1. • Moved content of Section 6, <i>Maintenance</i> to Section 4. • Updated front panel illustrations to show laser graphics. • Moved content of Section 7, <i>Manual Change Information</i> to manual introduction. • Added manual part number and revision to all footers. • Updated cover drawings. • Moved <i>Time Overcurrent Characteristic Curves</i> from Section 1 to new Appendix A. • Updated power supply burden data in Section 1. • Updated Target Indicator description in Section 3.
C, 01/98	<ul style="list-style-type: none"> • Changed paragraph styles to new manual design. • Added Note 3 to Figure 1-1. • Corrected inductive output specification from 0.1 to 0.3 A. • Changed TOC specification. • Added instantaneous response time with graph 1-1. • Deleted specification reference to field selectable switch in Type S power supply. • Corrected weight in kilograms for all case styles. • Replaced Figure 1-49 with correct curve. • Corrected Figure 1-51. • Added multiturn potentiometer description to controls in Table 2-1. • Corrected Range 9 entries in Table 2-2. • Changed “Element D” in Table 2-4 to “Element N”. • Deleted Figure 3-1. • Revised the power supply functional description to accommodate new wide range power supplies. • Corrected Figures 4-2, 4-3, and 4-4. • Deleted Figure 4-5.
B, 09/93	<ul style="list-style-type: none"> • Added Figures 4-4 and 4-6 through 4-9. • Restructured Section 5, <i>Operational Test</i>. • Corrected minor typographical errors.
A, 02/93	<ul style="list-style-type: none"> • Added characteristic curves for integrating algorithm, Figures 1-39 through 1-70. • Changed Figure 1-2. • Corrected minor discrepancies.
—, 07/92	<ul style="list-style-type: none"> • Initial release

This page intentionally left blank.

CONTENTS

SECTION 1 • GENERAL INFORMATION	1-1
SECTION 2 • CONTROLS AND INDICATORS.....	2-1
SECTION 3 • FUNCTIONAL DESCRIPTION	3-1
SECTION 4 • INSTALLATION	4-1
SECTION 5 • TESTS AND ADJUSTMENTS.....	5-1
APPENDIX A • TIME OVERCURRENT CHARACTERISTIC CURVES.....	A-1

This page intentionally left blank.

SECTION 1 • GENERAL INFORMATION

TABLE OF CONTENTS

SECTION 1 • GENERAL INFORMATION.....	1-1
DESCRIPTION.....	1-1
STANDARD FEATURES	1-1
Time Overcurrent Functions.....	1-1
Non-Integrating Timing.....	1-2
Integrating Timing.....	1-2
Built-In Test	1-2
OPTIONS	1-2
Timing.....	1-2
Neutral Defeat	1-2
Sensing Input Type	1-2
Sensing Input Range.....	1-2
Power Supply	1-3
Targets	1-3
Outputs	1-3
Instantaneous Outputs	1-3
Packaging.....	1-3
MODEL AND STYLE NUMBER DESCRIPTION.....	1-3
SPECIFICATIONS	1-5
Sensing Input Burden.....	1-5
Sensing Input Rating.....	1-5
Time Overcurrent Pickup Selection Range.....	1-5
Time Overcurrent Measuring Accuracy.....	1-5
Time Overcurrent Dropout Ratio	1-5
Instantaneous Overcurrent Pickup Range	1-5
Instantaneous Overcurrent Measuring Accuracy.....	1-5
Instantaneous Overcurrent Dropout Ratio	1-5
Instantaneous Response.....	1-5
Time Delay Accuracy	1-6
Output Circuits.....	1-6
Target Indicators	1-6
Power Supply	1-6
Radio Frequency Interference (RFI)	1-6
Isolation	1-6
Surge Withstand Capability.....	1-7
UL Recognized.....	1-7
GOST-R.....	1-7
Operating Temperature.....	1-7
Storage Temperature	1-7
Shock.....	1-7
Vibration	1-7
Weight	1-7
Case Size	1-7

Figures

Figure 1-1. Style Number Identification Chart	1-4
Figure 1-2. Typical Instantaneous Response Time.....	1-5

Tables

Table 1-1. Power Supply Specifications.....	1-6
---------------------------------------------	-----

This page intentionally left blank.

SECTION 1 • GENERAL INFORMATION

DESCRIPTION

BE1-51 Time Overcurrent Relays are microprocessor-based devices that monitor the magnitude of single-phase, two-phase-and-neutral, or three-phase-and-neutral ac current to provide accurate time overcurrent and instantaneous overcurrent protection for 50 hertz or 60 hertz power systems.

STANDARD FEATURES

Time Overcurrent Functions

Time overcurrent elements pick up over a range of 0.1 to 0.8 amperes, 0.3 to 2.4 amperes, 0.5 to 4.0 amperes, 1.5 to 12.0 amperes, 0.1 to 2.4 amperes, or 0.5 to 12.0 amperes and provide an adjustable time delay that is proportional to the overcurrent. Time delay is initiated when the sensed current exceeds the pickup point. When the current drops below the pickup point, the timing circuit is reset immediately. At reset, the output contacts, if operated, are restored to normal.

Adjustment of the overcurrent pickup point is provided by controls on the relay front panel. Time delay is a function of the characteristic curve that has been selected. Time delay is settable from 00 to 99 on the **TIME DIAL** thumbwheel switch located on the front panel. Curve type is selected either as an option or, in some models, is switch selectable.

Sixty-nine characteristic curves and three timing options are available. They are:

Characteristic curves:

- Seven inverse time
- Nine I^2t
- Seven inverse time with extended timing range
- Nine I^2t with extended timing range
- Five British Standard 142 (E curves)
- Seven integrating inverse time
- Nine integrating I^2t
- Seven integrating inverse time with extended timing range
- Nine integrating I^2t with extended timing range

Timing option Z1 (switch selectable - 16 position) B and C curves:

- Seven inverse time
- Nine I^2t

Timing option Z1 with option 2-D or 2-E (switch selectable - 16 position) B and C curves:

- Seven inverse time with extended timing range
- Nine I^2t with extended timing range

Timing option Z2 (switch selectable - 16 position) B and E (British Standard 142) curves:

- Seven inverse time
- One I^2t
- Five British Standard (BS) 142 (E curves)

Timing option Z2 with option 2-D or 2-E (switch selectable - 16 position) B and E (BS142) curves:

- Seven inverse time with extended timing range
- One I^2t with extended timing range
- Five British Standard 142 (E curves)

Timing option Z3 (switch selectable - 16 position) integrating B and C curves:

- Seven integrating inverse time
- Nine integrating I^2t

Timing option Z3 with option 2-D or 2-E (switch selectable - 16 position) integrating extended B and C curves:

- Seven integrating inverse time with extended timing range
- Nine integrating I^2t with extended timing range

Characteristic curves are shown by the graphs in Appendix A, *Time Overcurrent Characteristic Curves*. Note that each graph (i.e. function) consists of a set of representative curves. Each curve (as well as any between-curve interpolation) is selectable by the front panel **TIME DIAL** using a two-digit destination from 00 to 99. Because of space limitations, each graph shows only 14 of the 100 possible selections.

Non-Integrating Timing

Timing options Z1 and Z2 and the characteristic curves available with those options use non-integrating timing. Non-integrating timing is accomplished by timing at a gate that is not solely dependent on the magnitude of the applied multiple of pickup current. The time-out value is calculated based on the type of time curve characteristic selected, time dial setting, and the magnitude of the applied multiple of pickup current. The time-out value is continuously updated during the timing cycle. When pickup is exceeded, a timer is initiated. When the timer elapsed time exceeds the calculated time-out value, a time trip output signal is generated.

This type of non-integrating time delay characteristic exhibits a dynamic characteristic that is immediately responsive to changes of the applied multiple of pickup current.

Integrating Timing

Timing option Z3 and the characteristic curves available for that option uses integrating timing. Integrating timing is accomplished by summing time increments that are based on the magnitude of the applied multiple of pickup current, the time curve characteristic selected, and the time dial value. These time increments are summed until a predetermined value is exceeded, then a time trip output signal is generated.

This type of integrating time delay characteristic simulates the operating characteristics of an electromechanical overcurrent relay.

Built-In Test

A built-in test (BIT) switch mounted on the Logic Board provides diagnostic troubleshooting and calibration.

OPTIONS

Timing

An extended timing option multiplies by approximately 5.7, the standard time delays. The resulting curves are shown following the standard curves in Appendix A - e.g., Figure A-1 is timing type B1 and Figure A-2 is the timing type B1 with extended timing range.

When timing option Z1, Z2, or Z3 is specified, a printed circuit board mounted selector switch allows a choice of up to sixteen different time overcurrent functions. Timing option Z1 or Z3 may be further specified as standard or extended time, depending upon option 2 selection.

Neutral Defeat

When neutral defeat is specified, a front panel switch allows neutral current sensing to be disabled. This function permits the user to energize desired circuits and not trip because of imbalanced current in the neutral circuit. After the circuits are balanced, the neutral defeat function can be switched off and neutral current sensing protection is provided.

Sensing Input Type

When single-phase, two-phase-and-neutral, three-phase, or three-phase-and-neutral sensing has been specified, the front panel **TAP** selector and the front panel **TAP CAL** control set the pickup point for all phases. An independent front panel **TAP (NEUTRAL)** selector and front panel **CAL (NEUTRAL)** control set the neutral pickup point. In addition, for three-phase-and-neutral sensing units, one of the seven sensing input range combinations must be specified.

Sensing Input Range

For three-phase-and-neutral sensing units, input ranges are:

- 0.5 to 4.0 amperes (phase and neutral)
- 1.5 to 12 amperes (phase) and 0.5 to 4.0 amperes (neutral)

- 0.5 to 4 amperes (phase) and 1.5 to 12 amperes (neutral)
- 1.5 to 12 amperes (phase and neutral)
- 0.1 to 0.8 amperes (phase and neutral)
- 0.3 to 2.4 amperes (phase) and 0.1 to 0.8 amperes (neutral)
- 0.3 to 2.4 amperes (phase and neutral)

For all other units, two ranges are available. They are 0.5 to 12 amperes and 0.1 to 2.4 amperes.

Power Supply

Five power supply options are available. They are:

- 24 Vdc
- 48 Vdc
- 125 Vdc and 100/125 Vac
- 48 Vdc or 125 Vdc and 100/125 Vac
- 250 Vdc and 240 Vac

Targets

Single-phase relays have two function targets that indicate when the time delay or instantaneous element(s) have operated. On multiple phase relays, additional targets indicate which phase or neutral element(s) operated.

Function targets may be specified as either internally operated or current operated by a minimum of 0.2 amperes through the output trip circuit. When current operated, the output circuit must be limited to 30 amperes for 0.2 seconds, 7 amperes for 2 minutes, and 3 amperes continuously.

Outputs

Optional normally opened, normally closed, or SPDT auxiliary output contacts may be selected. Contacts actuate when the output relay is energized. Internally operated front panel mounted targets, and front panel targets operated by the dc current in the output circuit are available for the time overcurrent and instantaneous overcurrent functions. Optional front panel mounted **PUSH-TO-ENERGIZE-OUTPUT** pushbuttons allow direct actuation of each output relay for external circuit testing.

Instantaneous Outputs

One or two instantaneous overcurrent outputs are optionally available. Each is adjustable up to 40 times the time overcurrent pickup point. When the sensed current exceeds the instantaneous overcurrent pickup point, an output relay is energized. An independent front panel control (**INST 1** or **INST 2**) adjusts the pickup point for each optional output. If more than one phase is applied to the relay, the instantaneous pickup point will be the same for all phases. If neutral current is sensed, a front panel **INST 1 (NEUTRAL)** provides adjustment of the neutral pickup point. Instantaneous overcurrent elements are not voltage controlled.

Packaging

Each relay is mounted in a drawout cradle and enclosed in a standard utility style case with either semi-flush or projection mounting (depending upon case style selected). An available test plug (Basler Electric part number 10095) allows the relay to be tested in place without disturbing external control circuit wiring.

MODEL AND STYLE NUMBER DESCRIPTION

Electrical characteristics and operational features included in a particular style of the BE1-51 Time Overcurrent Relay are defined by a combination of letters and numbers that make up its style number. The model number, together with the style number, describes the options included in a specific device, and appears on the front panel, drawout cradle, and inside the case assembly. Upon receipt of a relay, be sure to check the style number against the requisition and the packing list to ensure that they agree.

Style Number Identification Chart (Figure 1-1) illustrates the manner in which the relay style number is determined. For example, if the style number were **H3E-Z1P-B2C1F**, the device would have the following characteristics:

- H - Three-Phase-and-Neutral sensing
- 3 - Sensing input range of 1.5 to 12.0 amperes for phase and 0.5 to 4.0 amperes for neutral
- E - Normally open outputs
- Z1 - Switch selectable time curves
- P - Operating power derived from 125 Vdc or 120 Vac
- B - Current operated targets
- 2 - Two instantaneous elements
- C - Push-to-energize outputs
- 1 - Normally open auxiliary timed output relay
- F - Semi-flush mounting

STYLE NUMBER IDENTIFICATION CHART

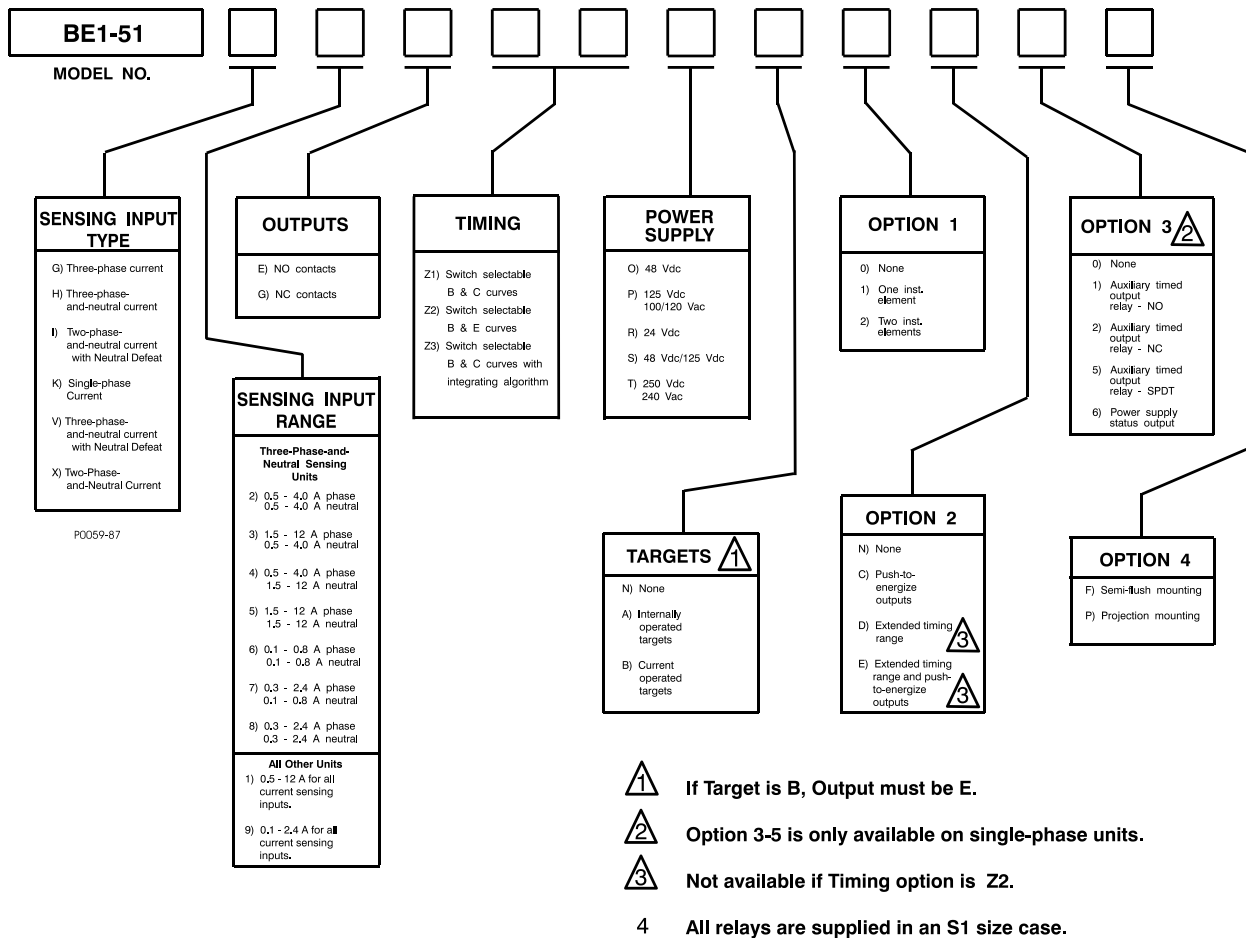

Figure 1-1. Style Number Identification Chart

SPECIFICATIONS

BE1-51 Time Overcurrent Relays electrical and physical specifications are as follows:

Sensing Input Burden

Less than 0.1 ohms per phase or neutral.

Sensing Input Rating

The maximum continuous rating is 20 A, 1 second current rating is 50X (times) the maximum tap current selected, or 500 A, whichever is less. For ratings other than those specified by the time curves, the rating is calculated as follows:

$$I = \frac{50 \times \text{tap or } 500 \text{ A (whichever is less)}}{\sqrt{T}}$$

where I = Maximum current

T = Time that current flows (in seconds)

Time Overcurrent Pickup Selection Range

Continuously adjustable over the current sensing input ranges specified in the Style Chart (Figure 1-1).

Time Overcurrent Measuring Accuracy

±2% of pickup setting.

When the **TAP CAL** control is fully CW, the actual pickup will be within ±5% of the front panel **TAP** selector setting.

Time Overcurrent Dropout Ratio

Better than 92% of pickup level.

Instantaneous Overcurrent Pickup Range

Continuously adjustable over the range of 1 to 40 times the time overcurrent pickup setting.

Instantaneous Overcurrent Measuring Accuracy

±2% of pickup setting.

Instantaneous Overcurrent Dropout Ratio

Better than 98% of pickup level.

Instantaneous Response

Figure 1-2 shows the typical response for the instantaneous pickup element.

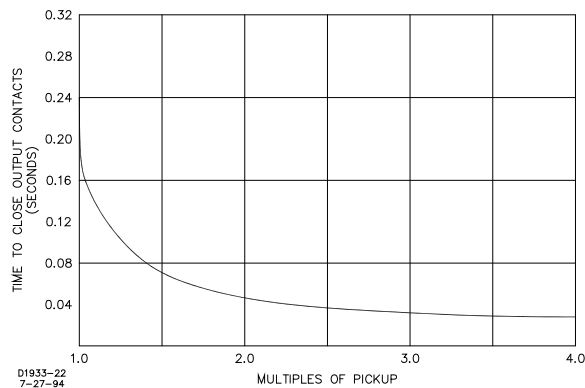

Figure 1-2. Typical Instantaneous Response Time

Time Delay Accuracy

±5% of the characteristic curve (Figures A-1 through A-37) for any combination of the front panel **TIME DIAL** setting and the front panel **TAP/TAP CAL** overcurrent pickup setting.

Repeatability is within ±2% of setting at 25°C.

Output Circuits

Resistive Ratings

120 Vac: Make, break, and carry 7 Aac continuously

250 Vdc: Make and carry 30 Adc for 0.2 s, carry 7 Adc continuously, and break 0.3 Adc

500 Vdc: Make and carry 15 Adc for 0.2 s, carry 7 Adc continuously, and break 0.3 Adc

Inductive Ratings

120 Vac, 125 Vdc, 250 Vdc: Break 0.3 A (L/R = 0.04)

Target Indicators

Function targets may be specified as either internally operated or current operated by a minimum of 0.2 amperes through the output trip circuit. When current operated, the output circuit must be limited to 30 amperes for 0.2 seconds, 7 amperes for 2 minutes, and 3 amperes continuously.

Power Supply

Power for the internal circuitry may be derived from a variety of ac or dc external power sources as indicated in Table 1-1.

Table 1-1. Power Supply Specifications

Type	Input Voltage		Burden at Nominal
	Nominal	Range	
O (mid range)	48 Vdc	24 to 150 Vdc	1.6 W
P (mid range)	125 Vdc 120 Vac	24 to 150 Vdc 90 to 132 Vac	1.9 W 8.9 VA
R (low range)	24 Vdc	12 to 32 Vdc *	1.7 W
S (mid range)	48 Vdc 125 Vdc	24 to 150 Vdc 24 to 150 Vdc	1.6 W 1.9 W
T (high range)	250 Vdc 240 Vac	68 to 280 Vdc 90 to 270 Vac	2.1 W 14.2 VA

* Type R power supply may require 14 Vdc to begin operation. Once operating, the voltage may be reduced to 12 Vdc.

Radio Frequency Interference (RFI)

Field-tested using a five-watt, hand-held transceiver operating at random frequencies centered around 144 MHz and 440 MHz, with the antenna located six inches from the relay in both horizontal and vertical planes.

Isolation

In accordance with IEC 255-5 and ANSI/IEEE C37.90, one-minute dielectric (high potential) tests as follows:

All circuits to ground: 2,121 Vdc

Input to output circuits: 1,500 Vac or 2,121 Vdc

Surge Withstand Capability

Qualified to ANSI/IEEE C37.90.1-1989, *Standard Surge Withstand Capability (SWC) Tests for Protective Relays and Relay Systems*.

UL Recognized

UL recognized per Standard 508, UL File No. E97033. Note: Output contacts are not UL recognized for voltages greater than 250 volts and input power supply voltages greater than 150 volts.

GOST-R

GOST-R certified per the relevant standards of Gosstandart of Russia.

Operating Temperature

The operating temperature range is from -40°C (-40°F) to $+70^{\circ}\text{C}$ ($+158^{\circ}\text{F}$).

Storage Temperature

The storage temperature range is from -65°C (-85°F) to $+100^{\circ}\text{C}$ ($+212^{\circ}\text{F}$).

Shock

In standard tests, the relay has withstood 15 g in each of three mutually perpendicular planes without structural damage or degradation of performance.

Vibration

In standard tests, the relay has withstood 2 g in each of three mutually perpendicular planes, swept over the range of 10 to 500 Hz for six sweeps, 15 minutes each sweep without structural damage or degradation of performance.

Weight

Single-Phase:	13.0 lbs. (5.90 kg)
Two-Phase and Neutral:	14.0 lbs. (6.35 kg)
Three-Phase:	14.0 lbs. (6.35 kg)
Three-Phase and Neutral:	14.4 lbs. (6.53 kg)

Case Size

S1 (Refer to Section 4 for case dimensions.)

This page intentionally left blank.

SECTION 2 • CONTROLS AND INDICATORS

TABLE OF CONTENTS

SECTION 2 • CONTROLS AND INDICATORS	2-1
INTRODUCTION.....	2-1

Figures

Figure 2-1. Location of Controls and Indicators	2-1
-------------------------------------------------------	-----

Tables

Table 2-1. Controls and Indicators	2-2
Table 2-2. Sensing Input Ranges	2-3
Table 2-3. Target Installation Configurations	2-4

This page intentionally left blank.

SECTION 2 • CONTROLS AND INDICATORS

INTRODUCTION

BE1-51 controls and indicators are located on the front panel and right-side interior. The controls and indicators are shown in Figure 2-1 and described in Table 2-1. Your relay may not have all of the controls and indicators shown and described here.

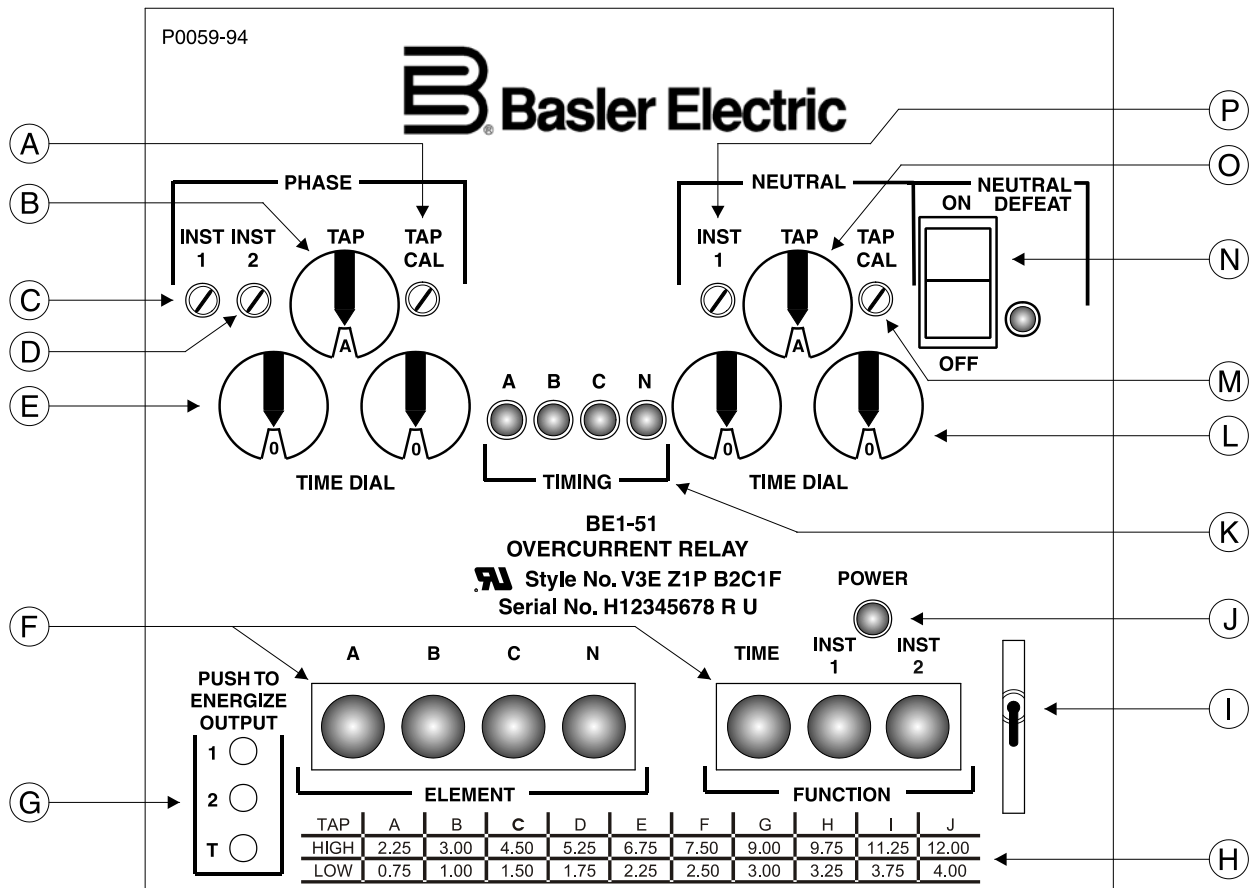

Figure 2-1. Location of Controls and Indicators

Table 2-1. Controls and Indicators

- A *Phase Tap Calibration Control*. This single-turn potentiometer adjusts the phase overcurrent pickup threshold between the selected phase tap setting and the next lower tap setting.
- B *Phase Tap Selector*. Selects the phase overcurrent pickup point in conjunction with the front panel Phase Tap Calibration Control (locator A).
- C *Phase Instantaneous 1 Control*. This four-turn potentiometer adjusts the phase instantaneous 1 element trip setting over the range of 1 to 40 times the selected Phase Tap Selector (locator B) setting value.
- D *Phase Instantaneous 2 Control*. This four-turn potentiometer adjusts the phase instantaneous 2 element trip setting over the range of 1 to 40 times the selected Phase Tap Selector (locator B) setting value.
- E *Phase Time Dial Selector*. These two knobs set the time delay between sensing of a phase overcurrent condition and closing of the output contacts. See Appendix A for curve selection information.
- F *Target Indicators*. LED indicators latch on when the corresponding output relay is energized by an overcurrent condition. Target indicators are reset by the Target Reset Switch (locator H).
- G *Push-to-Energize Output Pushbuttons*. These recessed pushbuttons are depressed to energize the external trip circuits for testing purposes. A thin, non-conducting rod should be used to depress the buttons. Do not use a screwdriver.
- H *Tap Selector Table*. This front-panel reference lists the high and low setting limits for a particular tap selection.
- I *Target Reset Switch*. Operating this switch resets all active targets (locator F).
- J *Power Indicator*. This LED indicator lights when control power is applied and the relay power supply is functioning.
- K *Timing Indicators*. A Timing LED lights when the corresponding overcurrent pickup point is reached and exceeded.
- L *Neutral Time Dial Selector*. These two knobs set the time delay between sensing of a neutral overcurrent condition and closing of the output contacts. See Appendix A for curve selection information.
- M *Neutral Tap Calibration Control*. This single-turn potentiometer adjusts the phase overcurrent pickup threshold between the selected neutral tap setting and the next lower tap setting.
- N *Neutral Defeat Switch and LED*. This switch enables (ON) and disables (OFF) the neutral defeat function. The corresponding LED lights when the neutral defeat function is enabled (ON).
- O *Neutral Tap Selector*. Selects the neutral overcurrent pickup point in conjunction with the front panel Neutral Tap Calibration Control (locator M).
- P *Neutral Instantaneous 1 Control*. This four-turn potentiometer adjusts the neutral instantaneous 1 element trip setting over the range of 1 to 40 times the selected Neutral Tap Selector (locator O) setting value.

The time overcurrent characteristic curve selector (not shown) is located on the right-side interior. This circuit board mounted switch selects the characteristic curve to be used.

The normal/test slide switch (not shown) is located on the right-side interior. This switch is only used for factory testing and must be in the normal position (towards rear of relay) for proper operation.

The tap range plate (not shown) indicates the terminal connections (high or low) used to select the current sensing input range. The sensing input ranges are listed in Table 2-2.

Table 2-2. Sensing Input Ranges

TAP Range Plate or Pickup	TAP Selector										Current Sensing Terminals			
	A	B	C	D	E	F	G	H	I	J	ØA	ØB	ØC	N
Sensing Input Range 1, Single-Phase *														
HIGH	2.25	3.00	4.50	5.25	6.75	7.50	9.00	9.75	11.25	12.00	8,7	—	—	—
LOW	0.75	1.00	1.50	1.75	2.25	2.50	3.00	3.25	3.75	4.00	9,7	—	—	—
Sensing Input Range 1, Three-Phase *														
HIGH	2.25	3.00	4.50	5.25	6.75	7.50	9.00	9.75	11.25	12.00	8,7	14,15	17,18	—
LOW	0.75	1.00	1.50	1.75	2.25	2.50	3.00	3.25	3.75	4.00	9,7	13,15	16,18	—
Sensing Input Range 1, Two-Phase-and-Neutral *														
HIGH	2.25	3.00	4.50	5.25	6.75	7.50	9.00	9.75	11.25	12.00	8,7	—	14,15	17,18
LOW	0.75	1.00	1.50	1.75	2.25	2.50	3.00	3.25	3.75	4.00	9,7	—	13,15	16,18
Sensing Input Range 2, Three-Phase-and-Neutral														
Phase or Neutral	0.75	1.00	1.50	1.75	2.25	2.50	3.00	3.25	3.75	4.00	8,9	13,14	15,16	17,18
Sensing Input Range 3, Three-Phase-and-Neutral														
Phase	2.25	3.00	4.50	5.25	6.75	7.50	9.00	9.75	11.25	12.00	8,9	13,14	15,16	—
Neutral	0.75	1.00	1.50	1.75	2.25	2.50	3.00	3.25	3.75	4.00	—	—	—	17,18
Sensing Input Range 4, Three-Phase-and-Neutral														
Phase	0.75	1.00	1.50	1.75	2.25	2.50	3.00	3.25	3.75	4.00	8,9	13,14	15,16	—
Neutral	2.25	3.00	4.50	5.25	6.75	7.50	9.00	9.75	11.25	12.00	—	—	—	17,18
Sensing Input Range 5, Three-Phase-and-Neutral														
Phase or Neutral	2.25	3.00	4.50	5.25	6.75	7.50	9.00	9.75	11.25	12.00	8,9	13,14	15,16	17,18
Sensing Input Range 6, Three-Phase-and-Neutral														
Phase or Neutral	0.15	0.20	0.30	0.35	0.45	0.50	0.60	0.65	0.75	0.80	8,9	13,14	15,16	17,18
Sensing Input Range 7, Three-Phase-and-Neutral														
Phase	0.45	0.60	0.90	1.05	1.35	1.50	1.80	1.95	2.25	2.40	8,9	13,14	15,16	—
Neutral	0.15	0.20	0.30	0.35	0.45	0.50	0.60	0.65	0.75	0.80	—	—	—	17,18
Sensing Input Range 8, Three-Phase-and-Neutral														
Phase or Neutral	0.45	0.60	0.90	1.05	1.35	1.50	1.80	1.95	2.25	2.40	8,9	13,14	15,16	17,18
Sensing Input Range 9 (All Other Sensing Types) *														
HIGH	0.45	0.60	0.90	1.05	1.35	1.50	1.80	1.95	2.25	2.40	Same as Range 1			
LOW	0.15	0.20	0.30	0.35	0.45	0.50	0.60	0.65	0.75	0.80	Same as Range 1			

* For relays with sensing input ranges 1 or 9, connect the system wiring to the current sensing terminals for the desired range (HIGH or LOW).

Refer to Table 2-3 for target installation configurations.

Table 2-3. Target Installation Configurations

Sensing Input Type	Number of Instantaneous Elements			Targets Installed (Types A and B)							
	None	One	Two	Element				Function			
				A	B	C	N	TIME	INST 1	INST 2	
K	X								X		
		X							X	X	
			X						X	X	X
G	X			X	X	X					
		X		X	X	X			X	X	
			X	X	X	X			X	X	X
H	X			X	X	X	X				
		X		X	X	X	X		X	X	
			X	X	X	X	X		X	X	X
X	X			X		X	X		X		
		X		X		X	X		X	X	
			X	X		X	X		X	X	X

SECTION 3 • FUNCTIONAL DESCRIPTION

TABLE OF CONTENTS

SECTION 3 • FUNCTIONAL DESCRIPTION.....	3-1
GENERAL	3-1
BLOCK DIAGRAM ANALYSIS	3-1
Power Supply	3-2
Current Sensing	3-2
Tap Select and Tap Cal.....	3-2
Neutral Defeat	3-2
Multiplexor	3-2
Analog-To-Digital Converter and Level Detector	3-2
Time Trip Comparator and Scaler	3-2
Microprocessor (Not Shown).....	3-2
Instantaneous Overcurrent (Options 1-1 and 1-2)	3-3
Timed and Instantaneous Outputs	3-3
Auxiliary Outputs	3-3
Push-to-Energize Pushbuttons.....	3-3
Power Supply Status Output (Option 3-6).....	3-3
Target Indicators	3-3
Figures	
Figure 3-1. Functional Block Diagram	3-1

This page intentionally left blank.

SECTION 3 • FUNCTIONAL DESCRIPTION

GENERAL

BE1-51 Time Overcurrent Relays are microprocessor-based devices that provide protection for the phase or phase and neutral time and instantaneous overcurrent functions.

BLOCK DIAGRAM ANALYSIS

The following block diagram analysis is referenced to Figure 3-1. A microprocessor (not illustrated in Figure 3-1) processes signals, performs logic functions, and all of the time overcurrent computations.

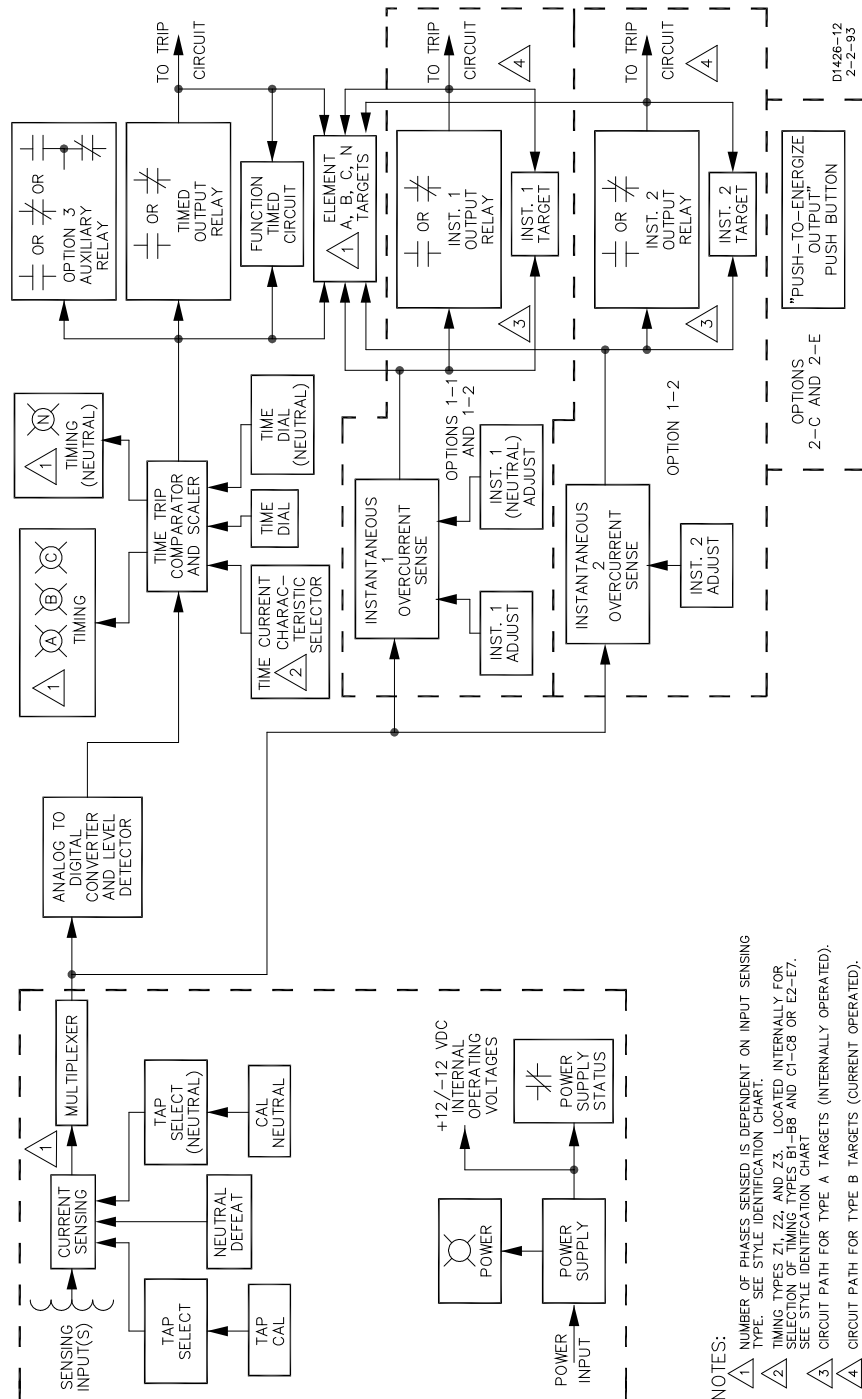

Figure 3-1. Functional Block Diagram

Power Supply

Operating power for the relay circuitry is supplied by a wide range, electrically isolated, low-burden power supply. Power supply operating power is not polarity sensitive. The front panel power LED and power supply status output indicate when the power supply is operating. Power supply specifications are listed in Table 1-1.

Current Sensing

All relay models (except three-phase-and-neutral units) have two sensing ranges for each phase. Each high/low sensing range has its own set of input terminal connections.

- Five ampere CTs have: LOW (0.5 A to 4.0 A) and HIGH (1.5 A to 12.0 A).
- One ampere CTs have: LOW (0.1 A to 0.8 A) and HIGH (0.3 A to 2.4 A).

Three-phase-and-neutral sensing units, however, have one of four possible combinations of input sensing ranges with one range for neutral and one range for the phases.

- Five ampere CTs have: 0.5 A to 4.0 A and 1.5 A to 12.0 A.
- One ampere CTs have: 0.1 A to 0.8 A and 0.3 A to 2.4 A.

Tap Select and Tap Cal

Front panel **TAP** selectors and **TAP CAL** controls are provided for selection and precise adjustment of the phase and neutral (if provided) time overcurrent pickup points. The front panel **TAP** selectors, ten-position BCD weighted rotary switches, select the desired current sensing pickup point, while the front panel **TAP CAL** controls provide precise adjustment between the selected setting and the next lower setting.

Neutral Defeat

Front panel mounted switch allows neutral current sensing to be disabled. When the switch is set to ON, a current imbalance in the neutral circuit will not trip the output contacts.

Multiplexor

The multiplexor sequentially switches a voltage representing each of the sensed input currents to the analog-to-digital converter and level detector.

Analog-To-Digital Converter and Level Detector

Analog dc voltages representing the sensed currents from the multiplexor are converted to binary numbers (successive approximation) and applied to the time trip comparator and scaler circuits.

Time Trip Comparator and Scaler

This circuit accepts both the binary number representing the detected current level and the desired time delay characteristic selected by the front panel **TIME DIAL**, then computes the required time delay before the timed output relay will be energized. Time delay characteristics are shown in the curves located in Appendix A. If extended timing range options 2-D or 2-E is present, the time delay characteristic curves are modified so that the time delay is approximately 5.7 times the derived value.

Time delay computations are updated continuously so that changes in the overcurrent condition are monitored and result in a corresponding change in the time delay. A software counter begins counting when the initial binary number is received from the analog-to-digital converter and level detector. The counter measures the elapsed time of the overcurrent condition, and resets if the current decreases below the pickup point. This continuously increasing binary number is then passed to the comparator.

Microprocessor (Not Shown)

Some of the circuitry already discussed is part of the microprocessor and no definite lines are drawn to separate the functions. The microprocessor compares the desired time delay (from the time trip comparator and scaler) with the actual elapsed time from the counter. When the elapsed time reaches the intended delay, the timed output relay is energized. During the time delay period, the front panel TIMING indicator (i.e. pickup) associated with the detected phase is illuminated.

If targets are present, the front panel **TIME FUNCTION** target will be tripped, and the **A, B, C, or N ELEMENT** target associated with the detected phase will be tripped. See Table 2-3 for the types of targets that are present (depending upon relay configuration).

If option 3 is present, an auxiliary output relay (with N.O., N.C., or SPDT contacts) is also actuated when the timed output relay energizes.

Instantaneous Overcurrent (Options 1-1 and 1-2)

Input current levels applied to the time overcurrent circuitry are also passed to the instantaneous overcurrent circuitry. These levels are compared to the setting of the front panel **INST 1** adjust and the front panel **INST 1 (NEUTRAL)** adjust (if present). If the input current level is above the setting, the output driver energizes the instantaneous 1 output relay. If the instantaneous 2 option is present, the input level is also compared with the setting of the front panel **INST 2** adjust to energize the instantaneous 2 output relay. Not that the current level settings for the instantaneous overcurrent element will always be from 1 to 40 times above the front panel **TAP** and **TAP (NEUTRAL)** settings of the time overcurrent element.

If target type A or B is present, the front panel **INST 1** target and the front panel **INST 2** targets are tripped when their respective output relay is energized, along with the front panel **A, B, C or N ELEMENT** targets (if present) associated with the detected phases. (See Section 2, *Controls and Indicators*, for the types of targets that can be present depending upon the relay configuration.)

Timed and Instantaneous Outputs

Each output signal (representing either time overcurrent or instantaneous overcurrent) from each monitored phase (or neutral) is applied to the respective output driver. Each output driver supplies operating current to energize the associated output relay. Either normally open (output type E) or normally closed (output type G) contacts may be specified. (The contact configurations of all output relays for a given model will be the same.)

Auxiliary Outputs

In addition to the output relays, an auxiliary relay, having the same or a different contact configuration, may be specified. Both the output and the auxiliary relays will remain energized for the duration of the overcurrent condition.

Push-to-Energize Pushbuttons

If either option 2-C or 2-E is present, each individual output relay can be directly energized for test purposes by the actuation of a front panel **PUSH-TO-ENERGIZE OUTPUT** pushbutton. The pushbutton is actuated by the insertion of a thin, non-conducting rod through an access hole in the front panel.

Power Supply Status Output (Option 3-6)

Power supply status output relays have a set of normally closed contacts that are energized open during power-up. If either or both power supply output legs (+12 Vdc or -12 Vdc) fails, the power supply status output relay is de-energized and the output contacts close. Shorting bars across the output contacts are held open by the installed connection plug. When the relay is removed from service by removing the connection plug, the shorting bars are closed.

Target Indicators

Target indicators are optional components selected when a relay is ordered. The electronically latched and reset targets consist of red LED indicators located on the relay front panel. A latched target is reset by operating the target reset switch on the front panel. If relay operating power is lost, any illuminated (latched) targets are extinguished. When relay operating power is restored, the previously latched targets are restored to their latched state.

A relay can be equipped with either internally operated targets or current operated targets.

Internally Operated Targets

The relay trip outputs are directly applied to drive the appropriate target indicator. Each indicator is illuminated regardless of the current level in the trip circuit.

Current Operated Targets

A current operated target is triggered by closure of the corresponding output contact and the presence of at least 200 milliamperes of current flowing in the trip circuit.

Note that the front panel function targets (**TIMED**, **INST 1**, etc.) may be either internally or current operated. Phase and neutral indicators are current operated only if the instantaneous options are not included and if current operated targets are specified.

NOTE

Prior to August 2007, BE1-51 target indicators consisted of magnetically latched, disc indicators. These mechanically latched target indicators have been replaced by the electronically latched LED targets in use today.

SECTION 4 • INSTALLATION

TABLE OF CONTENTS

SECTION 4 • INSTALLATION.....	4-1
INTRODUCTION.....	4-1
RELAY OPERATING GUIDELINES AND PRECAUTIONS	4-1
MOUNTING.....	4-1
CONNECTIONS.....	4-7
MAINTENANCE.....	4-14
STORAGE.....	4-14

Figures

Figure 4-1. Outline Dimensions, Side View, Semi-Flush Mounted, Double-Ended Case.....	4-2
Figure 4-2. Outline Dimensions, Side View, Projection Mounted, Double-Ended Case.....	4-3
Figure 4-3. Outline Dimensions, Front View, Case Cover.....	4-4
Figure 4-4. Panel Cutting and Drilling Dimensions, Semi-Flush Mounting, Double-Ended Case.....	4-5
Figure 4-5. Panel Drilling Dimensions, Projection Mounting, Double-Ended Case	4-6
Figure 4-6. Typical External Connections, Current Operated Targets, DC Powered	4-7
Figure 4-7. Typical Sensing External Connections, Sensing Input Type G or K.....	4-8
Figure 4-8. Typical Sensing External Connections, Sensing Input Type I or X	4-8
Figure 4-9. Typical Sensing External Connections, Sensing Input Type H or V	4-9
Figure 4-10. Typical Internal Diagram, Sensing Input Type K	4-10
Figure 4-11. Typical Internal Diagram, Sensing Input Type I or X	4-11
Figure 4-12. Typical Internal Diagram, Sensing Input Type G	4-12
Figure 4-13. Typical Internal Diagram, Sensing Input Type H or V.....	4-13

This page intentionally left blank.

SECTION 4 • INSTALLATION

INTRODUCTION

BE1-51 relays are shipped in sturdy cartons to prevent damage during transit. Upon receipt of a relay, check the model and style number against the requisition and packing list to see that they agree. Inspect the relay for shipping damage. If there is evidence of damage, file a claim with the carrier, and notify your sales representative or Basler Electric.

If the relay will not be installed immediately, store it in its original shipping carton in a moisture- and dust-free environment. Before placing the relay in service, it is recommended that the test procedures of Section 5, *Tests and Adjustments* be performed.

RELAY OPERATING GUIDELINES AND PRECAUTIONS

Before installing or operating the relay, note the following guidelines and precautions.

- For proper current operated target operation, a minimum current of 200 milliamperes must flow through the output trip circuit.
- If a wiring insulation test is required, remove the connection plugs and withdraw the relay from its case.

CAUTION

When the connection plugs are removed, the relay is disconnected from the operating circuit and will not provide system protection. Always be sure that external operating (monitored) conditions are stable before removing a relay for inspection, test, or service.

NOTE

Be sure that the BE1-51 is hard-wired to earth ground with no smaller than 12 AWG copper wire attached to the ground terminal on the rear of the case. When the BE1-51 is configured in a system with other devices, it is recommended to use a separate lead to the ground bus from each device.

MOUNTING

Because the relay is of solid-state design, it does not have to be mounted vertically. Any convenient mounting angle may be chosen. Refer to Figures 4-1 through 4-5 for relay outline dimensions and panel drilling diagrams.

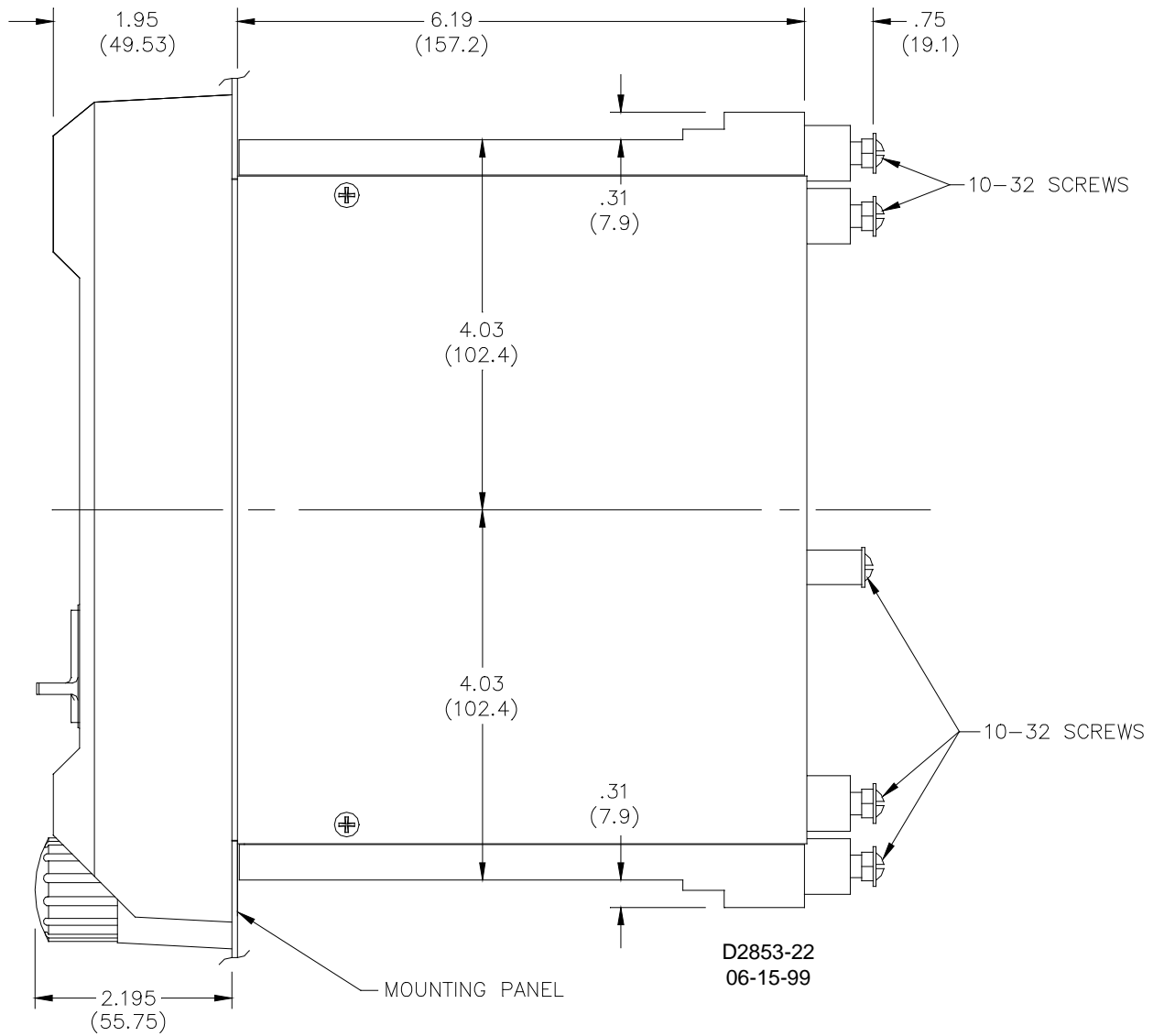

Figure 4-1. Outline Dimensions, Side View, Semi-Flush Mounted, Double-Ended Case

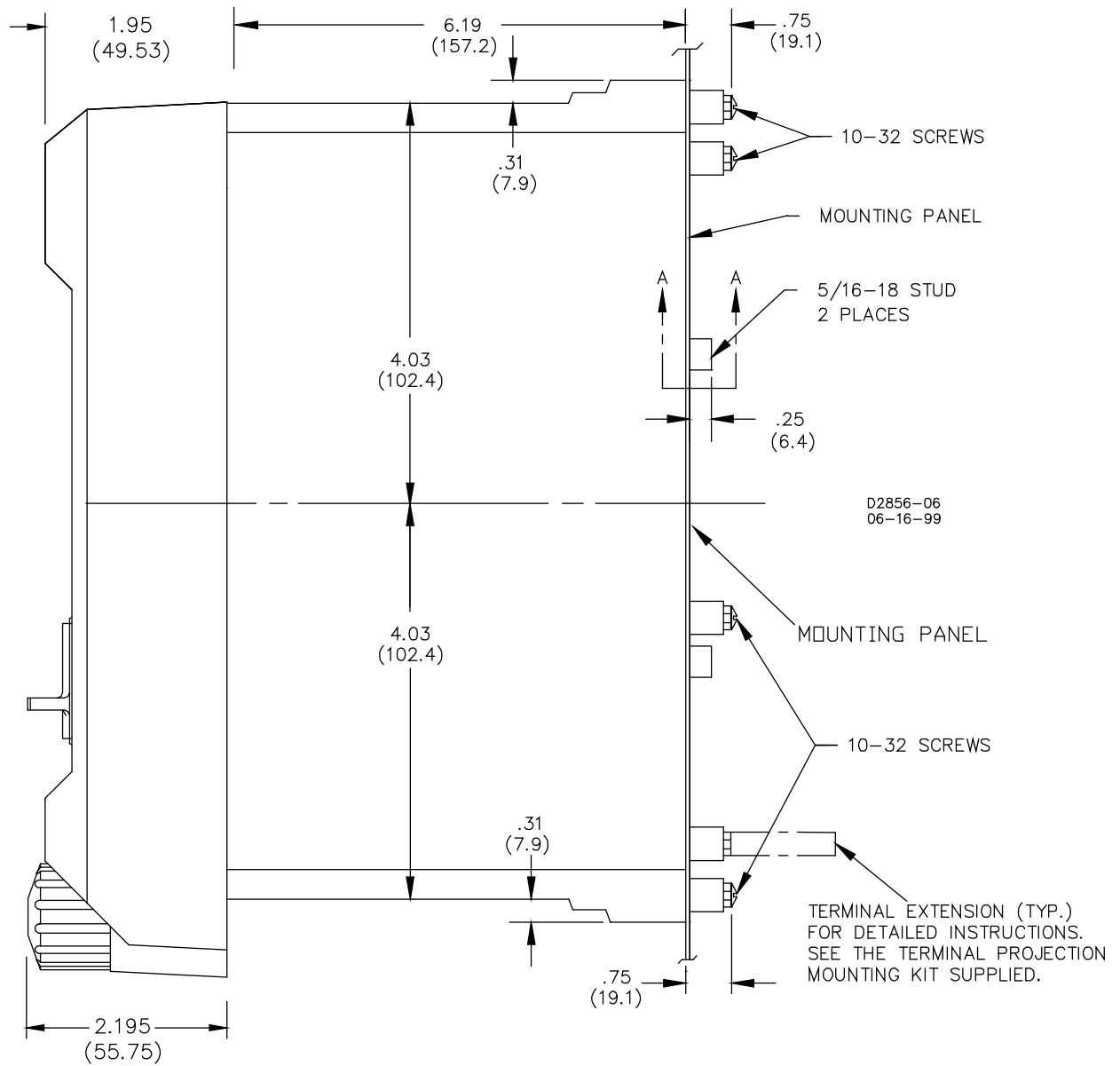

Figure 4-2. Outline Dimensions, Side View, Projection Mounted, Double-Ended Case

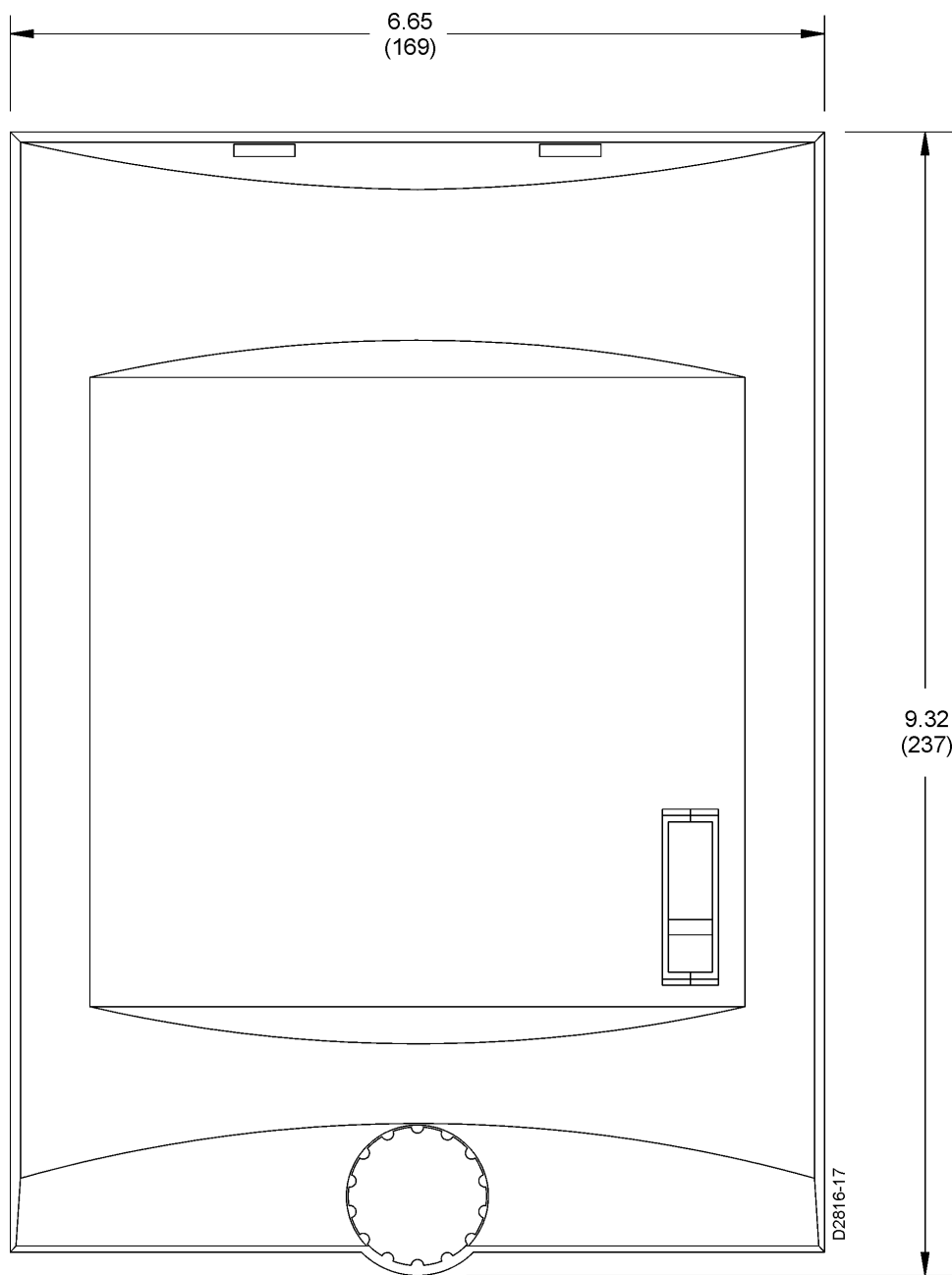

Figure 4-3. Outline Dimensions, Front View, Case Cover

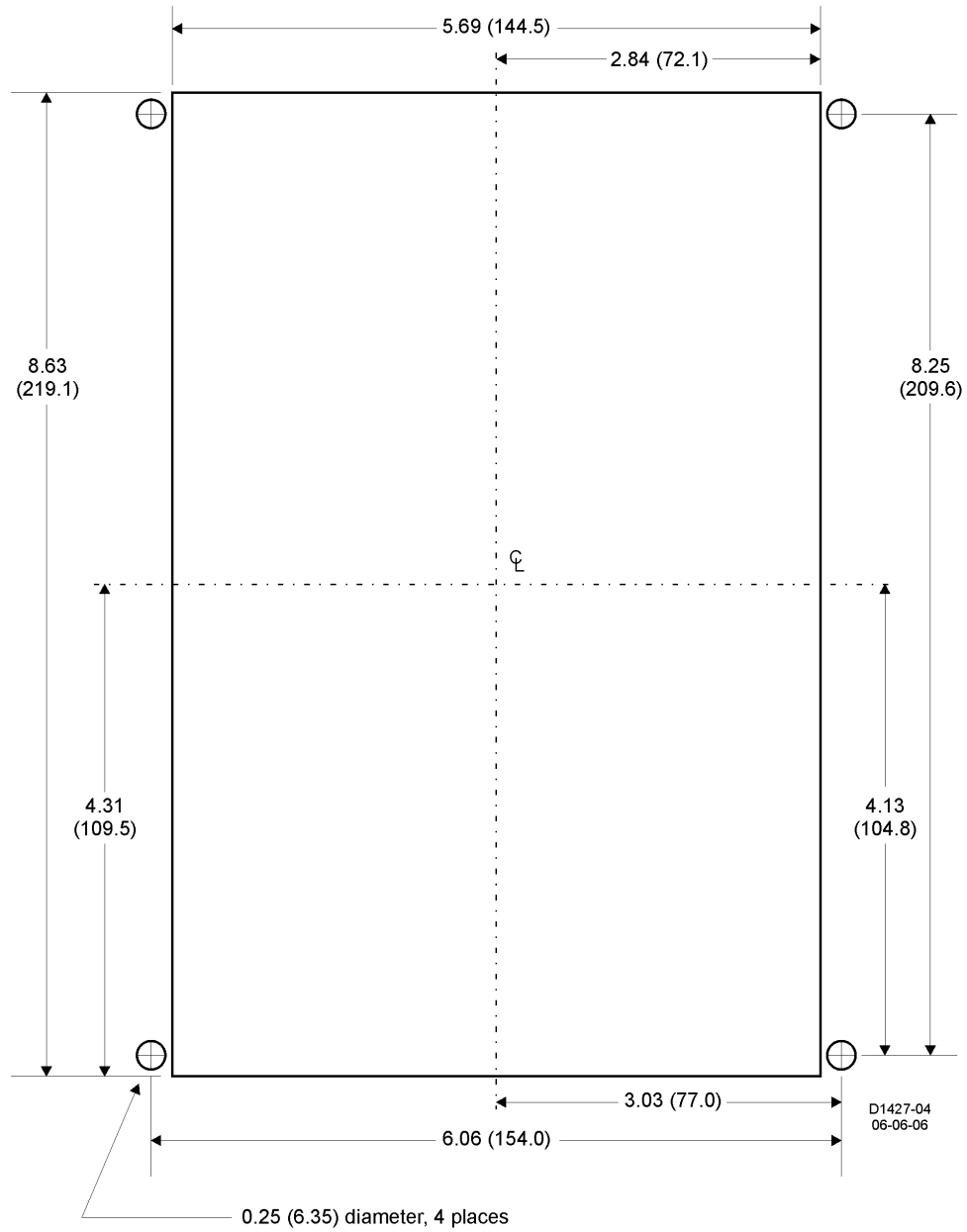

Figure 4-4. Panel Cutting and Drilling Dimensions, Semi-Flush Mounting, Double-Ended Case

CONNECTIONS

Be sure to check the model and style number of a relay before connecting and energizing the relay. Incorrect wiring may result in damage to the relay. Except where noted, connections should be made with wire no smaller than 14 AWG.

Typical external connections are shown in Figures 4-6 through 4-9. Internal connections are shown in Figures 4-10 through 4-13.

To prevent an inductive overload of the relay contacts, it is necessary to break the trip circuit externally through the 52a contacts.

Relay circuitry is connected to the case terminals by removable connection plugs (1 plug for 10-terminal cases and 2 plugs for 20-terminal cases). Removal of the connection plug(s) opens the normally open trip contact circuits and shorts the normally closed trip circuits before opening the power and sensing circuits.

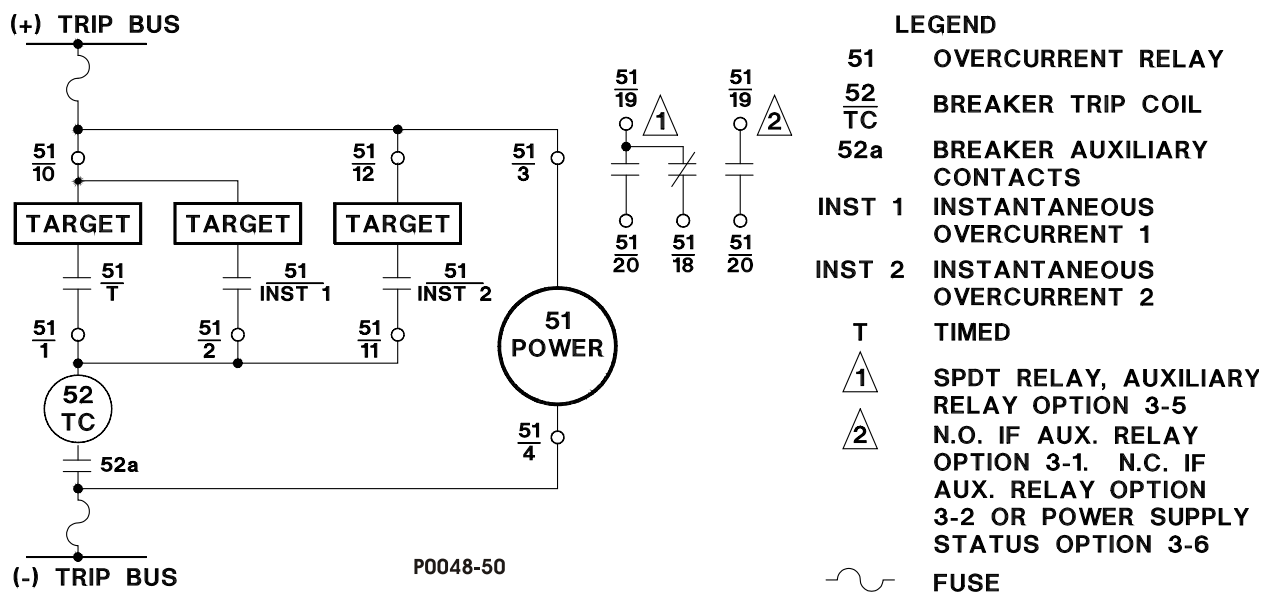

Figure 4-6. Typical External Connections, Current Operated Targets, DC Powered

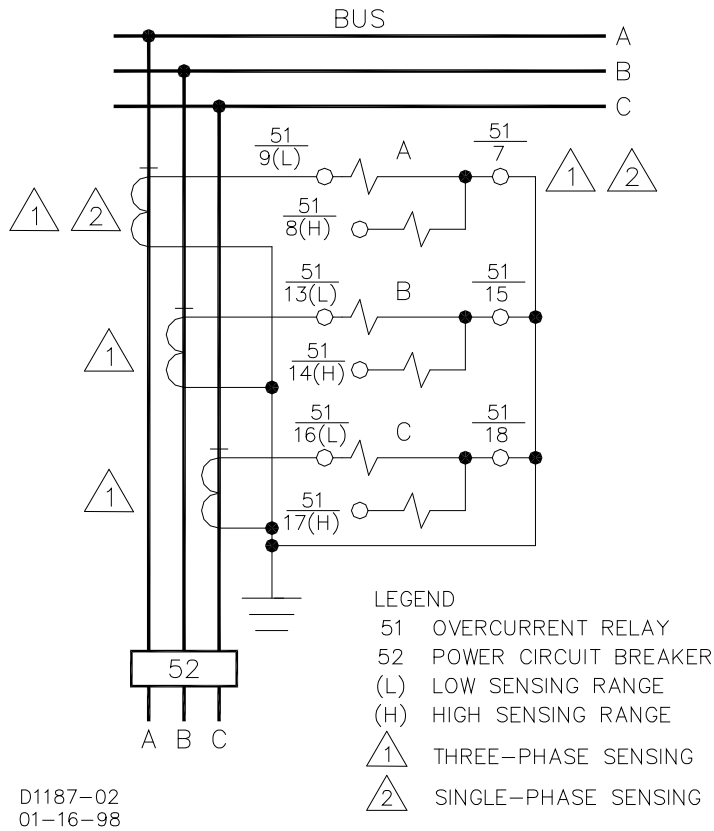

Figure 4-7. Typical Sensing External Connections, Sensing Input Type G or K

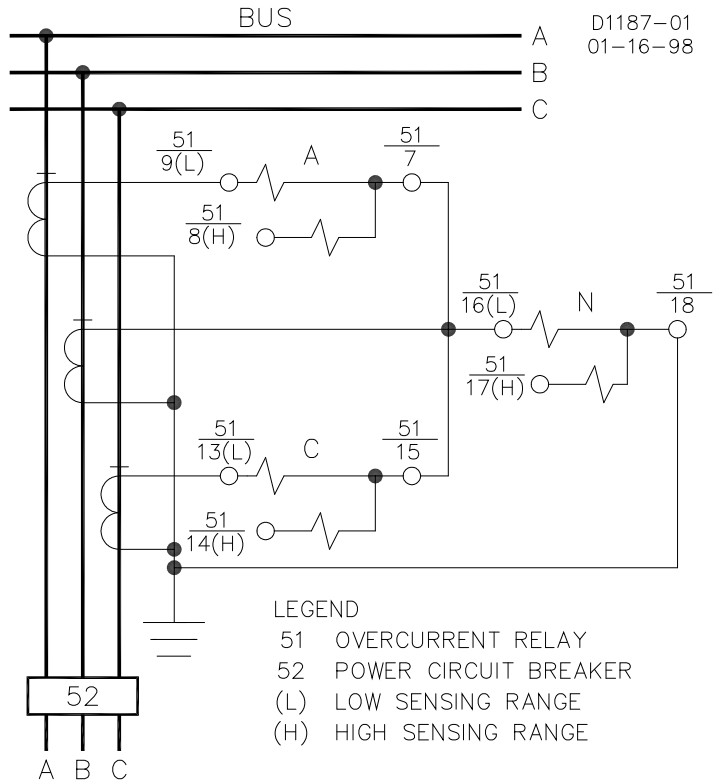

Figure 4-8. Typical Sensing External Connections, Sensing Input Type I or X

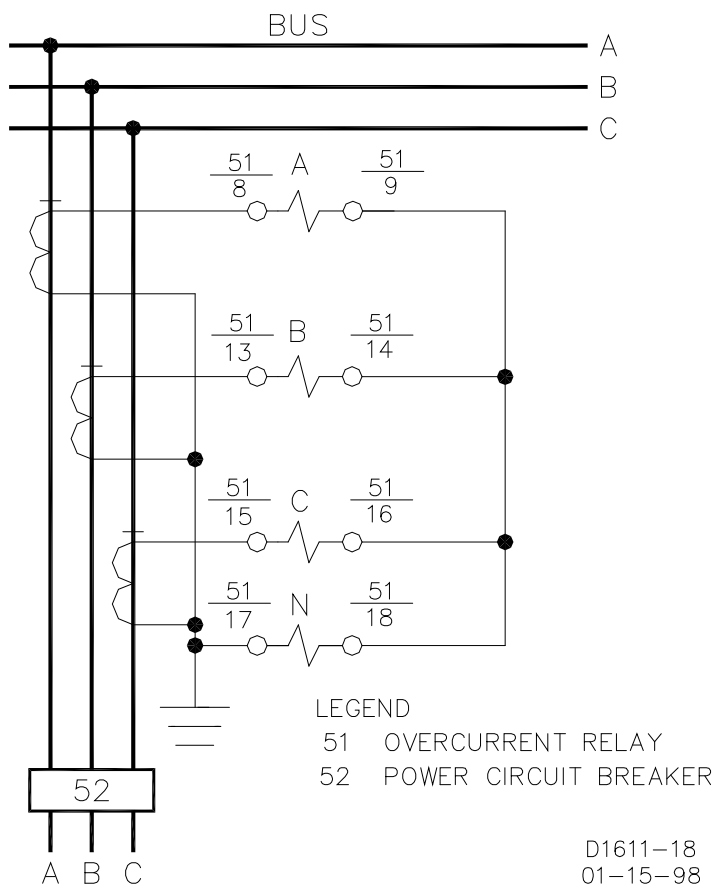

Figure 4-9. Typical Sensing External Connections, Sensing Input Type H or V

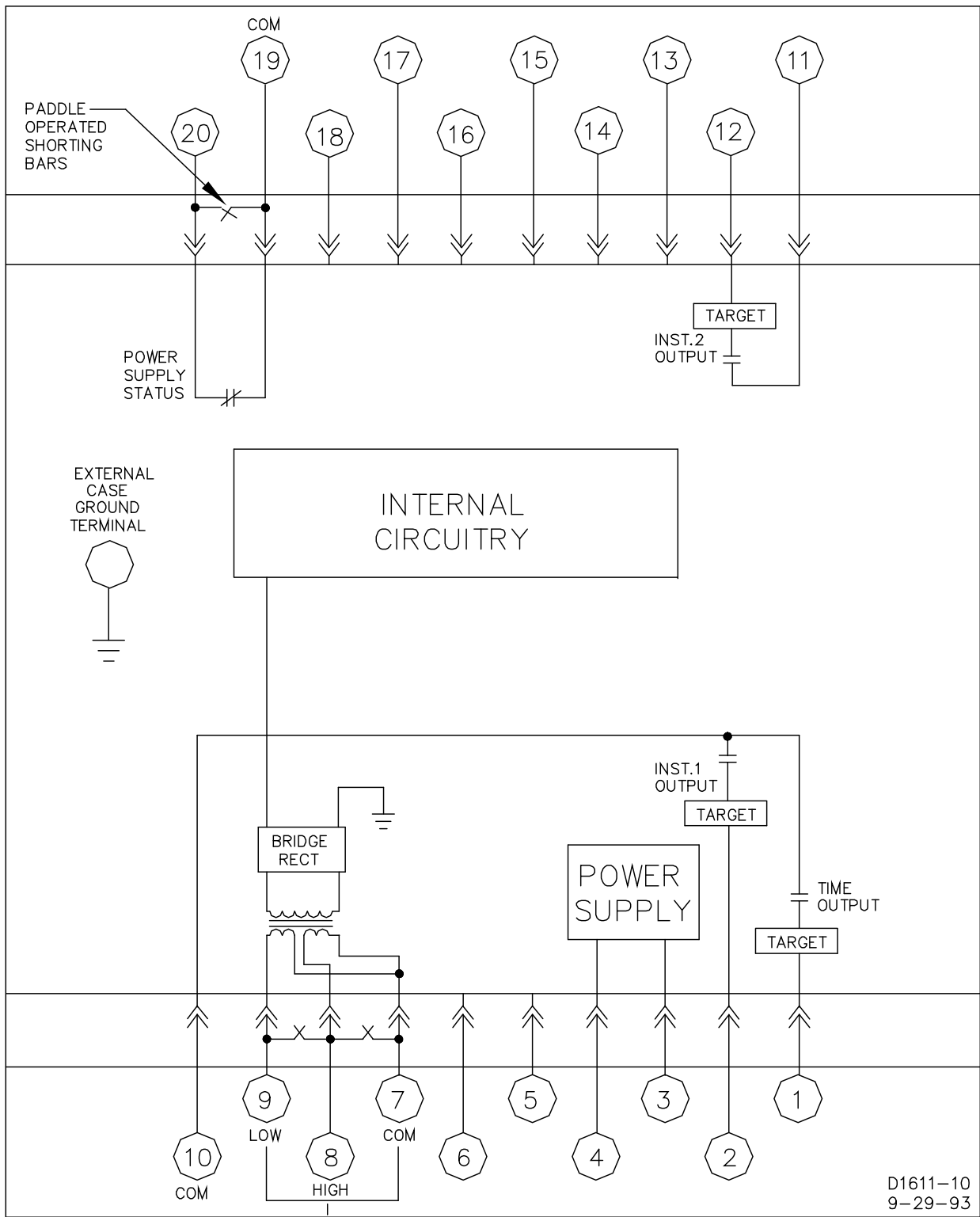
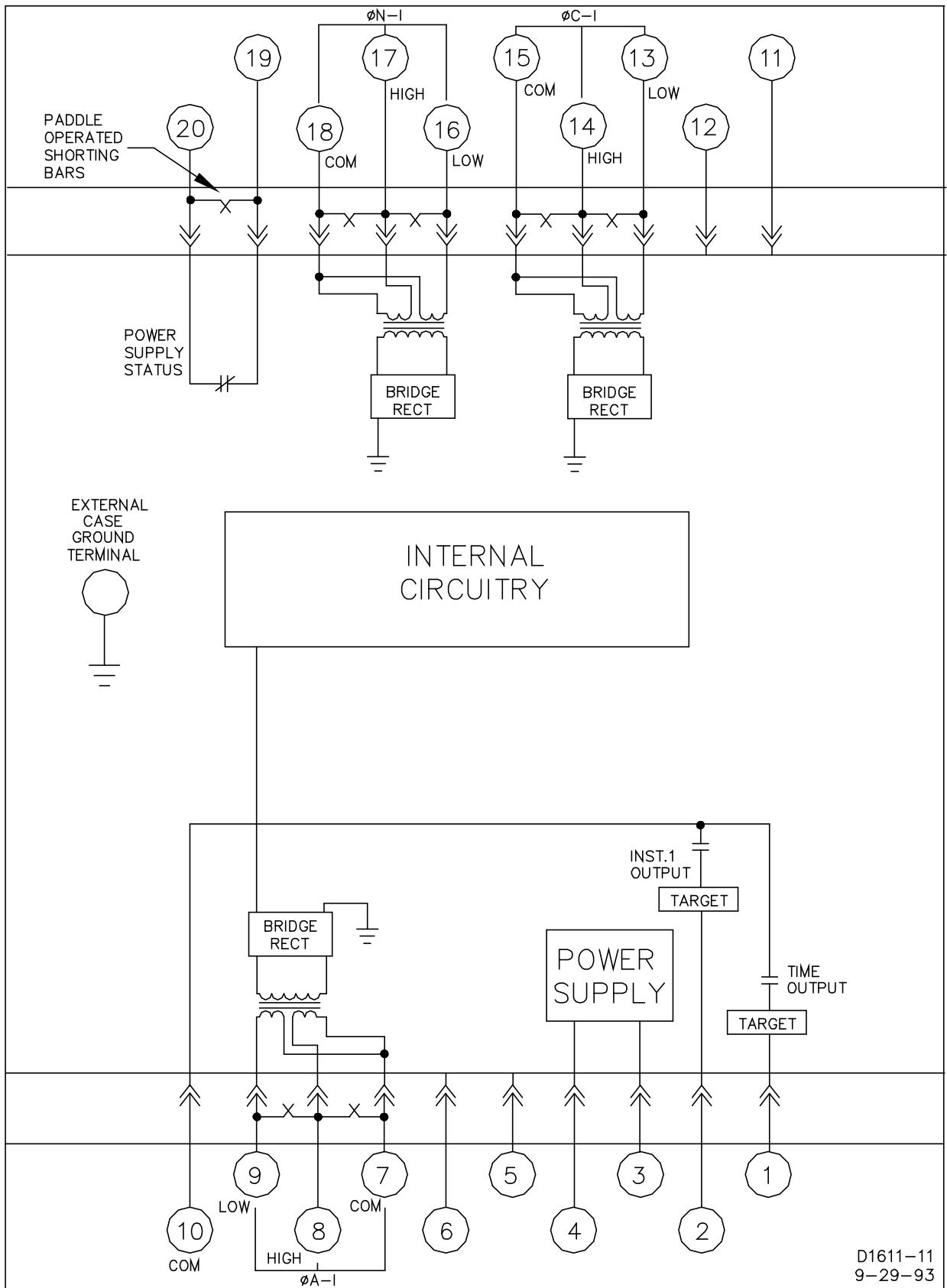

Figure 4-10. Typical Internal Diagram, Sensing Input Type K



D1611-11
9-29-93

Figure 4-11. Typical Internal Diagram, Sensing Input Type I or X

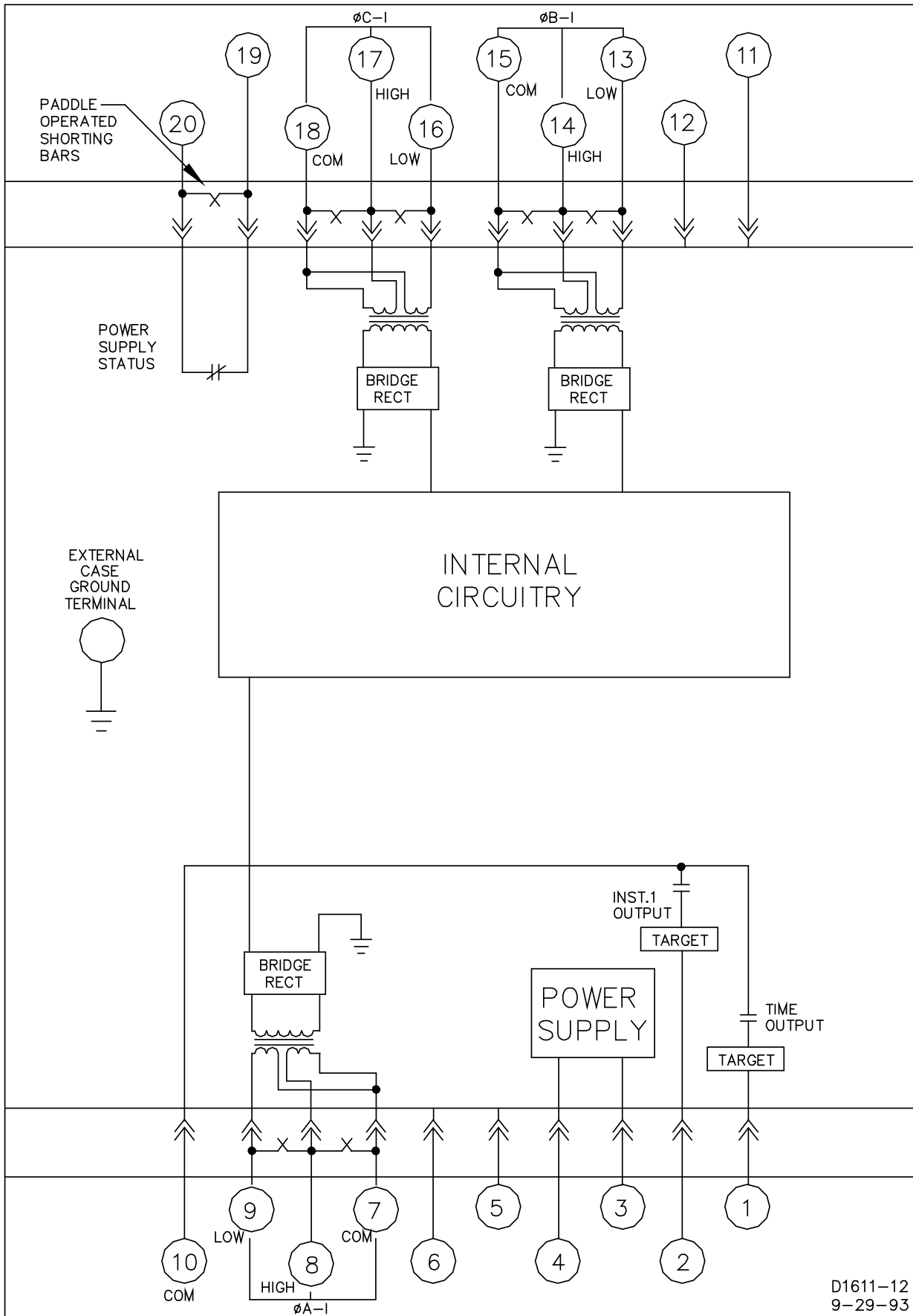

Figure 4-12. Typical Internal Diagram, Sensing Input Type G

MAINTENANCE

BE1-51 relays require no preventative maintenance other than a periodic operational check. If the relay fails to function properly, contact Technical Sales Support at Basler Electric to coordinate repairs.

STORAGE

This device contains long-life aluminum electrolytic capacitors. For devices that are not in service (spares in storage), the life of these capacitors can be maximized by energizing the device for 30 minutes once per year.

SECTION 5 • TESTS AND ADJUSTMENTS

TABLE OF CONTENTS

SECTION 5 • TESTS AND ADJUSTMENTS	5-1
GENERAL	5-1
REQUIRED TEST EQUIPMENT	5-1
OPERATIONAL TEST	5-1
Preliminary Instructions	5-1
Time Overcurrent Pickup Test.....	5-3
Neutral Defeat Test	5-5
Timed Output Test.....	5-5
Instantaneous Overcurrent Pickup Test.....	5-7
ADJUSTMENTS OF CONTROLS FOR RELAY OPERATION	5-8
TAP and TAP (NEUTRAL) Selector Setting.....	5-8
Time Overcurrent Curve Selection (Timing Type Z1, Z2, and Z3 Only)	5-9
Time Delay Selection	5-10
Neutral Time Delay Selection.....	5-10
INST 1 Control Setting	5-10
INST 2 Control Setting	5-11

Figures

Figure 5-1. Test Setup for Sensing Input Type K (Single-Phase Sensing)	5-2
Figure 5-2. Test Setup for Sensing Input Type G (Three-Phase Sensing)	5-2
Figure 5-3. Test Setup for Sensing Input Type H or V (Three-Phase with Neutral Sensing)	5-3
Figure 5-4. Test Setup for Sensing Input Type I or X (Two-Phase with Neutral Sensing).....	5-3

This page intentionally left blank.

SECTION 5 • TESTS AND ADJUSTMENTS

GENERAL

Procedures in this section are for use in testing and adjusting a relay for the desired operation in a protective scheme. If a relay fails an operational test, or if an adjustment discloses a faulty relay, refer to Section 4, *Installation, Maintenance*.

REQUIRED TEST EQUIPMENT

Minimum test equipment required for relay testing and adjustment is listed below. Refer to Figures 5-1 through 5-4 for test setups.

- Appropriate ac or dc power source for relay operation.
 - Appropriate ac source (50 or 60 hertz as appropriate) for current testing.
 - Dc external power source for output relay(s) test setup and timer input.
 - Relay test set capable of delivering 40 amperes. A higher capability is needed for instantaneous settings above 40 amperes.
 - Timer.
 - One shunt resistor for providing minimum target load.
-

OPERATIONAL TEST

Preliminary Instructions

Perform the following steps before going on to any testing.

Step 1. Connect the relay test setup in accordance with Figures 5-1 through 5-4, depending upon the sensing input type for your relay (see Figure 1-1, *Style Number Identification Chart*).

- (a) *Sensing Input Type K (Single-Phase Sensing)*. Refer to Figure 5-1.

NOTE

For relays having the above sensing, only the front panel **LOW** range current sense terminal(s) should be connected for a complete check of the relay.

Ensure that timed output terminals 1 and 10 are connected.

- (b) *Sensing Input Type G (Three-Phase Sensing)*. Refer to Figure 5-2.

NOTE

For relays having the above sensing, only the front panel **LOW** range current sense terminal(s) should be connected for a complete check of the relay.

For all three-phase relays, the test signals must connect to both the current and voltage terminals for the same phase.

Ensure that timed output terminals 1 and 10 are connected.

- (c) *Sensing Input Type H or V (Three-Phase with Neutral Sensing)*. Refer to Figure 5-3.

Ensure that the timed output terminals 1 and 10 are connected. Also, verify that either A, B, or C current sense terminals are connected initially (N terminals will be connected later in the test).

- (d) Sensing Input Type I or X (Two-Phase with Neutral Sensing). Refer to Figure 5-4.
 Ensure that the timed output terminals 1 and 10 are connected. Also, verify that either A, B, or C current sense terminals are connected initially (N terminals will be connected later in the test).

- Step 2. Remove the relay front cover.
 Step 3. Set the front panel **TIME DIAL** selector and, if present, the front panel **TIME DIAL (NEUTRAL)** selector to 99.
 Step 4. Adjust the front panel **INST 1** and **INST 2** controls, if present, fully clockwise (CW).
 Step 5. Adjust the front panel **TAP CAL** control, and if present, the front panel **TAP (NEUTRAL)** control fully CW.
 Step 6. Ensure that the relay front panel **TARGETS**, if present, are reset.

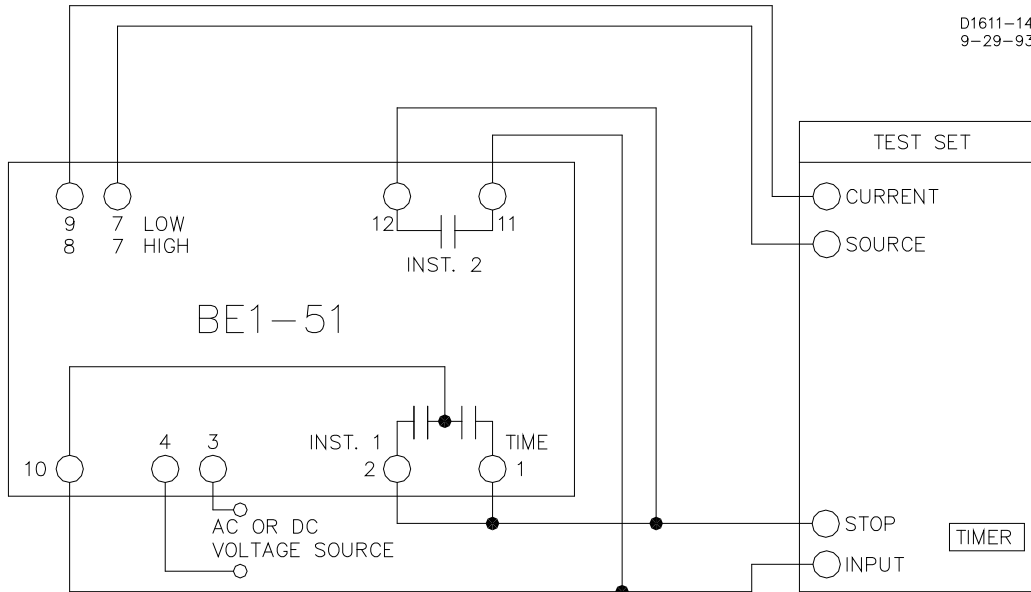

Figure 5-1. Test Setup for Sensing Input Type K (Single-Phase Sensing)

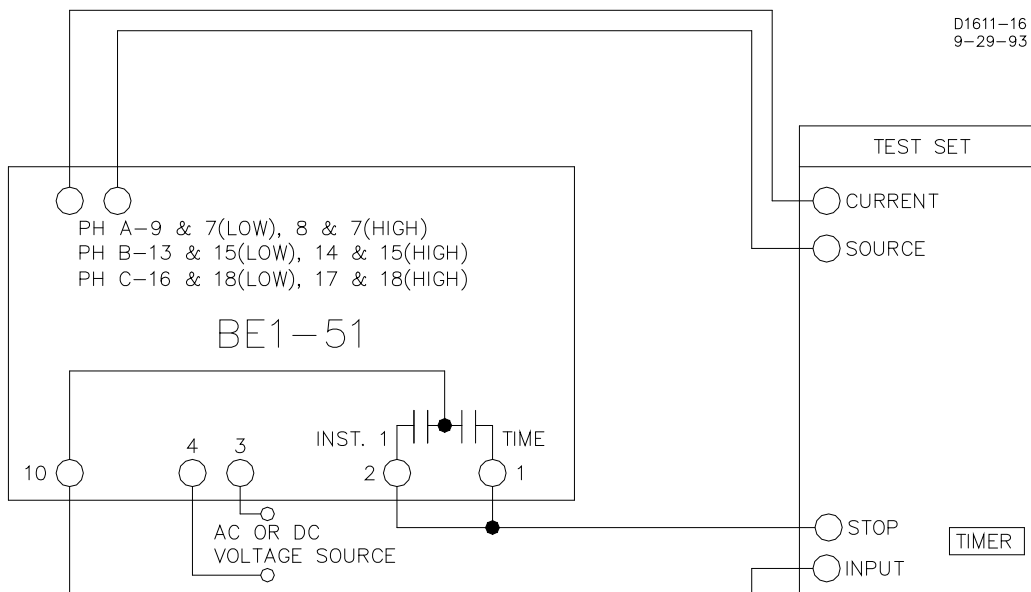

Figure 5-2. Test Setup for Sensing Input Type G (Three-Phase Sensing)

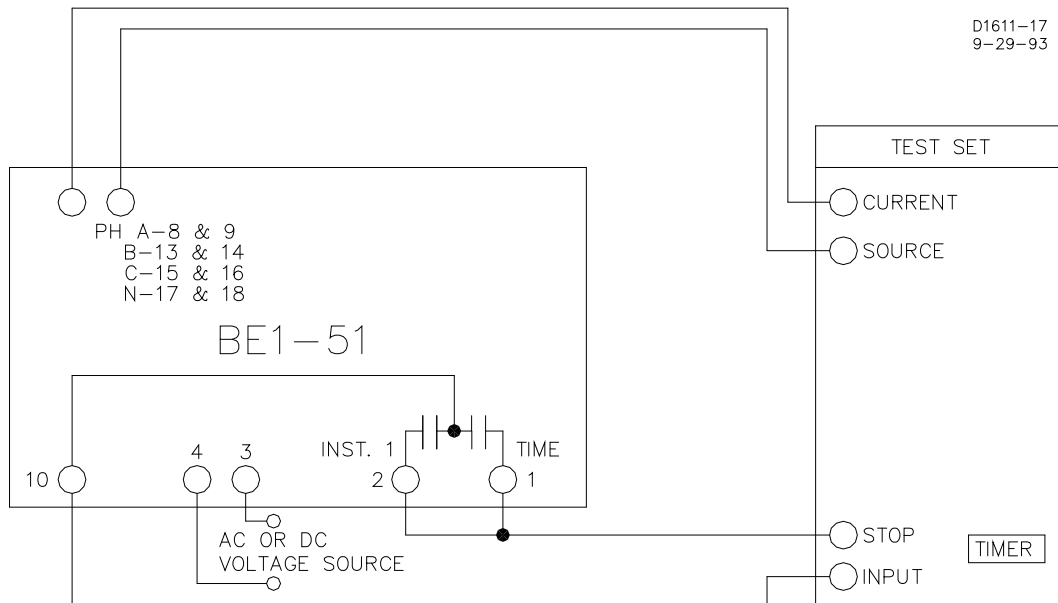

Figure 5-3. Test Setup for Sensing Input Type H or V (Three-Phase with Neutral Sensing)

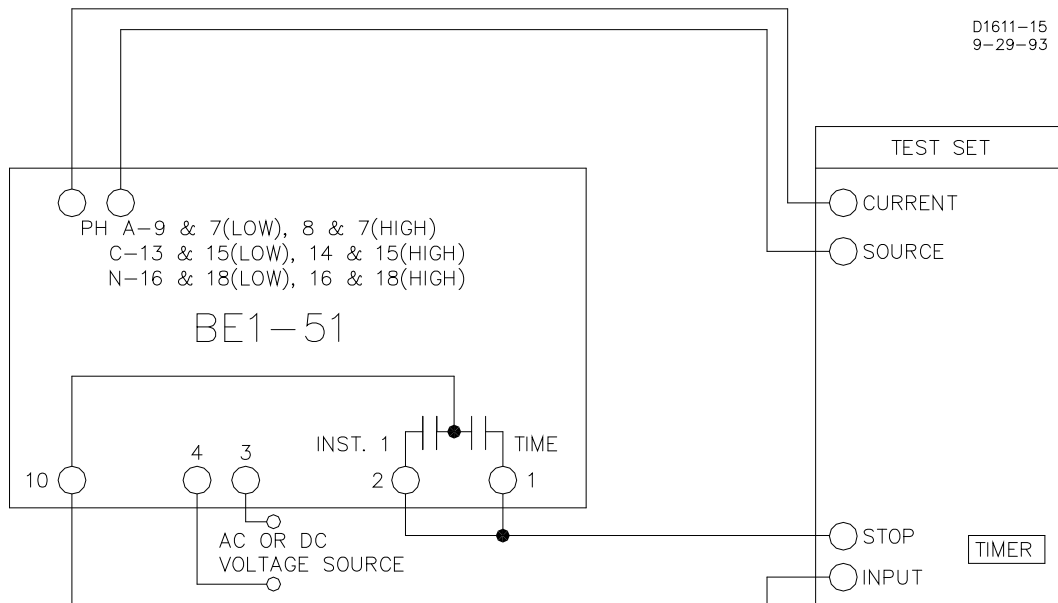

Figure 5-4. Test Setup for Sensing Input Type I or X (Two-Phase with Neutral Sensing)

Time Overcurrent Pickup Test

This test checks the minimum and maximum overcurrent pickup points of the time overcurrent element.

NOTE

During this test, disregard any indication on the test setup timer.

- Step 1. Perform the preliminary instructions.
- Step 2. Set the front panel **TAP** selector to **A**.
- Step 3. Adjust the test set, for an overcurrent threshold having one of the following values:
 - (a) 0.5 for relays with Sensing Input Range 1, 2, or 4.
 - (b) 1.5 A for relays with Sensing Input Range 3 or 5.

- Step 4. Slowly adjust the front panel **TAP CAL** control CCW until the front panel **TIMING** indicator illuminates.
- RESULT:** For the phase minimum overcurrent pickup point of 0.5 A (Step 3a, above) or 1.5 A (Step 3b, above) the front panel **TAP CAL** control should be near its maximum CCW limit.
- Step 5. Adjust the front panel **TAP CAL** control fully CW to allow measurement of the actual overcurrent pickup point at the **A** setting of the front panel **TAP** selector. Note that the front panel **TIMING** indicator will extinguish. Do not disturb this setting.
- Step 6. Slowly increase the current toward the value of the front panel **TAP** selector **A** setting until the front panel **TIMING** indicator illuminates. Do not disturb this setting.
- Step 7. Record the current reading and remove input current.
- RESULT:** The recorded value should be within $\pm 5\%$ of the front panel **TAP** selector **A** setting for the phase minimum overcurrent pickup point for the time overcurrent.
- Step 8. Set the front panel **TAP** selector to **J**.
- Step 9. Slowly adjust the test set, increasing the overcurrent threshold toward the value of the front panel **TAP** selector **J** setting until the front panel **TIMING** indicator just illuminates. Do not disturb this setting.
- Step 10. Record the current reading and remove input current.
- RESULT:** The recorded value should be within $\pm 5\%$ of the front panel **TAP** selector **J** setting for the phase maximum overcurrent pickup point for the time overcurrent element.
- Step 11. Perform the following steps as appropriate for the correct sensing input types.
- Sensing Input Type K (Single-Phase Sensing). This concludes the time overcurrent test. Proceed to the timed output test.
 - Sensing Input Type I or X (Two-Phase and Neutral Sensing). Remove the power and reconnect the input sensing to the remaining phases as shown in Figure 5-4, each time repeating Steps 1 through 10. For neutral testing, continue with Step 12.
 - Sensing Input Type G (Three-Phase Sensing). Remove the power and reconnect the input sensing to each of the remaining phases as shown in Figure 5-2, each time repeating Steps 1 through 10.
 - Sensing Input Type H or V (Three-Phase with Neutral Sensing). Remove the power and reconnect the input sensing to each of the remaining phases as shown in Figure 5-3, each time repeating Steps 1 through 10. For neutral testing, continue with Step 12.
- Step 12. Perform the preliminary instructions.
- For the neutral sensing (terminals 17 and 18), connect the relay as shown in Figures 5-3 and 5-4, then perform the following steps (Steps 13 through 21).
- Step 13. Set the front panel **TAP (NEUTRAL)** selector to **A**.
- Step 14. Adjust the test set for an overcurrent threshold having one of the following values:
- 0.5 A for relays with Sensing Input Range 2 or 3.
 - 1.5 A for relays with Sensing Input Range 4 or 5.
- Step 15. Slowly adjust the front panel **CAL (NEUTRAL)** control CCW until the front panel **TIMING** indicator illuminates.
- RESULT:** For the neutral minimum overcurrent pickup point of 0.5 A (Step 16a, above) or 1.5 A (Step 16b, above) the front panel **CAL (NEUTRAL)** control should be near its maximum CCW limit.
- Step 16. Adjust the front panel **CAL (NEUTRAL)** control fully CW to allow measurement of the actual overcurrent pickup point at the **A** setting of the front panel **TAP (NEUTRAL)** selector. Note that the front panel **TIMING (NEUTRAL)** indicator will extinguish. Do not disturb this setting.
- Step 17. Slowly increase the current toward the value of the front panel **TAP (NEUTRAL)** selector **A** setting until the front panel **TIMING (NEUTRAL)** indicator illuminates. Do not disturb this setting.
- Step 18. Record the current reading and remove input current.

RESULT: The recorded value should be within $\pm 5\%$ of the front panel **TAP (NEUTRAL)** selector **A** setting for the neutral minimum overcurrent pickup point for the time overcurrent.

- Step 19. Set the front panel **TAP (NEUTRAL)** selector to **J**.
- Step 20. Slowly adjust the test set, increasing the overcurrent threshold toward the value of the front panel **TAP (NEUTRAL)** selector **J** setting until the front panel **TIMING (NEUTRAL)** indicator just illuminates. Do not disturb this setting.
- Step 21. Record the current reading and remove input current.

RESULT: The recorded value should be within $\pm 5\%$ of the front panel **TAP (NEUTRAL)** selector **J** setting for the neutral maximum overcurrent pickup point for the time overcurrent element.

Neutral Defeat Test

- Step 1. Perform the preliminary instructions.
- Step 2. Set the front panel **NEUTRAL TAP** selector to **A**.
- Step 3. Set the front panel **NEUTRAL TIME DIAL** selector to 00.
- Step 4. Apply two times (200%) input current of tap **A** to neutral terminals and allow relay to time out (trip).
- Step 5. Set the front panel **NEUTRAL DEFEAT** switch to **ON** (up).

RESULT:

- (1) **NEUTRAL DEFEAT** LED illuminates.
- (2) **NEUTRAL TIMING** LED extinguishes.
- (3) Output relay opens (closes if NC).

- Step 6. Set the front panel **NEUTRAL DEFEAT** switch to **OFF** (down).

RESULT:

- (1) **NEUTRAL DEFEAT** LED extinguishes.
- (2) **NEUTRAL TIMING** LED illuminates.
- (3) Output relay closes (opens if NC) after appropriate time delay.

- Step 7. Remove input current.

Timed Output Test

This test checks the accuracy of the time overcurrent characteristic delay.

NOTE

For relays having three-phase sensing (Sensing Input Type G or V), only a single input phase needs to be connected, since this is sufficient for a complete test of the Time Delay. For relays that include neutral sensing (Sensing Input Type H, I, V, or X) this test includes reconnecting the Test Output to the Neutral Sensing terminals for testing the Timed Output during neutral sensing.

- Step 1. Verify that the preliminary instructions have been performed.
- Step 2. (Timing type Z1, Z2, or Z3 only.) Select the desired time current characteristic curve.
- Step 3. Set the front panel **TAP** selector to **B**.
- Step 4. Adjust the front panel **TIME DIAL** to **20**.
- Step 5. Adjust the test set for an overcurrent threshold of precisely 5 times the front panel **TAP** selector **B** setting.
- Step 6. Apply input current to the relay and initiate the test setup timer.
- Step 7. Observe that the appropriate front panel **TIMING** indicator illuminates and when the time delay ends that the timed output relay is energized.

RESULTS:

- (1) The appropriate front panel **TIMING** indicator extinguishes.
- (2) The test setup timer stops. (Record count for use in Step 9.)

(3) If target type A or B is present:

(a) The front panel **FUNCTION-TIME** target (if present) trips.

(b) The appropriate front panel **ELEMENT** target **A**, **B**, or **C** (if present) trips.

Step 8. Remove input current and (if present) reset the relay front panel targets.

NOTE

Due to delays inherent in the test equipment, the time delay for the following test may appear to exceed these limits.

Step 9. On the appropriate time overcurrent curve chart (Figures A-1 through A-69), locate the line representing 5 times the tap value (from Step 5) where it intersects the particular curve representing the front panel **TIME DIAL** setting of **20** (from Step 4). The resulting time delay value in seconds should be within $\pm 5\%$ of the timer reading [from Step 7(2)].

Step 10. Adjust the front panel **TIME DIAL** to **40**, **60**, and **99**, each time repeating Steps 6 through 9.

NOTE

For relays having two-phase-and-neutral, three-phase, or three-phase-and-neutral sensing (Sensing Input Types G, H, I, V, or X) it is not necessary to repeat this test for the remaining phases.

For relays having two-phase-and-neutral, or three-phase-and-neutral sensing (Sensing Input Types H, I, V, or X) perform Steps 11 through 20.

For relays having single-phase or three-phase sensing (Sensing Input Types G or K) with instantaneous overcurrent option 1-1 or 1-2, proceed to the instantaneous overcurrent test.

Step 11. Remove the power and reconnect the test output to the neutral current sensing input of the relay as shown in Figures 5-3 and 5-4 (terminals 17 and 18).

Step 12. Set the front panel **TAP (NEUTRAL)** selector to **B**.

Step 13. Rotate the front panel **CAL (NEUTRAL)** control fully CW.

Step 14. Rotate the front panel **TIME DIAL (NEUTRAL)** to **20**.

Step 15. Ensure that all relay targets have been reset.

Step 16. Adjust the test set for an overcurrent threshold of precisely 5 times the front panel **TAP (NEUTRAL)** selector **B** setting as measured by the ammeter.

Step 17. Apply input current to the relay and initiate the test setup timer.

RESULTS: Observe that the appropriate front panel **TIMING (NEUTRAL)** indicator illuminates.

Step 18. When the time delay ends, the timed output relay is energized.

RESULTS: (1) The front panel **TIMING (NEUTRAL)** indicator extinguishes.

(2) The test setup timer stops. (Record count for use in Step 20.)

(3) If target Type A or B is present:

(a) Front panel **FUNCTION-TIME** target (if present) trips.

(b) Appropriate front panel **ELEMENT** target **A**, **B**, or **C** (if present) trips.

Step 19. Remove input current and (if present) reset the relay front panel targets.

Step 20. On the appropriate time overcurrent curve chart (Figures A-1 through A-69), locate the line representing 5 times the tap value (from Step 5) where it intersects the particular curve representing the front panel **TIME DIAL (NEUTRAL)** setting of **20** (from Step 14). The resulting time delay value in seconds should be within $\pm 5\%$ of the timer reading [from step 18(2)].

NOTE

Due to delays inherent in the test equipment, the time delay may appear to exceed these limits. This concludes the timed output test.

Relays having instantaneous overcurrent option 1-1 or 1-2 only proceed to the Instantaneous Overcurrent Pickup Test.

Instantaneous Overcurrent Pickup Test

This test checks the minimum overcurrent pickup points for Instantaneous 1 and (if present) Instantaneous 2 outputs.

NOTE

For relays having three-phase sensing (Sensing Input Types G or V), only a single input phase is connected since this is sufficient for a complete test of the instantaneous overcurrent sensing and output.

For relays that include neutral sensing (Sensing Input Types H, I, V, or X), this test includes reconnecting the test output to the neutral sensing terminals for testing the instantaneous 1 output during neutral sensing.

- Step 1. Perform the preliminary instructions.
- Step 2. Reconnect the test setup to the INST 1 output terminals 2 and 10 as shown in Figures 5-1 through 5-4. Note that the timer may be removed from the test setup at this time.
- Step 3. Set the **TAP** selector to **A**.
- Step 4. Turn the front panel **INST 1** control fully CCW to establish a pickup point of 1 times the **TAP** selector **A** setting.
- Step 5. Slowly adjust the test set, increasing the overcurrent threshold toward the value of the front panel **TAP** selector **A** setting until the Instantaneous 1 output relay energizes.
RESULT: If target Type A or B is present:
 - (a) The front panel **FUNCTION-INST 1** target (if present) will trip.
 - (b) The appropriate front panel **ELEMENT** target **A**, **B**, or **C** (if present) will trip.
- Step 6. Remove input current. Record the test set current setting.
RESULT: The recorded value should be equal to or less than the front panel **TAP** selector **A** setting for the minimum overcurrent pickup point for the instantaneous 1 overcurrent element.
- Step 7. Reset the relay front panel targets (if present).
- Step 8. Turn the front panel **INST 1** control fully CW to establish a pickup point of 40 times the front panel **TAP** selector **A** setting.
- Step 9. Adjust the test set to approximately 35 times the front panel **TAP** selector **A** setting.
- Step 10. Slowly adjust the test set further toward an overcurrent threshold of 40 times the front panel **TAP** selector **A** setting until the instantaneous 1 output relay energizes. Do not disturb this setting.
RESULT: If target Type A or B is present:
 - (a) The front panel **FUNCTION-INST 1** target (if present) will trip.
 - (b) The appropriate front panel **ELEMENT** target **A**, **B**, or **C** (if present) will trip.
- Step 11. Record the current reading. Remove input current (the front panel **TIMING** indicator should extinguish).
RESULT: The recorded value should be greater than 40 times the front panel **TAP** selector **A** setting for the maximum overcurrent pickup point for the instantaneous 1 overcurrent element.

NOTE

For relays having neutral sensing (Sensing Input Types H, I, V, or X) perform Step 12. For relays with option 1-2 (INST 2 elements), perform Step 13. Otherwise, the test ends here.

- Step 12. For the neutral sensing, connect the relay as shown in Figures 5-3 and 5-4, then repeat Steps 2 through 11, substituting the following:
- (a) The front panel **TAP (NEUTRAL)** selector instead of the front panel **TAP** selector (Step 3).
 - (b) The front panel **INST 1 (NEUTRAL)** control instead of the front panel **INST 1** control (Step 4).
- Step 13. Reconnect the test setup to the INST 2 output terminals (11 and 12) as shown in Figure 5-1 then repeat Steps 4 through 11, substituting the following:
- (a) Front panel **INST 2** control instead of the front panel **INST 1** control (Step 3).
 - (b) Front panel **FUNCTION-INST 2** target instead of the front panel **INST 1** target (Step 4).
 - (c) Instantaneous 2 output relay instead of the instantaneous 1 output relay (Step 2).

ADJUSTMENTS OF CONTROLS FOR RELAY OPERATION

The following procedures set up the relay for use in a protective scheme. The procedures are arranged in a logical sequence that prevents upsetting previous control settings. For relays not having certain options, skip the corresponding adjustment paragraph. These paragraphs are identified by their headings.

TAP and TAP (NEUTRAL) Selector Setting

NOTE

Selection of one of the specific overcurrent pickup points provided by the front panel **TAP** selector (and with the front panel **TAP CAL** control fully CW) will permit a pickup point within $\pm 5\%$ of the selector value without having to connect the relay to a test setup to verify the setting. If present, the front panel **TAP (NEUTRAL)** selector and the front panel **CAL (NEUTRAL)** control provide this function for the neutral overcurrent pickup point

However, if the desired pickup point falls between these front panel **TAP** selector settings, or if the instantaneous overcurrent option 1-1 or 1-2 is present, the relay should be connected to a test setup for a precise setting, then the following steps should be performed.

- Step 1. Connect the test setup to the relay according to the sensing input type present in the relay as follows:
- (a) *Sensing Input Type K*: Refer to Figure 5-1. Because the relay front panel **TIMING** indicator provides the needed pickup indication, do not connect the test setup to the output terminals. The current sense terminals for the desired range (HIGH or LOW), however, should be connected to the relay.
 - (b) *Sensing Input Types I or X*: Refer to Figure 5-4. Because the relay front panel **TIMING** indicator provides the needed pickup indication, do not connect the test setup to the output terminals. The front panel **TAP** selector is ganged and the adjustment of one input phase automatically aligns the other, thus, only one set of current sense terminals need be connected. For adjustment of the front panel **TAP (NEUTRAL)** selector, the relay is reconnected for neutral sensing by this procedure.
 - (c) *Sensing Input Type G*: Refer to Figure 5-2. Because the relay front panel **TIMING** indicator provides the needed pickup indication, do not connect the test setup to the output terminals. The desired range terminals (HIGH or LOW), however, should be connected to the relay. The front panel **TAP** selector is ganged and the adjustment of one input phase automatically aligns the others, thus, only one set of current sense terminals need be connected.

- (d) *Sensing Input Types H or V*: Refer to Figure 5-3. Because the relay front panel **TIMING** indicator provides the needed pickup indication, do not connect the test setup to the output terminals. The front panel **TAP** selector is ganged and the adjustment of one input phase automatically aligns the others, thus, only one set of current sense terminals need be connected. For adjustment of the front panel **TAP (NEUTRAL)** selector, the relay is reconnected for neutral sensing by this procedure.

- Step 2. Remove the relay front cover.
- Step 3. *Sensing Input Types G, I, K, or X*. Verify that the front panel **TAP RANGE** plate is installed and the correct range (HIGH or LOW) is visible.
- Step 4. Adjust the test current to the desired time overcurrent pickup point for the relay.
- Step 5. Set the front panel **TAP** selector to the closest setting above the desired pickup point.
- Step 6. Adjust the front panel **TAP CAL** control fully CW.
- Step 7. Apply current to the relay.
- Step 8. Slowly adjust the front panel **TAP CAL** control CCW until the front panel **TIMING** indicator just illuminates which indicates the desired time overcurrent pickup point for phase sensing. For relays with two-phase-and-neutral, three-phase, or three-phase-and-neutral sensing, this pickup point will be the same for all the phases.
- Step 9. Remove input current.

NOTE

For relays with two-phase-and-neutral or three-phase-and-neutral sensing (Sensing Input Types I or V), perform Steps 10 through 15. Otherwise, the time overcurrent pickup point calibration ends here (unless instantaneous 1 or 2 overcurrent calibration is to be performed later in these procedures).

- Step 10. Reconnect the test set output to the neutral sense terminals. See Figures 5-3 or 5-4.
- Step 11. Adjust the current to the desired time overcurrent pickup point for the relay.
- Step 12. Set the front panel **TAP (NEUTRAL)** selector to the closest setting above the desired pickup point.
- Step 13. Rotate the front panel **CAL (NEUTRAL)** control fully CW.
- Step 14. Slowly adjust the front panel **CAL (NEUTRAL)** control CCW until the front panel **TIMING (NEUTRAL)** indicator just illuminates to establish the desired time overcurrent pickup point for neutral sensing.
- Step 15. Remove input current.

NOTE

Pickup point calibration ends here.

Time Overcurrent Curve Selection (Timing Type Z1, Z2, and Z3 Only)

- Step 1. Remove the relay cradle front cover to gain access to the logic board time overcurrent characteristic curve selector.
- Step 2. Remove the Phillips screws from both sides of the unit and remove the front panel. See Figure 2-1 for the location of the logic board and curve selector.
- Step 3. Select the desired curve. See Table A-2 for the desired curve and selector position.
- Step 4. Re-install the front panel and the front cover.

Time Delay Selection

NOTE

If Timing Type Z1, Z2, or Z3 is installed, refer to time overcurrent curve selection to obtain the desired set of time overcurrent curves (see Figures A-1 through A-69). Then proceed to Step 1, following.

If Timing Type Z1, Z2, or Z3 is not installed, determine the timing type from the model and style number for a specific relay. Then select the appropriate timing curve (see Figures A-1 through A-69). Proceed to the following, Step 1.

- Step 1. Referring to the appropriate time overcurrent characteristic curve, select the desired time delay on the front panel **TIME DIAL** for the anticipated input overcurrent difference (multiples-of-pickup current) from the selected time overcurrent pickup point as follows:
- (Selected Pickup Point) - (Anticipated Input Overcurrent) = Overcurrent Difference from Pickup
- Step 2. Set the front panel **TIME DIAL** as follows:
- On the appropriate curve, plot upward from the ***multiples-of-pickup-current*** value until the horizontal line opposite the desired time delay (***time-in-seconds***) is reached. The setting curve nearest the plot point should then be entered on the front panel **TIME DIAL**.
 - Using Figure A-5 as an example, if the overcurrent is expected to be 4 times the pickup point value and time delay of 4 seconds is desired, plot upward from the point 4 on the ***multiples-of-pickup-current*** axis until the point 4 from the ***time-in-seconds*** axis is crossed. The curve for a setting of **52** crosses the plot point and should be entered on the front panel **TIME DIAL**.
 - For a lesser overcurrent difference from the pickup point, the time delay will be greater, so that for a multiple of 3 times the pickup current, the time delay for the previous front panel setting of **52** will be 5.8 seconds.

Neutral Time Delay Selection

- Step 1. Use the same characteristic curve used in the previous paragraph (*Time Delay Selection*). However, ***the multiples-of-pickup current, time-in-seconds,*** and the resulting front panel **NEUTRAL TIME DIAL** setting can differ.
- Step 2. Set the front panel **NEUTRAL TIME DELAY** as follows:
- On the appropriate curve, plot upward from the ***multiples-of-pickup-current*** value until the horizontal line opposite the desired time delay (***time-in-seconds***) is reached. The setting curve nearest the plot point should then be entered on the front panel **NEUTRAL TIME DELAY**.
 - Using Figure A-5 as an example, if the overcurrent is expected to be 4 times the pickup point value and time delay of 4 seconds is desired, plot upward from the point 4 on the ***multiples-of-pickup-current*** axis until the point 4 from the ***time-in-seconds*** axis is crossed. The curve for a setting of **52** crosses the plot point and should be entered on the front panel **NEUTRAL TIME DIAL**.
 - For a lesser overcurrent difference from the pickup point, the time delay will be greater, so that for a multiple of 3 times the pickup current, the time delay for the previous front panel setting of **52** will be 5.8 seconds.

INST 1 Control Setting

NOTE

Because the lower limit for this pickup is determined by the front panel **TAP** selector setting and the front panel **TAP (CAL)** control position, ensure that these adjustments have been performed as in the paragraph *TAP and TAP (NEUTRAL) Selector Setting*.

- Step 1. Verify that the test setup is as described in *TAP and TAP (NEUTRAL) Selector Setting*, Steps 1 through 6.
- Step 2. Connect the test setup to the instantaneous 1 element output terminals (2 and 10) as shown in Figures 5-1 through 5-4. The timer should not be connected.

CAUTION

Steps 3 through 8 provide the application of overcurrent for short periods to allow adjustment while avoiding overheating of the input sensing transformers. To avoid damaging the relay, do not attempt to apply a constant high level of input current for adjustment of the front panel **INST 1**, **INST 1 (NEUTRAL)**, or **INST 2** controls.

- Step 3. Set the front panel **INST 1** control to a position approximating the desired instantaneous 1 overcurrent pickup point for the relay.
- Step 4. Apply current to the relay.
- Step 5. Rapidly increase the overcurrent input to the relay until the instantaneous output relay just energizes. Note the overcurrent threshold reading on the ammeter.
- Step 6. Remove input current.
- Step 7. Reset the **INST TARGET** (if present).
- Step 8. If the overcurrent threshold reading from Step 5 was too high or low, adjust the front panel **INST 1** control CCW to lower (or CW to raise) the instantaneous 1 overcurrent pickup point. Repeat Steps 4 through 8. If the overcurrent threshold reading from Step 5 was **NOT** too high or low, proceed to Step 9.

NOTE

For relays with two-phase-and-neutral or three-phase-and-neutral sensing (Sensing Input Types I or X), perform Steps 9 through 14.

- Step 9. Reconnect the output to the neutral current sense terminals. See Figures 5-3 or 5-4.
- Step 10. Set the front panel **INST 1 (NEUTRAL)** control to a position approximating the desired neutral instantaneous 1 overcurrent pickup point for the relay.
- Step 11. Apply current to the relay.
- Step 12. Rapidly increase the overcurrent input to the relay until the instantaneous output relay just energizes. Note the test set overcurrent threshold reading on the ammeter.
- Step 13. Remove the input current.
- Step 14. Reset the **INST TARGET** (if present).
- Step 15. If the overcurrent threshold reading from Step 13 was too high or low, adjust the front panel **INST 1 (NEUTRAL)** control CCW to lower (or CW to raise) the Neutral Instantaneous 1 Overcurrent Pickup Point. Repeat Steps 9 through 14. If **NOT**, proceed to the next test.

INST 2 Control Setting

For this adjustment, repeat *INST 1 Control Setting*, but substitute instantaneous 2 output terminals (11 and 12) and the front panel **INST 2** controls. Because neutral sensing does not apply to this pickup point, ignore Steps 9 through 15.

This page intentionally left blank.

APPENDIX A • TIME OVERCURRENT CHARACTERISTIC CURVES

TABLE OF CONTENTS

APPENDIX A • TIME OVERCURRENT CHARACTERISTIC CURVES	A-1
EXPLANATION OF CURVES.....	A-1

Figures

Figure A-1. Timing Type B1, Short Inverse	A-3
Figure A-2. Timing Type B1, Short Inverse with Extended Timing Range.....	A-3
Figure A-3. Timing Type B2, Long Inverse.....	A-4
Figure A-4. Timing Type B2, Long Inverse with Extended Timing Range	A-4
Figure A-5. Timing Type B3, Definite Time	A-5
Figure A-6. Timing Type B3, Definite Time with Extended Timing Range.....	A-5
Figure A-7. Timing Type B4, Moderately Inverse.....	A-6
Figure A-8. Timing Type B4, Moderately Inverse with Extended Timing Range	A-6
Figure A-9. Timing Type B5, Inverse.....	A-7
Figure A-10. Timing Type B5, Inverse with Extended Timing Range	A-7
Figure A-11. Timing Type B6, Very Inverse	A-8
Figure A-12. Timing Type B6, Very Inverse with Extended Timing Range.....	A-8
Figure A-13. Timing Type B7, Extremely Inverse.....	A-9
Figure A-14. Timing Type B7, Extremely Inverse with Extended Timing Range	A-9
Figure A-15. Timing Type B8, I^2t	A-10
Figure A-16. Timing Type B8, I^2t with Extended Timing Range	A-10
Figure A-17. Timing Type C1, I^2t with Limit #1	A-11
Figure A-18. Timing Type C1, I^2t with Limit #1 and Extended Timing Range	A-11
Figure A-19. Timing Type C2, I^2t with Limit #2	A-12
Figure A-20. Timing Type C2, I^2t with Limit #2 and Extended Timing Range	A-12
Figure A-21. Timing Type C3, I^2t with Limit #3	A-13
Figure A-22. Timing Type C3, I^2t with Limit #3 and Extended Timing Range	A-13
Figure A-23. Timing Type C4, I^2t with Limit #4	A-14
Figure A-24. Timing Type C4, I^2t with Limit #4 and Extended Timing Range	A-14
Figure A-25. Timing Type C5, I^2t with Limit #5	A-15
Figure A-26. Timing Type C5, I^2t with Limit #5 and Extended Timing Range	A-15
Figure A-27. Timing Type C6, I^2t with Limit #6	A-16
Figure A-28. Timing Type C6, I^2t with Limit #6 and Extended Timing Range	A-16
Figure A-29. Timing Type C7, I^2t with Limit #7	A-17
Figure A-30. Timing Type C7, I^2t with Limit #7 and Extended Timing Range	A-17
Figure A-31. Timing Type C8, I^2t with Limit #8	A-18
Figure A-32. Timing Type C8, I^2t with Limit #8 and Extended Timing Range	A-18
Figure A-33. Timing Type E2, BS 142 Long Inverse.....	A-19
Figure A-34. Timing Type E4, BS 142 Inverse.....	A-19
Figure A-35. Timing Type E5, BS 142 Inverse.....	A-20
Figure A-36. Timing Type E6, BS 142 Very Inverse	A-20
Figure A-37. Timing Type E7, BS 142 Extremely Inverse.....	A-21
Figure A-38. Timing Type B1, Short Inverse with Integrated Algorithm.....	A-22
Figure A-39. Timing Type B1, Short Inverse with Integrated Algorithm and Extended Timing.....	A-22
Figure A-40. Timing Type B2, Long Inverse with Integrated Algorithm.....	A-23
Figure A-41. Timing Type B2, Long Inverse with Integrated Algorithm and Extended Timing	A-23
Figure A-42. Timing Type B3, Definite Time with Integrated Algorithm	A-24
Figure A-43. Timing Type B3, Definite Time with Integrated Algorithm and Extended Timing.....	A-24
Figure A-44. Timing Type B4, Moderately Inverse with Integrated Algorithm.....	A-25
Figure A-45. Timing Type B4, Moderately Inverse with Integrated Algorithm and Extended Timing	A-25
Figure A-46. Timing Type B5, Inverse with Integrated Algorithm.....	A-26
Figure A-47. Timing Type B5, Inverse with Integrated Algorithm and Extended Timing	A-26
Figure A-48. Timing Type B6, Very Inverse with Integrated Algorithm	A-27

Figure A-49. Timing Type B6, Very Inverse with Integrated Algorithm and Extended Timing	A-27
Figure A-50. Timing Type B7, Extremely Inverse with Integrated Algorithm.....	A-28
Figure A-51. Timing Type B7, Extremely Inverse with Integrated Algorithm and Extended Timing	A-28
Figure A-52. Timing Type B8, I ² t with Integrated Algorithm.....	A-29
Figure A-53. Timing Type B8, I ² t with Integrated Algorithm and Extended Timing	A-29
Figure A-54. Timing Type C1, I ² t Limit #1 with Integrated Algorithm.....	A-30
Figure A-55. Timing Type C1, I ² t Limit #1 with Integrated Algorithm.....	A-30
Figure A-56. Timing Type C2, I ² t Limit #2 with Integrated Algorithm.....	A-31
Figure A-57. Timing Type C2, I ² t Limit #2 with Integrated Algorithm and Extended Timing	A-31
Figure A-58. Timing Type C3, I ² t Limit #3 with Integrated Algorithm.....	A-32
Figure A-59. Timing Type C3, I ² t Limit #3 with Integrated Algorithm and Extended Timing	A-32
Figure A-60. Timing Type C4, I ² t Limit #4 with Integrated Algorithm.....	A-33
Figure A-61. Timing Type C4, I ² t Limit #4 with Integrated Algorithm and Extended Timing	A-33
Figure A-62. Timing Type C5, I ² t Limit #5 with Integrated Algorithm.....	A-34
Figure A-63. Timing Type C5, I ² t Limit #5 with Integrated Algorithm and Extended Timing	A-34
Figure A-64. Timing Type C6, I ² t Limit #6 with Integrated Algorithm.....	A-35
Figure A-65. Timing Type C6, I ² t Limit #6 with Integrated Algorithm and Extended Timing	A-35
Figure A-66. Timing Type C7, I ² t Limit #7 with Integrated Algorithm.....	A-36
Figure A-67. Timing Type C7, I ² t Limit #7 with Integrated Algorithm and Extended Timing	A-36
Figure A-68. Timing Type C8, I ² t Limit #8 with Integrated Algorithm.....	A-37
Figure A-69. Timing Type C8, I ² t Limit #8 with Integrated Algorithm and Extended Timing	A-37

Tables

Table A-1. Timing Choices with Available Curves.....	A-1
Table A-2. Timing Curve Selection Table.....	A-2

APPENDIX A • TIME OVERCURRENT CHARACTERISTIC CURVES

EXPLANATION OF CURVES

Graphs on the following pages illustrate sample characteristic curves for all of the time overcurrent functions individually as options, or selectable by switch (if the Z1, Z2, or Z3 timing option is specified). Z1 option can select any of the timing types designated as B1 through B8, and C1 through C8. Z2 option can select any of the timing types designated as B1 through B8, and the British Standard timing types: E2, E4, E5, E6, and E7. Z3 option can select the integrating algorithm for any of the timing types designated as B1 through B8, and C1 through C8.

Note that there are two versions of each timing type: standard and extended timing. Both types are located on the same page. The exception to this is the British Standard curves, which do not have an extended timing version. For any given relay, either the standard or the extended range version will apply, never both.

Table A-1 lists timing choices with available curves. Table A-2 lists the positions of the timing curve selector switch. (See Figure 2-1 for switch location).

Table A-1. Timing Choices with Available Curves

Timing Choices	Z1	Z2	Z3 (Integrating)
Available Curves	Short Inverse	Short Inverse	Short Inverse
	Long Inverse	Long Inverse	Long Inverse
	Definite Time	Definite Time	Definite Time
	Moderately Inverse	Moderately Inverse	Moderately Inverse
	Inverse Time	Inverse Time	Inverse Time
	Very Inverse	Very Inverse	Very Inverse
	Extremely Inverse	Extremely Inverse	Extremely Inverse
	I^2t	BS 142 Long Inverse	I^2t
	I^2t with Limit 1	BS142 Inverse	I^2t with Limit 1
	I^2t with Limit 2	BS142 Inverse	I^2t with Limit 2
	I^2t with Limit 3	BS142 Very Inverse	I^2t with Limit 3
	I^2t with Limit 4	BS142 Extremely Inverse	I^2t with Limit 4
	I^2t with Limit 5	N/A	I^2t with Limit 5
	I^2t with Limit 6	N/A	I^2t with Limit 6
	I^2t with Limit 7	N/A	I^2t with Limit 7
	I^2t with Limit 8	N/A	I^2t with Limit 8

Table A-2. Timing Curve Selection Table

Timing Type	Selector Position Z1, Z3	Selector Position Z2	Standard Curves Z1, Z2 Fig. No.	Extended Curves Z1, Z2 Fig. No.	Standard Curves Z3 Fig. No.	Extended Curves Z3 Fig. No.
B1 - Short Inverse	3	3	A-1	A-2	A-38	A-39
B2 - Long Inverse	1	1	A-3	A-4	A-40	A-41
B3 - Definite Time	5	5	A-5	A-6	A-42	A-43
B4 - Moderately Inverse	2	2	A-7	A-8	A-44	A-45
B5 - Inverse	4	4	A-9	A-10	A-46	A-47
B6 - Very Inverse	6	6	A-11	A-12	A-48	A-49
B7 - Extremely Inverse	7	7	A-13	A-14	A-50	A-51
B8 - I ² t	0	0	A-15	A-16	A-52	A-53
C1 - I ² t with Limit #1	8	—	A-17	A-18	A-54	A-55
C2 - I ² t with Limit #2	9	—	A-19	A-20	A-56	A-57
C3 - I ² t with Limit #3	A	—	A-21	A-22	A-58	A-59
C4 - I ² t with Limit #4	B	—	A-23	A-24	A-60	A-61
C5 - I ² t with Limit #5	C	—	A-25	A-26	A-62	A-63
C6 - I ² t with Limit #6	D	—	A-27	A-28	A-64	A-65
C7 - I ² t with Limit #7	E	—	A-29	A-30	A-66	A-67
C8 - I ² t with Limit #8	F	—	A-31	A-32	A-68	A-69
E2 - Long Inverse	—	8	A-33	—	—	—
E4 - Inverse	—	9	A-34	—	—	—
E5 - Inverse	—	A	A-35	—	—	—
E6 - Very Inverse	—	B	A-36	—	—	—
E7 - Extremely Inverse	—	C,D,E,F	A-37	—	—	—

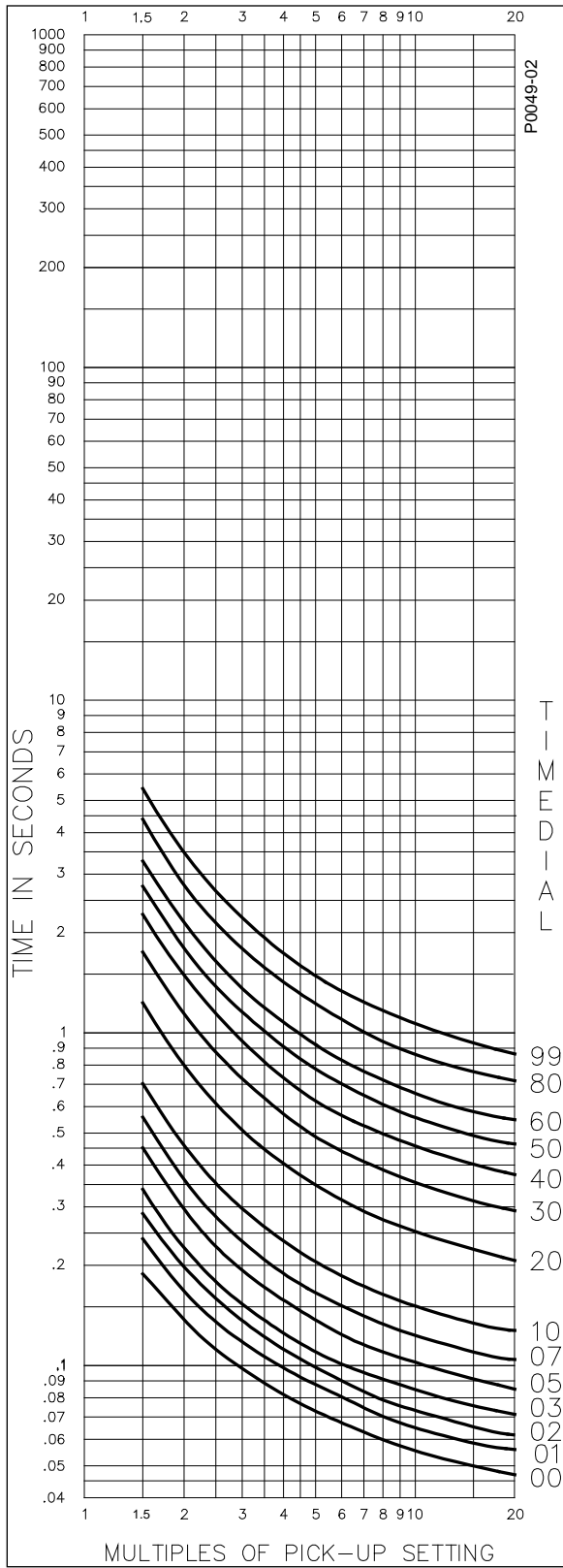

Figure A-1. Timing Type B1, Short Inverse

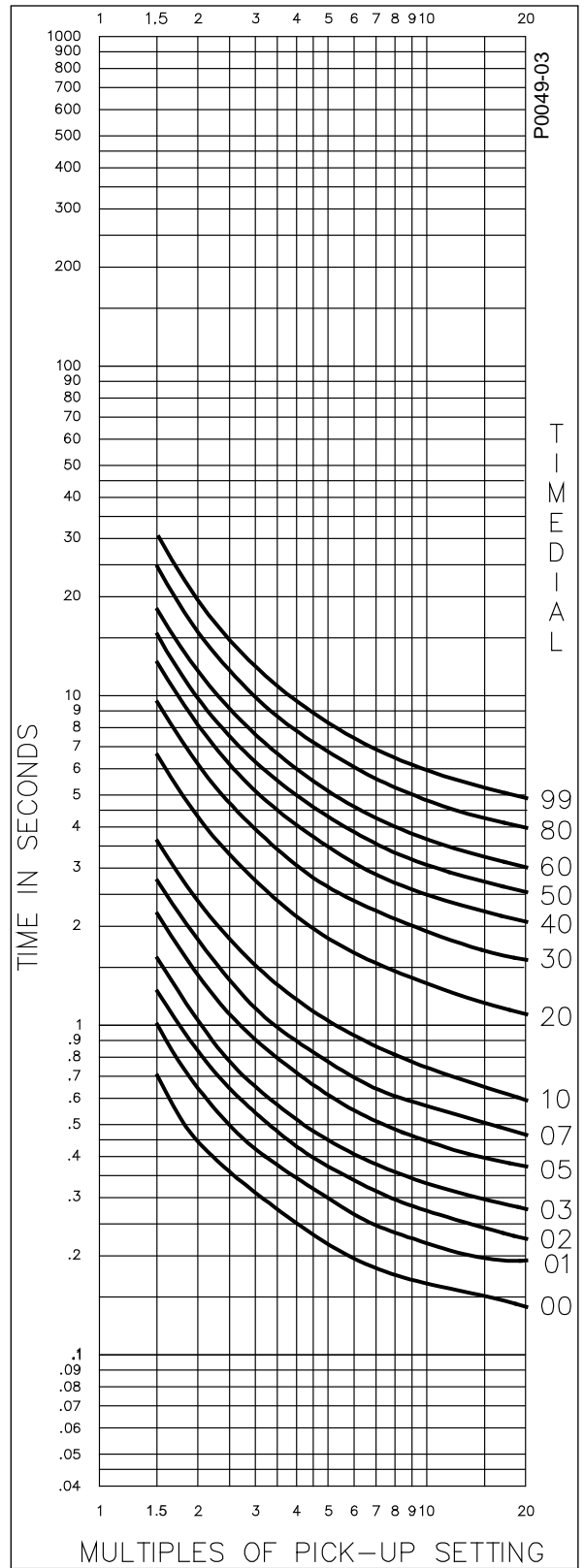

Figure A-2. Timing Type B1, Short Inverse with Extended Timing Range

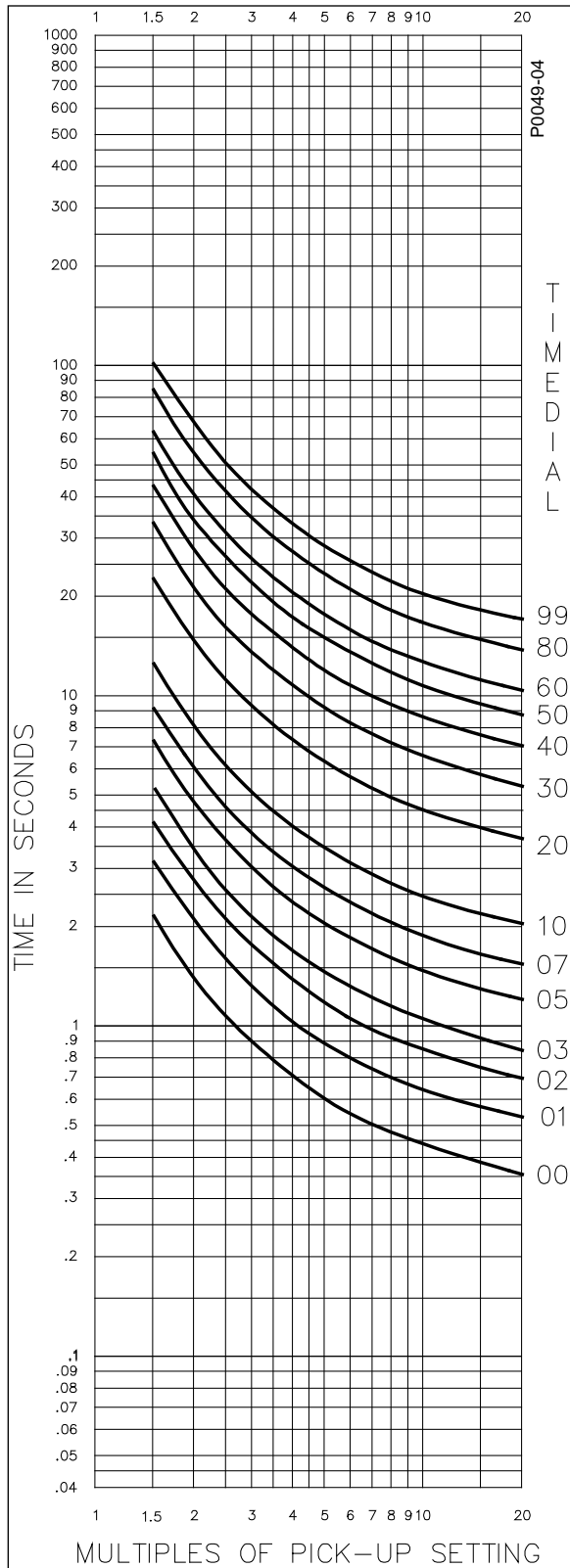

Figure A-3. Timing Type B2, Long Inverse

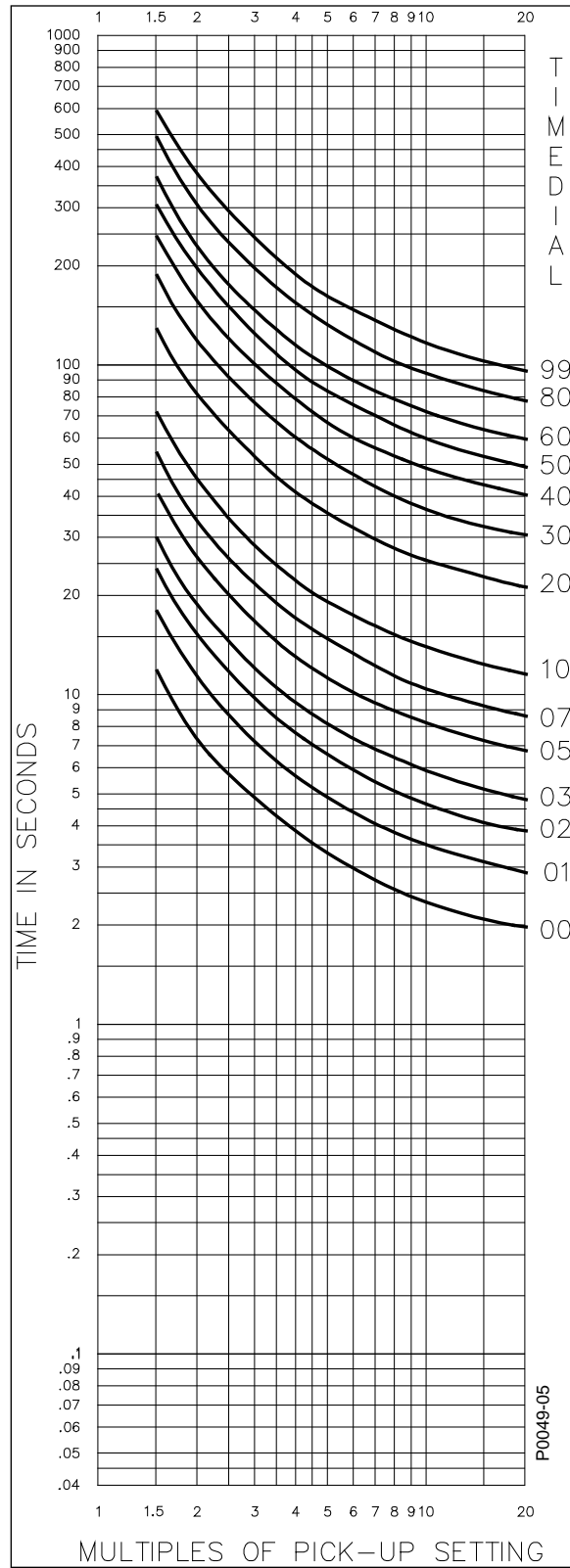

Figure A-4. Timing Type B2, Long Inverse with Extended Timing Range

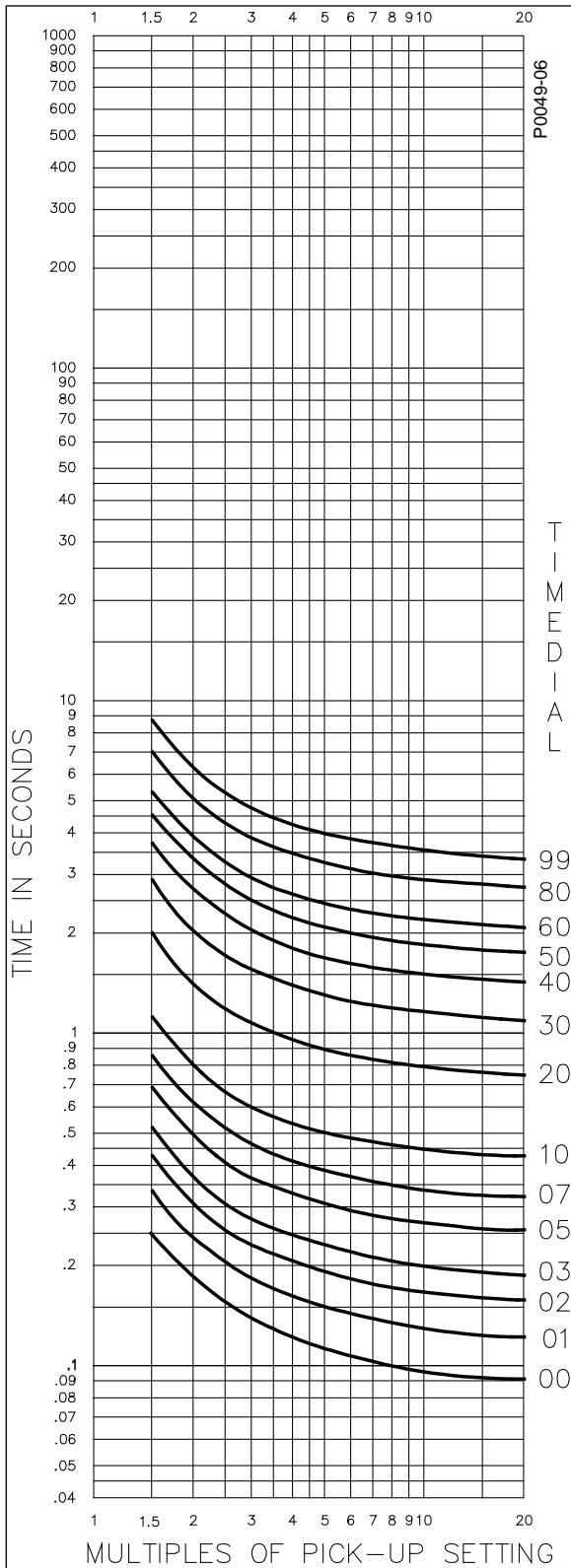

Figure A-5. Timing Type B3, Definite Time

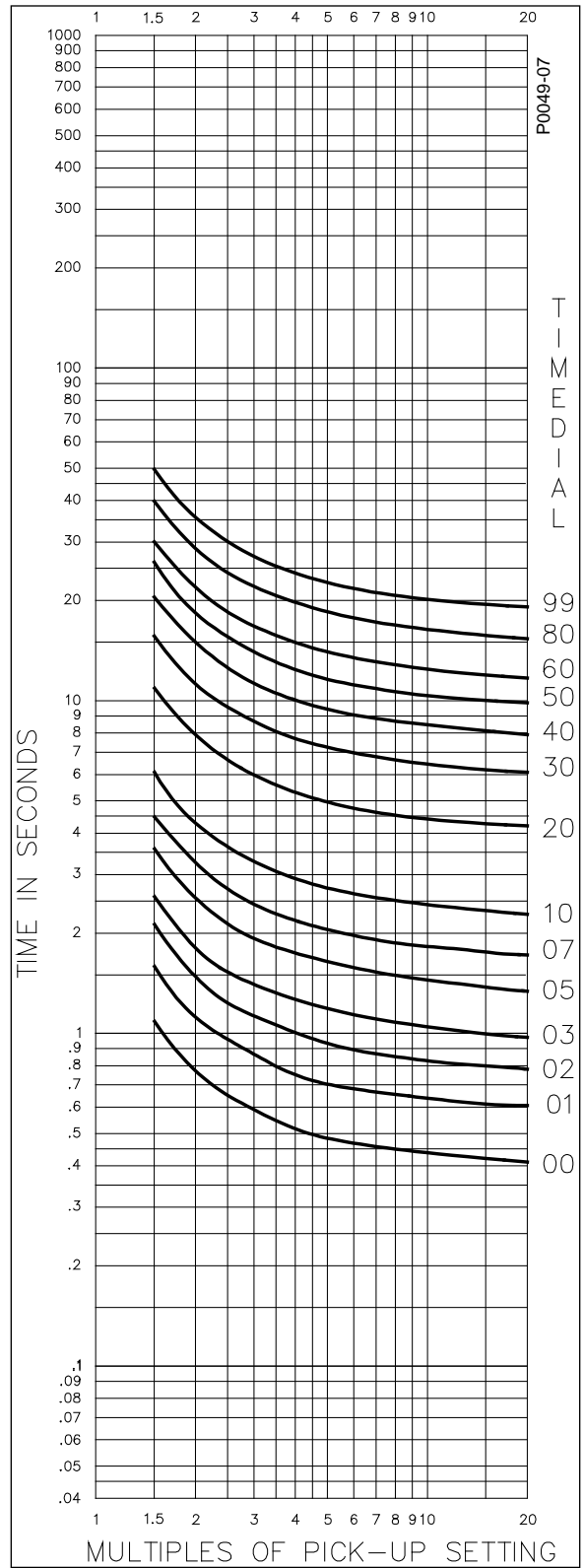

Figure A-6. Timing Type B3, Definite Time with Extended Timing Range

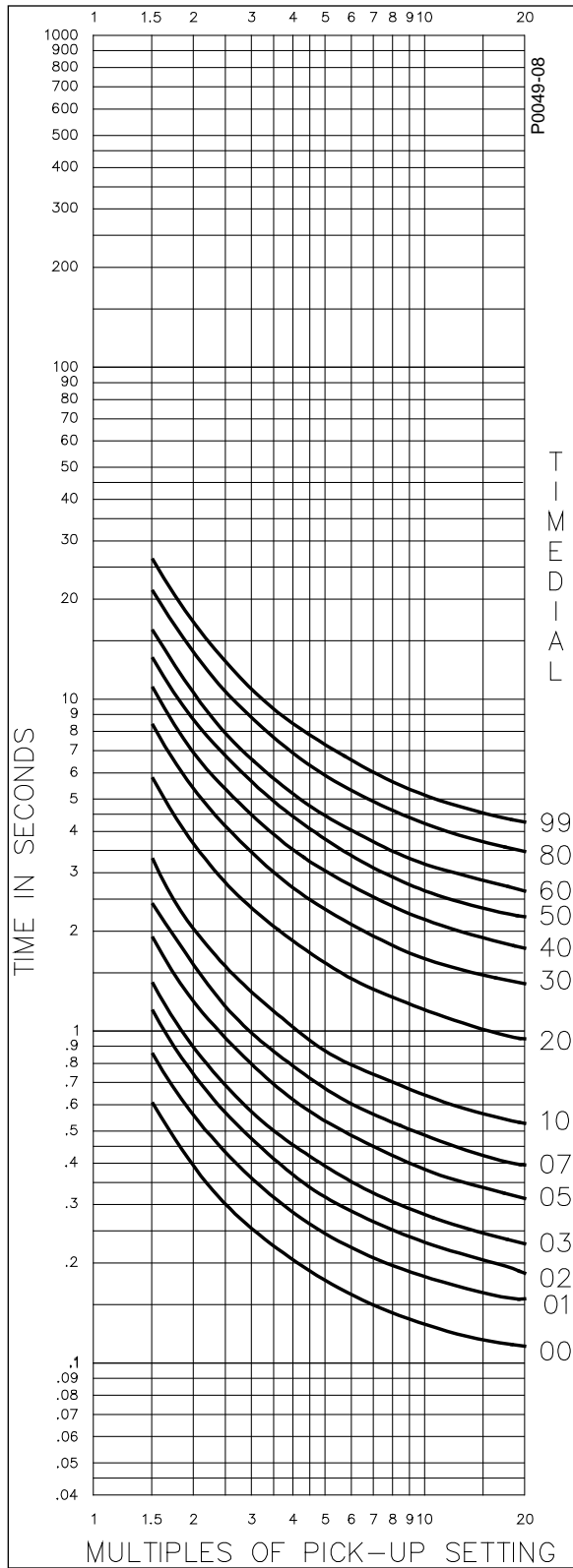

Figure A-7. Timing Type B4, Moderately Inverse

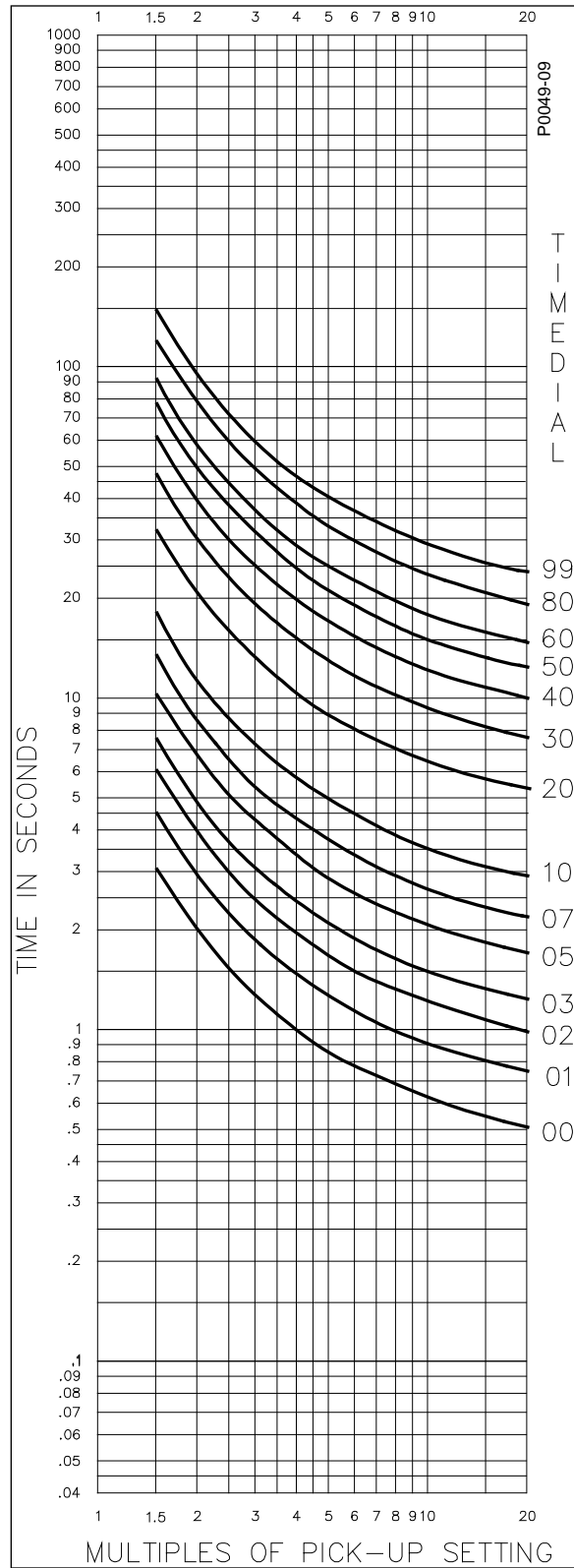

Figure A-8. Timing Type B4, Moderately Inverse with Extended Timing Range

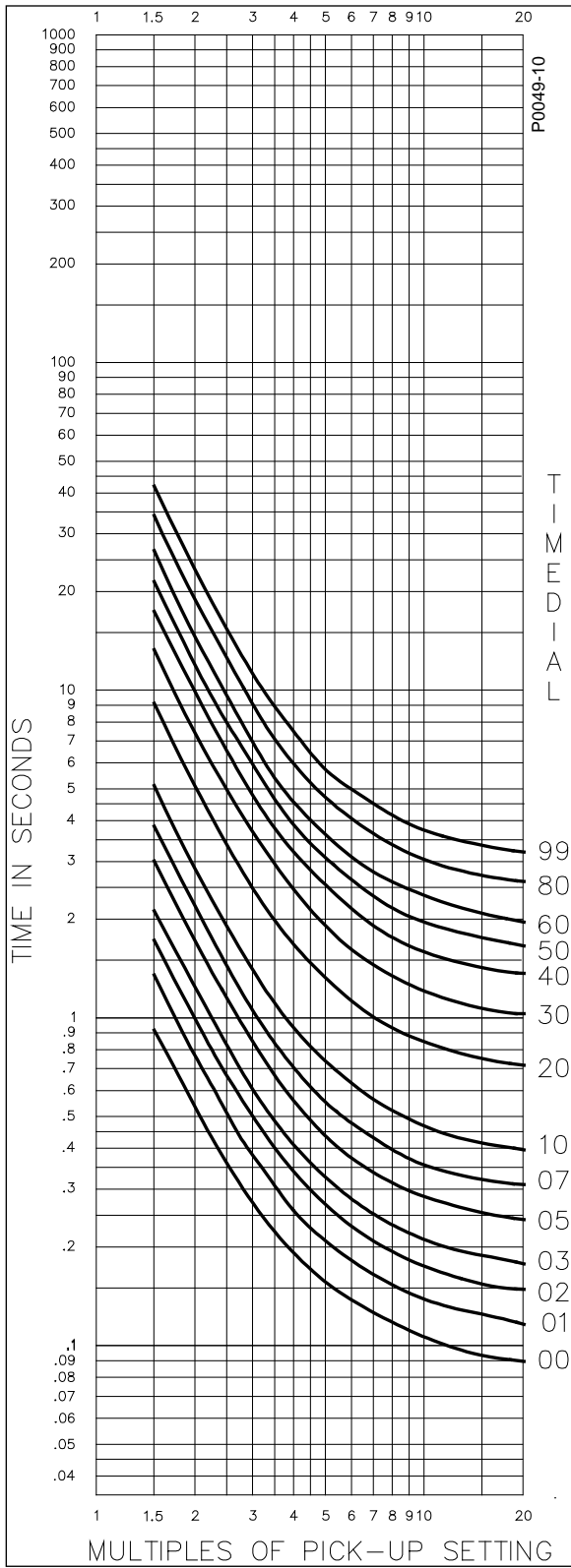

Figure A-9. Timing Type B5, Inverse

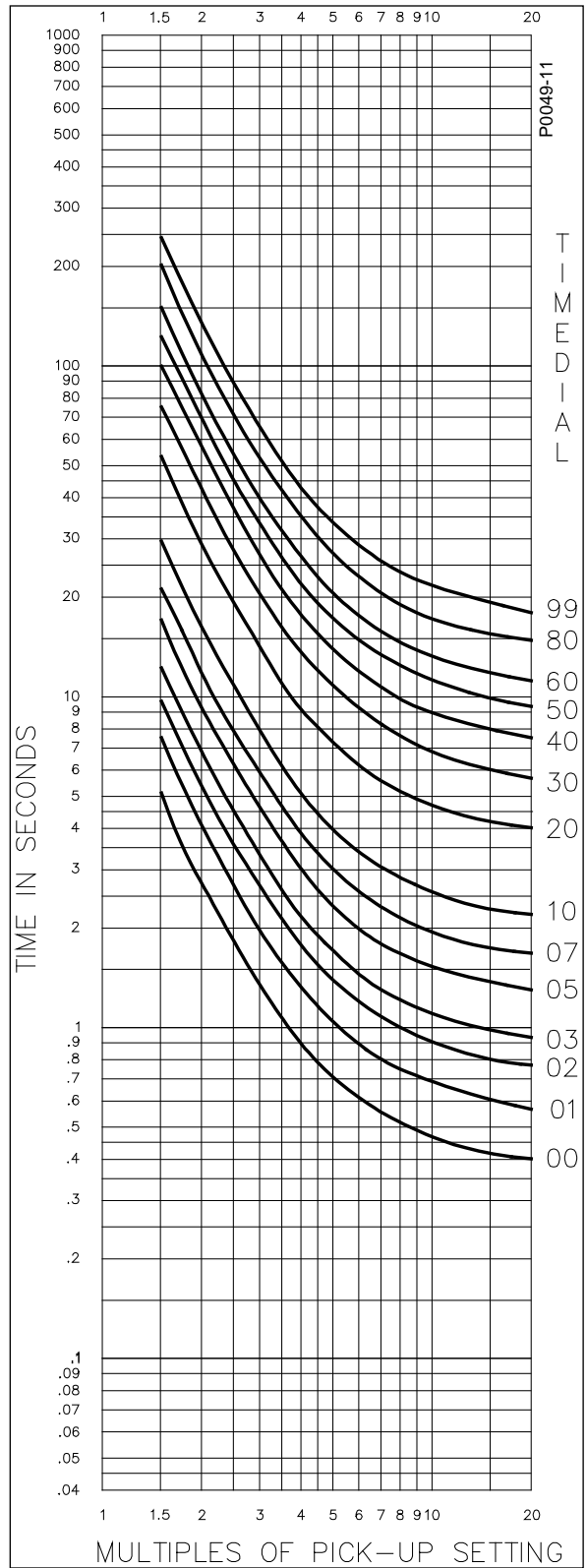

Figure A-10. Timing Type B5, Inverse with Extended Timing Range

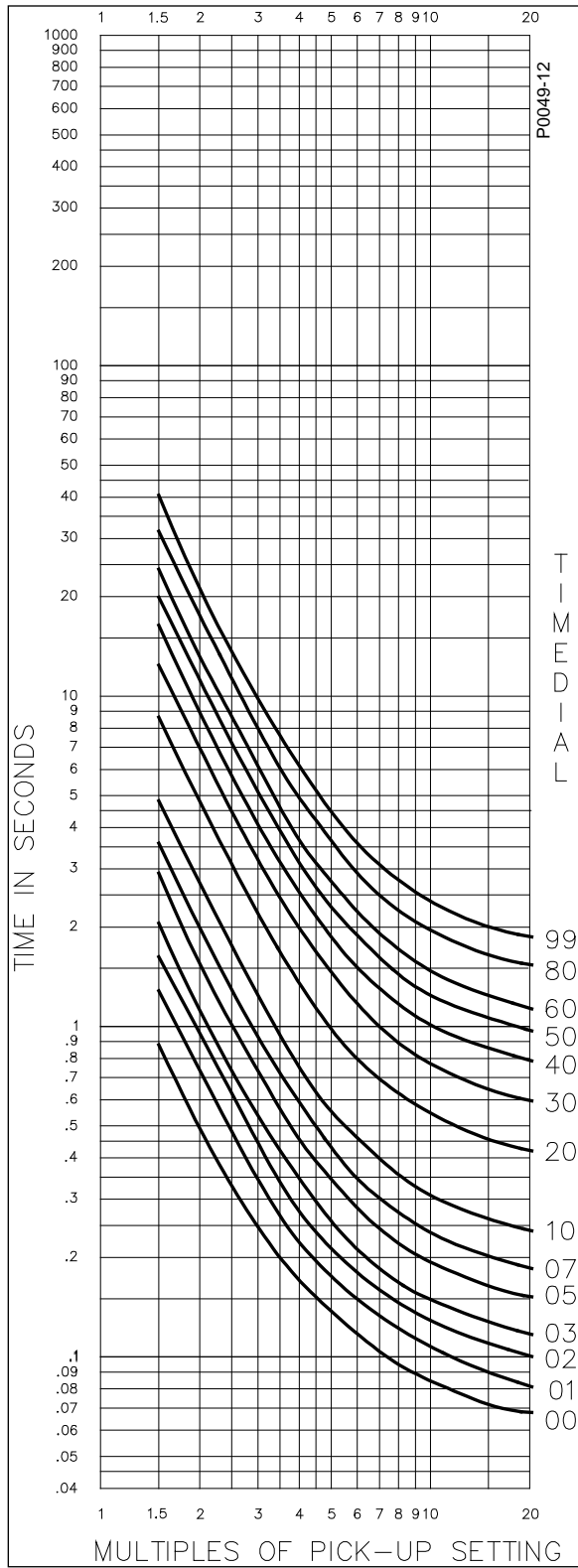

Figure A-11. Timing Type B6, Very Inverse

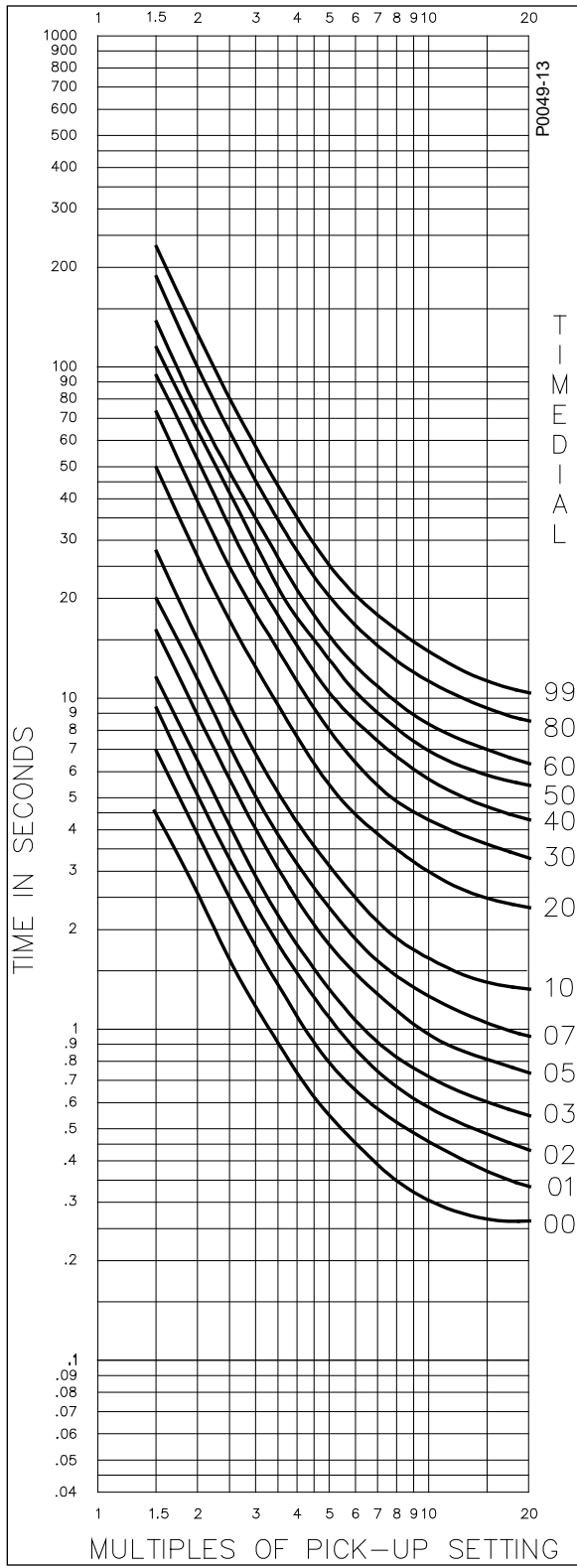

Figure A-12. Timing Type B6, Very Inverse with Extended Timing Range

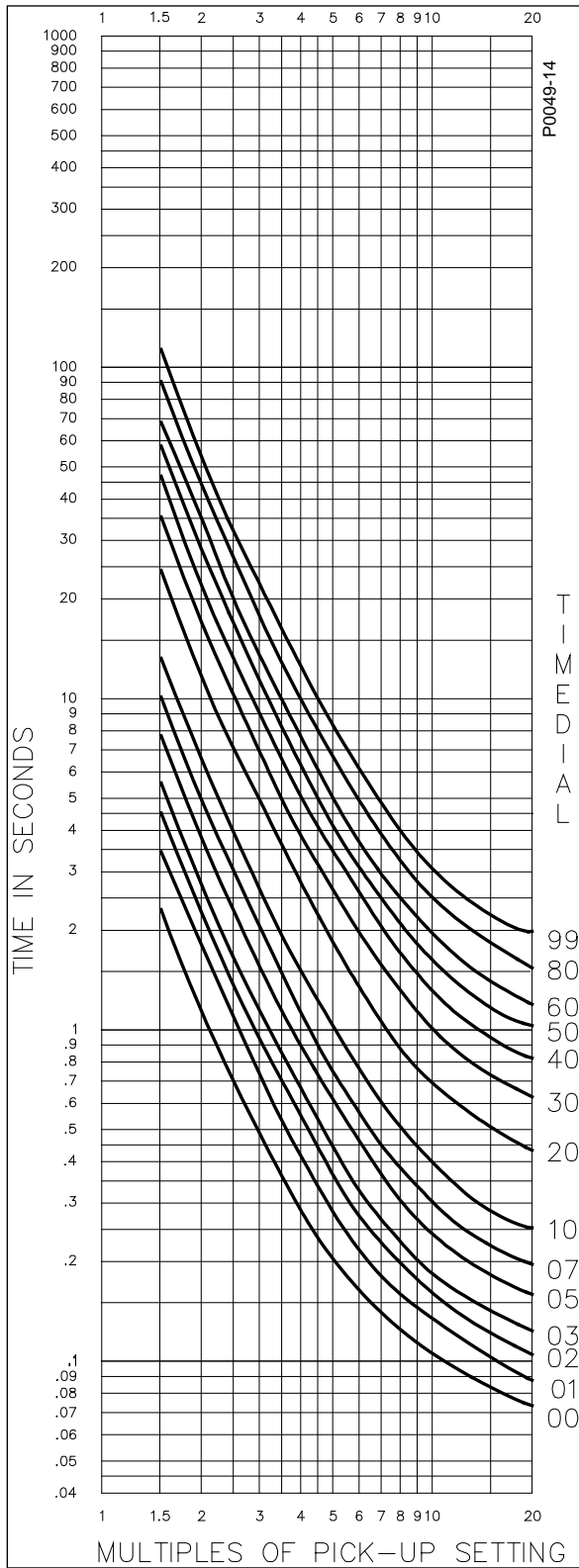

Figure A-13. Timing Type B7, Extremely Inverse

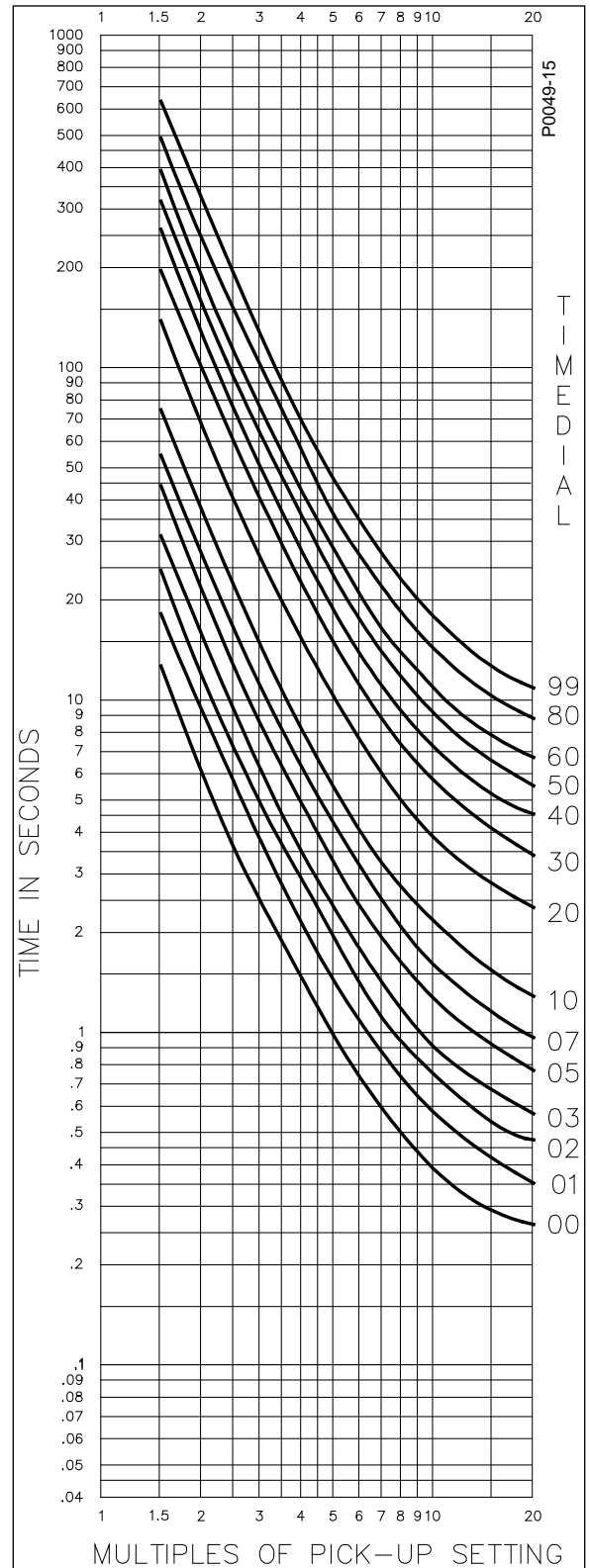

Figure A-14. Timing Type B7, Extremely Inverse with Extended Timing Range

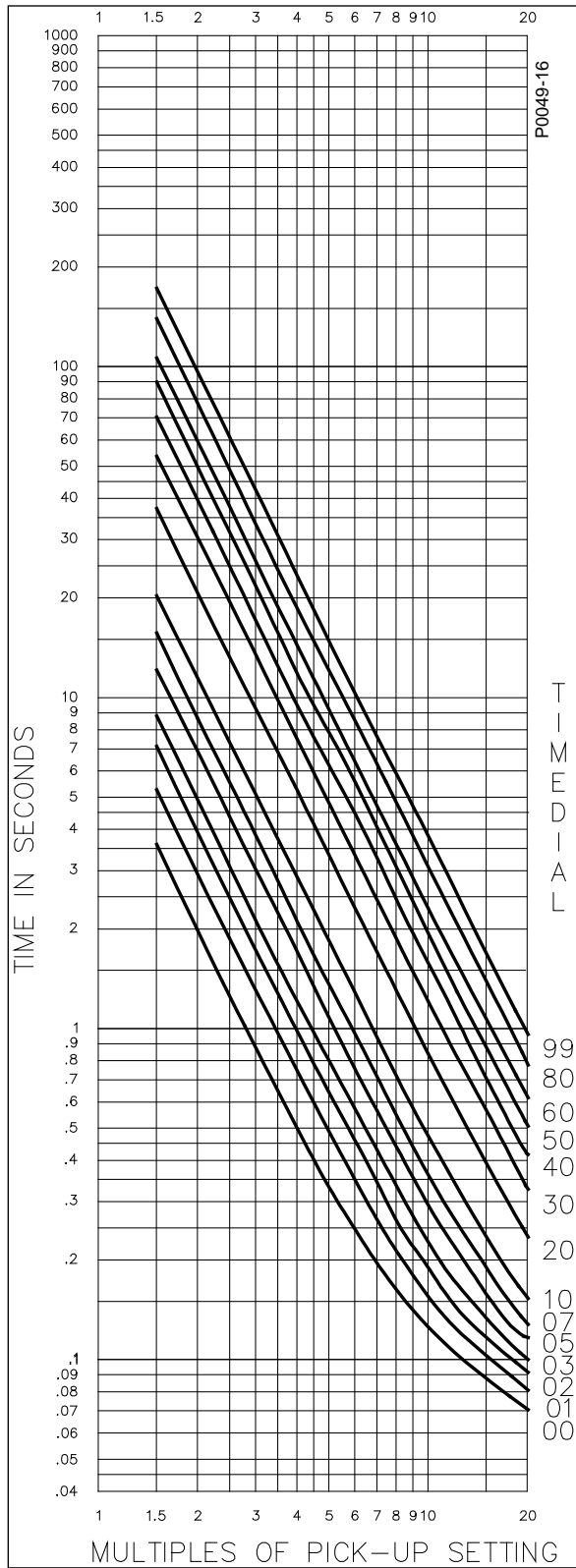

Figure A-15. Timing Type B8, I^2t

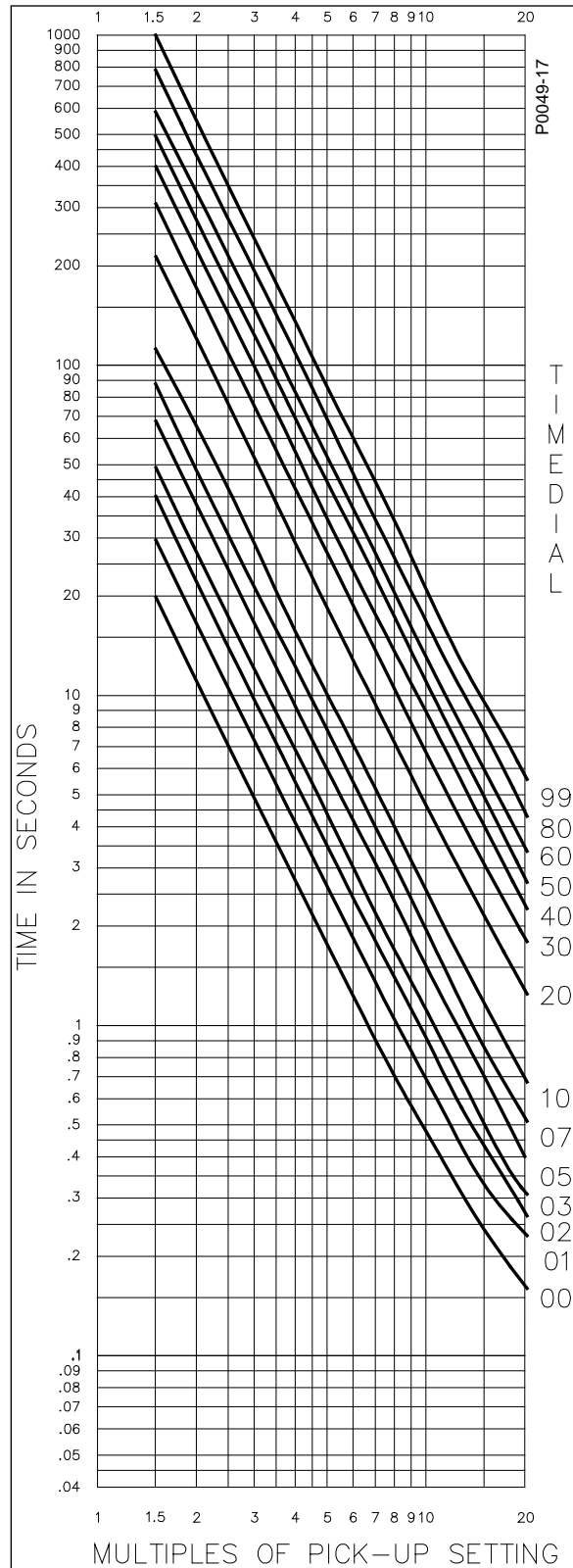

Figure A-16. Timing Type B8, I^2t with Extended Timing Range

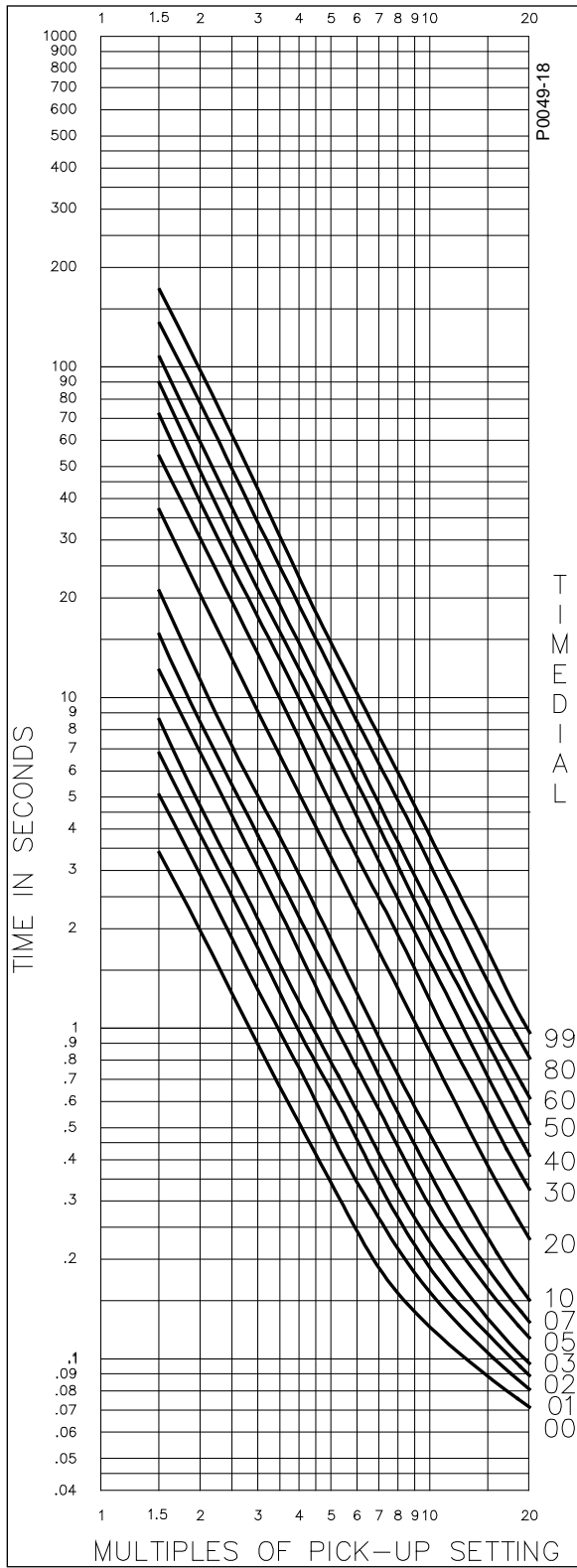

Figure A-17. Timing Type C1, I^2t with Limit #1

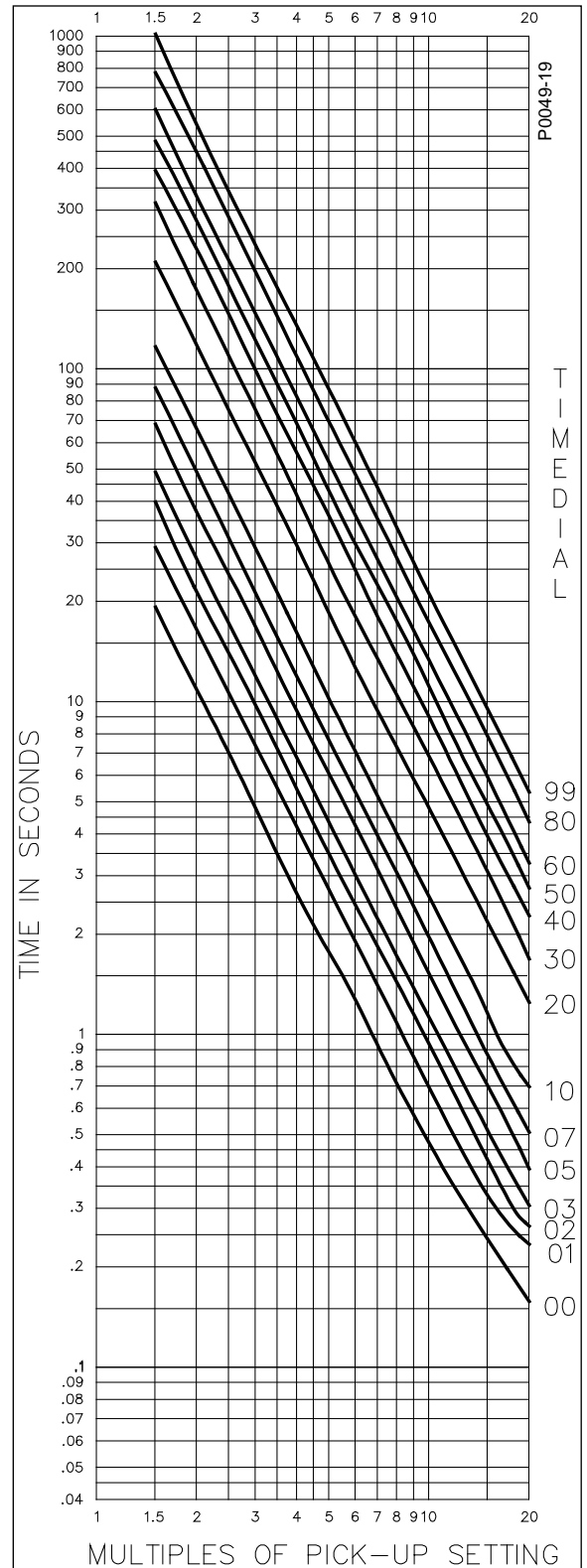

Figure A-18. Timing Type C1, I^2t with Limit #1 and Extended Timing Range

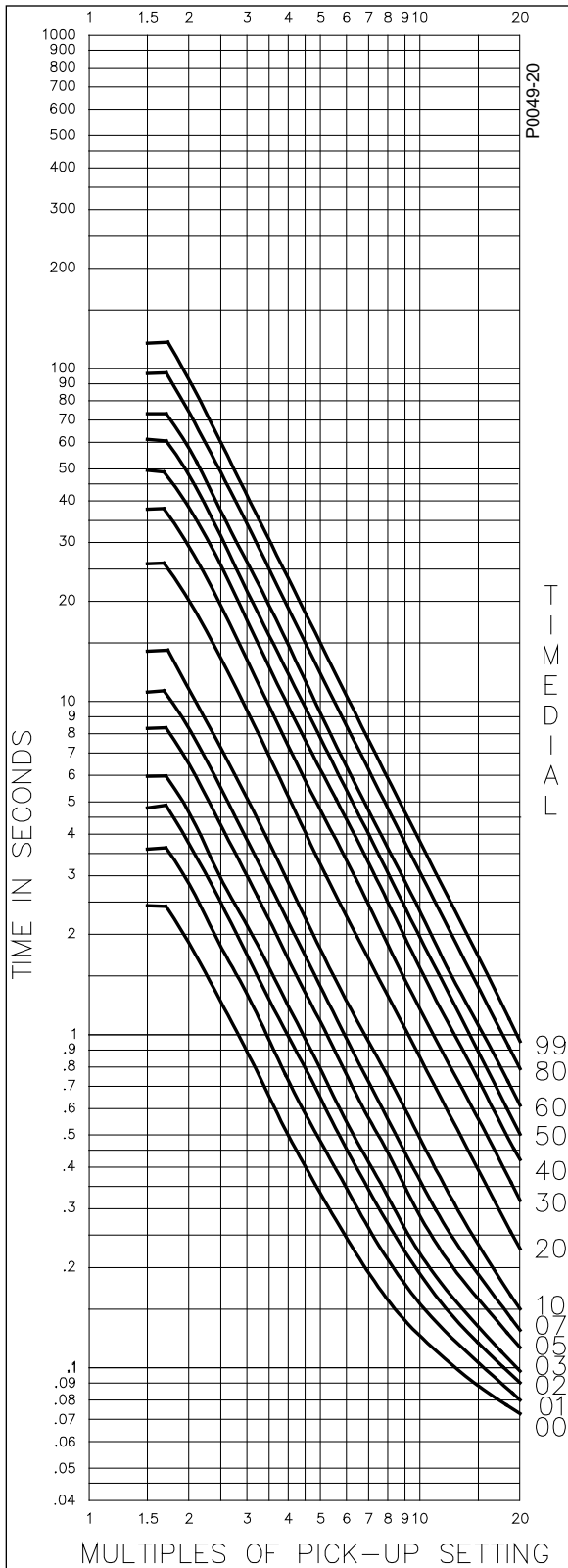

Figure A-19. Timing Type C2, I^2t with Limit #2

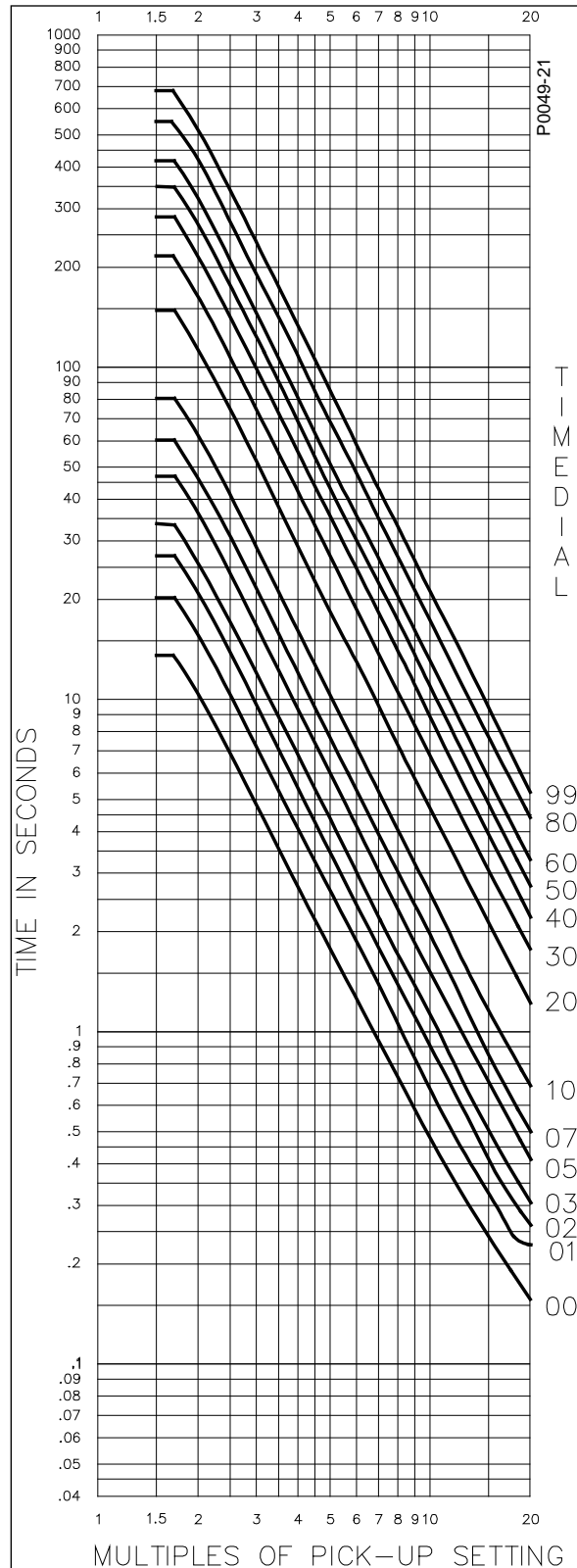

Figure A-20. Timing Type C2, I^2t with Limit #2 and Extended Timing Range

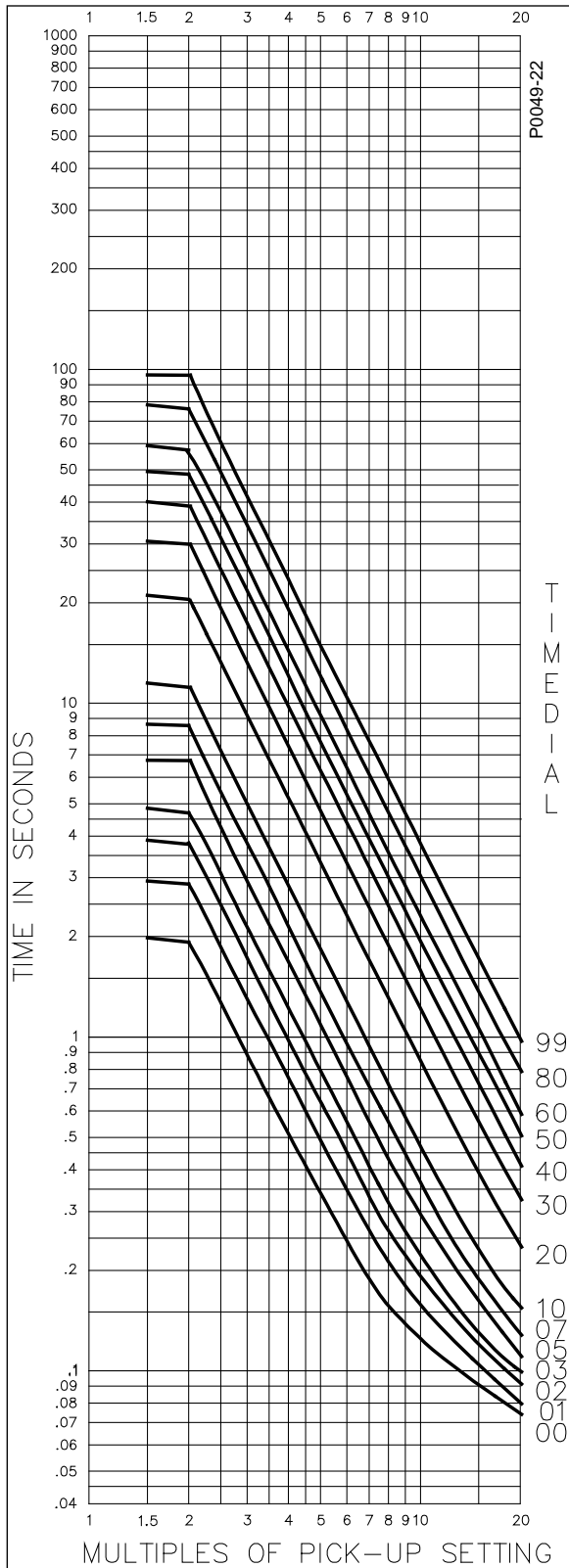

Figure A-21. Timing Type C3, I^2t with Limit #3

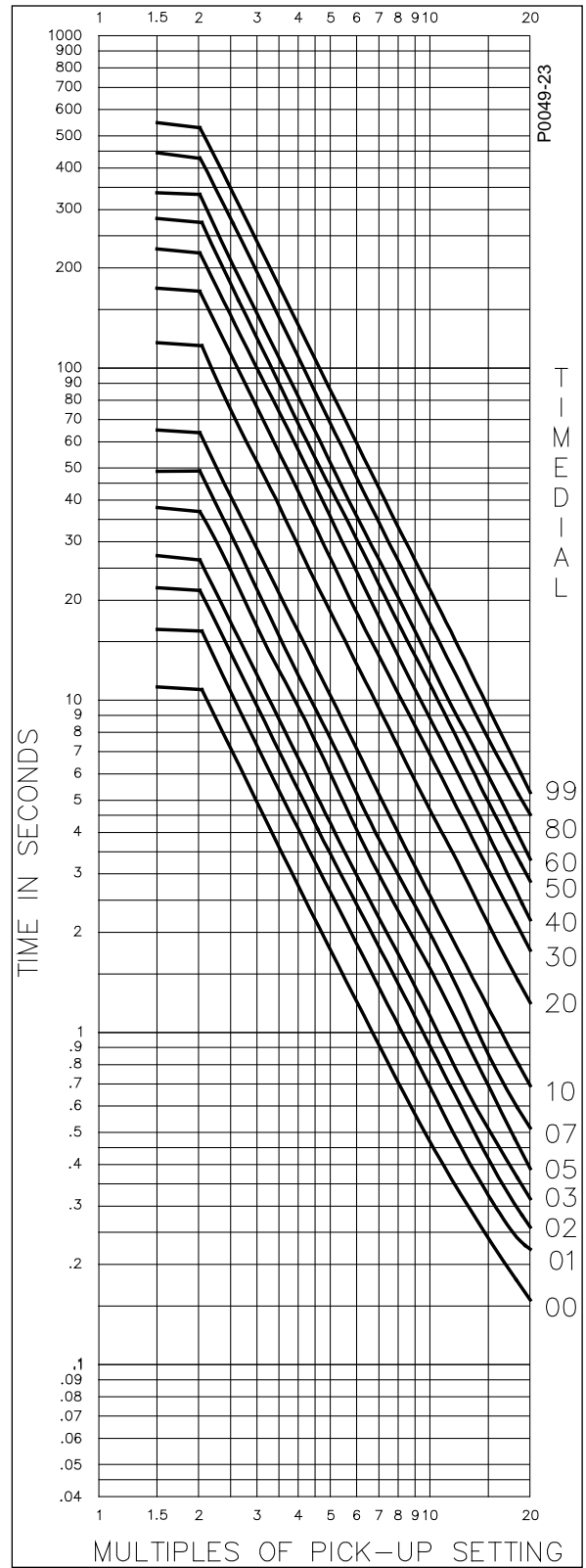

Figure A-22. Timing Type C3, I^2t with Limit #3 and Extended Timing Range

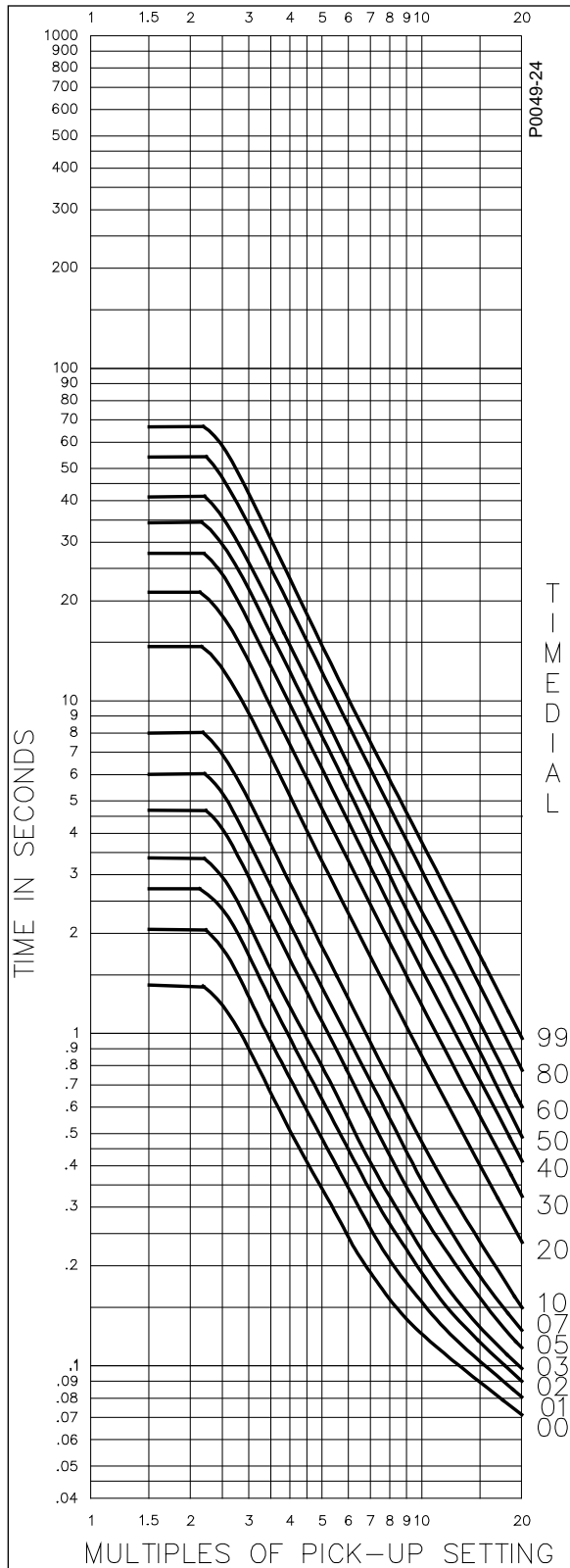

Figure A-23. Timing Type C4, I^2t with Limit #4

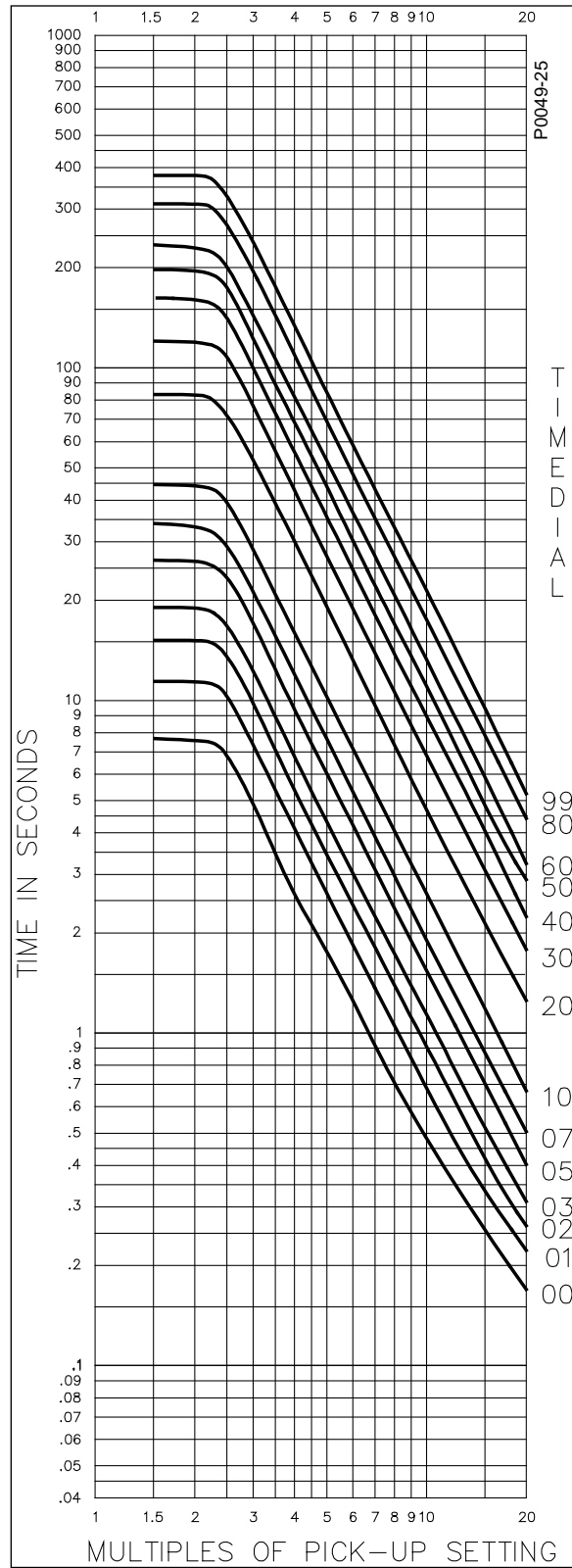

Figure A-24. Timing Type C4, I^2t with Limit #4 and Extended Timing Range

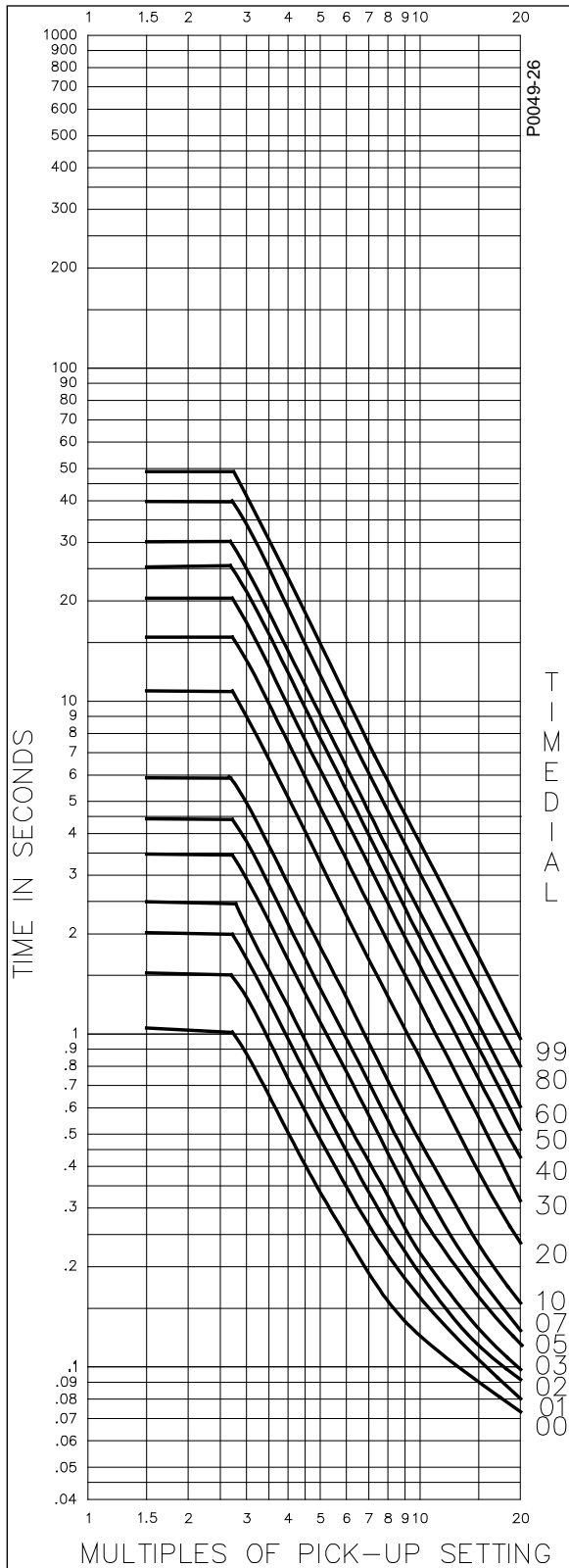

Figure A-25. Timing Type C5, I^2t with Limit #5

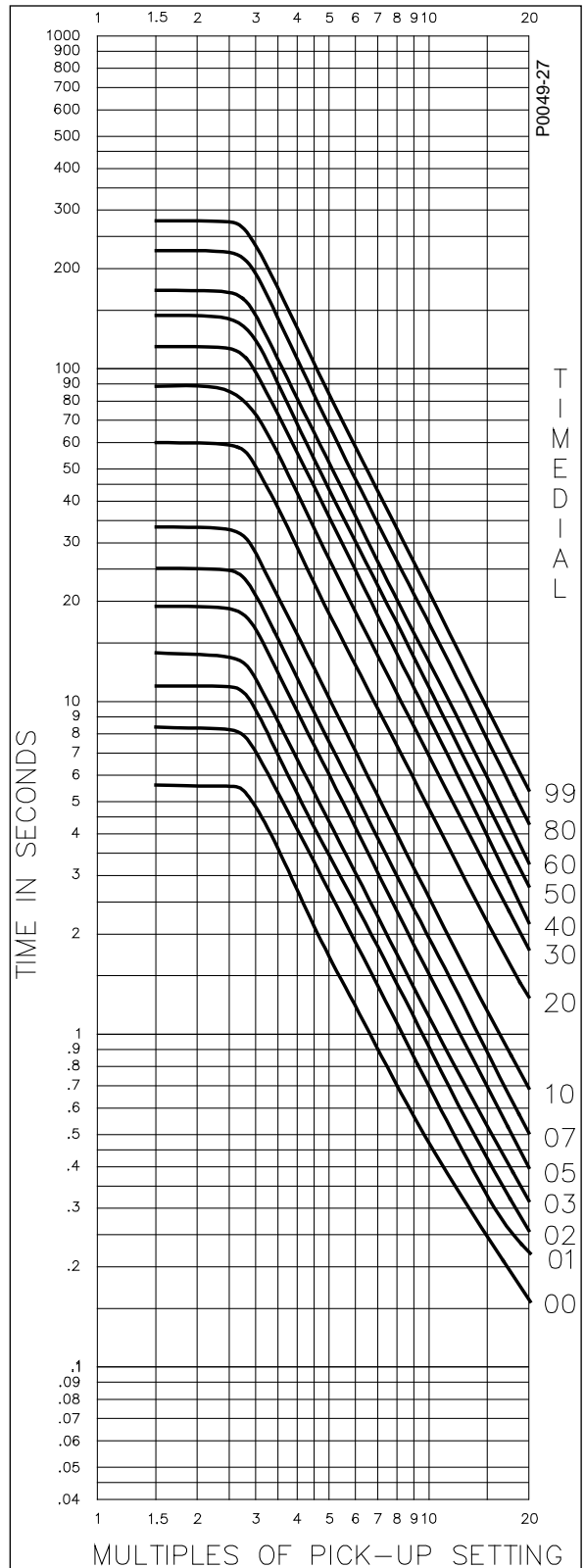

Figure A-26. Timing Type C5, I^2t with Limit #5 and Extended Timing Range

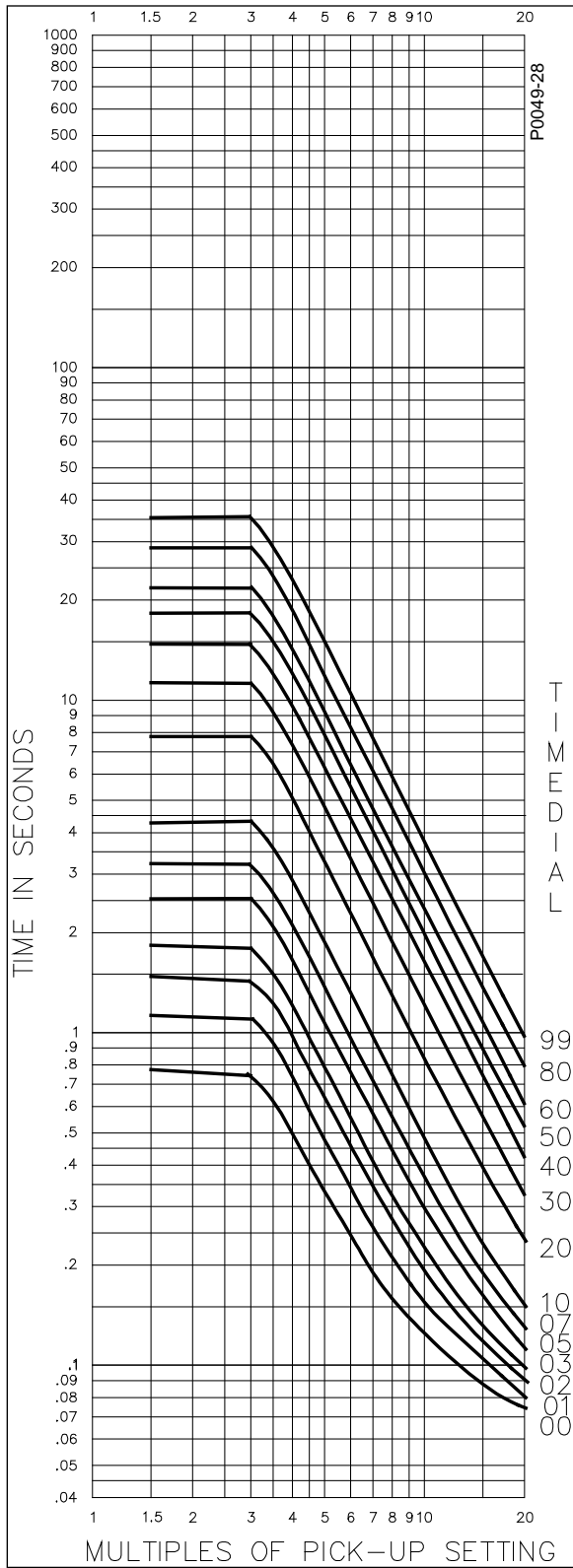

Figure A-27. Timing Type C6, I^2t with Limit #6

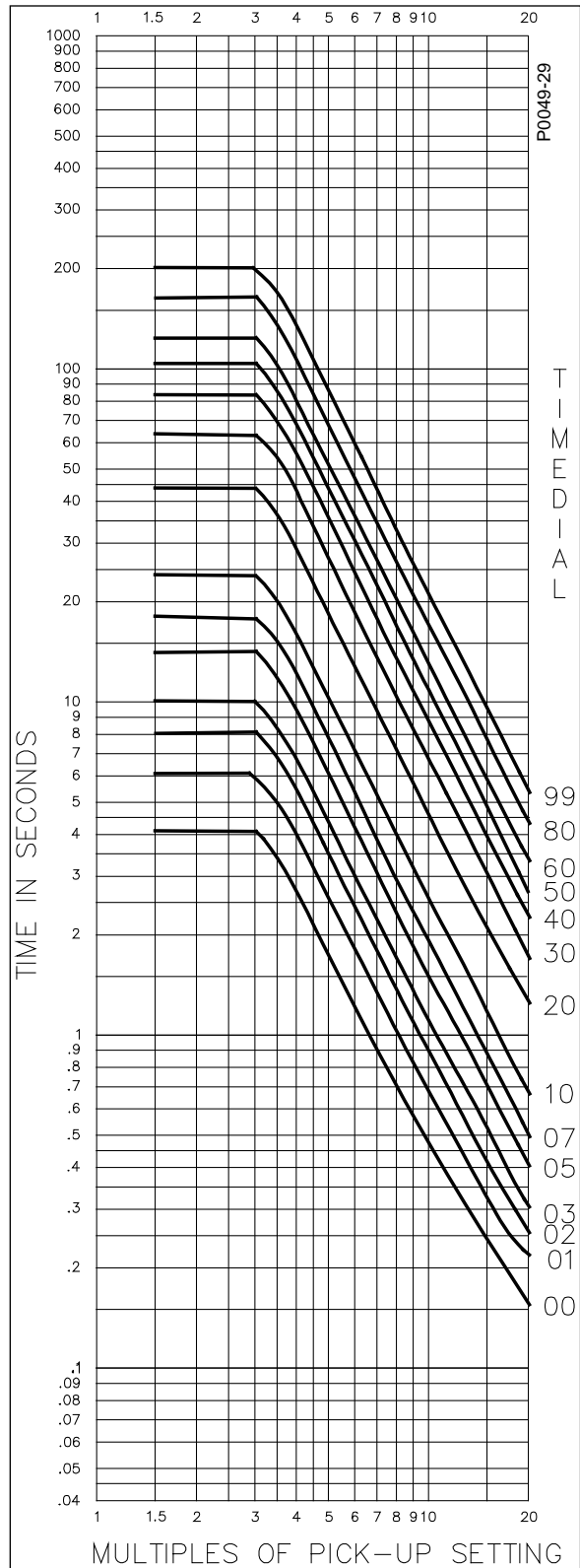

Figure A-28. Timing Type C6, I^2t with Limit #6 and Extended Timing Range

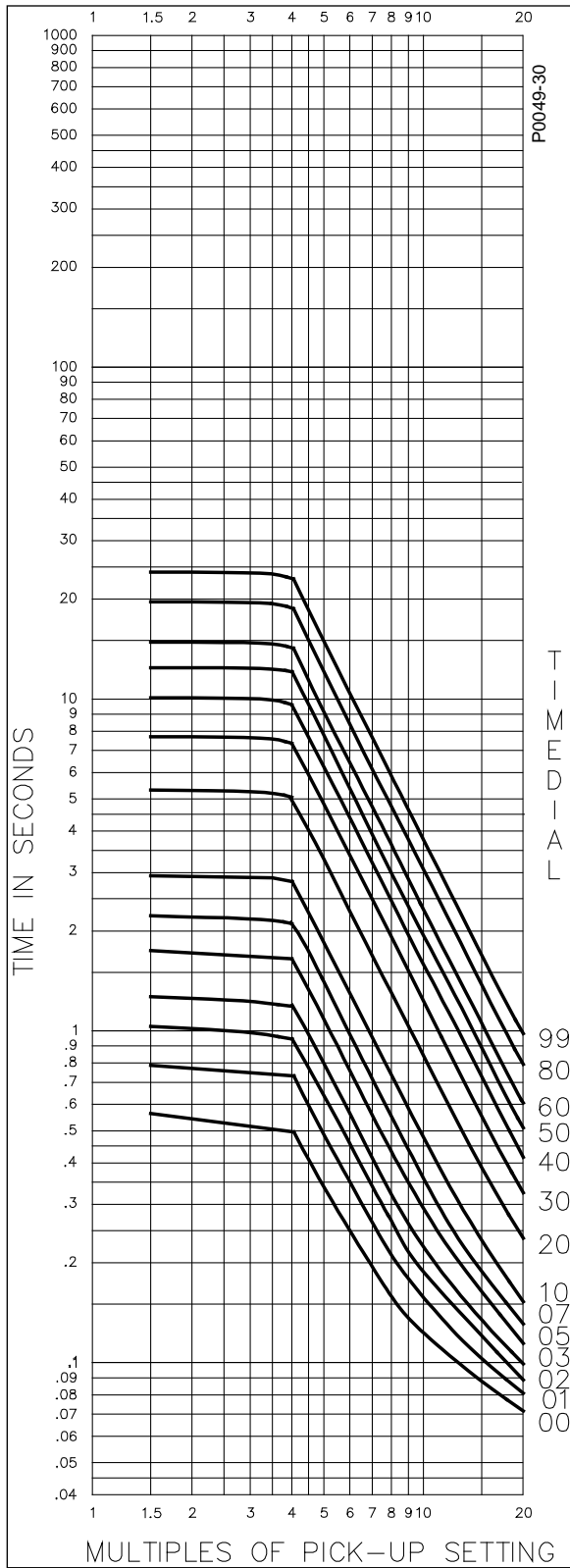

Figure A-29. Timing Type C7, I^2t with Limit #7

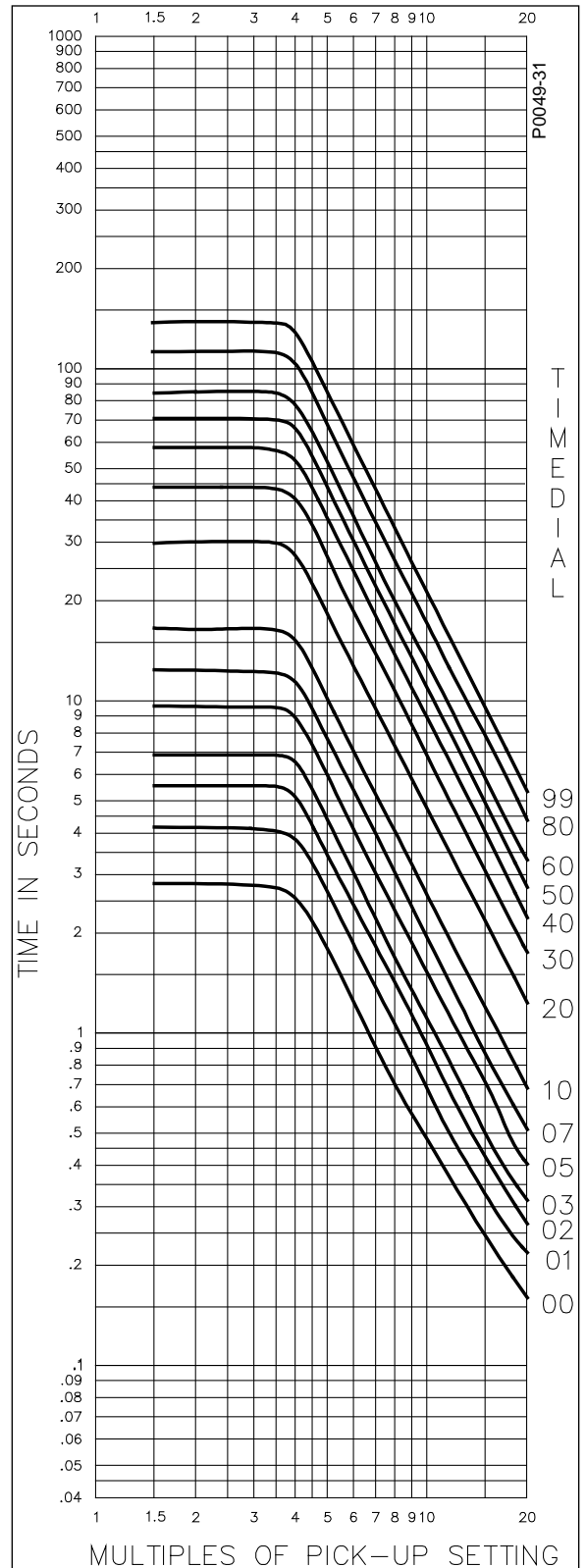

Figure A-30. Timing Type C7, I^2t with Limit #7 and Extended Timing Range

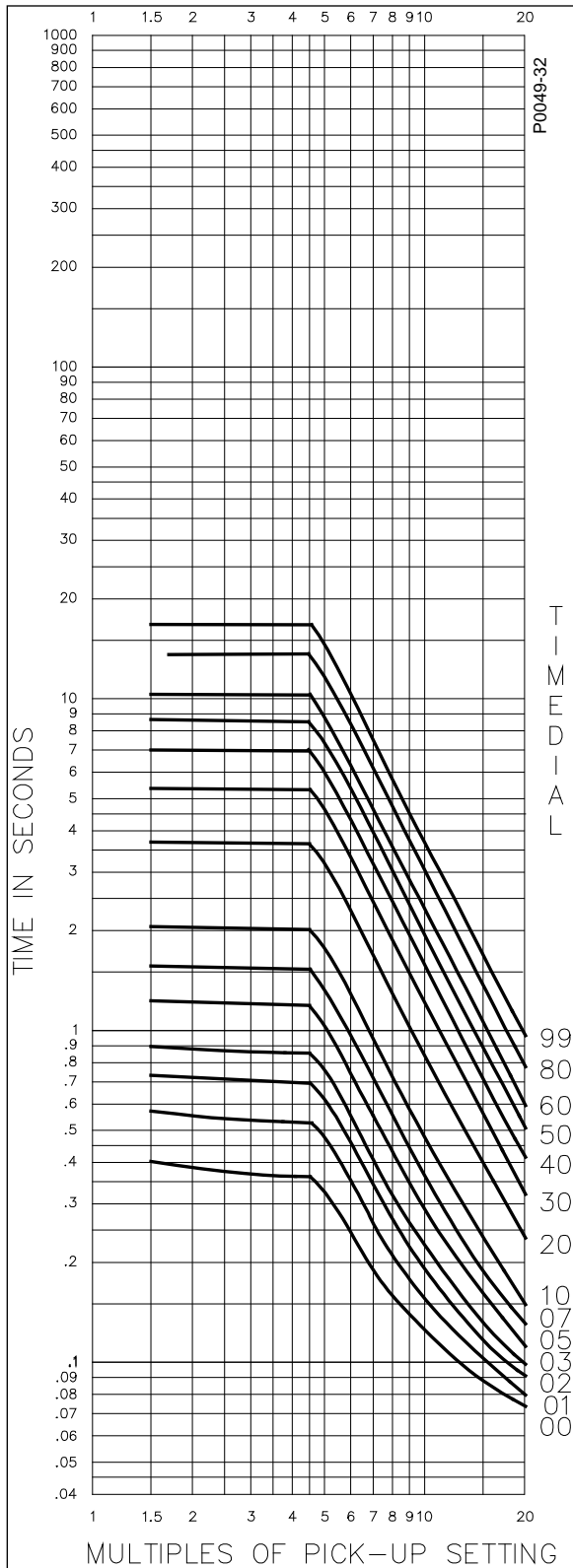

Figure A-31. Timing Type C8, I^2t with Limit #8

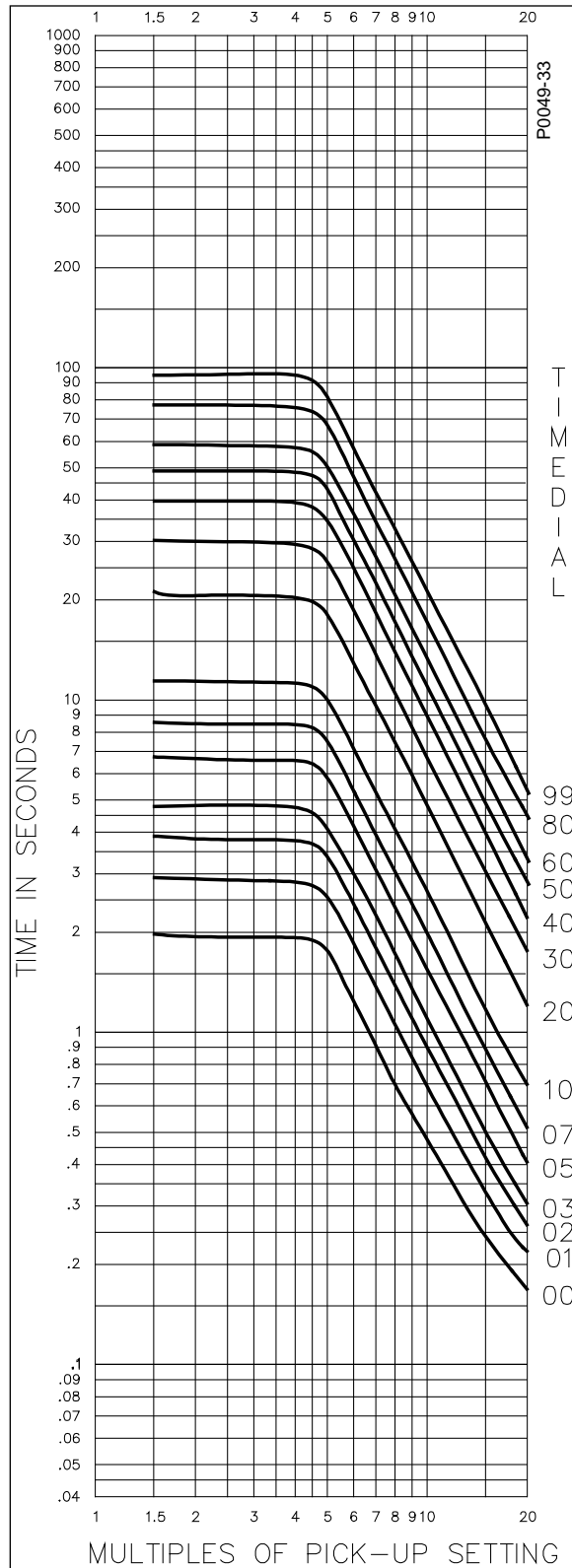

Figure A-32. Timing Type C8, I^2t with Limit #8 and Extended Timing Range

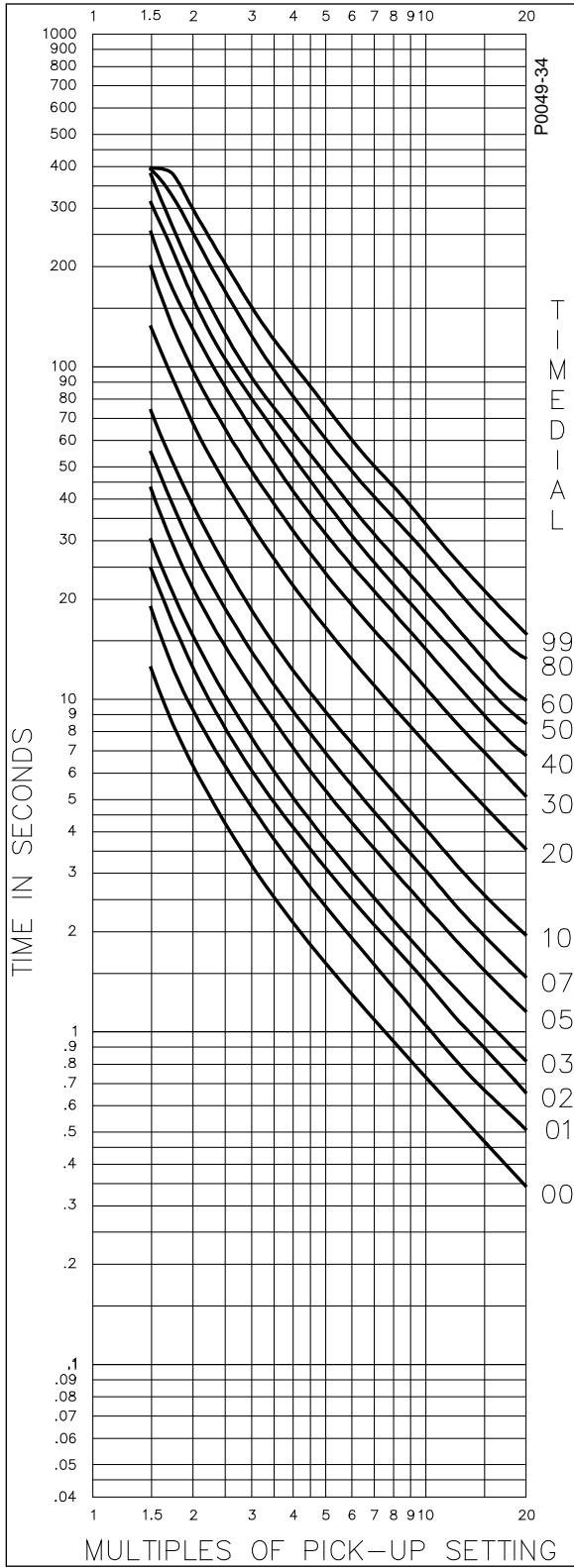

Figure A-33. Timing Type E2,
BS 142 Long Inverse

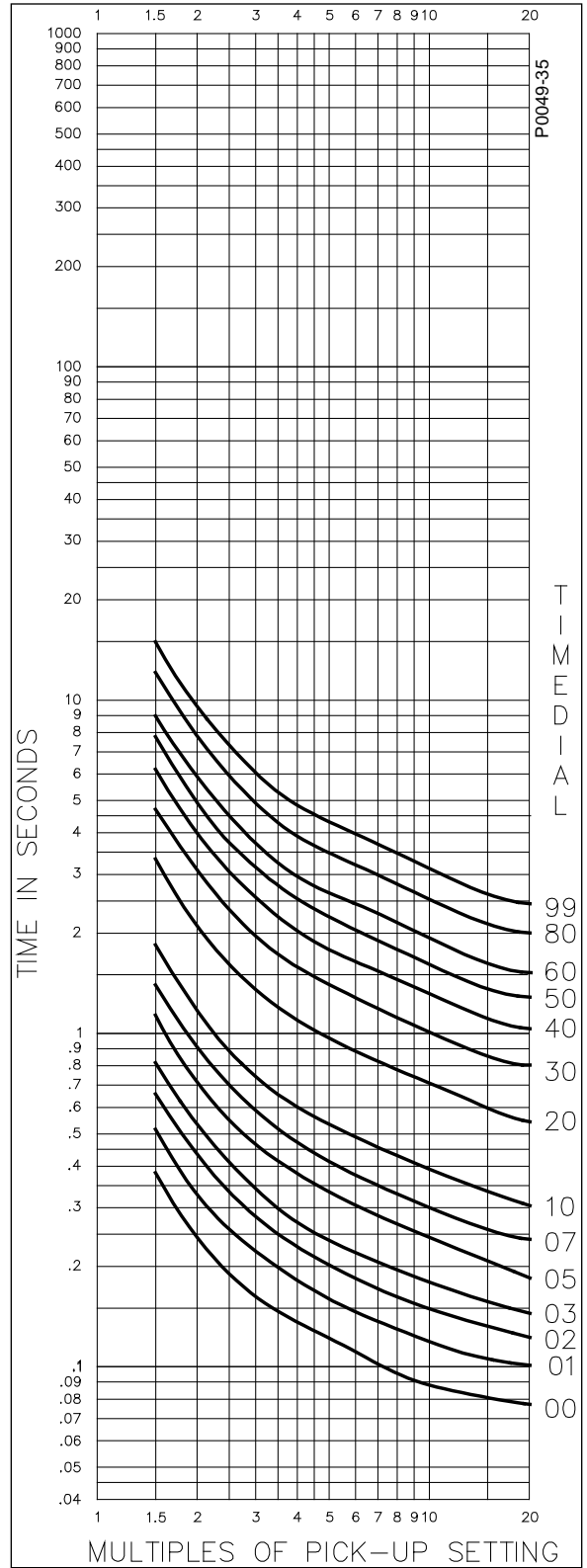

Figure A-34. Timing Type E4,
BS 142 Inverse

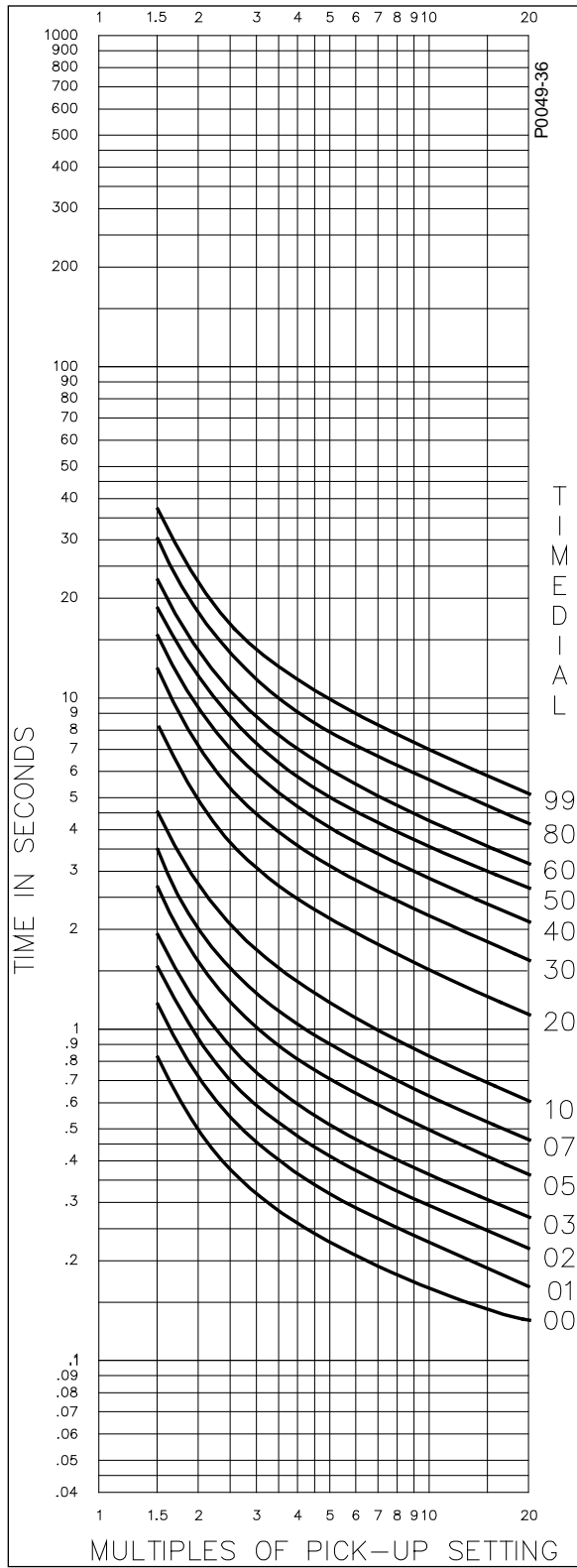

Figure A-35. Timing Type E5,
BS 142 Inverse

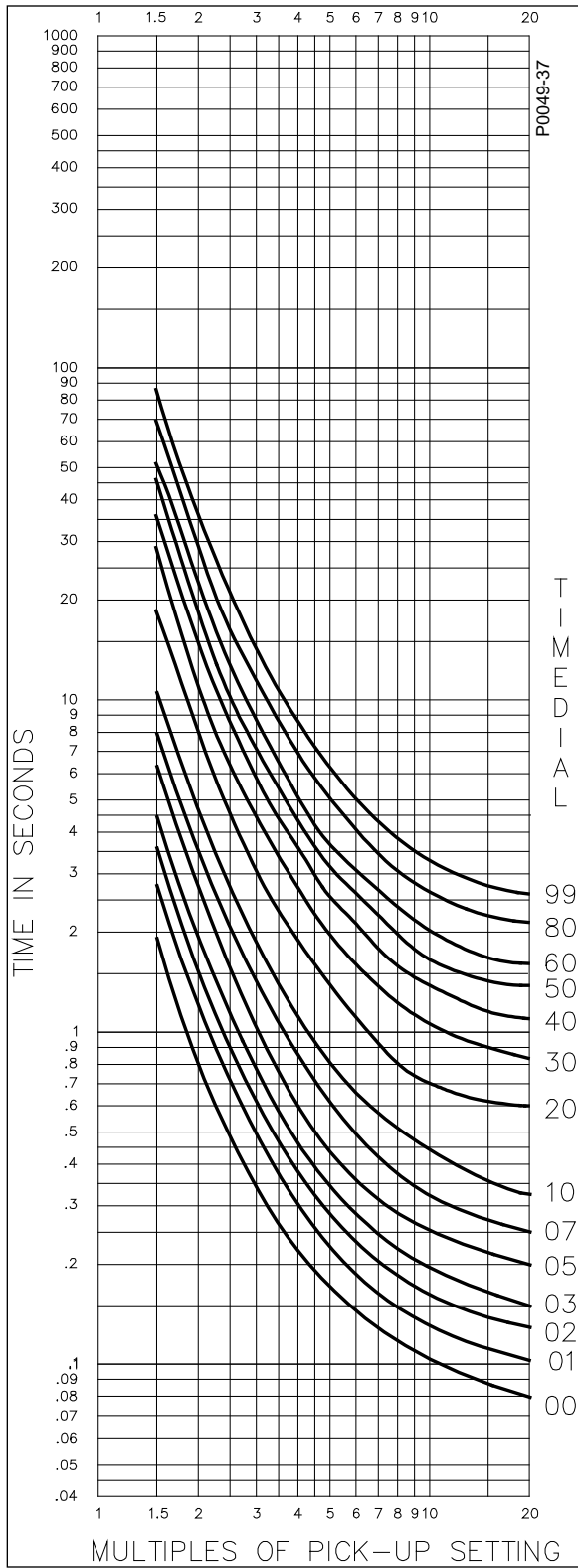

Figure A-36. Timing Type E6,
BS 142 Very Inverse

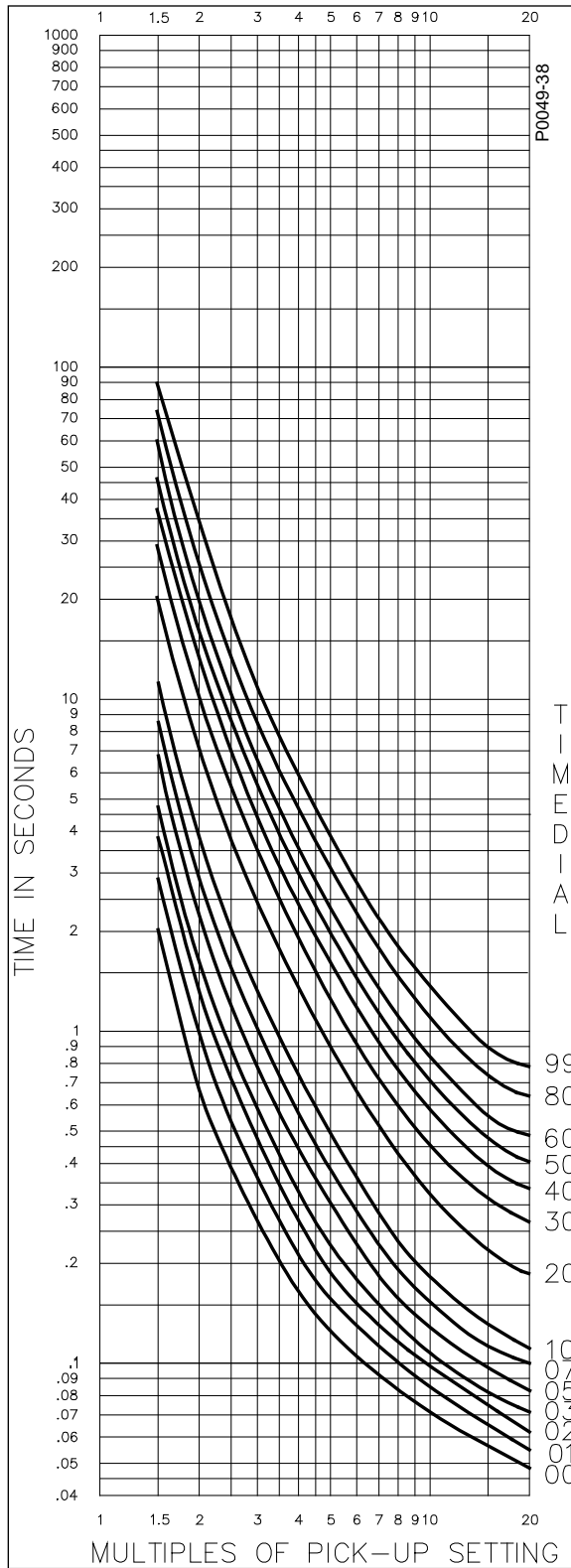

Figure A-37. Timing Type E7,
BS 142 Extremely Inverse

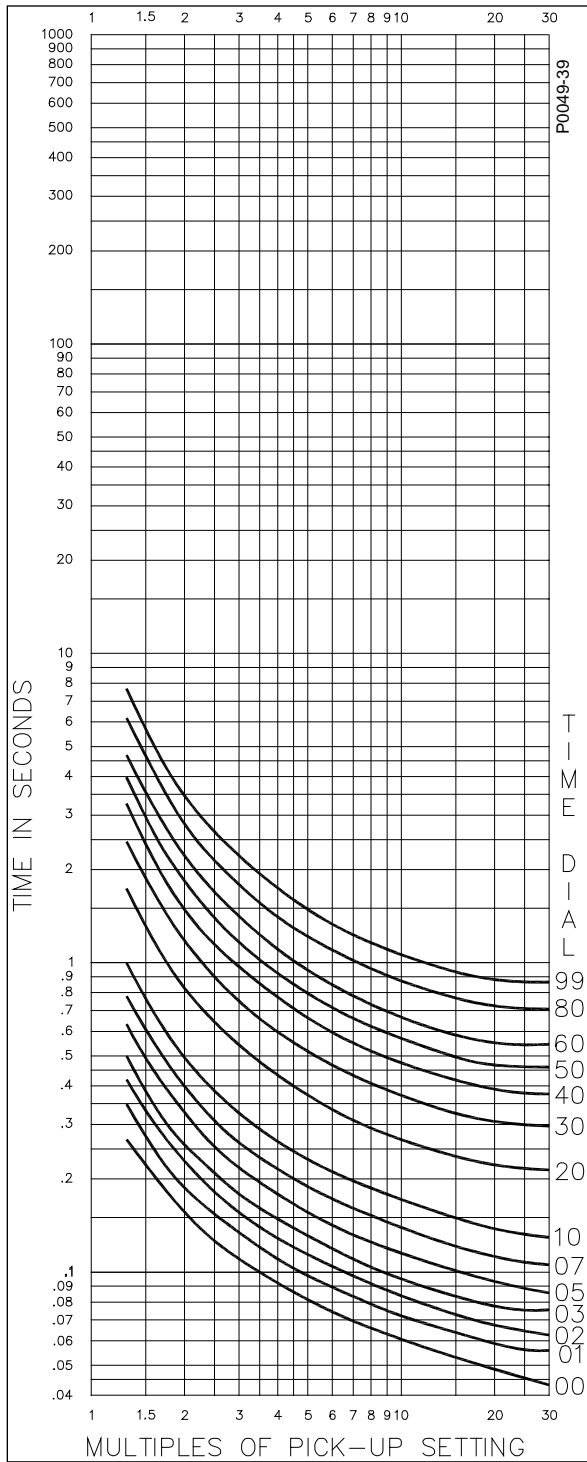

Figure A-38. Timing Type B1, Short Inverse with Integrated Algorithm

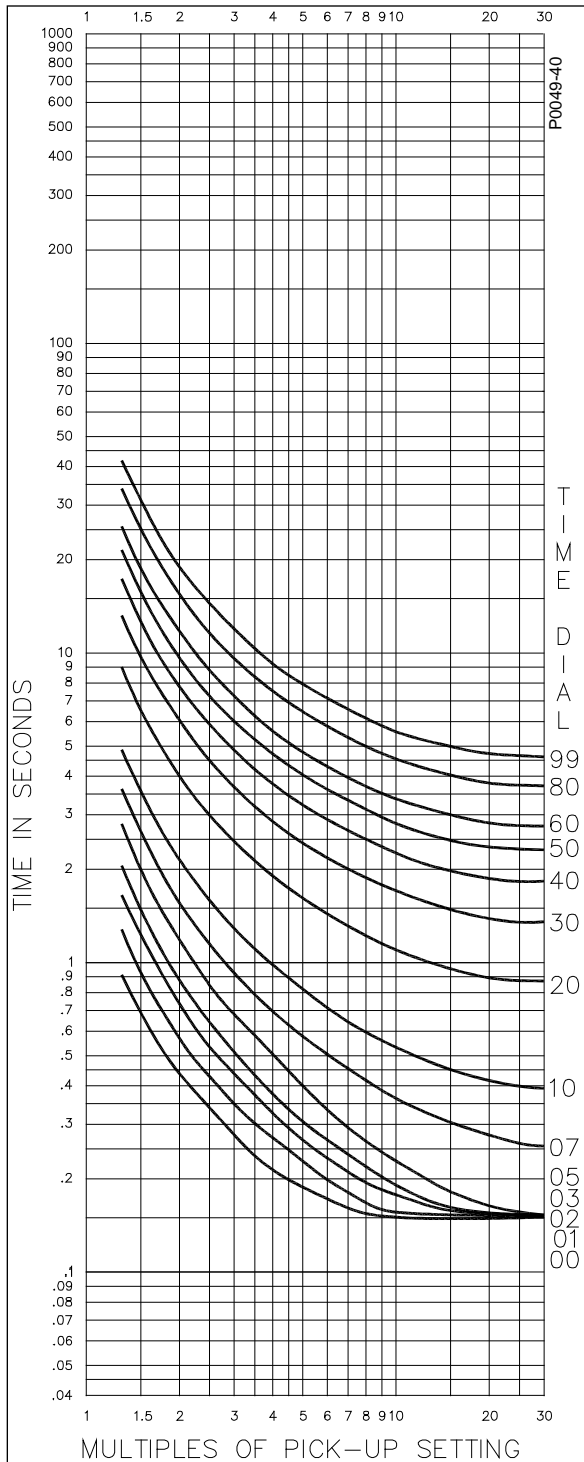

Figure A-39. Timing Type B1, Short Inverse with Integrated Algorithm and Extended Timing

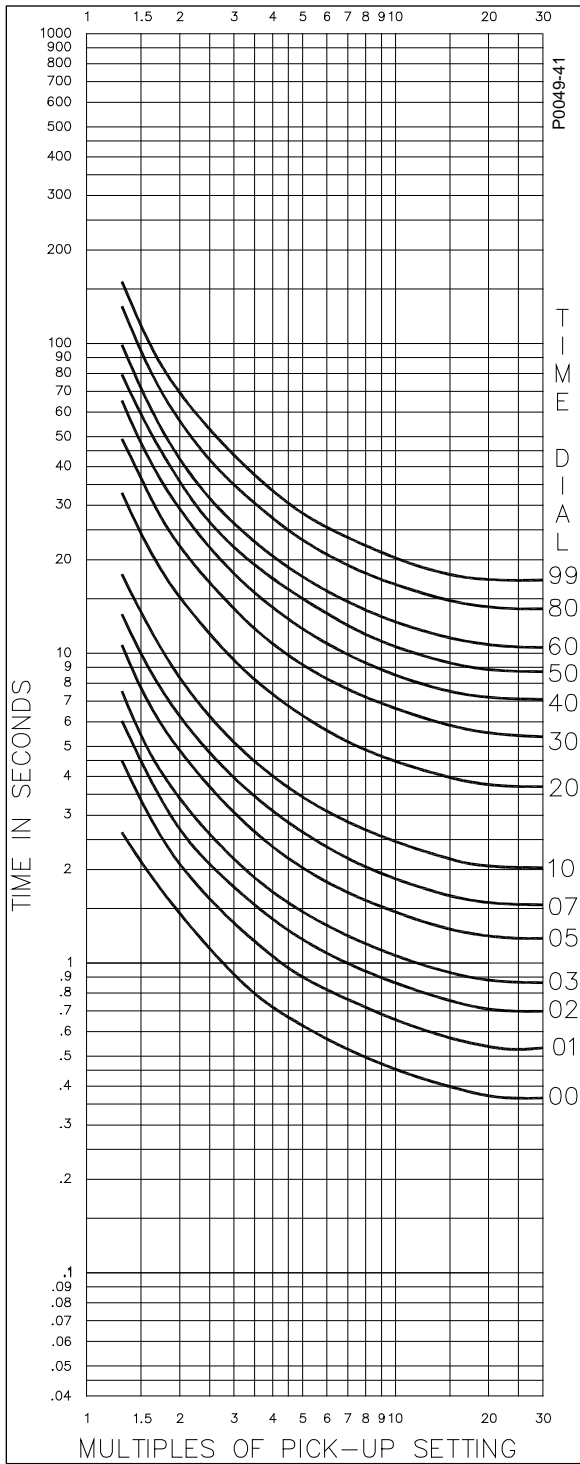

Figure A-40. Timing Type B2, Long Inverse with Integrated Algorithm

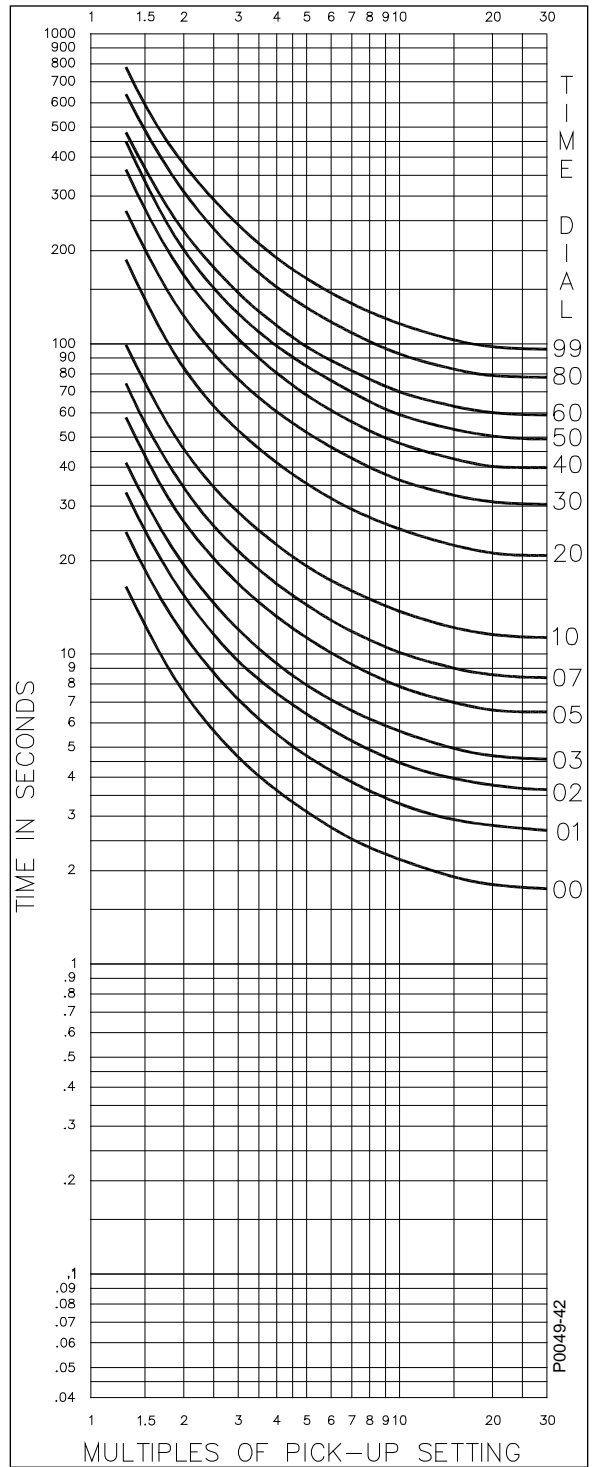

Figure A-41. Timing Type B2, Long Inverse with Integrated Algorithm and Extended Timing

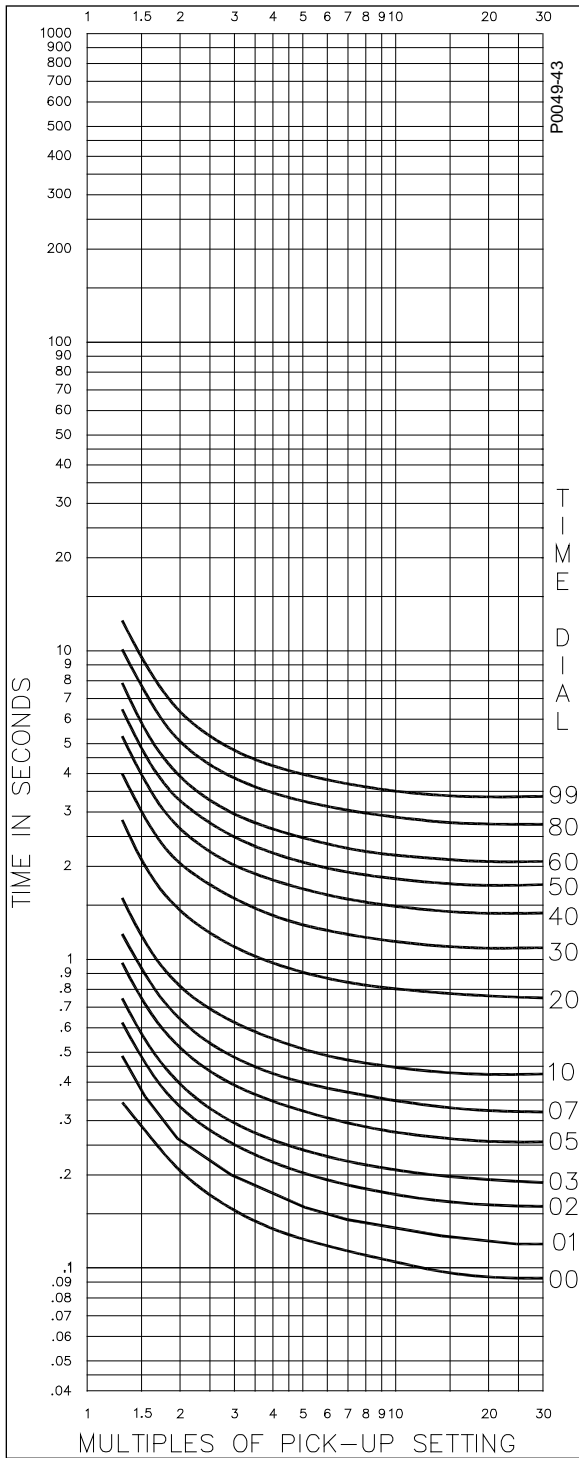

Figure A-42. Timing Type B3, Definite Time with Integrated Algorithm

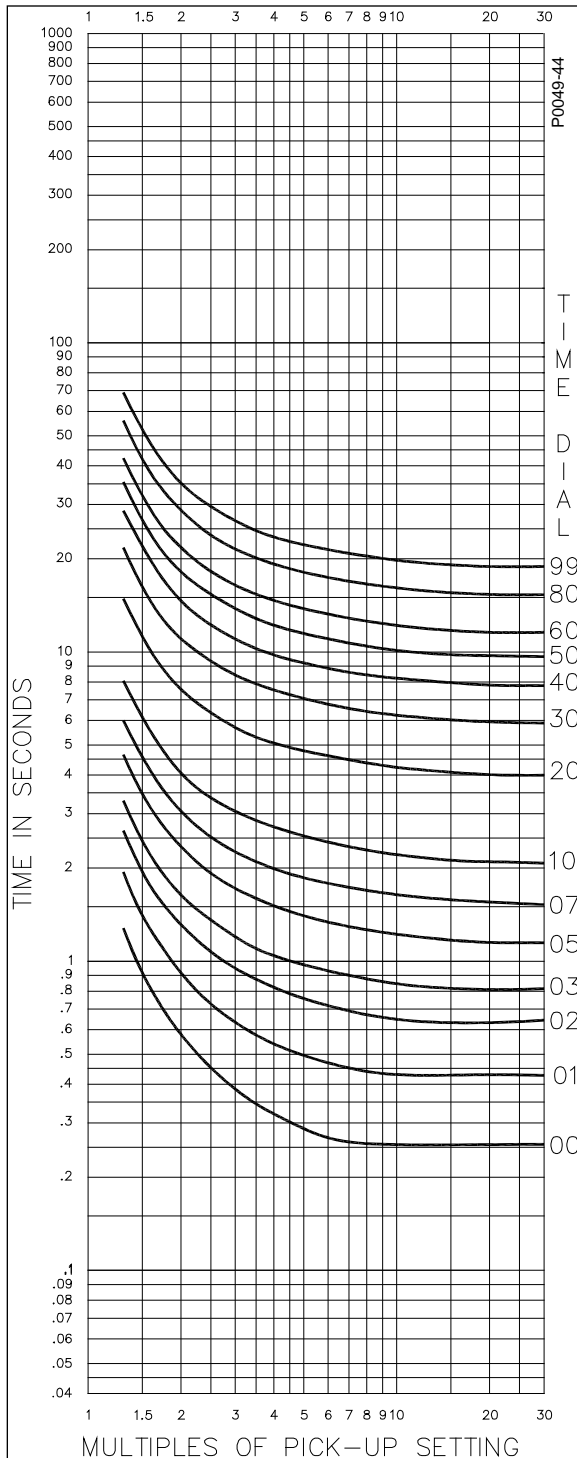

Figure A-43. Timing Type B3, Definite Time with Integrated Algorithm and Extended Timing

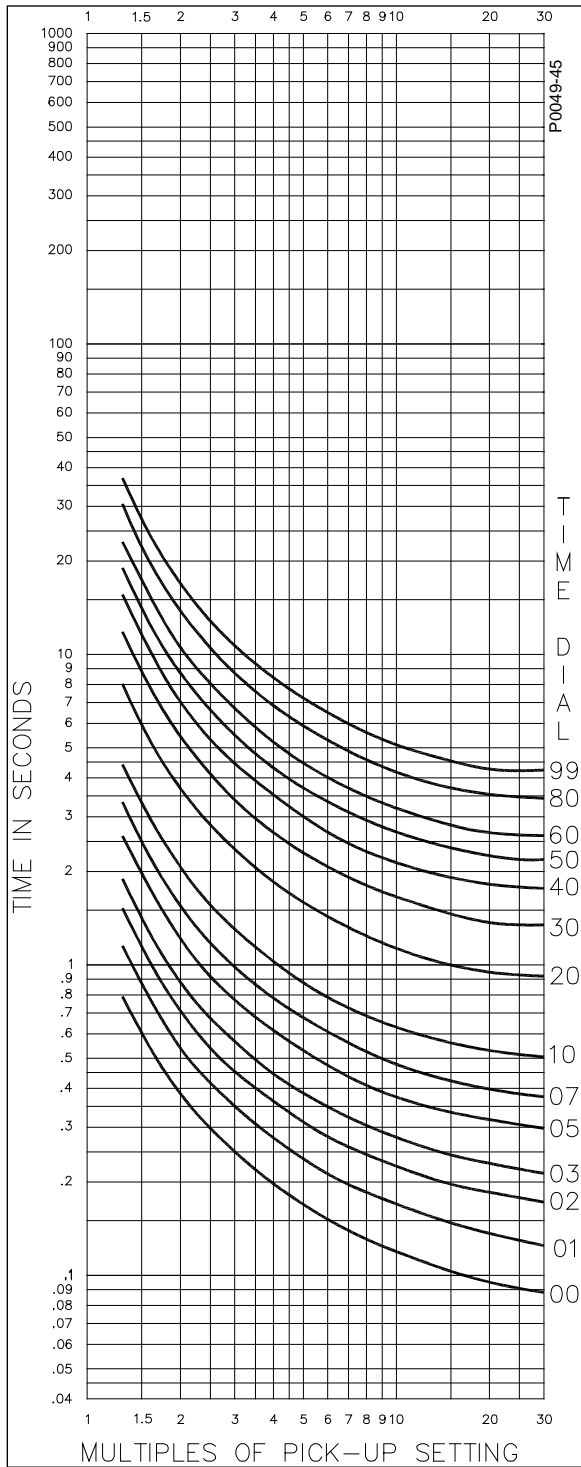

Figure A-44. Timing Type B4, Moderately Inverse with Integrated Algorithm.

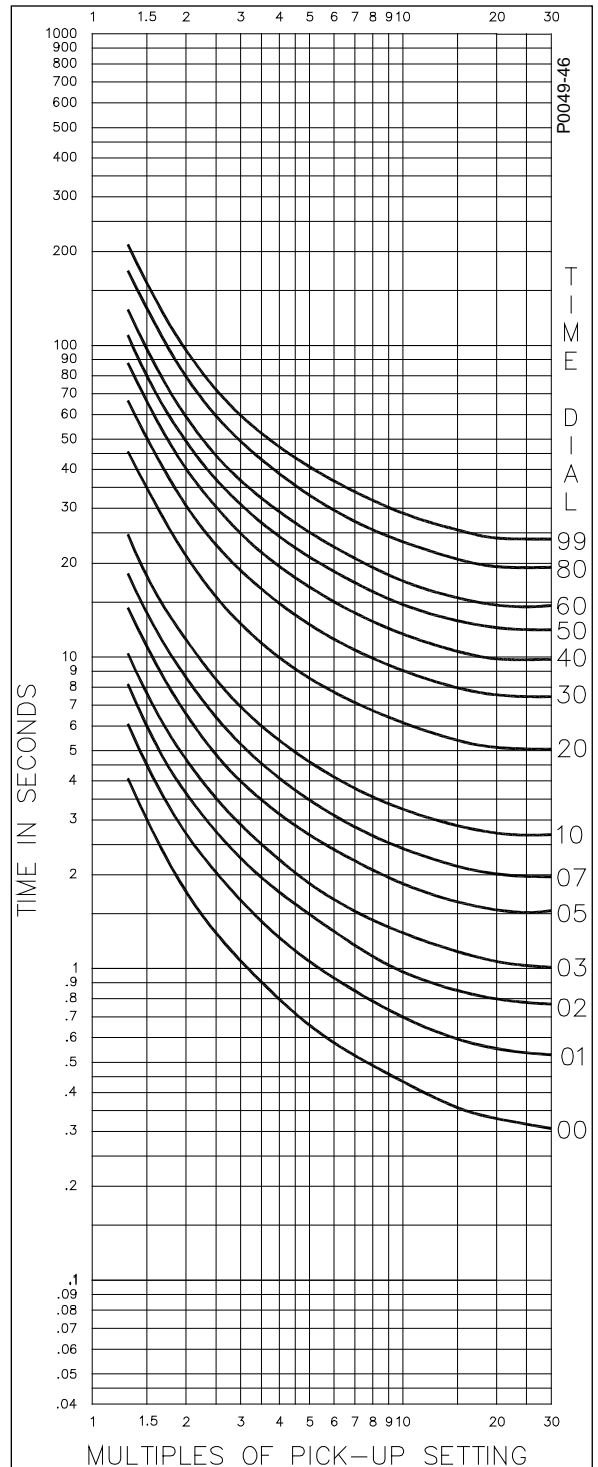

Figure A-45. Timing Type B4, Moderately Inverse with Integrated Algorithm and Extended Timing

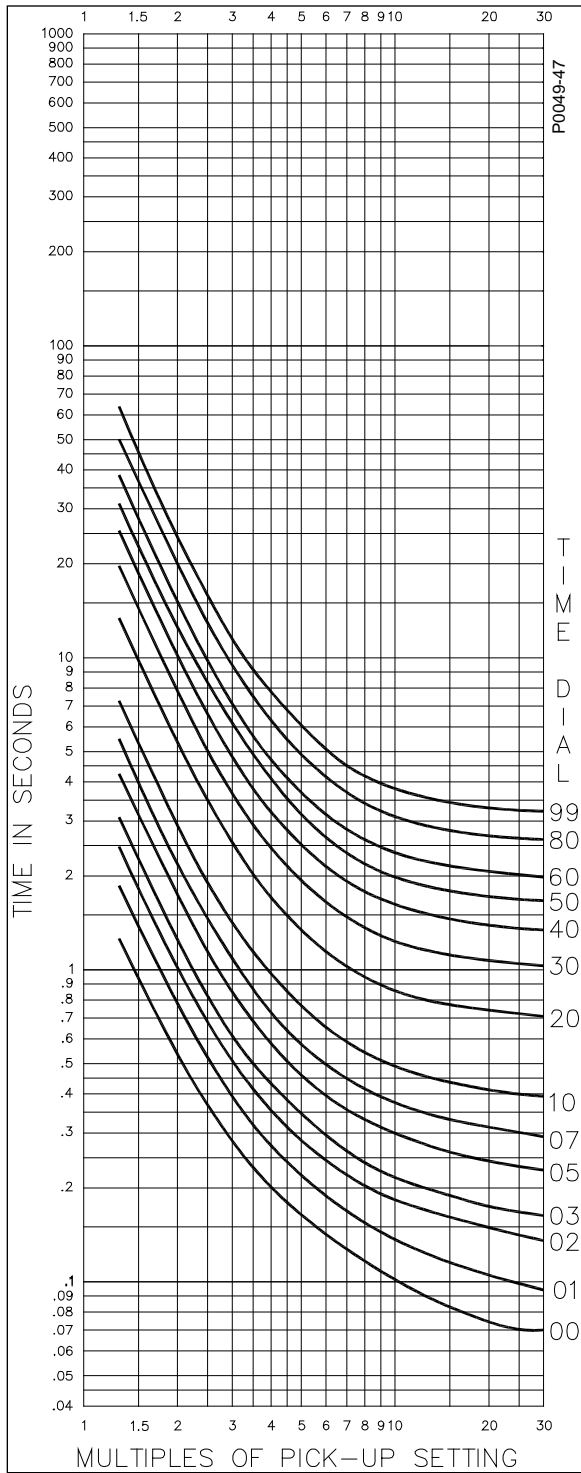

Figure A-46. Timing Type B5, Inverse with Integrated Algorithm

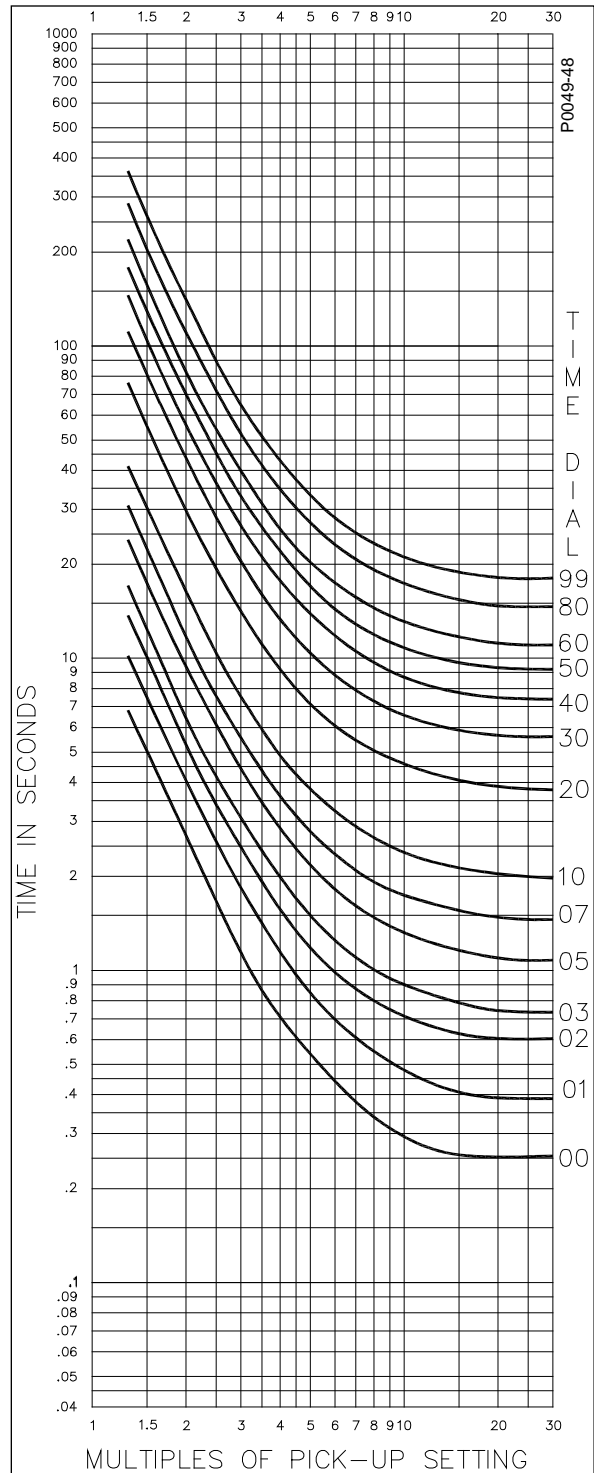

Figure A-47. Timing Type B5, Inverse with Integrated Algorithm and Extended Timing

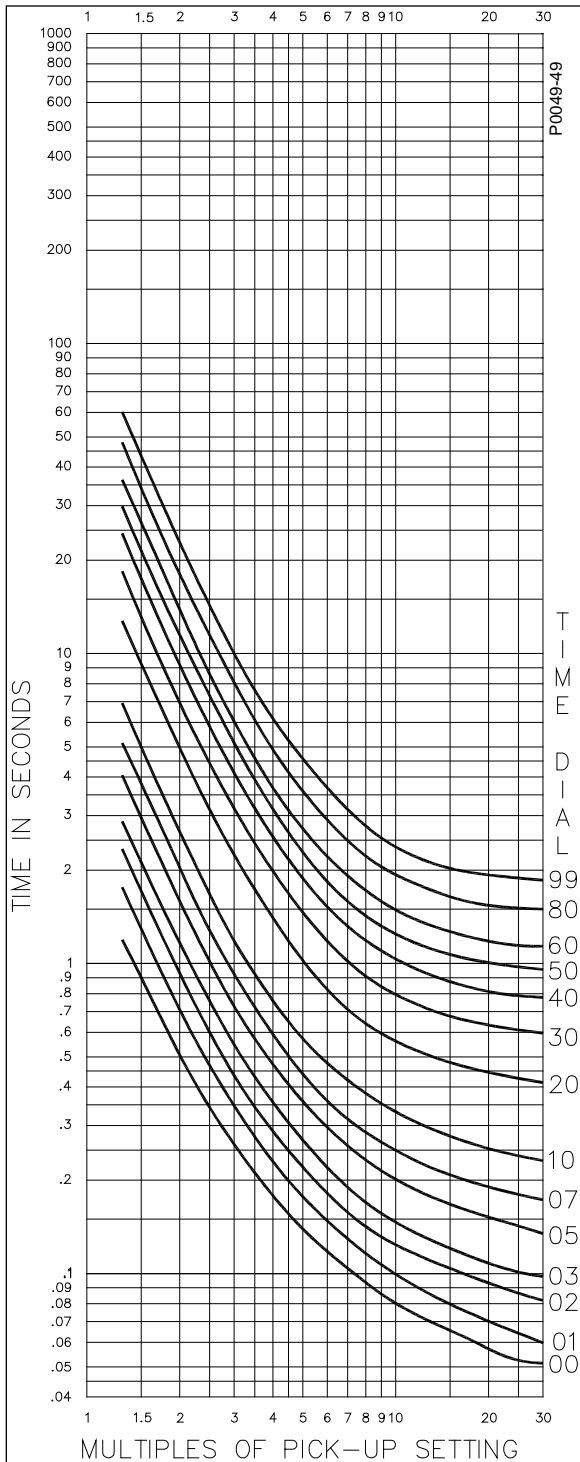

Figure A-48. Timing Type B6, Very Inverse with Integrated Algorithm

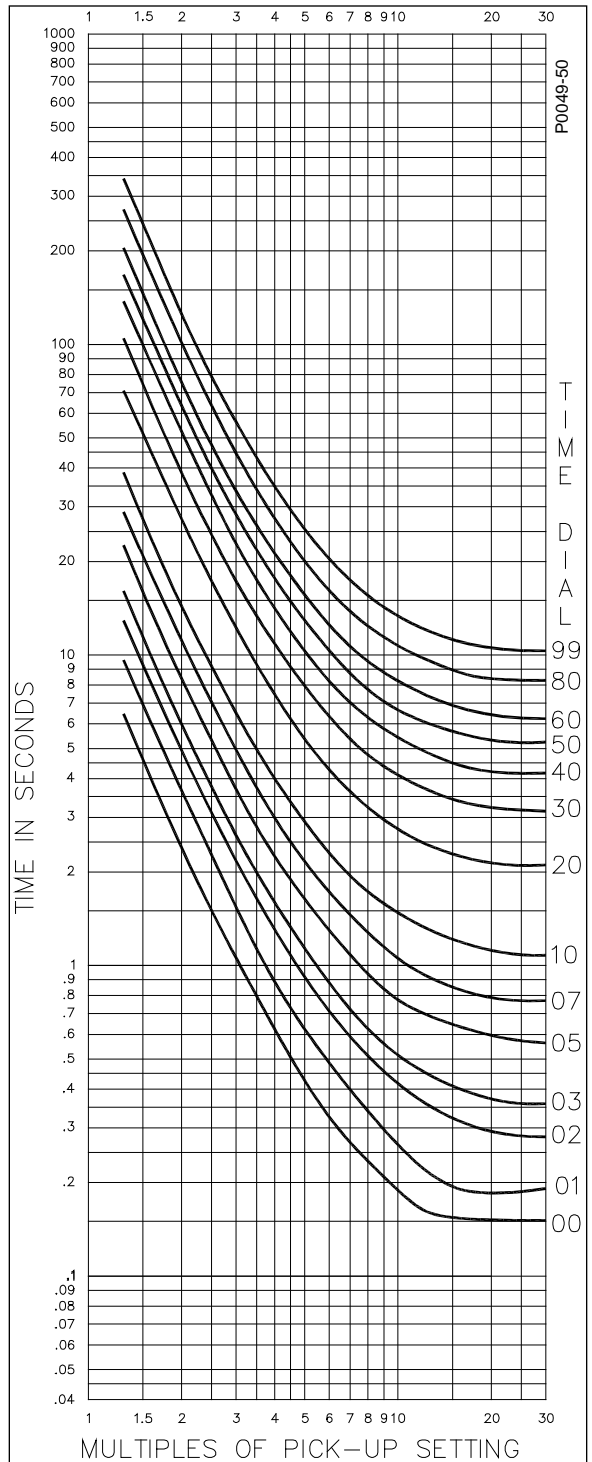

Figure A-49. Timing Type B6, Very Inverse with Integrated Algorithm and Extended Timing

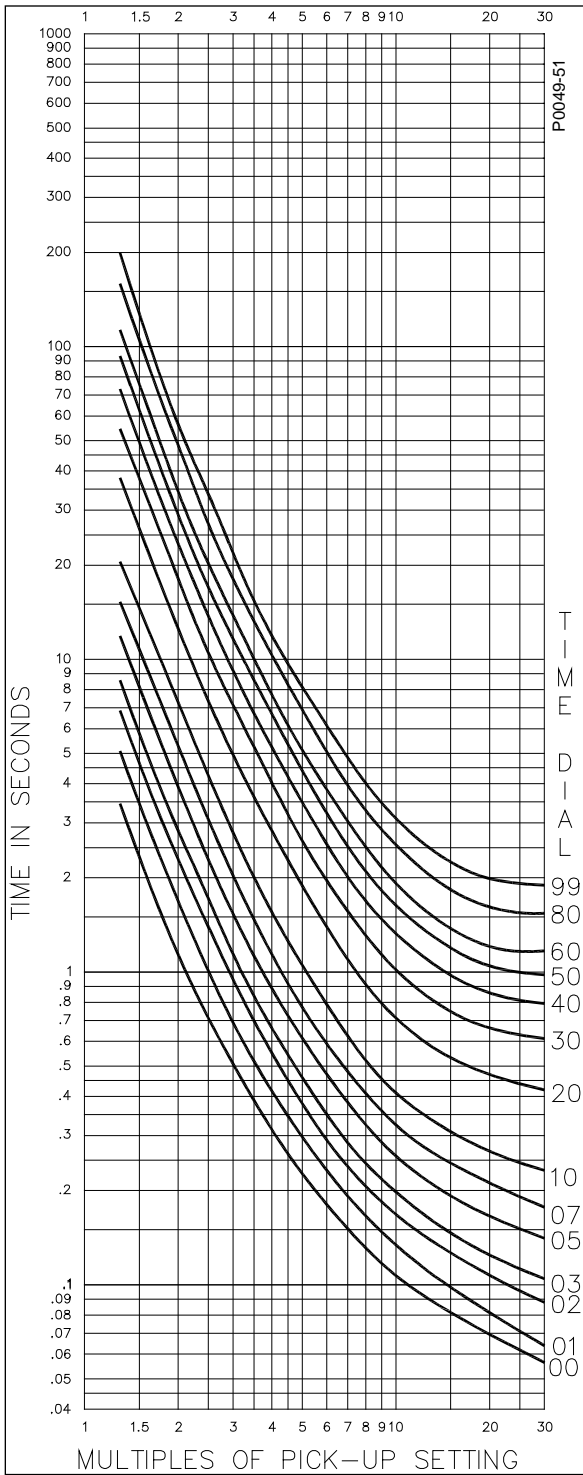

Figure A-50. Timing Type B7, Extremely Inverse with Integrated Algorithm

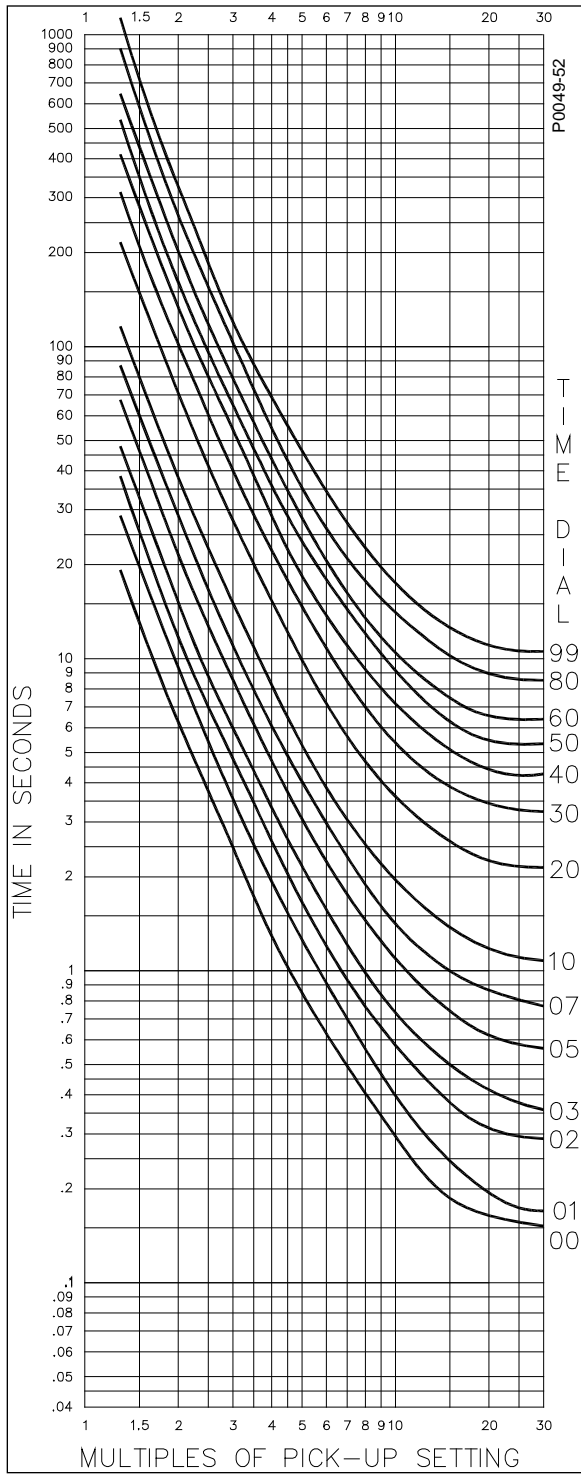

Figure A-51. Timing Type B7, Extremely Inverse with Integrated Algorithm and Extended Timing

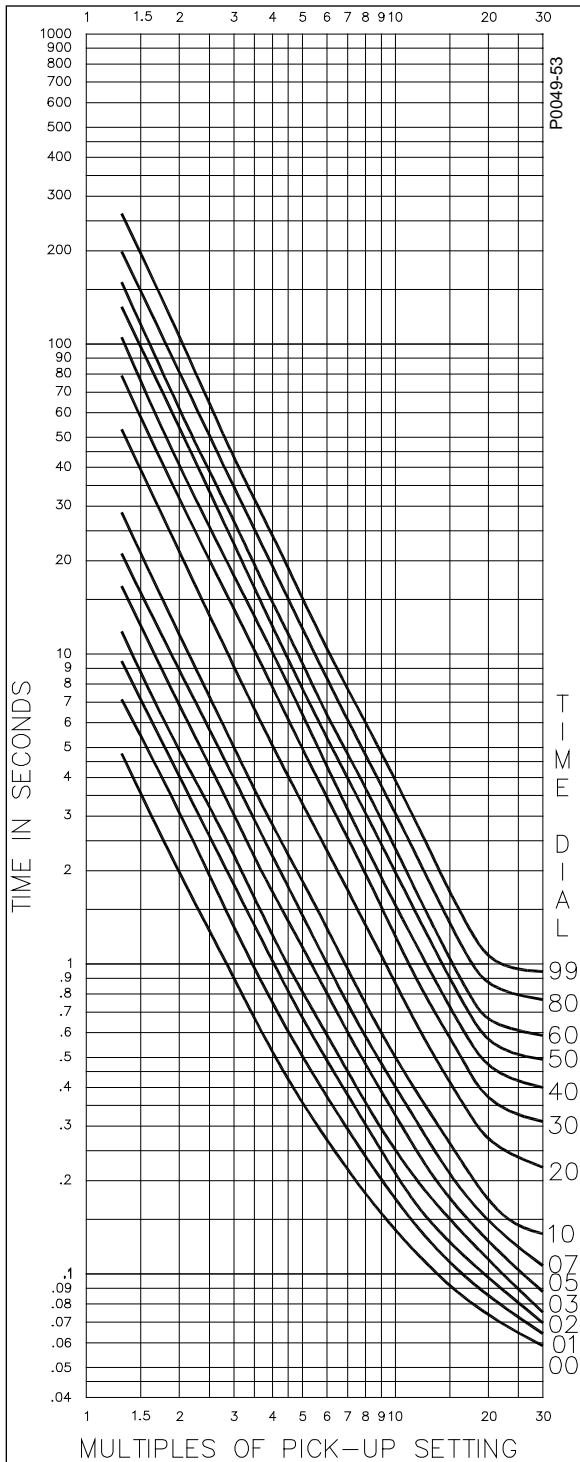

Figure A-52. Timing Type B8, I^2t with Integrated Algorithm

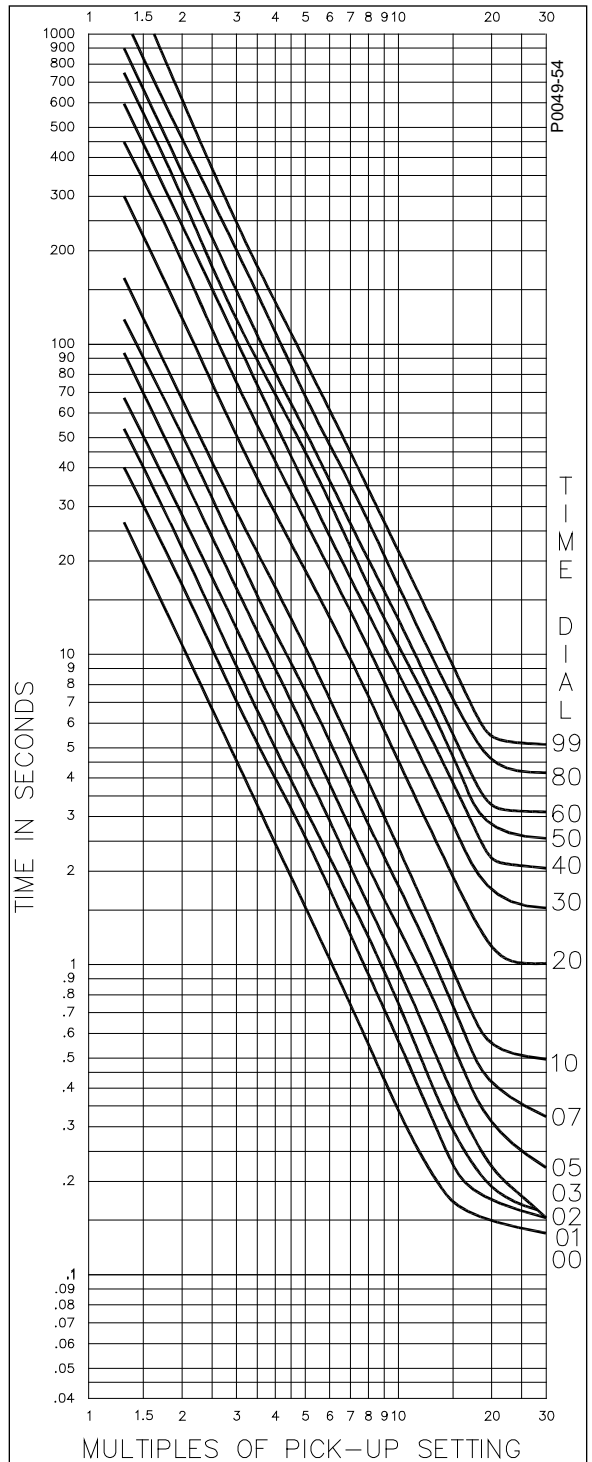

Figure A-53. Timing Type B8, I^2t with Integrated Algorithm and Extended Timing

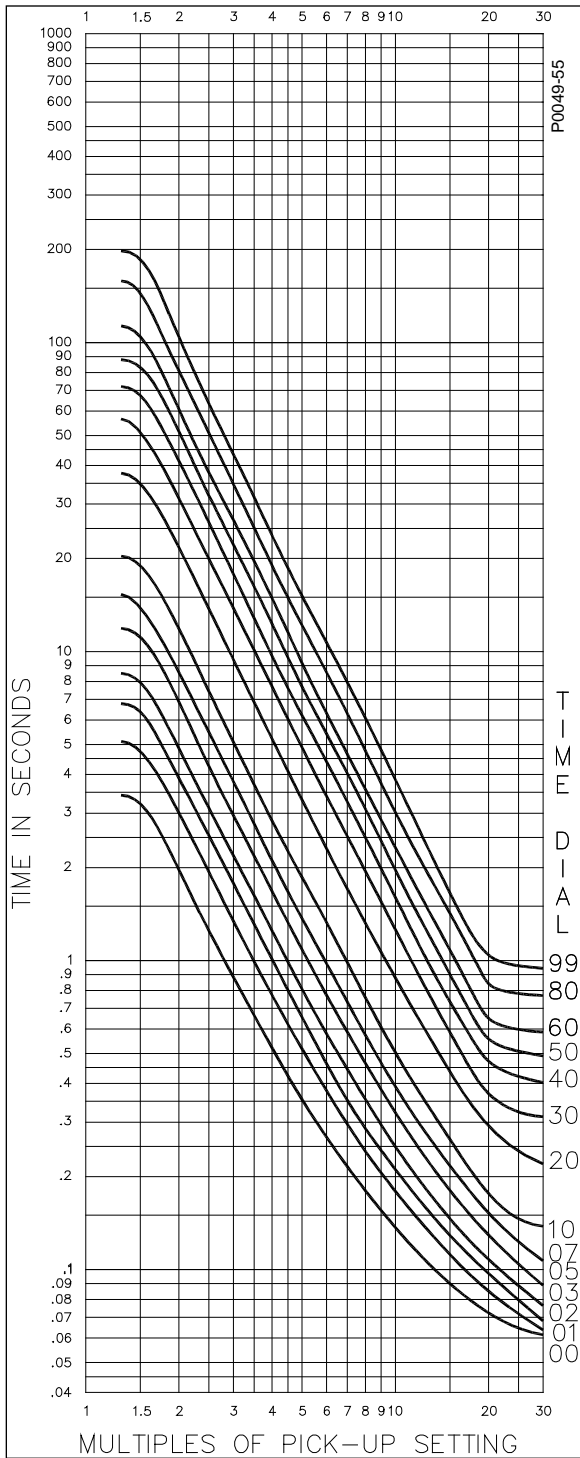

Figure A-54. Timing Type C1, I^2t Limit #1 with Integrated Algorithm

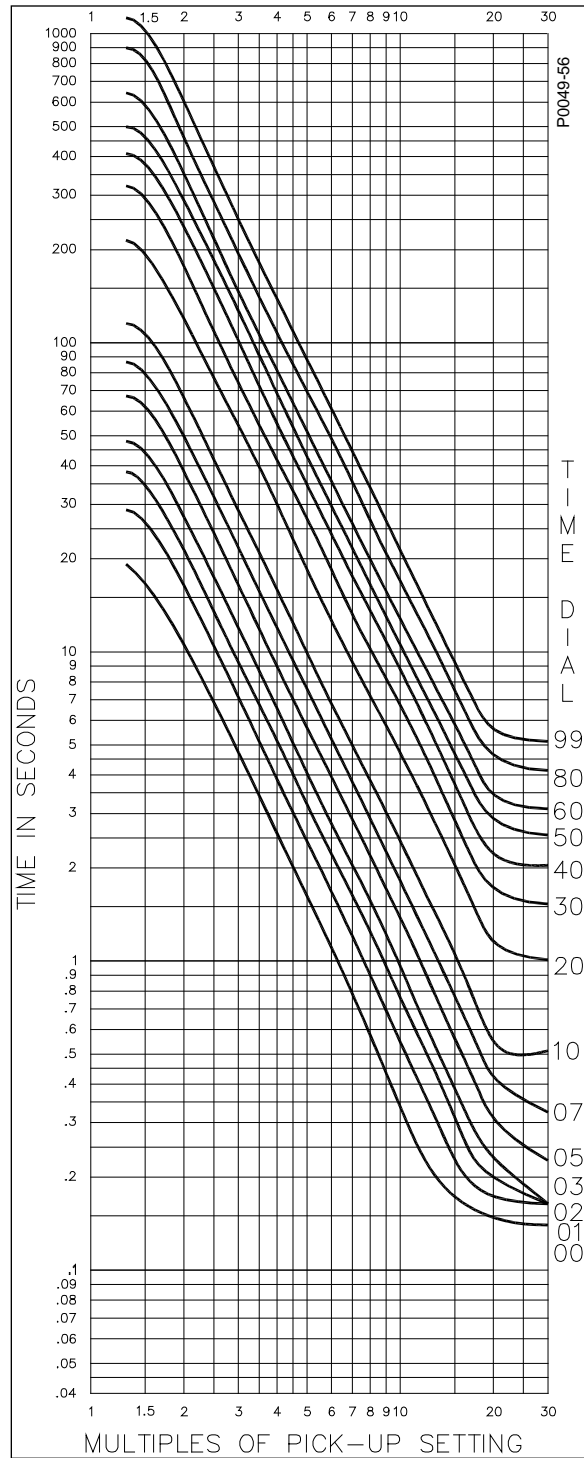

Figure A-55. Timing Type C1, I^2t Limit #1 with Integrated Algorithm

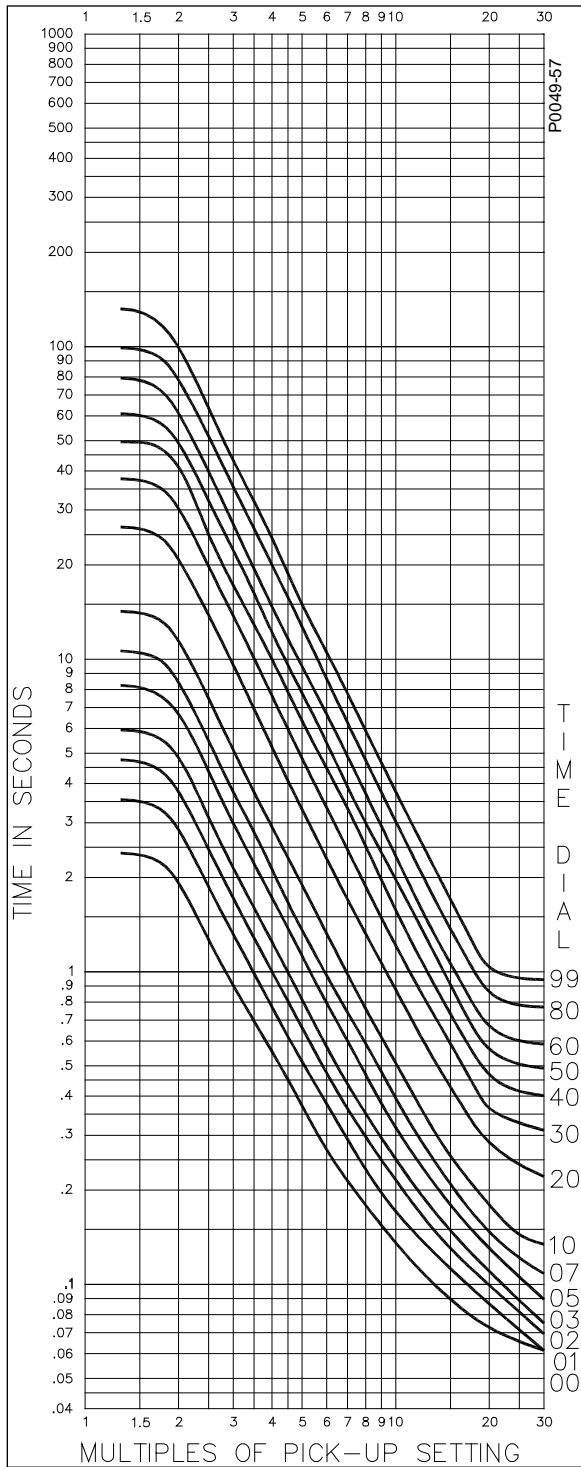

Figure A-56. Timing Type C2, I^2t Limit #2 with Integrated Algorithm

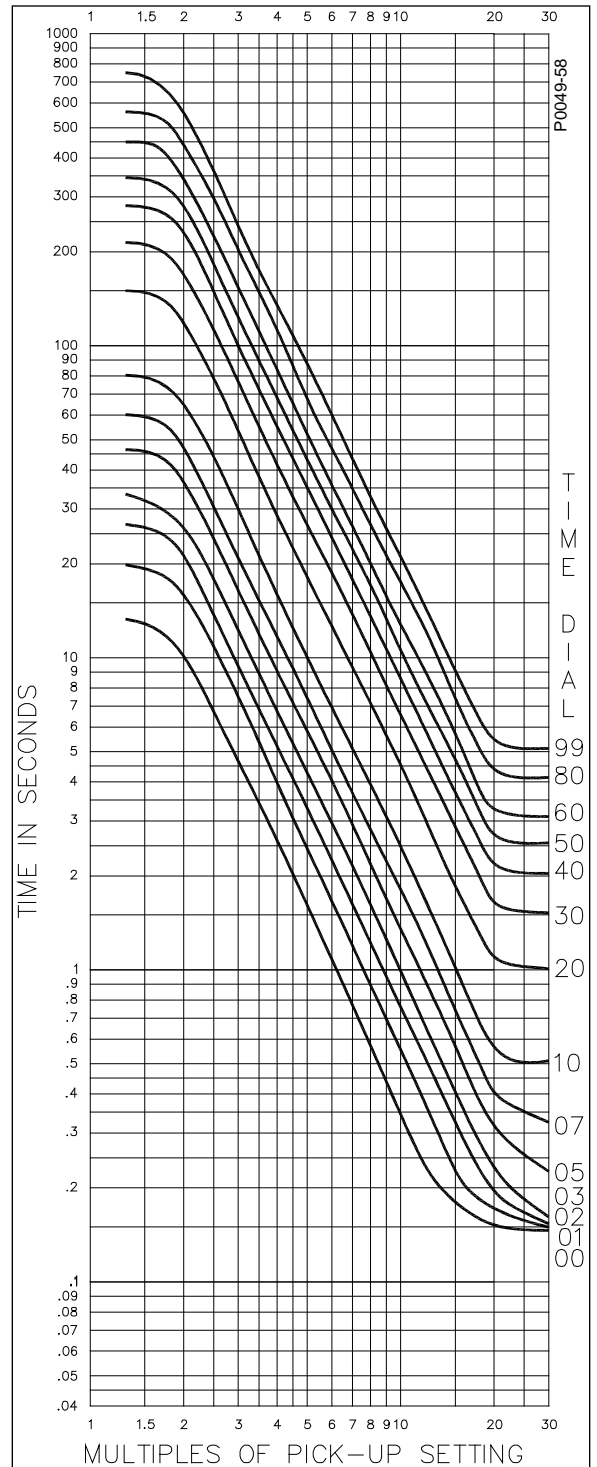

Figure A-57. Timing Type C2, I^2t Limit #2 with Integrated Algorithm and Extended Timing

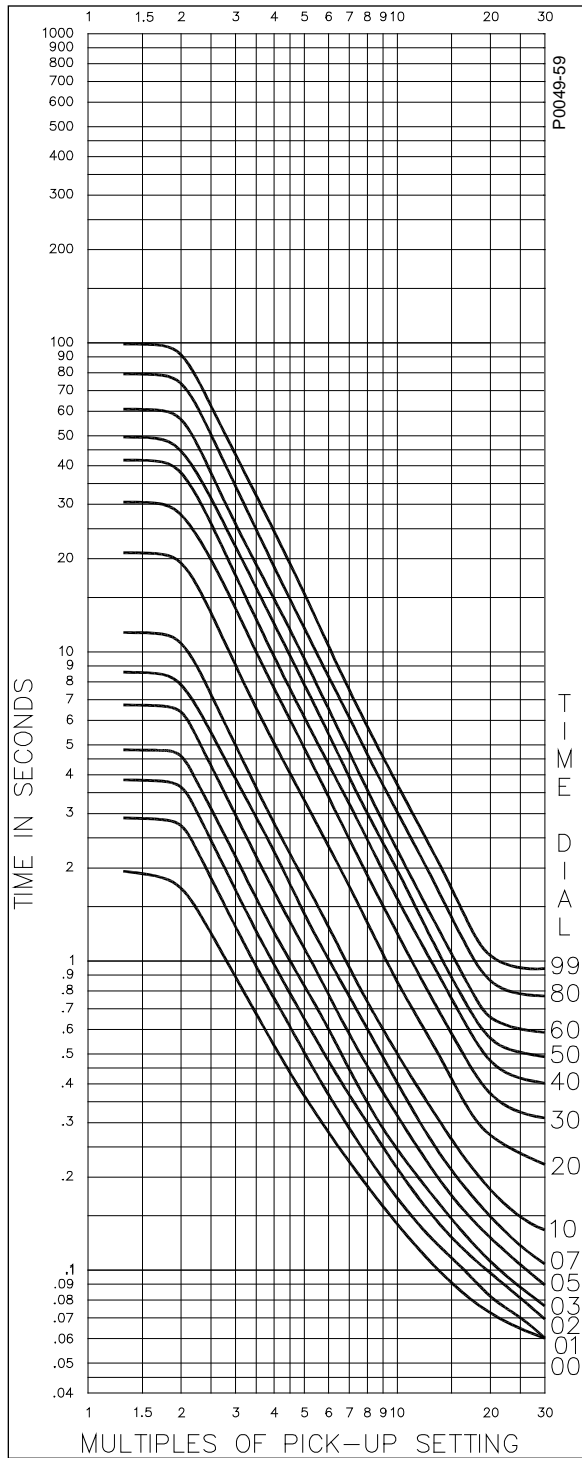

Figure A-58. Timing Type C3, I^2t Limit #3 with Integrated Algorithm

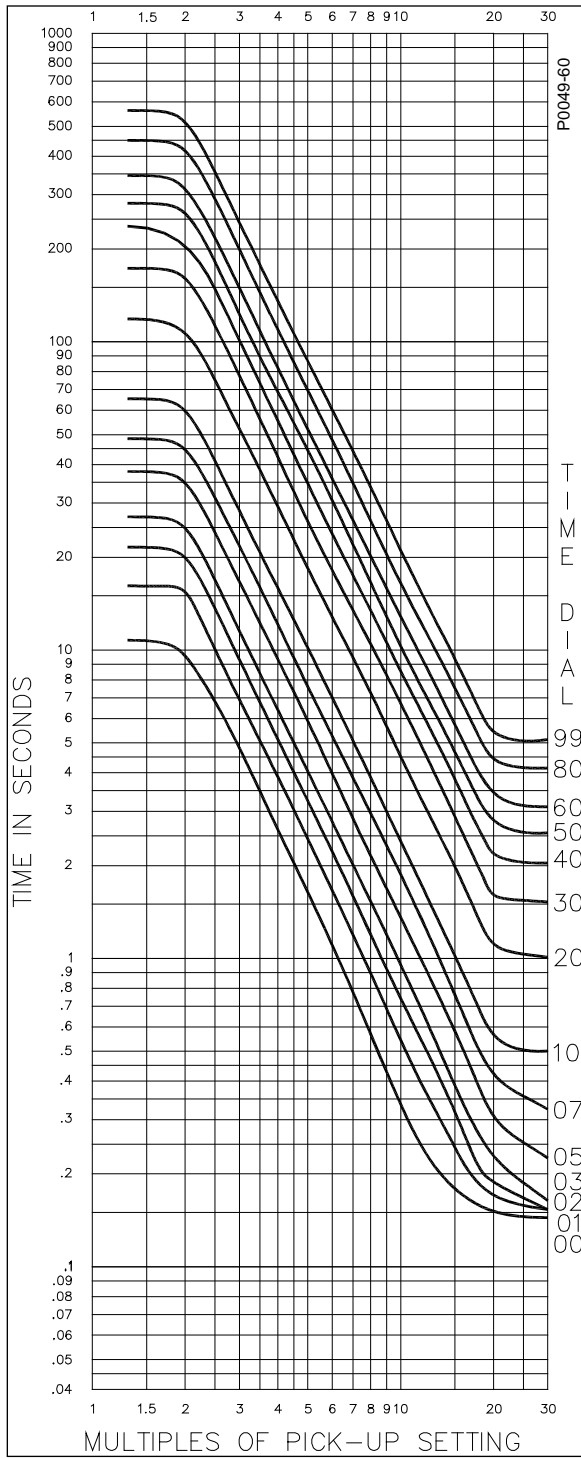

Figure A-59. Timing Type C3, I^2t Limit #3 with Integrated Algorithm and Extended Timing

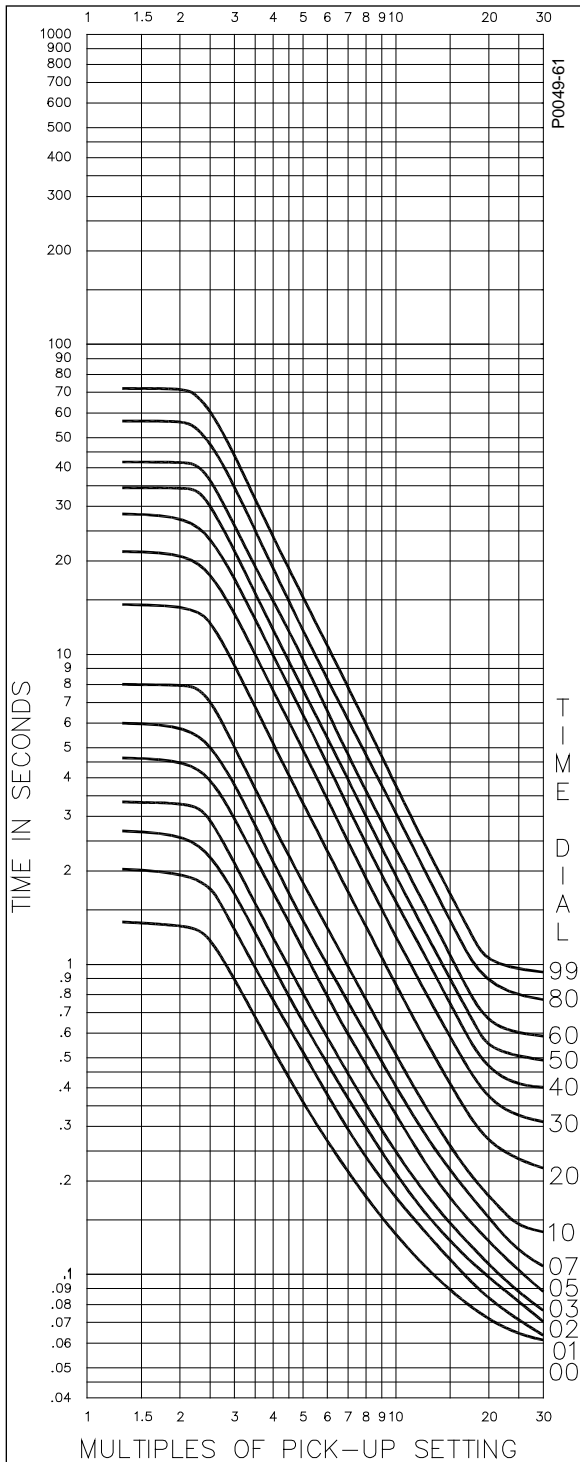

Figure A-60. Timing Type C4, I^2t Limit #4 with Integrated Algorithm

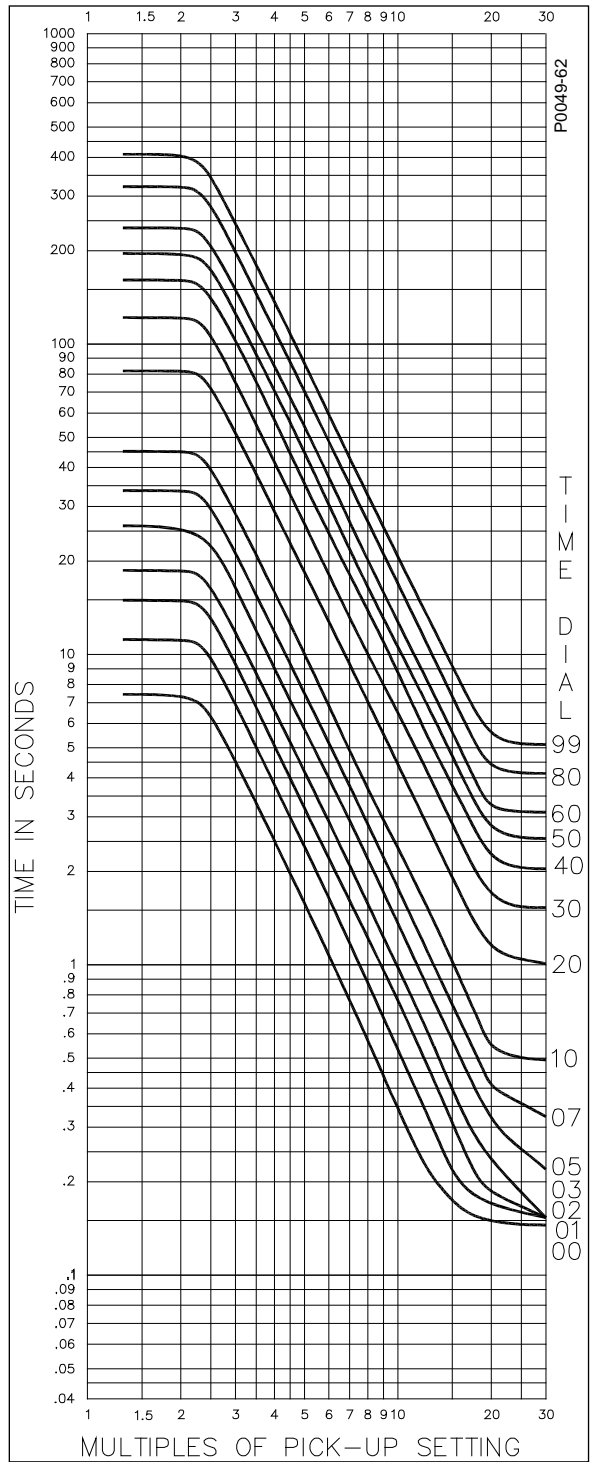

Figure A-61. Timing Type C4, I^2t Limit #4 with Integrated Algorithm and Extended Timing

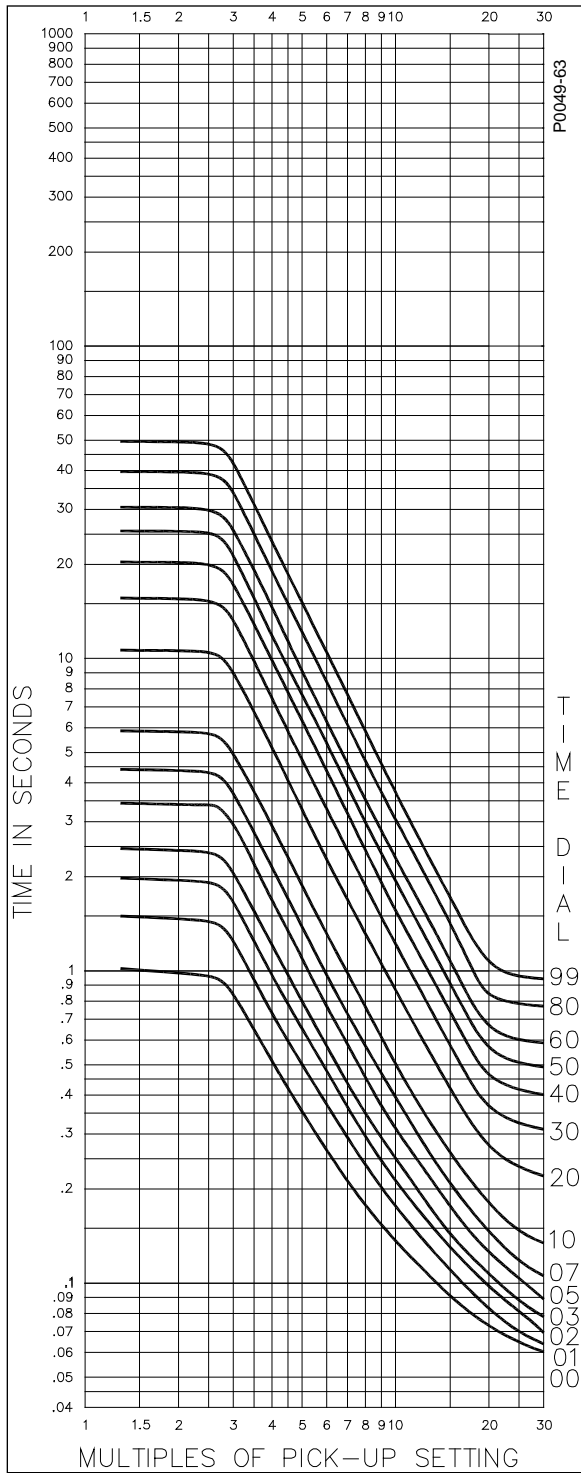

Figure A-62. Timing Type C5, I^2t Limit #5 with Integrated Algorithm

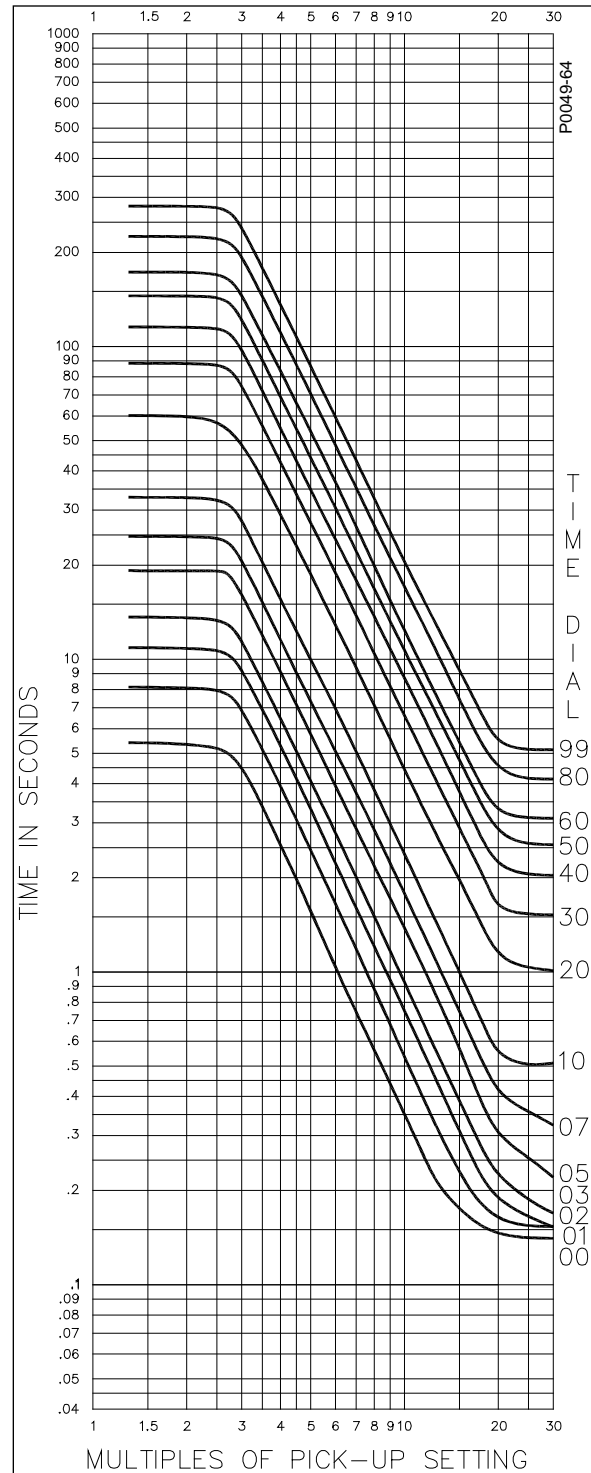

Figure A-63. Timing Type C5, I^2t Limit #5 with Integrated Algorithm and Extended Timing

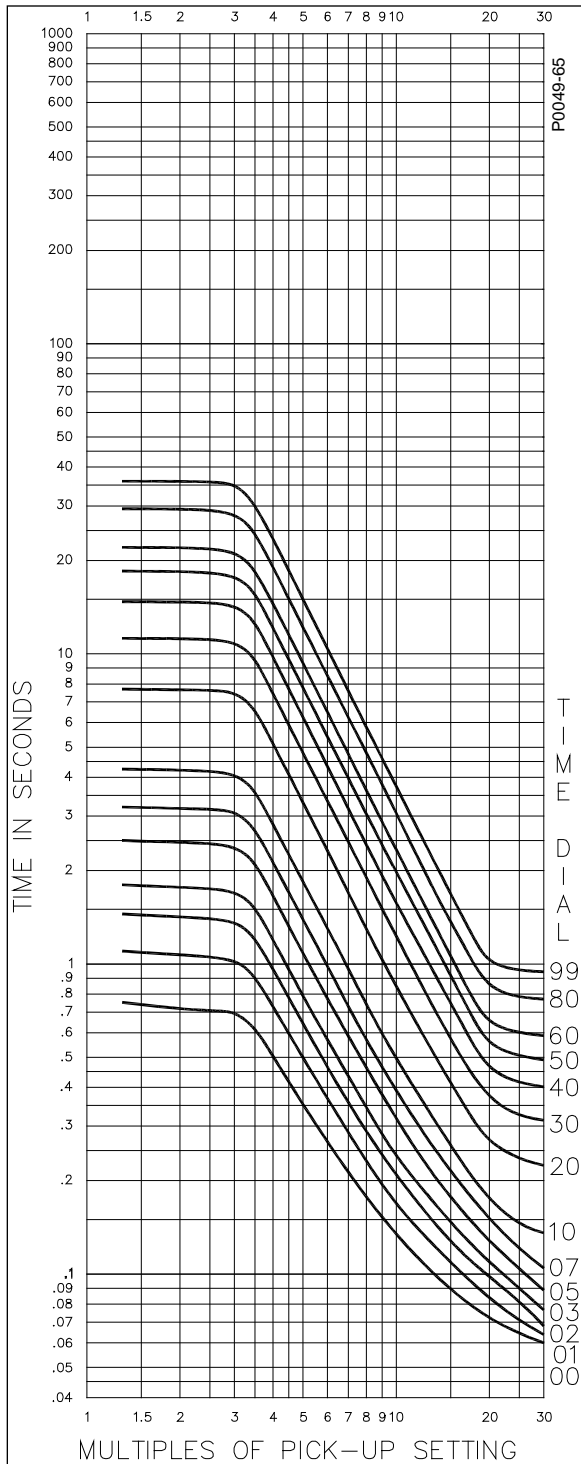

Figure A-64. Timing Type C6, f_t Limit #6 with Integrated Algorithm

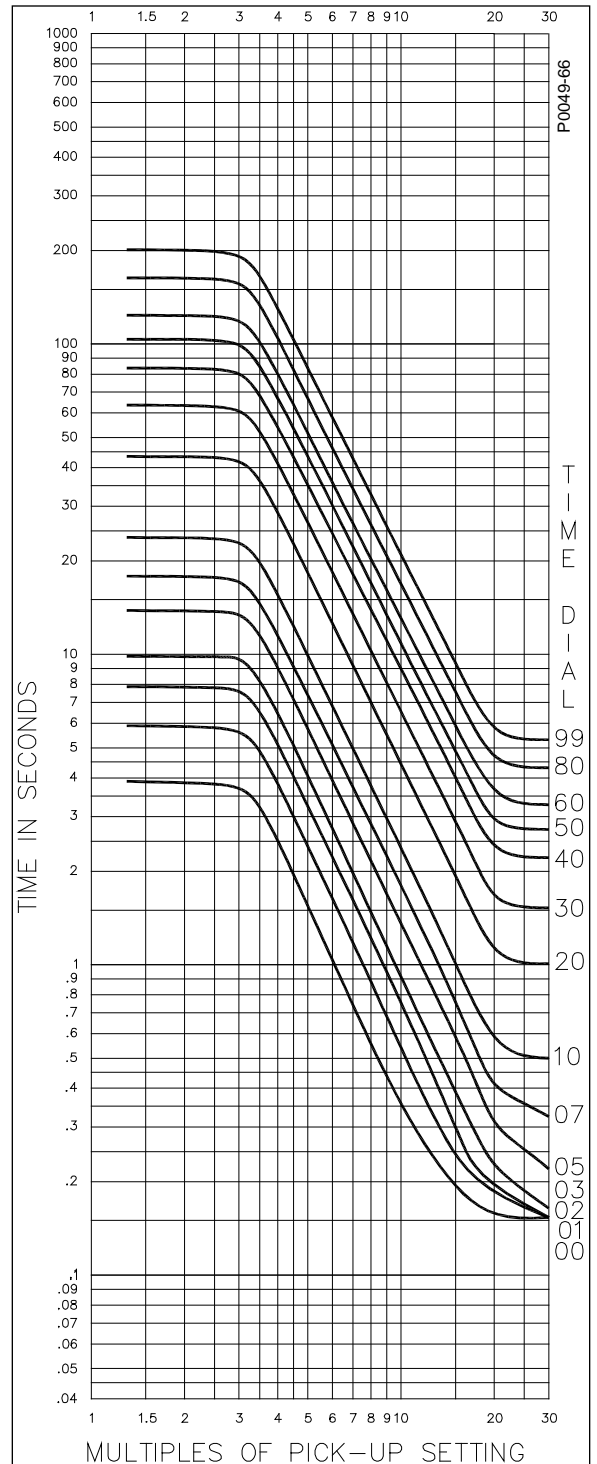

Figure A-65. Timing Type C6, f_t Limit #6 with Integrated Algorithm and Extended Timing

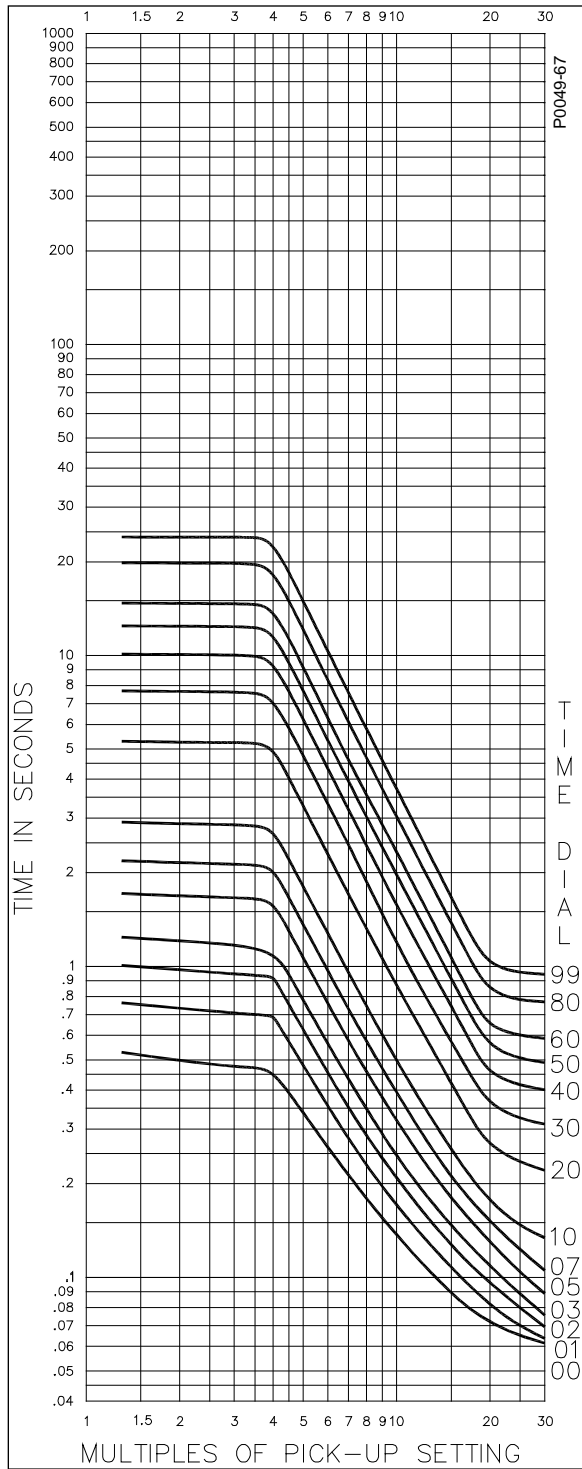

Figure A-66. Timing Type C7, I_t Limit #7 with Integrated Algorithm

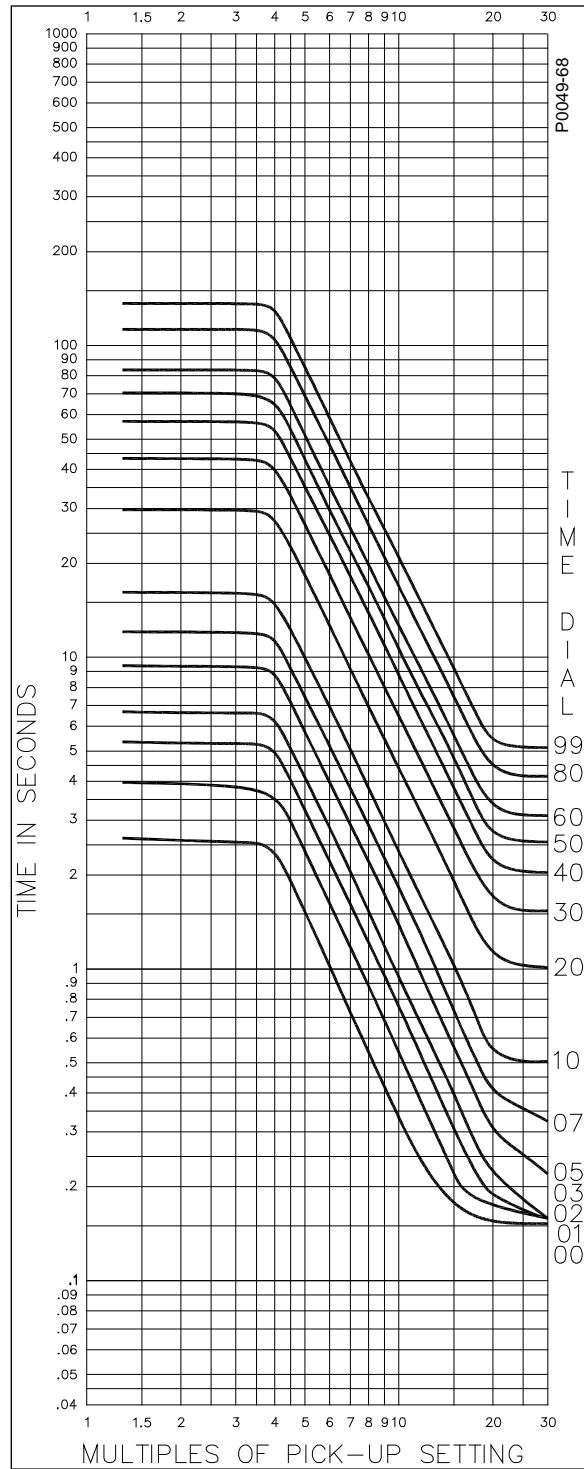

Figure A-67. Timing Type C7, I_t Limit #7 with Integrated Algorithm and Extended Timing

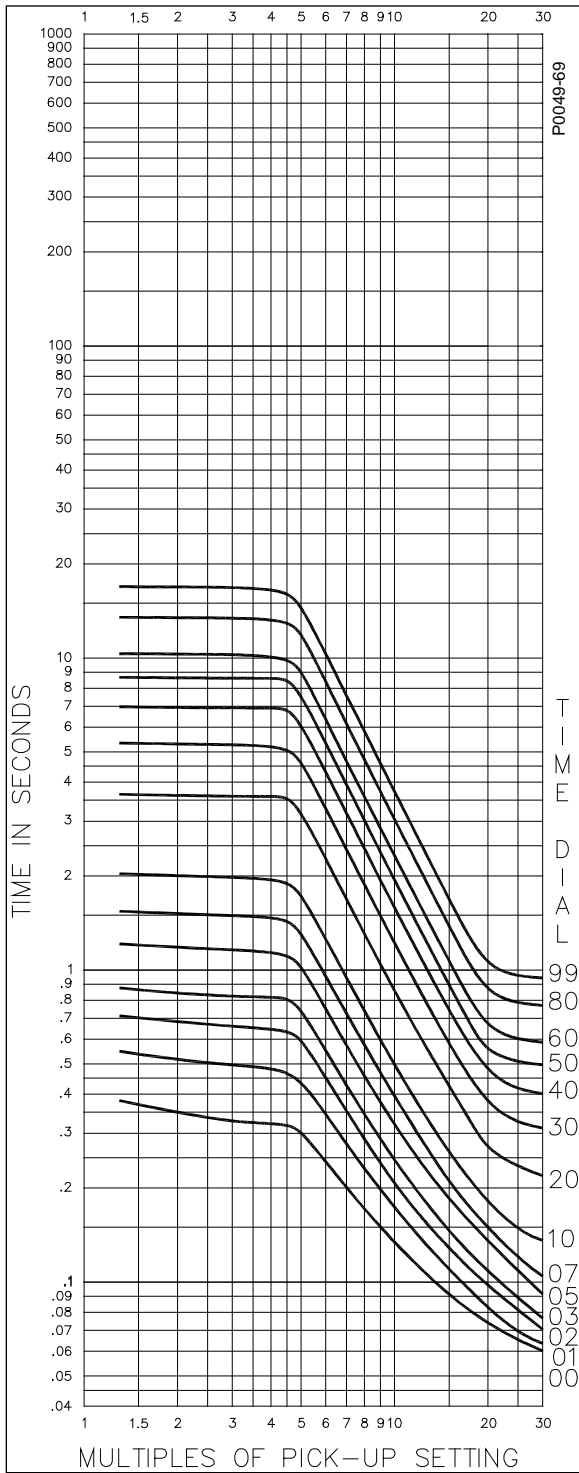

Figure A-68. Timing Type C8, I^2t Limit #8 with Integrated Algorithm

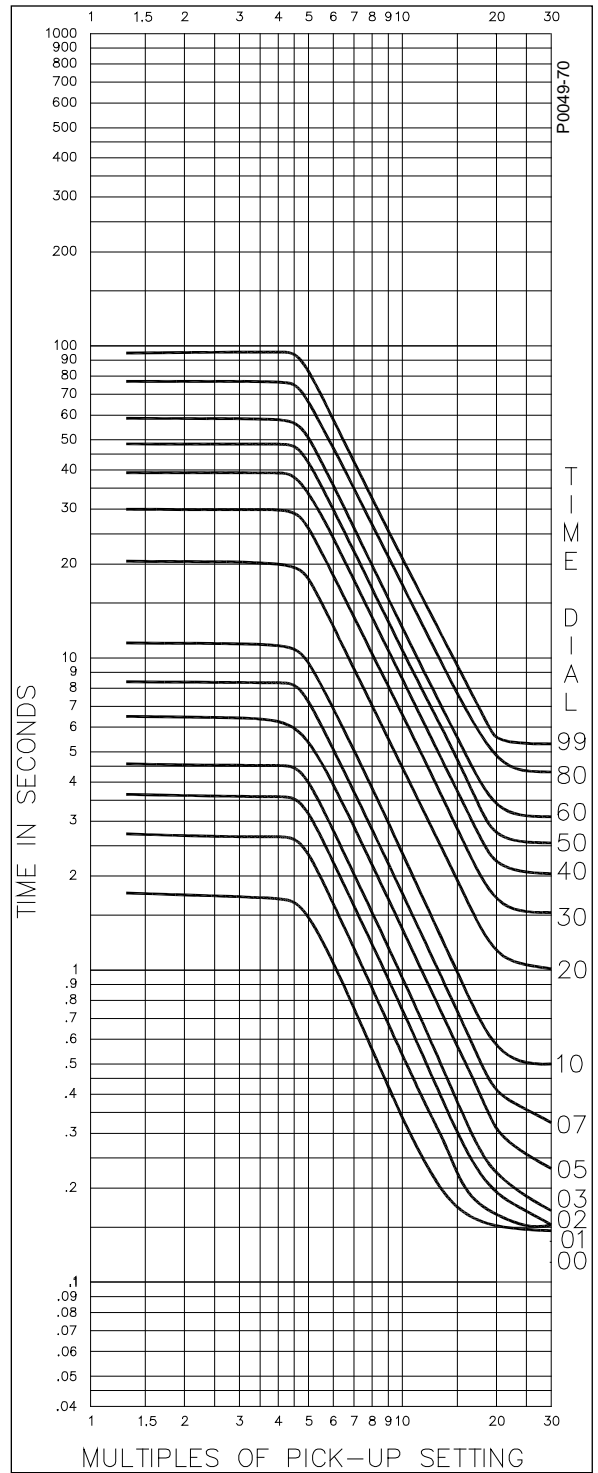

Figure A-69. Timing Type C8, I^2t Limit #8 with Integrated Algorithm and Extended Timing

This page intentionally left blank.

 **Basler Electric**
ROUTE 143, BOX 269
HIGHLAND, IL 62249 USA
<http://www.basler.com>, info@basler.com

PHONE +1 618-654-2341

FAX +1 618-654-2351