



BLACK BRUIN HYDRAULIC ROTATORS

SUPERIOR PISTON TECHNOLOGY

**Black
Bruin**
No power like it.



ABOUT OUR ROTATORS

Black Bruin harvester rotators are commonly seen in job sites where others just don't get the job done. Many demanding applications in forestry are powered by Black Bruin. With Black Bruin rotators, these professionals know that they will get their job done in productive and profitable manner.

RELIABILITY INCORPORATED

Black Bruin rotator design is based on the radial piston motor, thus giving the same highly efficient power seen in the motors. The power does not run out and a harvester head

can be precisely turned to wanted position.

OVER 50 YEARS OF EXPERIENCE

For over 50 years, our aim has been high quality in all areas. From design to manufacturing, we strive to meet our customers' high demands and give them powerful, reliable and high quality hydraulic rotators. Customer satisfaction and consistent quality of Black Bruin rotators are further ensured by our own R&D testing laboratory, in which we continuously work to develop even better solutions for all

conditions and needs.

We listen to the customer and develop innovative rotator solutions to fit their needs.

CONTENTS

INTRODUCTION 3 | PISTON TECHNOLOGY 5 | HARVESTER ROTATORS 7 | LINKS 9 | BRAKES 11 | HYDRAULICALLY CONTROLLED SWING DAMPER 13 | ORDERING CODE 15



All information given in this brochure is current and valid according to the information available at the time of publication. Sampo Hydraulics Ltd. reserves the rights to implement changes without prior notice. Please visit www.blackbruin.com for technical specifications and the most recent version of this brochure.

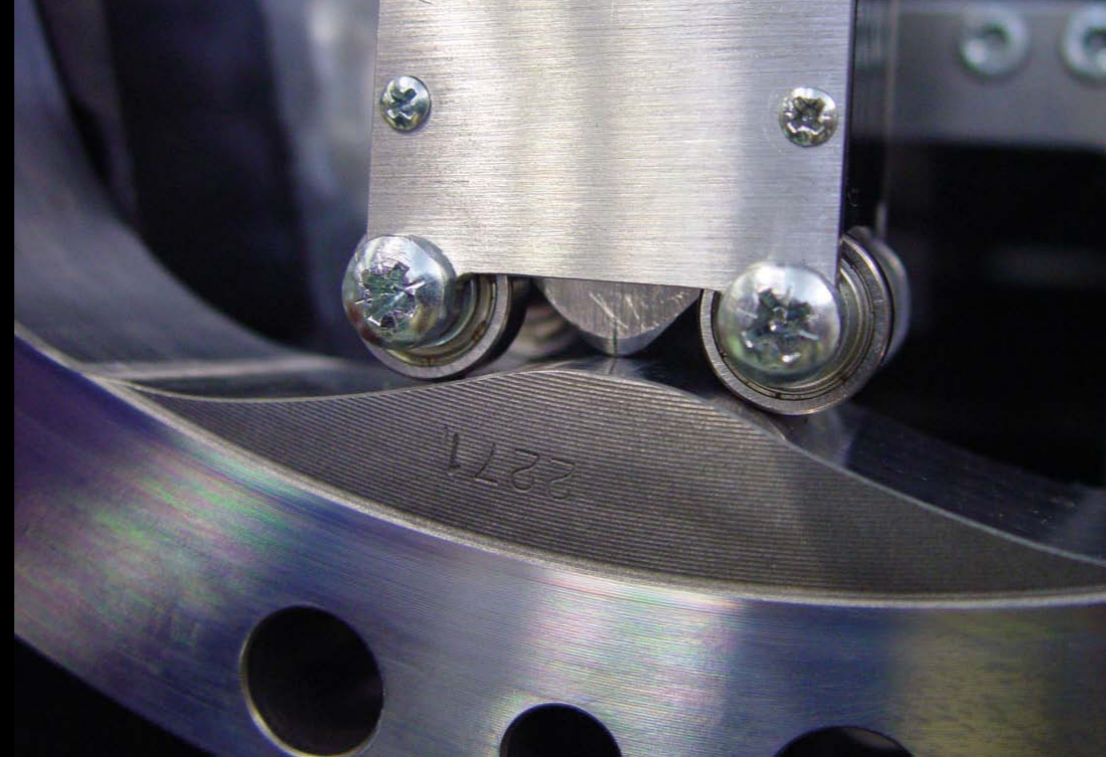

BLACK BRUIN PISTON TECHNOLOGY

OPTIMUM PERFORMANCE

HIGHLIGHTS:

- Wear-free piston design – no harmful particles into system
- Constant high torque throughout the turning range
- Precise control
- Durable construction
- Long service life with torque that lasts

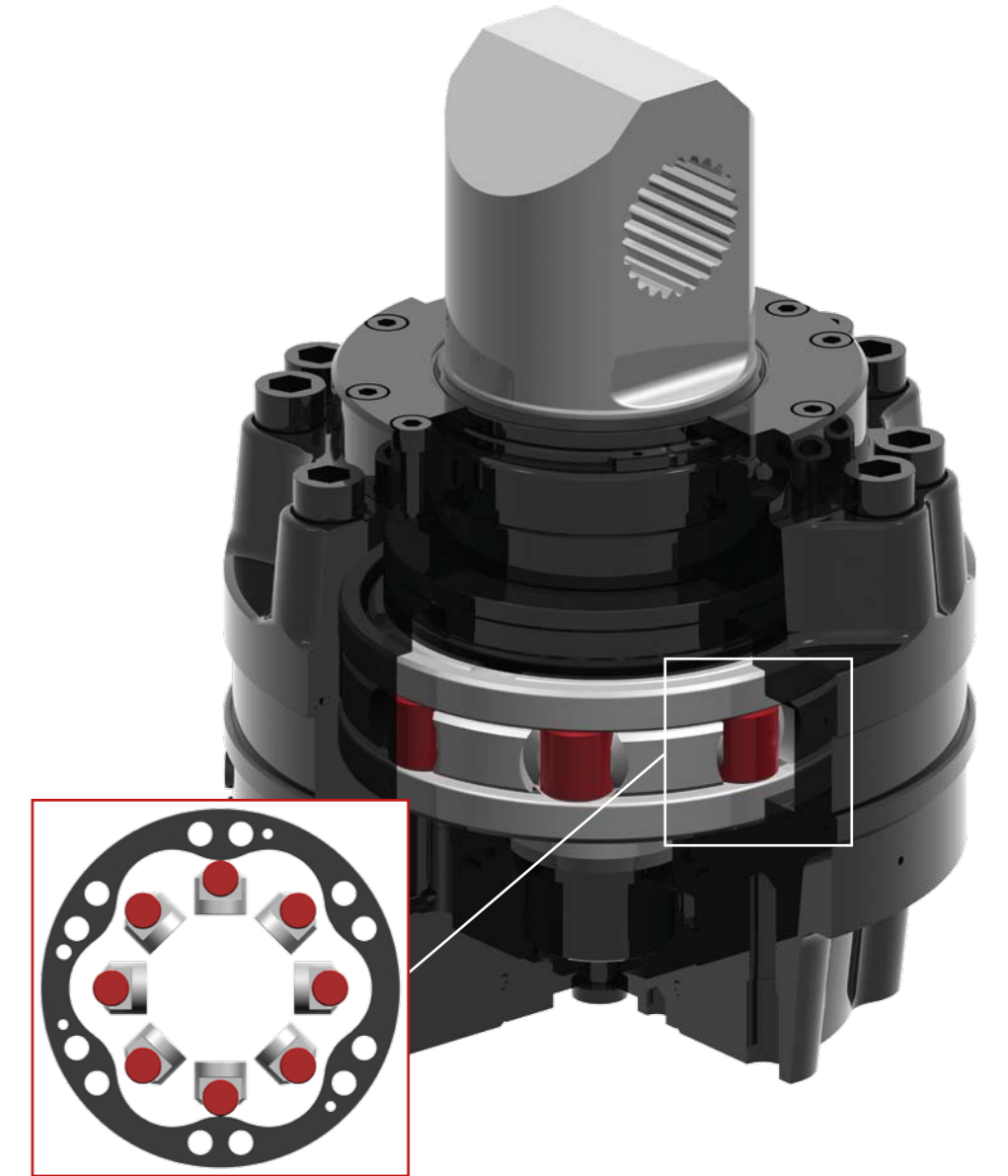

SUPERIOR, LONG LASTING TORQUE

A good rotator is one that is easy to use, rugged, and above all, dependable in extreme conditions. Black Bruin rotators meet all of this criteria – and many others into the bargain. Their superior technical performance has gained the unreserved regard of professionals all over the world.

DURABILITY GUARANTEED

The key to the popularity of Black Bruin rotators is piston technology. Due to durable piston design, the rotator is very accurate in its operation. The radial piston-cam curve design

is precisely balanced, providing a constant ripple-free output torque. High torque is achieved with small oil flow and it remains constant throughout the turning range.

Accurate Black Bruin rotator maintains torque characteristics throughout its long service life. This means productive and efficient contracting!

“ Accuracy, strength and endurance are the key features a rotator must have. We developed the radial piston structure of our Black Bruin rotators precisely for this. With our special design, Black Bruin rotators provide superior efficiency, and maintain their characteristics in the long run.

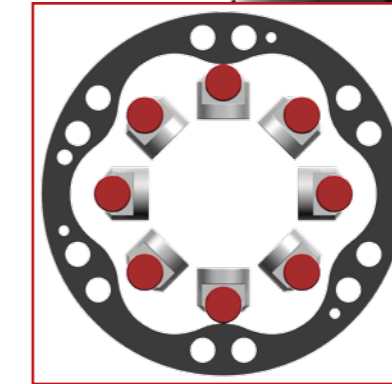
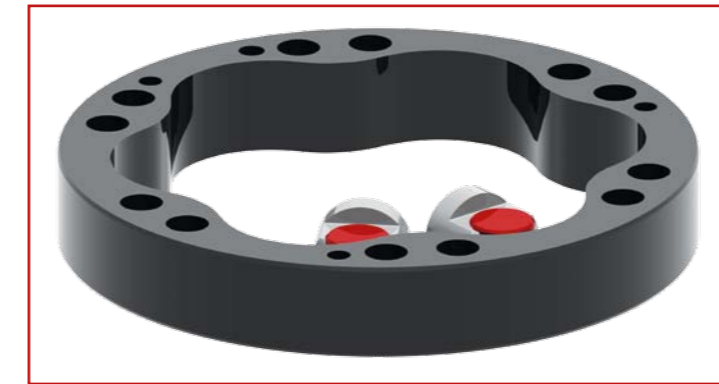



BLACK BRUIN HARVESTER ROTATORS

BBR H / RH3016

HIGHLIGHTS:

- Case drain line for maximal performance
- Excellent load capacity in radial and axial direction
- Constant high torque throughout the turning range
- Built-in relief valves protect the hydraulic system
- All-season sealing for demanding work environments



BBR H SERIES

BBR H rotator for harvester heads makes forest harvesting efficient. You can trust its durability and usability, thanks to its excellent load capacity and constant high torque throughout the turning range.

The highly recommended case drain line guarantees maximal power. Low case pressure ensures long bearing and seal service life.

BBR H stands for power, reliability and productivity for all harvester head applications.

RH3016

RH3016 is the most powerful Black Bruin rotator to date. With high torque, it is the top choice for heavy-duty harvesting, when productivity, strength and endurance are required. The durable bearing design, added with the benefits of case drain line handles the most demanding loads.

The robust RH3016 maintains its performance in the long run. Operating is precise and reliable. The sealing solution is easy to service for higher productivity.



ROTATOR	BBR 08H	BBR 15H	BBR 16H	RH3016
Application	Small size harvesters	Mid-size harvesters	Large harvesters	Large harvesters
Max. torque [Nm]	1600	3000	3000	3480
Axial load capacity [kN]	80	150	160	160
Weight [kg]	47	57	65	66
Compatible link type	H-074	H-080	H-085	



BLACK BRUIN LINKS

H-074 / H-080 / H-085

HIGHLIGHTS:

- Light and compact construction
- Various types for harvester use
- 1J – single brake, lower
- 2J – dual brake, upper and lower
- 2K – dual brake, upper and lower (with option for symmetric lower brake)

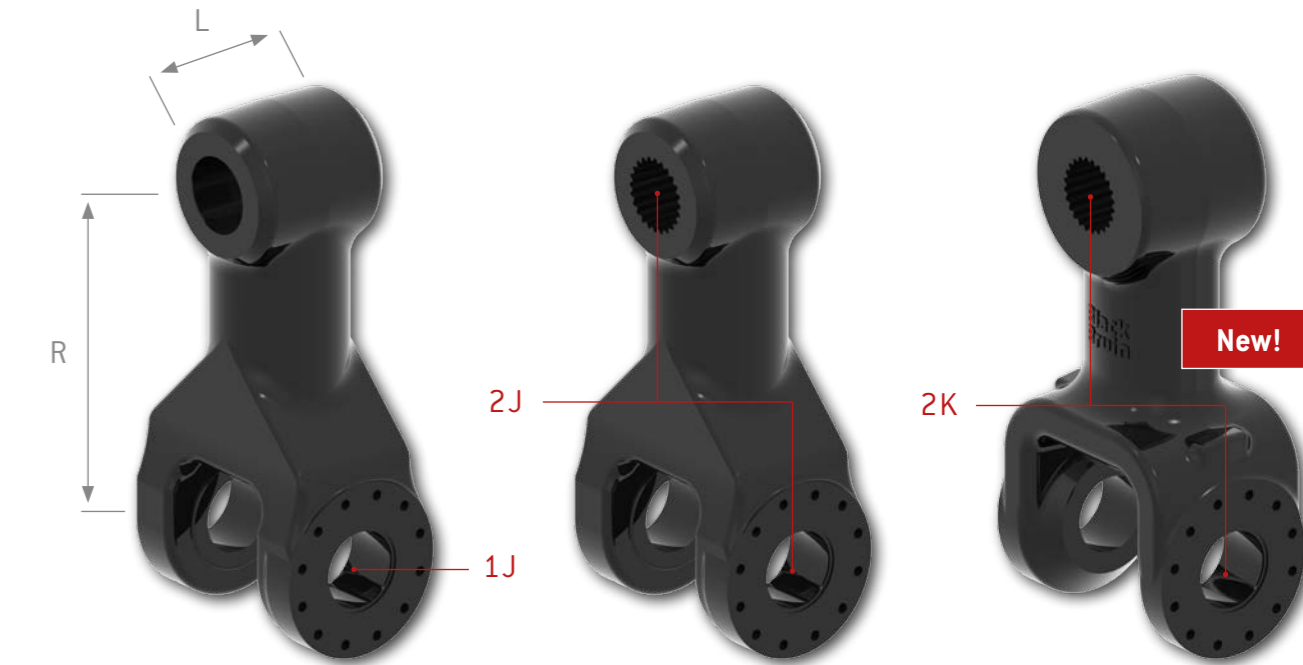

ADVANCED LINK OPTIONS

Black Bruin offers a variety of links, suitable for many types of cranes. Links can be equipped with single or dual multi-disc brakes.

APPLICATION REQUIREMENTS

Light brake link guarantees smooth working by damping the harvester head swinging efficiently. Dual brake link offers damping in both directions. You can select single or dual brake link to best fit your application requirements.

TR LINKS New!

With TR links, the brakes can be fitted symmetrically on both sides of the link. You'll get more compact overall structure with higher brake torque. See page 11 for more details.



LINK / ROTATOR	H-074 (BBR 08H)			H-080 (BBR 15H)			H-085 (BBR 16H / RH3016)	
Main dimensions	R155.L080 2J	R240.L080 1J R240.L080 2J	R240.L100 1J R240.L100 2J	R155.L100 1J R155.L100 2J	TR240.L100 2K *	TR310.L100 2K *	TR240.L100 2K *	TR310.L100 2K *
Weight [kg]	12,6	14,5	15,2	13,5	19,7	22,7	19,9	23,0

Ordering code example: H-080 R240.L100 2J. *Consult the manufacturer for TR links with single brake (lower) option only.

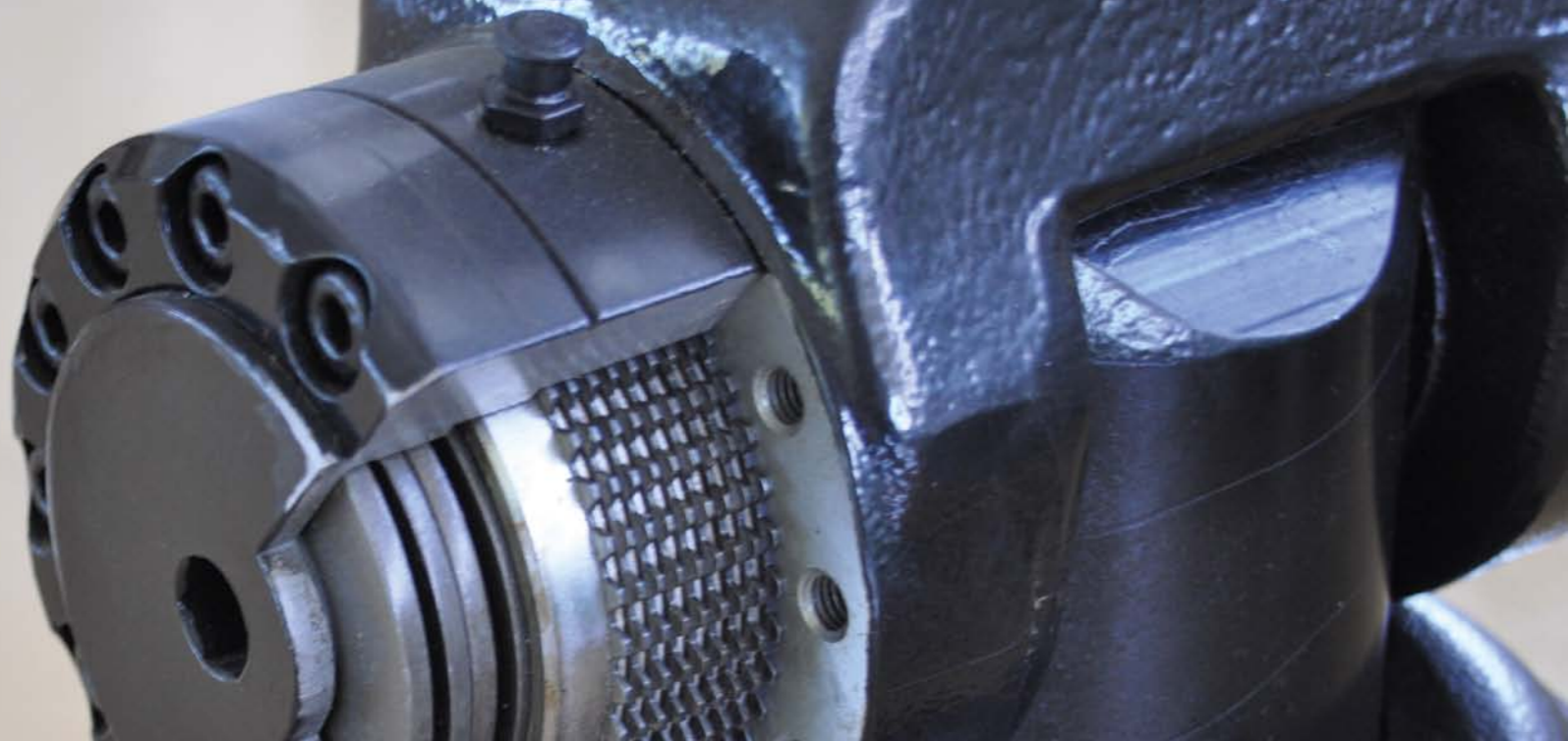

MULTI-DISC BRAKE DAMPING

Black Bruin rotators can be equipped with one or two multi-disc brakes. Black Bruin brakes increase the rotator's value to the user. Brake guarantees smooth working by damping the harvester head swinging efficiently.

pre-adjusted mechanically or continuously controlled by hydraulics.

Unique multi-disc design is wear-proof and easy to service, thus giving the long operational life with constant braking force.

Wide range of Black Bruin damping solutions offer an alternative for any working conditions. Brake torque is either

BLACK BRUIN BRAKES

S / X / SH / XH

HIGHLIGHTS:

- Unique multi-disc design
- Durable brake discs – constant braking force
- Well-protected and service friendly structure
- Long maintenance interval
- Spring loaded or hydraulically controlled models

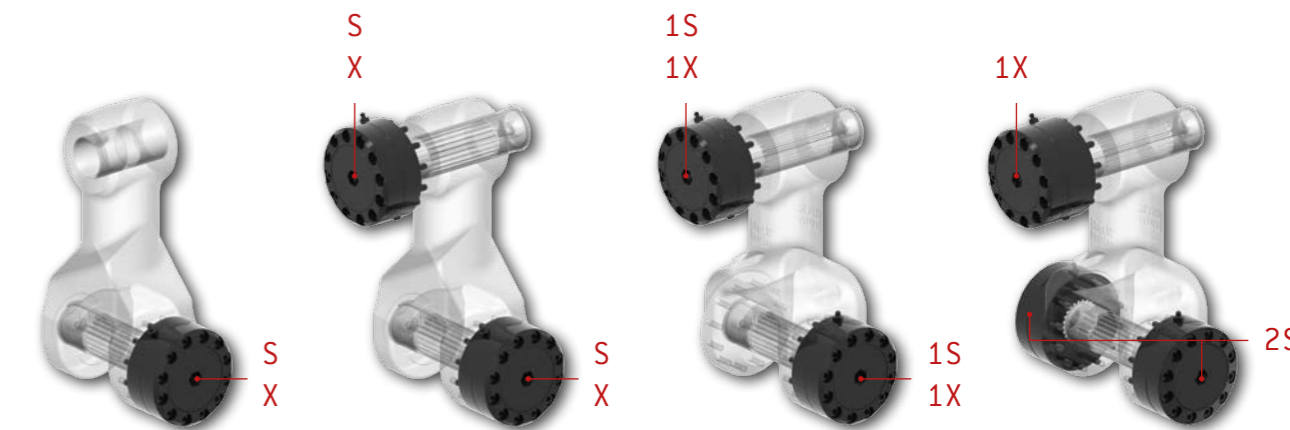

BRAKE STRUCTURE FOR R-LINKS

BRAKE STRUCTURE FOR TR-LINKS

New!

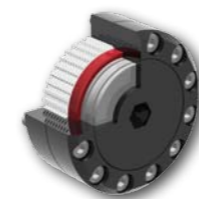

Spring loaded

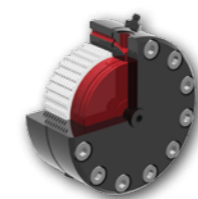

Hydraulically controlled



BRAKE	S	2S (symmetric) ^{a)}	X	SH	XH
Type	spring loaded, adjustable multi-disc			hydraulically controlled multi-disc	
Brake torque [Nm]	800...1100	1600...2200	1300...1750	0...1100	0...1750
Weight [kg]	3,2	6,4	4,4	3,2	4,4

a) Brake can be installed symmetrically only for TR-links.



ENHANCED PRECISION

The hydraulically controlled swing damper is the newest addition of the Black Bruin rotator family. It makes the control of the harvester head extremely versatile and boosts work efficiency.

Braking force can be easily controlled by the user and a harvester head locked to any position, allowing tree to be grappled precisely and efficiently. This is a valuable feature in forest thinnings and multi-tree handling, when harvester head needs to be maneuvered between trees.

The operating pressure is delivered to upper brake and led to lower brake through link's internal channel. No additional damage prone hoses are required.

The braking force remains constant throughout the rotator's operating life. This also reduces the brake wear, and there is no need for adjustment.

Compact Black Bruin swing damper with powerful radial piston rotator is an unbeatable combination!

“ We constantly monitor our rotators at work in real-world conditions. We see and hear what our clients and end-users need, and how our rotators can be developed to meet those needs. This is why Black Bruin rotators truly help people perform their every day work better.

BLACK BRUIN HYDRAULICALLY CONTROLLED SWING DAMPER

FOR BBR 15H / BBR 16H / RH3016

HIGHLIGHTS:

- Compact construction with precise control = efficiency and productivity
- Less strain on boom
- No additional hoses are required
- Braking force applied as needed – precise control and manoeuvrability
- Low brake disc wear – no need for adjustment
- Holds braking force throughout the service life

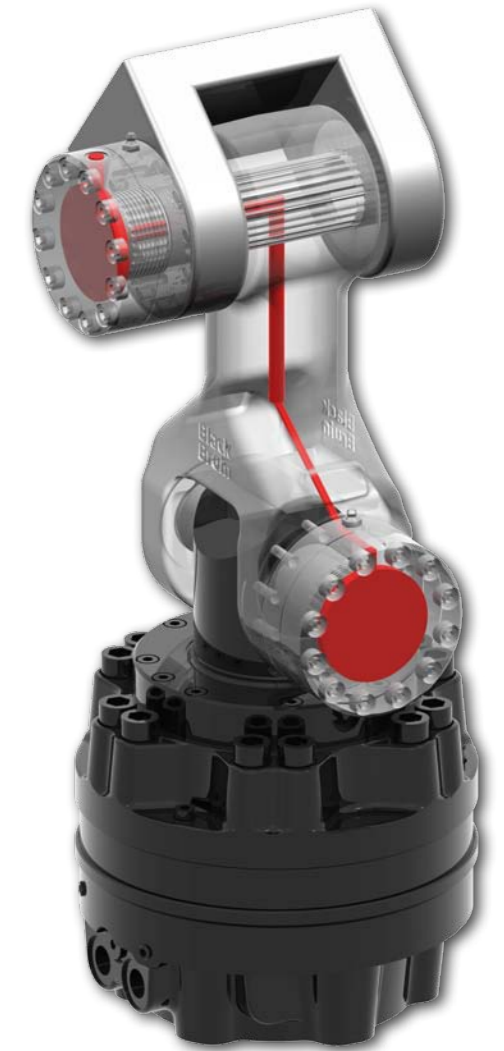

COMPATIBLE MODELS			
ROTATOR	BBR 15H*	BBR 16H*	RH3016*

* Retrofitting is possible.

BLACK BRUIN ORDERING CODE

ROTATORS / LINKS / BRAKES

ORDERING CODE EXAMPLES:

ROTATOR	LINK	LOWER BRAKE	UPPER BRAKE
BBR 15H	H-080 R155.L100 1J	S	
BBR 15H	H-080 R155.L100 2J	S	S

ROTATOR	LINK	LOWER BRAKE	UPPER BRAKE
BBR 15H	H-080 TR240.L100 2K	1S	1S
BBR 15H	H-080 TR240.L100 2K	2S (symmetric)	1X

ROTATOR	LINK							BRAKE				
	H-074		H-080			H-085		S	2S (symmetric)	X	SH	XH
	R155.L080 2J	R240.L080 1J R240.L080 2J	R240.L100 1J R240.L100 2J	R155.L100 1J R155.L100 2J	TR240.L100 2K	TR310.L100 2K	TR240.L100 2K					
BBR 08H
BBR 15 H			
BBR 16H						
RH3016						

When ordering rotator, link or brake separately, the correct pin kit is always required for assembly.

BLACK BRUIN ORDERING CODE

PIN KITS

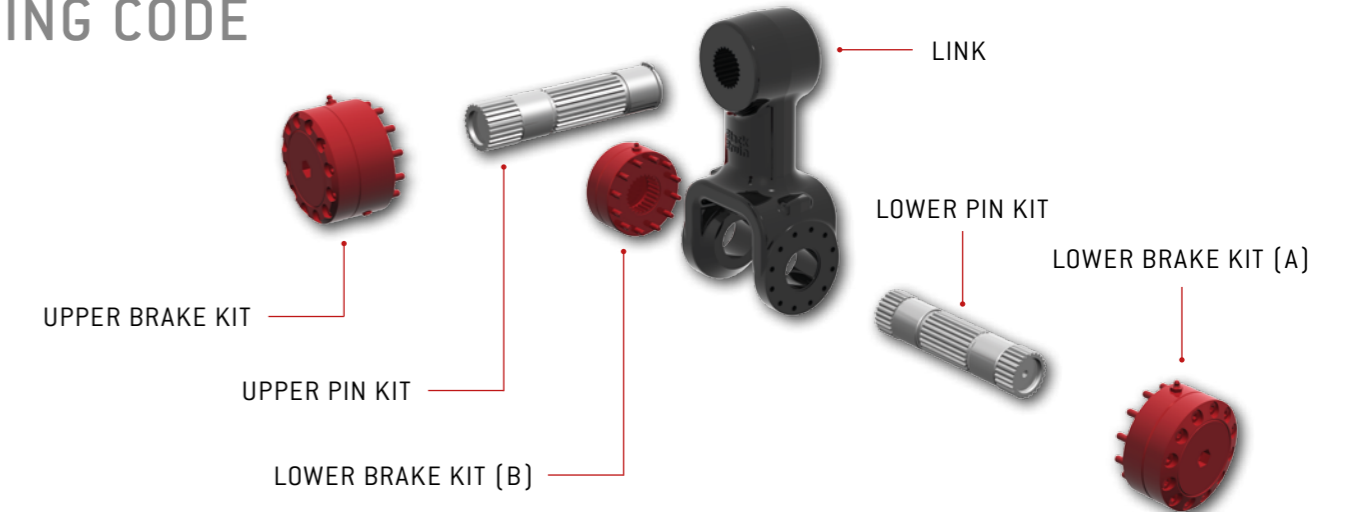

LINK / ROTATOR	LINK MAIN DIMENSIONS	BRAKE S / SH		BRAKE X / XH		BRAKE 2S (symmetric)
		UPPER PIN KIT	LOWER PIN KIT	UPPER PIN KIT	LOWER PIN KIT	LOWER PIN KIT
H-074 BBR 08H	R155.L080 2J	D45.L080.W161.J25	D35.D45.L074.W155.J25			
	R240.L080 1J		D35.L074.W155.J25		D35.L074.W155.J40	
	R240.L080 2J	D45.L080.W161.J25	D35.L074.W155.J25	D45.L100.W181.J40	D35.L074.W155.J40	
	R240.L100 1J		D35.L074.W155.J25		D35.L074.W155.J40	
H-080 BBR 15H	R240.L100 2J	D45.L100.W181.J25	D35.L074.W155.J25	D45.L100.W181.J40	D35.L074.W155.J40	
	R155.L100 1J		D45.L080.W161.J25		D45.L080.W161.J40	
	R155.L100 2J	D45.L100.W181.J25	D45.L080.W161.J25	D45.L100.W181.J40	D45.L080.W161.J40	
	TR240.L100 2K	D45.L100.W181.J25	D45.L080.W161.J25	D45.L100.W181.J40	D45.L080.W161.J40	D45.L080.W162.K25
H-085 BBR 16H / RH3016	TR310.L100 2K	D45.L100.W181.J25	D45.L085.W166.J25	D45.L100.W181.J40	D45.L085.W166.J40	D45.L085.W167.K25
	TR240.L100 2K	D45.L100.W181.J25	D45.L085.W166.J25	D45.L100.W181.J40	D45.L085.W166.J40	D45.L085.W167.K25

Please note! The correct pin kit is always required for a complete rotator assembly.

INNOVATIVE HYDROSTATIC TRANSMISSION AND ROTATION SOLUTIONS

Sampo Hydraulics Ltd. is one of the world's leading suppliers of radial piston hydraulic motors and rotators. Our trade mark Black Bruin offers a high quality solution for agriculture, construction and mining, road building and forestry equipment applications. As an international operator located in Jyväskylä, Central Finland, we employ more than 100 fully trained professionals and have a distribution network which covers over 25 countries.

■ Manufacturing ■ Distributor

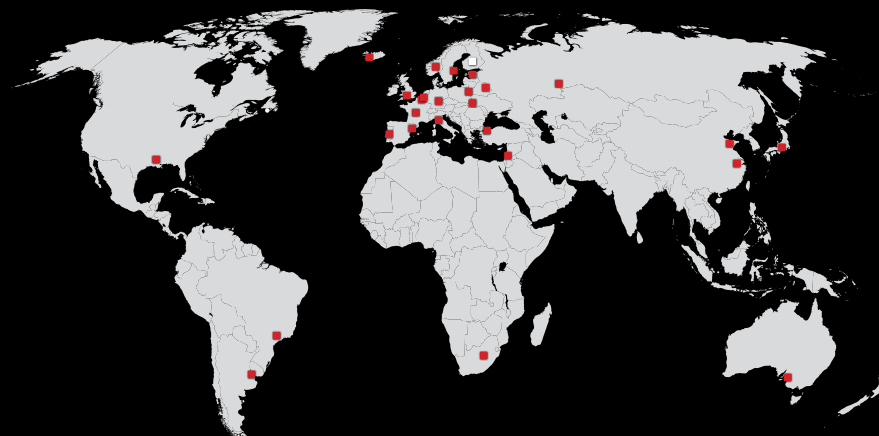

**Black
Bruin**

No power like it.