

BRINKMANN Immersion Pumps

TH/STH11...TH/STH17



Brinkmann Pumpen
K. H. Brinkmann GmbH & Co. KG
Friedrichstraße 2 D-58791 Werdohl
Tel.: +49-2392 / 5006-0
Fax.: +49-2392 / 5006-180

www.brinkmannpumps.de
sales@brinkmannpumps.de

Subject to change without prior notice.

Order - No. : BE3914 ENGLISH

Brinkmann Immersions pumps of the series TH/STH11 ... TH/STH17

Contents

1	Indication to the manual	2	9	Trouble shooter's guide.....	12
2	Description of product	2	10	Spare part	13
3	Safety instructions	9	11	Repair	15
4	Transport and storage	9	12	Disposal	15
5	Installation and Connection	10	13	Declarations of conformity.....	16
6	Start up / Shut down.....	11			
7	Operation.....	11			
8	Servicing and Maintenance	11			

1 Indication to the manual

This operating manual gives basic instructions which are to be observed during installation, operation and maintenance of the pump. It is therefore imperative that this manual be read by the responsible personnel and operator prior to assembly and commissioning. It is always to be kept available at the installation site.

1.1 Identification of safety instructions in the operating manual

Safety instructions given in this manual non-compliance with which would affect **safety** are identified by the following symbol



Safety sign according with ISO 3864 – B.3.1

or where **electrical safety** is involved, with:



Safety sign according with ISO 3864 – B.3.6

Where non-compliance with the safety instructions may cause a risk to the machine and it's function the word

ATTENTION

is inserted.

2 Description of product

2.1 General description of the pump

Pumps of this type are multi-stage rotary pumps. Series TH/STH use closed impellers in order to minimizing power consumption and to optimize hydraulic pump efficiencies. In addition, the TH/STH series offers high pressures at short immersion depths.

The pump shaft and the motor shaft are connected by a coupling. The pump shaft is sealed by a rotating mechanical seal. The pump is protected again impurity by a filter. Pump and motor form a compact and space-saving unit.

Vertically mounted pumps are equipped with a mounting flange. The pump end immerses into the tank and the motor extends vertically above the tank.

2.2 Intended use

The TH/STH pumps are suitable for supplying fluids to internally cooled tools and cooling and temperature control circuits in technical systems.

Observe the operating limits shown in Table 1.

Limit of Application (Table 1)

Type	TH/STH11...17
Mediums	Industry water, cooling emulsions, cooling- and cutting-oils
Kinetic viscosity of the medium	...25 mm ² /s
Temperature of medium	0 ... 80 °C
Particle-size in the medium	1 mm
max. operation pressure	27 bar
min. delivery volume	(S)TH11 42 / 50 (S)TH14 67 / 84 50 / 60 Hz (S)TH17 92 / 109 in l/min at special execution -Q 1% of Q max.
Dry running	The pumps are not suitable for dry running.
Switching-on frequency per hour	Motors less 3 kW max. 200 from 3 kW to 4.0 kW max. 40 from 5.0 kW to 10.3 kW max. 20 Motors 11 kW and higher max. 15
Ambient temperature	40 °C
Set-up altitude	1000 m

ATTENTION

The pumps are to be operated within their design limits. Applications outside of these limits are not approved. The manufacturer is not responsible for any damages resulting from use of the pumps in such applications.

2.3 Type Designation

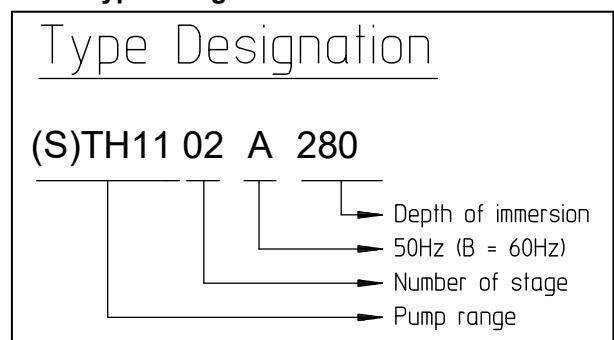

Technical data

50 Hz

Type	Max. del. pressure bar / spec. weight 1	Max. del. volume l/min	Height ¹⁾ H mm	Depth of immersion ¹⁾ h mm	Weight TH ²⁾ kg	Power kW	Noise level ³⁾ dBA
(S)TH1102A180	2.1	250	433	182	34	1.3	63
(S)TH1103A180	3.8	250	433	182	35	1.5	63
(S)TH1104A280	4.8	250	459	278	39	1.7	63
(S)TH1105A280	5.9	255	492	278	43	1.9	63
(S)TH1106A280	7.0	260	492	278	45	2.6	63
(S)TH1107A310	8.0	265	531	310	55	3.0	71
(S)TH1108A380	9.2	280	531	374	58	3.3	71
(S)TH1109A380	10.7	280	531	374	59	4.0	71
(S)TH1110A470	11.9			470	60		
(S)TH1111A470	13.0	285	561	470	67	5.0	71
(S)TH1112A470	14.0				68		
(S)TH1113A500	15.2	290	561	502	69	5.5	71
(S)TH1114A570	16.3			566	71		
(S)TH1115A570	17.8	295	640	566	101	7.5	74
(S)TH1116A660	19.0			662	103		
(S)TH1117A660	20.0				104		
(S)TH1118A660	21.2				105		
(S)TH1119A760	22.4	300	640	758	110	9.0	74
(S)TH1120A760	23.8				112		
(S)TH1121A760	25.0				115		

1) Dimensions in accordance with page 10

2) Weight STH = Weight TH + 2 kg

3) Noise emissions measured in accordance with
DIN 45635 at a distance of 1 m

The motor is surface-cooled and compliant with
DIN IEC 34 and EN 60034 (protection degree IP 55).

50 Hz

Type	Max. del. pressure bar / spec. weight 1	Max. del. volume l/min	Height ¹⁾ H mm	Depth of immersion ¹⁾ h mm	Weight TH ²⁾ kg	Power kW	Noise level ³⁾ dBA
(S)TH1402A180	2.8	420	459	182	37	1.7	63
(S)TH1403A280	4.1	425	492	278	43	2.6	63
(S)TH1404A280	5.9	445	531	278	55	3.3	71
(S)TH1405A380	7.2	455	531	374	57	4.0	71
(S)TH1406A380	8.4	465	561	374	64	5.0	71
(S)TH1407A470	10.0	475	561	470	66	5.5	71
(S)TH1408A470	11.8	475	640	470	98	7.5	74
(S)TH1409A570	12.1			566	102		
(S)TH1410A570	14.3	485	640	566	110	9.0	74
(S)TH1411A660	16.0			662	115		
(S)TH1412A660	17.6	490	647	662	131	11.0	74
(S)TH1413A760	19.0			758	135		
(S)TH1414A760	20.1	500	647	758	139	13.0	74
(S)TH1415A900	21.9			902	143		
(S)TH1416A900	23.2				145		
(S)TH1417A900	24.8	500	952	902	155	15.0	78

1) Dimensions in accordance with page 10

2) Weight STH = Weight TH + 2 kg

3) Noise emissions measured in accordance with
DIN 45635 at a distance of 1 m

The motor is surface-cooled and compliant with
DIN IEC 34 and EN 60034 (protection degree IP 55).

50 Hz

Type	Max. del. pressure bar / spec. weight 1	Max. del. volume l/min	Height ¹⁾ H mm	Depth of immersion ¹⁾ h mm	Weight TH ²⁾ kg	Power kW	Noise level ³⁾ dBA
(S)TH1702A180	3.1	500	492	182	42	2.2	63
(S)TH1703A280	4.3	500	531	278	55	3.3	71
(S)TH1704A280	6.0	500	561	278	61	5.0	71
(S)TH1705A380	7.7	505	561	374	64	5.5	71
(S)TH1706A380	9.1	505	640	374	87	7.5	74
(S)TH1707A470	10.4			470	97		
(S)TH1708A470	12.0	510	640	470	116	9.0	74
(S)TH1709A570	13.7	520	647	566	124	11.0	74
(S)TH1710A570	15.0				126		
(S)TH1711A660	16.4	535	647	662	128	13.0	74
(S)TH1712A660	18.0				129		
(S)TH1713A760	19.7	535	952	758	150	15.0	78
(S)TH1714A760	21.2	535	1002	758	168	18.5	78
(S)TH1715A900	22.4	555		902	170		
(S)TH1716A900	24.0				172		
(S)TH1717A900	25.2				175		

1) Dimensions in accordance with page 10

2) Weight STH = Weight TH + 2 kg

3) Noise emissions measured in accordance with
DIN 45635 at a distance of 1 m

The motor is surface-cooled and compliant with
DIN IEC 34 and EN 60034 (protection degree IP 55).

60 Hz

Type	Max. del. pressure bar / spec. weight 1	Max. del. volume l/min	Height ¹⁾ H mm	Depth of immersion ¹⁾ h mm	Weight TH ²⁾ kg	Power kW	Noise level ³⁾ dBA
(S)TH1102B180	3.4	275	433	182	34	1.49	66
(S)TH1103B180	5.2	285	492	182	43	2.18	66
(S)TH1104B280	6.8	290	492	278	44	2.94	66
(S)TH1105B280	8.2	300	531	278	57	3.8	74
(S)TH1106B280	10.1	310	531	278	58	4.55	74
(S)TH1107B310	11.9	320	561	310	62	5.75	74
(S)TH1108B380	13.8	325		374	64		
(S)TH1109B380	15.6	330	561	374	65	6.3	74
(S)TH1110B470	17.2	330	640	470	97	8.6	77
(S)TH1111B470	19.0	335			98		
(S)TH1112B470	20.4	340			99		
(S)TH1113B500	22.1	340	640	502	108	10.3	77
(S)TH1114B570	23.8	350		566	109		
(S)TH1115B570	25.0	350			110		

1) Dimensions in accordance with page 10

2) Weight STH = Weight TH + 2 kg

3) Noise emissions measured in accordance with
DIN 45635 at a distance of 1 m

The motor is surface-cooled and compliant with
DIN IEC 34 and EN 60034 (protection degree IP 55).

60 Hz

Type	Max. del. pressure bar / spec. weight 1	Max. del. volume l/min	Height ¹⁾ H mm	Depth of immersion ¹⁾ h mm	Weight TH ²⁾ kg	Power kW	Noise level ³⁾ dBA
(S)TH1402B180	4.0	460	492	182	47	2.94	66
(S)TH1403B280	6.0	475	531	278	58	4.55	74
(S)TH1404B280	8.1	490	561	278	65	6.3	74
(S)TH1405B380	10.2	500	640	374	94	8.6	77
(S)TH1406B380	12.2	510			95		
(S)TH1407B470	14.4	520	640	470	108	10.3	77
(S)TH1408B470	16.4	530	647	470	123	12.6	79
(S)TH1409B570	18.6	545	647	566	127	15.0	79
(S)TH1410B570	20.8	550			128		
(S)TH1411B660	22.8	560	952	662	157	17.3	81
(S)TH1412B660	25.0	570			160		

1) Dimensions in accordance with page 10

2) Weight STH = Weight TH + 2 kg

3) Noise emissions measured in accordance with
DIN 45635 at a distance of 1 m

The motor is surface-cooled and compliant with
DIN IEC 34 and EN 60034 (protection degree IP 55).

60 Hz

Type	Max. del. pressure bar / spec. weight 1	Max. del. volume l/min	Height ¹⁾ H mm	Depth of immersion ¹⁾ h mm	Weight TH ²⁾ kg	Power kW	Noise level ³⁾ dBA
(S)TH1702B180	4.1	550	531	182	55	3.8	74
(S)TH1703B280	6.4	555	561	278	60	5.75	74
(S)TH1704B280	8.4	570	640	278	86	8.6	77
(S)TH1705B380	10.8	580	640	374	115	10.3	77
(S)TH1706B380	13.1	600	647	374	118	12.6	79
(S)TH1707B470	15.2	605	647	470	122	15.0	79
(S)TH1708B470	17.4	610			123		
(S)TH1709B570	19.7	620	952	566	148	17.3	81
(S)TH1710B570	21.8	630	1002	566	160	21.3	81
(S)TH1711B660	24.0	640		662	161		

1) Dimensions in accordance with page 10

2) Weight STH = Weight TH + 2 kg

3) Noise emissions measured in accordance with
DIN 45635 at a distance of 1 m

The motor is surface-cooled and compliant with
DIN IEC 34 and EN 60034 (protection degree IP 55).

3 Safety instructions

When operating the pump, the safety instructions contained in this manual, the relevant national accident prevention regulations and any other service and safety instructions issued by the plant operator are to be observed.

3.1 Hazards in the event of non-compliance with the safety instructions

Non-compliance with the safety instructions may produce a risk to the personnel as well as to the environment and the machine and results in a loss of any right to claim damages.

For example, non-compliance may involve the following hazards:

- Failure of important functions of the machines/plant
- Failure of specified procedures of maintenance and repair
- Exposure of people to electrical, mechanical and chemical hazards
- Endangering the environment due to hazardous substances being released

3.2 Unauthorized modes of operation



- Pump may not be used in potentially explosive environments!
- Pump and discharge piping are not designed to hold any weight and may not be used as a step ladder.

3.3 Remaining Risk



Risk of Injury!

Risk of squeezing or crushing body parts when installing or removing the pump exists. Proper and secured lifting tools must be used.

Risk of burns!

The pump must have cooled down sufficiently prior to commencing any repair, maintenance or installation.

3.4 Qualification and training of operating personnel

The personnel responsible for operation, maintenance, inspection and assembly must be adequately qualified. Scope of responsibility and supervision of the personnel must be exactly defined by the plant operator. If the staff does not have the necessary knowledge, they must be trained and instructed, which may be performed by the machine manufacturer or supplier on behalf of the plant operator. Moreover, the plant operator is to make sure that the contents of the operating manual are fully understood by the personnel.

3.5 Safety instructions relevant for operation

- If hot or cold machine components involve hazards, they must be guarded against accidental contact.
- Guards for moving parts (e.g. coupling) must be installed with the machine in operation.
- Any leakage of hazardous (e.g. explosive, toxic, hot) fluids (e.g. from the shaft seal) must be drained away so as to prevent any risk to persons or the environment. Statutory regulations are to be complied with.
- Hazards resulting from electricity are to be prevented (see for example, the VDE Specifications and the bye-laws of the local power supply utilities).
- The pumps' stability against falling over is not ensured unless it is properly mounted onto the tank.
- The female threads on the motor MUST NOT be used to lift the entire pump and motor assembly.

3.6 Safety instructions relevant for maintenance, inspection and assembly work

Any work on the machine shall only be performed when it is at a standstill, it being imperative that the procedure for shutting down the machine described in this manual be followed.

Pumps and pump units which convey hazardous media must be decontaminated.

On completion of work all safety and protective facilities must be re-installed and made operative again.

Prior to restarting the machine, the instructions listed under "Start up" are to be observed.

3.7 Signs on the pump

It is imperative that signs affixed to the machine, e.g.:

- arrow indicating the direction of rotation
 - symbols indicating fluid connections
- be observed and kept legible.

3.8 Unauthorized alterations and production of spare parts

Any modification may be made to the machine only after consultation with the manufacturer. Using spare parts and accessories authorized by the manufacturer is in the interest of safety. Use of other parts may exempt the manufacturer from any liability.

4 Transport and storage

Protect the pump against damage when transporting.

The pumps may only be transported in a horizontal position and hooks or straps must be attached on the motor and pump end.

Do not use the pump shaft for connecting any transportation aids such as hooks or straps.

Pumps must be drained prior to their storage.

Store pump in dry and protected areas and protect it against penetration of foreign bodies.

Always store pump above the freezing point!

5 Installation and Connection

5.1 Mechanical installation

During any assembly or disassembly process the pumps must be secured against tipping through ropes for example at all times.

Pumps must be mounted securely. Piping, tank and pumps must be mounted without any tension.

The inlet is at the bottom of the immersed pump body. The distance between the inlet and the tank bottom must be so large that the inlet cannot be blocked by deposits during longer shutdowns.

The leakage is collected in a leakage chamber and drained off by the leakage hole into the tank. During the assembling of the pump, be sure that the leakage hole is free.

To obtain the full flow rate it is recommended to choose for the pipework the nominal bore diameter of the pumps cross section for connection. Therefore pipe bends should be used, not pipe angles!

The pipework must be qualified for occurring hydraulic pressure.

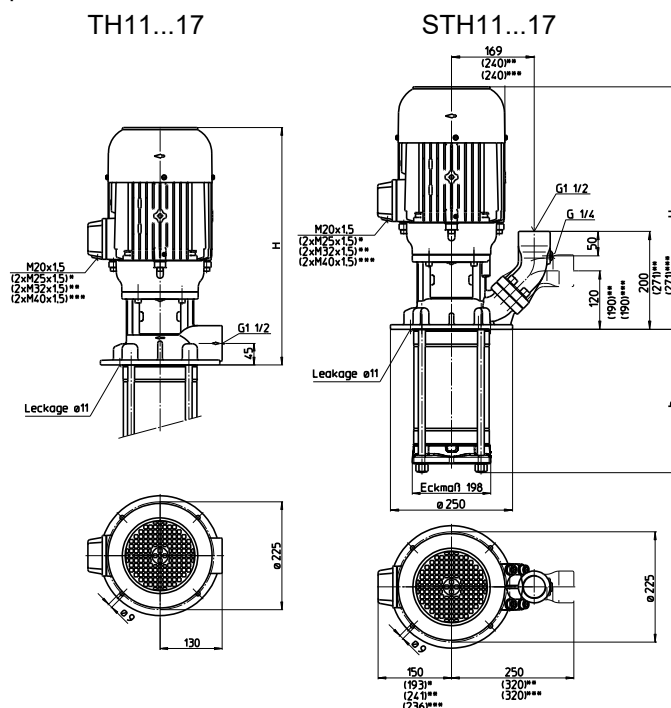

*) Dimensions for 7.5 to 10.3 kW ; **) Dimensions for 11.0 / 13.0 kW and 15 kW 60 Hz

***) Dimensions for 15.0 kW 50 Hz to 21.3 kW

ATTENTION

Pay attention of the max. tightening torque for piping connection

Type	Pipe connection	Cast iron
TH11...17	G 1 1/2	150 Nm
STH11...17	G 1 1/2	150 Nm

When installed the space around the pump must be large enough to provide sufficient cooling of the motor.

Do not prop up the pressure line via the joining socket.



The pump must be mounted in that way that rotating parts under the cover of the coolant tank can not be touched!

5.2 Electric wiring



All service work must be carried out by qualified service personnel. Pump must be disconnected from the power source and all rotating parts must stand still. Reassure that pump is disconnected from power source and cannot be switched on. Verify that there is no voltage at the terminal board!

According to the European Standard EN809 a motor overload must be installed and properly set to the full load amps stated on the pump name plate.

It is the responsibility of the machine operator to decide whether or not an additional emergency switch must be installed.



Danger!

Risk of electric shock

Our asynchronous motors can optionally be fitted with temperature sensors in the form of triplet PTC thermistors, which are used for thermal monitoring of the motor windings. Please note that the temperature sensors meet the insulation requirements of basic insulation. The improper connection of the triplet PTC thermistors to evaluation units that do not have a protective function against overvoltage in the event of a fault can lead to voltages dangerous to the touch and electric shock.

Please check whether the evaluation units you intend to use are permissible for the electrical connection of the temperature sensors.

5.2.1 Circuit



Tension voltage and frequency must correspond with the shown specification on the nameplate.

The pump must be wired so that a solid long term electrical connection is ensured. Establish a solid ground connection.

The electrical wiring must be performed according to the wiring diagram shown inside the terminal box cover. (Please see above sample wiring diagrams)

Wiring diagram e.g.

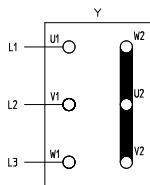

Star connection
up to 5.5 kW
3 x 400 V. 50 Hz
resp. 380-415 V. 50 Hz

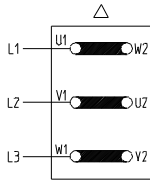

Delta connection
up to 5.5 kW
3 x 230 V. 50 Hz
resp. 220-240 V. 50 Hz
From 7.5 kW and higher
3 x 400 V. 50 Hz
resp. 380-415 V. 50 Hz

There may be no foreign objects such as dirt, particles or humidity inside the terminal board.

Mount terminal board cover to motor tight against dust and humidity and close up all unused wiring ports.

ATTENTION

When Variable Frequency Drives are used interfering signals might occur.

Non-sinus shaped supply voltage from a variable frequency drive might result in elevated motor temperatures.

6 Start up / Shut down

6.1 Start up

ATTENTION

Switch off at the mains.

After connection the electrical wires, close the terminal box. Briefly start the motor (max. 30 sec.) and check the rotation according to the arrow on the top of the motor.

If the direction is incorrect change over two of the power leads.

6.2 Shut down

All service work must be carried out by qualified service personnel. Pump must be disconnected from the power source and all rotating parts must stand still. Reassure that pump is disconnected from power source and cannot be switched on. Verify that there is no voltage at the terminal board! Open terminal box and disconnect the power leads. Empty out the pump.

7 Operation

Liquid level

Be sure that the suction hole of the pump body is immersed about 55 mm in the liquid (min. liquid level) before starting up the motor.

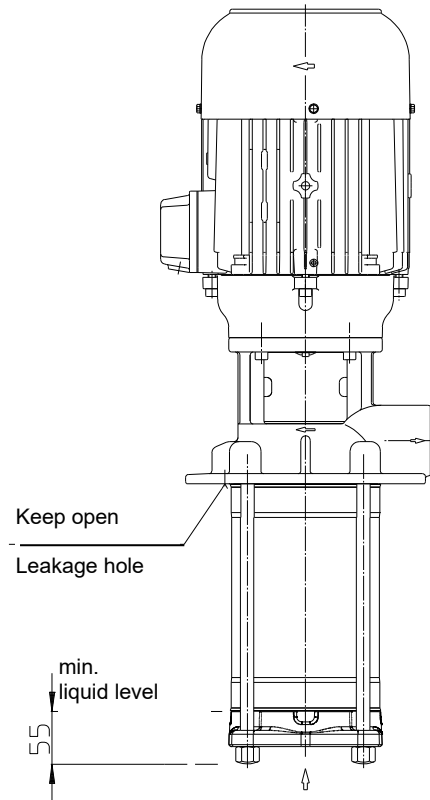

If the pump should lock up and cease, shut pump down (see 6.2) and disconnect from power supply. Pump must be uninstalled and removed from the system prior to its repair.



Attention! Potential Risk of Burning!

Surface temperatures above 50°C do occur during regular operation, i.e. on the surfaces of the motor and bearing housing.

It must be insured that the pump has cooled down sufficiently prior to performing any repair or maintenance work.

8 Servicing and Maintenance

ATTENTION

The surface of the motor must be kept free of dirt.

The motor shaft is spinning in permanently greased ball bearings (with special grease and increased bearing play) and does not require any special maintenance.

9 Trouble shooter's guide

Fault	Cause	Remedy
Motor does not start, no motor noise	At least two of the power supply leads have failed	Check fuses, terminals and supply leads.
	Overload has tripped	Inspect overload
Motor does not start, humming noise	One of the supply leads has failed	See above
	Impeller faulty Motor bearing faulty	Replace impeller Replace bearing
Overload trips	Pump locked up mechanically	Inspect pump hydraulics
	High on/of cycling frequency	Check application
Power consumption is too high	Wrong direction of rotation of impeller	See above
	Lime or other deposits mechanical friction	Clean pump mechanism repair pump
Motor overheats	High on/off cycling frequency	See above
	Wrong power supply (voltage or cycles)	Power supply must correspond with name plate rating
Pump does not pump	Insufficient cooling	Check air flow at motor fan
	liquid level too low Pump mechanism faulty Pipe blocked	Fill up liquid replace pump mechanism Clean pipe
Insufficient flow and pressure	Wrong direction of rotation of impeller	Change over two power supply leads
	Pump mechanism silted up Worn pump mechanism	Clean pump mechanism Replace pump mechanism
Incorrect flow or pressure	Wrong power supply (voltage or cycles)	Power supply must correspond with name plate rating
Running noise/Vibration	Foreign objects in pump end	Remove foreign objects
	Impeller damaged	Replace impeller
	Bearing/Bushing broken	Replace bearing/bushing

10 Spare part

10.1 Spare part list for the immersion pumps of the series TH/STH11

TH/STH1402A180...TH/STH1413A760

TH/STH1402B180...TH/STH1408B470

TH/STH1702A180...TH/STH1710A570

TH/STH1702B180...TH/STH1706B380

		Item Description	
13	9	1	Stator with terminal board
19	8	2	Motor flange
29	3	3	End shield
26	18	4	Motor shaft with rotor
27	14	5	Terminal box up to 5.5 kW
16	30	6	Terminal box frame from 7.5 kW and over
10	1	7	Terminal box cover from 7.5 kW and over
6	4	8	Fan
17	23	9	Fan cover
5	24	10	Gasket
7	25	11	Gasket from 7.5 kW and over
11	28	13	Retaining ring
15	13	13	Retaining ring 1.3...2.6 kW
21	14		DIN 471
2	15	14	Thread rolling screw
22	15		DIN 7500
88	16	15	Ball bearing
69	17	15	Ball bearing 1.3...2.6. 7.5 kW
70	18		DIN 625
76	19	16	Ball bearing
78	20		DIN 625
79	21	17	Slotted cheese head screw
80	22		DIN 84
75	23	18	Hexagon socket head cap screw
73	24		DIN 912
53	25	19	Parallel pin
57	26		DIN 7
56	27	20	Retaining ring up to 5.5 kW
60	28	21	Retaining ring up to 5.5 kW
67	29		DIN 472
64	30	22	Socket head cap screw
65	1		DIN 912
66	4	23	Bearing cover 7.5 kW and over
67	18	24	Socket head cap screw 7.5 kW
68	14		DIN 912
69	30	25	Shaft nut 7.5 kW and over
70	1	26	Compensation disk
71	4	27	O-ring
72	18	28	Shaft seal up
73	14	29	Rotary shaft seal
74	30	30	Nut up 11 kW
75	1		DIN 934
76	4	50	Pump body
77	18	51	Intake cover
78	14	52	Pump shaft
79	30	53	Diffusor with sliding ring
80	1	54	Entering stage with sliding ring
81	18	55	Outflow stage in combination with Impeller (89)
82	14	55	Spacer ring in combination with distance plate (89)
83	30	56	Bearing stage with sliding ring
84	1	57	Impeller
85	18	58	Spacer-long 2 x per stage
86	14	59	Spacer-short 1 x per bearing stage
87	30	60	Sliding ring
88	1	61	Shaft sleeve
89	18	64	Mech. Seal stop ring cover
90	14	65	Mech. seal stop half-ring
91	30	66	Mech. seal washer
92	1	67	Pump casing
93	18	68	Sieve
94	14	69	Clamp coupling
95	30	70	Coupling shield with M5 screw
96	1	71	Stud bolt
97	18	72	O-ring
98	14	73	Rotary shaft seal
99	30	74	Mechanical seal
100	1	75	Retaining ring
101	18	76	Parallel pin
102	14		DIN 7
103	30		
104	1		
105	18		
106	14		
107	30		
108	1		
109	18		
110	14		
111	30		
112	1		
113	18		
114	14		
115	30		
116	1		
117	18		
118	14		
119	30		
120	1		
121	18		
122	14		
123	30		
124	1		
125	18		
126	14		
127	30		
128	1		
129	18		
130	14		
131	30		
132	1		
133	18		
134	14		
135	30		
136	1		
137	18		
138	14		
139	30		
140	1		
141	18		
142	14		
143	30		
144	1		
145	18		
146	14		
147	30		
148	1		
149	18		
150	14		
151	30		
152	1		
153	18		
154	14		
155	30		
156	1		
157	18		
158	14		
159	30		
160	1		
161	18		
162	14		
163	30		
164	1		
165	18		
166	14		
167	30		
168	1		
169	18		
170	14		
171	30		
172	1		
173	18		
174	14		
175	30		
176	1		
177	18		
178	14		
179	30		
180	1		
181	18		
182	14		
183	30		
184	1		
185	18		
186	14		
187	30		
188	1		
189	18		
190	14		
191	30		
192	1		
193	18		
194	14		
195	30		
196	1		
197	18		
198	14		
199	30		
200	1		

10.2 Spare part list for the immersion pumps of the series

TH/STH1414A760...TH/STH1417A900
TH/STH1409B570...TH/STH1412B660

TH/STH1711A660...TH/STH1717A900
TH/STH1707B470...TH/STH1711B660

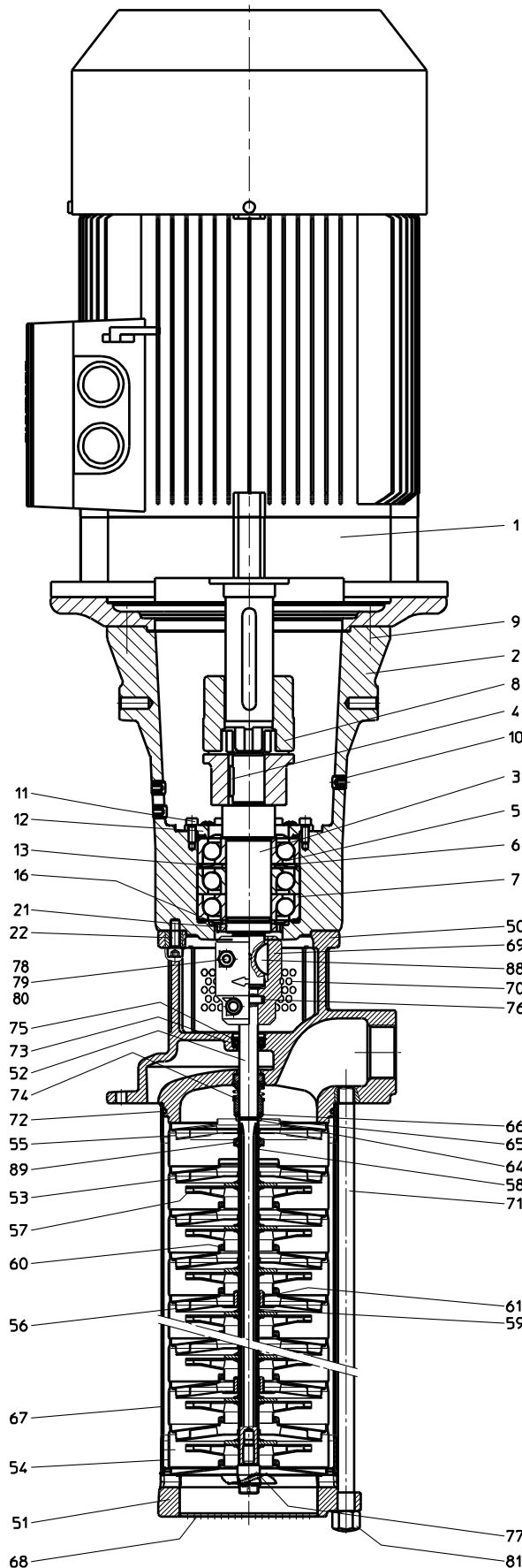

Item Description

1	Motor	
2	Bearing housing	
3	Bearing shaft	
4	Woodruff key	DIN 6888
5	Ball bearing	DIN 628
6	Distance plate	
7	Ball bearing	DIN 628
8	Coupling	
9	Socket head cap screw	DIN 912
10	Threaded pin	DIN 705
11	Bearing cover	
12	Socket head cap screw	DIN 912
13	Nilos-ring	
16	Nilos-ring	
21	Shaft nut	
22	Socket head cap screw	DIN 912
50	Pump body	
51	Intake cover	
52	Pump shaft	
53	Diffusor with sliding ring	
54	Entering stage with sliding ring	
55	Outflow stage in combination with Impeller (89)	
55	Spacer ring in combination with distance plate (89)	
56	Bearing stage with sliding ring	
57	Impeller	
58	Spacer-long 2 x per stage	
59	Spacer-short 1 x per bearing stage	
60	Sliding ring	
61	Shaft sleeve	
64	Mech. seal stop ring cover	
65	Mech. seal stop half-ring	
66	Mech. seal washer	
67	Pump casing	
68	Sieve	
69	Clamp coupling	
70	Coupling shield with M5 screw	
71	Stud bolt	
72	O-ring	
73	Rotary shaft seal	
74	Mechanical seal	
75	Retaining ring	
76	Parallel pin	DIN 7
77	Suction screw	
78	Hexagon socket head cap screw	DIN 912
79	Serrated lock washer	DIN 6798
80	Hexagon nut	DIN 934
81	Hexagon cap nuts	DIN 917
88	Woodruff key	DIN 6888
89	Distance plate instead of impeller at empty stage	
89	Impeller at full stage number	
Design STH see page 13:		
82	Joining socket STH	
83	Socket head cap screw STH	DIN 912
84	Spring washer STH	DIN 7980
85	O-ring STH	
86	Screw plug STH	DIN 908
87	Sealing ring STH	DIN 7603

10.3 Indications to the spare part order

Spare parts are available from the supplier. Standard commercially available parts are to be purchased in accordance with the model type. The ordering of spare parts should contain the following details:

1. Pumptype

e.g. TH1407A470

2. Pump No.

e.g. 06243914

The date of the construction year is a component of the pumps type number.

3. Voltage. Frequency and Power

Take item 1, 2 and 3 from the nameplate

4. Spare part with item No.

e.g. Impeller item No. 57

11 Repair

11.1 Exchange the rotary mechanical seal: (S)TH11...(S)TH17

- 1) Disconnect the pump from the power supply.
- 2) Loosen the M5 screws and pull out coupling shield (70). Remove clamp coupling (69.1. 69.2) and parallel pin (76).
- 3) Loosen and pull off the hexagon cap nuts (81), the stud bolt (71) and the pump casing (67) from the pump unit. Remove pump unit with pump shaft (52) from the pump body (50).
- 4) Take off rotating axial face seal unit (74.1-74.5) and mech. seal washer (66) from the shaft (52) and clean the shaft. Pay attention to the drilled hole for the parallel pin (76) that it is without any bur. Check the sliding surface for the rotary shaft seal (73) for any damage.
- 5) Remove complete seal (74.6. 74.7) from the pump body (50) and clean the seat.
- 6) Mounting of the new axial face seal:

Ensure that the sliding surfaces of the ring and the rotating axial face seal unit are free from grease and dirt.

Moisten the angle-sleeve (74.7) of the counter ring lightly with rinse water / (water with washing-up liquid) and push the unit into the seat of the pump body (50).

Slide the mech. seal washer (66) first and then the axial face seal (74.1-74.5) onto the pump shaft (52).
- 7) Lubricate lightly the lip of the rotary shaft seal (73) and push it into the pump body (50). Then insert the pump shaft (52) with the pump unit through the rotary shaft seal (73).
- 8) Fit together the coupling clamp (69) with the parallel pin (76) around the shafts, tighten the hexagon socket head cap screws (78) with the serrated lock washer (79) lightly.

Be sure that the key of the motor shaft (4) coincides with the key groove of the coupling clamp (69.1). Press the pump shaft (52) toward the motor and tighten the screws.

The distance between the two shaft ends **must be zero**.

- 9) Lubricate the O-ring seal (72) of the pump body (50), screw and put on the stud bolt (71), the hexagon cap nuts (81) and the pump casing (67).
- 10) Fit the coupling shield (70) into the pump body (50) and tighten the M5 screws.
- 11) Reconnect pump to the power supply.

Check direction of rotation!

Tightening torques for screwed connections

Thread - Ø	M4	M5	M6	M8	M10
Strength classes	4.8	4.8	8.8	8.8	8.8 / 10.0
Tightening torque (Nm)	1 Nm	3 Nm	4.5 Nm 20 Nm Clamp coupling	15 Nm 30 Nm Clamp coupling	30 Nm

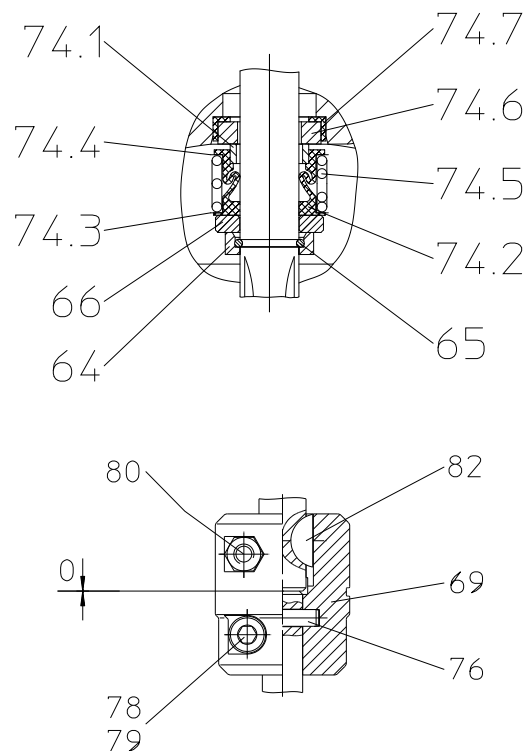

12 Disposal

When disposing of the pump or the packaging materials the local and national regulation for proper disposal must be complied with. Prior to its disposal, the pump must be completely drained and decontaminated if necessary.

13 Declarations of conformity

13.1 UK declaration of conformity



UK declaration of conformity

Manufacturer

Brinkmann Pumpen, K. H. Brinkmann GmbH & Co. KG
Friedrichstraße 2
D-58791 Werdohl
Germany

This declaration of conformity is issued under the sole responsibility of Brinkmann Pumps and belongs to the following product.

Product name

Immersion pumps

Type **TH/STH11 ... 17**

The named product described above complies with the following statutory requirements of United Kingdom:

UK SI 2008 No. 1597	The Supply of Machinery (Safety) Regulations 2008
UK SI 2016 No. 1091	The Electromagnetic Compatibility Regulations 2016
UK SI 2020 No. 1647	The Restriction of the Use of Certain Hazardous Substances in Electrical and Electronic Equipment Regulations 2020

The following exceptions in accordance with table 1, "Table of exempted applications" are claimed: No.12 (6a), No.15 (6b)

The following designated standards and technical specification have been applied:

EN 809:1998+A1:2009+AC:2010	EN ISO 12100:2010	EN 60204-1:2018
EN IEC 61000-3-2 :2019 +A1 :2021	EN 61000-3-3 :2013+A1 :2019 +A2 :2021 +A2 :2021/AC :2022	
EN IEC 61000-6-2 :2019	EN IEC 61000-6-3 :2021	EN IEC 63000 :2018

Additionally the following standard has been applied:

EN 60034-1 :2010/AC :2010

The instructions contained in the operating manual for installation and start up the pump have to be followed.

Brinkmann Pumpen, K. H. Brinkmann GmbH & Co.
KG

Werdohl, 21.07.2025

.....
Dr.-Ing. Dirk Wenderott
Head of Engineering

Dr. H. Abou Dayé
K. H. Brinkmann GmbH & Co. KG
Friedrichstraße 2, D-58791 Werdohl
Representative of documentation

13.2 EC declaration of conformity

DEUTSCH / ENGLISH / FRANÇAIS / ESPAÑOL



EG-Konformitätserklärung

EC declaration of conformity / Déclaration de conformité CE / Declaración de conformidad CE

Hersteller / Manufacturer / Constructeur / Fabricante

Brinkmann Pumpen, K. H. Brinkmann GmbH & Co. KG
Friedrichstraße 2, D-58791 Werdohl

Produktbezeichnung / Product name / Désignation du produit / Designación del producto

Tauchpumpen / Immersion pumps / Pompes plongeantes / Bombas de inmersión

Typ / Type / Tipo TH/STH11 ... 17

Das bezeichnete Produkt stimmt mit den folgenden Richtlinien des Rates zur Angleichung der Rechtsvorschriften der EG-Mitgliedsstaaten überein:

The named product conforms to the following Council Directives on approximation of laws of the EEC Member States:
Le produit sus-mentionné est conforme aux Directives du Conseil concernant le rapprochement des législations des Etats membres CEE:

El producto designado cumple con las Directivas del Consejo relativas a la aproximación de las legislaciones de los Estados Miembros de la CEE:

2006/42/EG	Richtlinie für Maschinen
2006/42/EC	Council Directive for machinery
2006/42/CE	Directive du Conseil pour les machines
2006/42/CE	Directivas del Consejo para máquinas
2014/30/EU	Richtlinie für elektromagnetische Verträglichkeit
2014/30/EU	Council Directive for Electromagnetic compatibility
2014/30/UE	Directive du Conseil pour Compatibilité électromagnétique
2014/30/UE	Directivas del Consejo para Compatibilidad electromagnética

2011/65/EU und 2015/863/EU	RoHS Richtlinien
2011/65/EU and 2015/863/EU	RoHS Directives
2011/65/UE et 2015/863/UE	Directives RoHS
2011/65/UE y 2015/863/UE	RoHS Directivas

Folgende Ausnahmen gem. Anhang III RoHS (2011/65/EU) werden in Anspruch genommen: 6a, 6b.

The following exceptions in accordance with appendix III RoHS (2011/65/ EU) are claimed: 6a, 6b.

Les exceptions suivantes selon l'annexe III RoHS (2011 / 65 / UE) sont revendiquées : 6a, 6b.

Las siguientes excepciones conforme al apéndice III RoHS (2011/65 / UE) son requeridas: 6a, 6b.

Hinsichtlich der elektrischen Gefahren wurden gemäß Anhang I Nr. 1.5.1 der Maschinenrichtlinie 2006/42/EG die Schutzziele der Niederspannungsrichtlinie 2014/35/EU eingehalten.

With respect to potential electrical hazards as stated in appendix I No. 1.5.1 of the machine guide lines 2006/42/EC all safety protection goals are met according to the low voltage guide lines 2014/35/EU.

Conformément à l'annexe I N° 1.5.1 de la Directive "Machines" (2006/42/CE) les objectifs de sécurité relatifs au matériel électrique de la Directive "Basse Tension" 2014/35/UE ont été respectés.

Con respecto al potencial peligro eléctrico como se indica en el apéndice I No. 1.5.1 del manual de la máquina 2006/42/CE, todos los medios de protección de seguridad se encuentran según la guía de bajo voltaje 2014/35/UE.

Die Übereinstimmung mit den Vorschriften dieser Richtlinien wird nachgewiesen durch die vollständige Einhaltung folgender Normen:

Conformity with the requirements of this Directives is testified by complete adherence to the following standards:

La conformité aux prescriptions de ces Directives est démontrée par la conformité intégrale avec les normes suivantes:

La conformidad con las prescripciones de estas directivas queda justificada por haber cumplido totalmente las siguientes normas:

Harmonisierte Europ. Normen / Harmonised Europ. Standards / Normes europ. harmonisées / Normas europ. Armonizadas

EN 809 :1998+A1 :2009+AC :2010 EN ISO 12100 :2010 EN 60204-1 :2018 EN IEC 61000-3-2 :2019 +A1 :2021
EN 61000-3-3 :2013+A1 :2019 +A2 :2021 +A2 :2021/ZAC :2022 EN IEC 61000-6-2 :2019 EN IEC 61000-6-3 :2021
EN IEC 63000 :2018

Nationale Normen / National Standards / Normes nationales / Normas nacionales : **EN 60034-1 :2010/AC :2010**

Die Hinweise in der Betriebsanleitung für den Einbau und die Inbetriebnahme der Pumpe sind zu beachten.

The instructions contained in the operating manual for installation and start up the pump have to be followed.

Les indications d'installation / montage et de mise en service de la pompe prévues dans l'instruction d'emploi doivent être suivies.

Tenga en cuenta las instrucciones en el manual para la instalación y puesta en marcha de la bomba.

Brinkmann Pumpen, K. H. Brinkmann GmbH & Co. KG

Werdohl, 21.07.2025

Dr.-Ing. Dirk Wenderott
Head of Engineering

Dr. H. Abou Dayé

K. H. Brinkmann GmbH & Co. KG
Friedrichstraße 2, D-58791 Werdohl

Dokumentationsbevollmächtigter / Representative of
documentation/ Mandataire de documentation /
Mandatario de documentación