

A-2-B switch, type 0910

For limiting the hoist height

BROSA A-2-B switches prevent the hook block or load hook to be pulled against the boom head. During the operation a suspended weight keeps the A-2-B switch contact closed. The uplifting of the suspended weight will open the contact only when the hook block has reached the maximum admissible position. The A-2-B switch is characterised by its corrosion-resistant light metal housing and the completely casted electronic functional parts. Two resistors are installed to control the feed lines. An optional suitable counterweight is available.

Applications

- Cranes
- Lifting technology

Features

- Easy assembly
- Corrosion-resistant housing
- Positively driven end switch

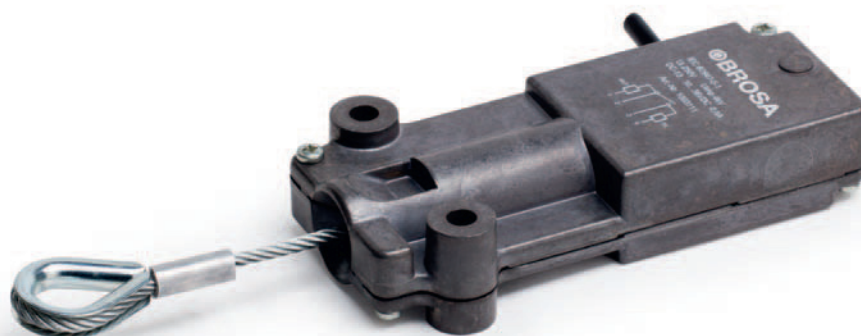

A-2-B switch, type 0910

Technical data

Material	Light metal die cast, anodised
Dimensions	60 x 155 x 32 mm
Weight	0.73 kg
Switching system	Slow action, 1 contact, positively driven
Protection class	In case of a suspended assembly IP 54 Protection class switch insert IP 67
Contact travel	7 mm
Spring pre-load	40.4 ± 3.6 N
After 7 mm spring travel	48.5 ± 3.8 N
Operating temperature	-40 to +80 °C
Contact load capacity	24 VDC 1.0 A 36 VDC 0.8 A
Mechanical life	10 ⁶ switching cycles
Cable	Control line, shielded, 4 x 1 mm ²
Cable length	3 m

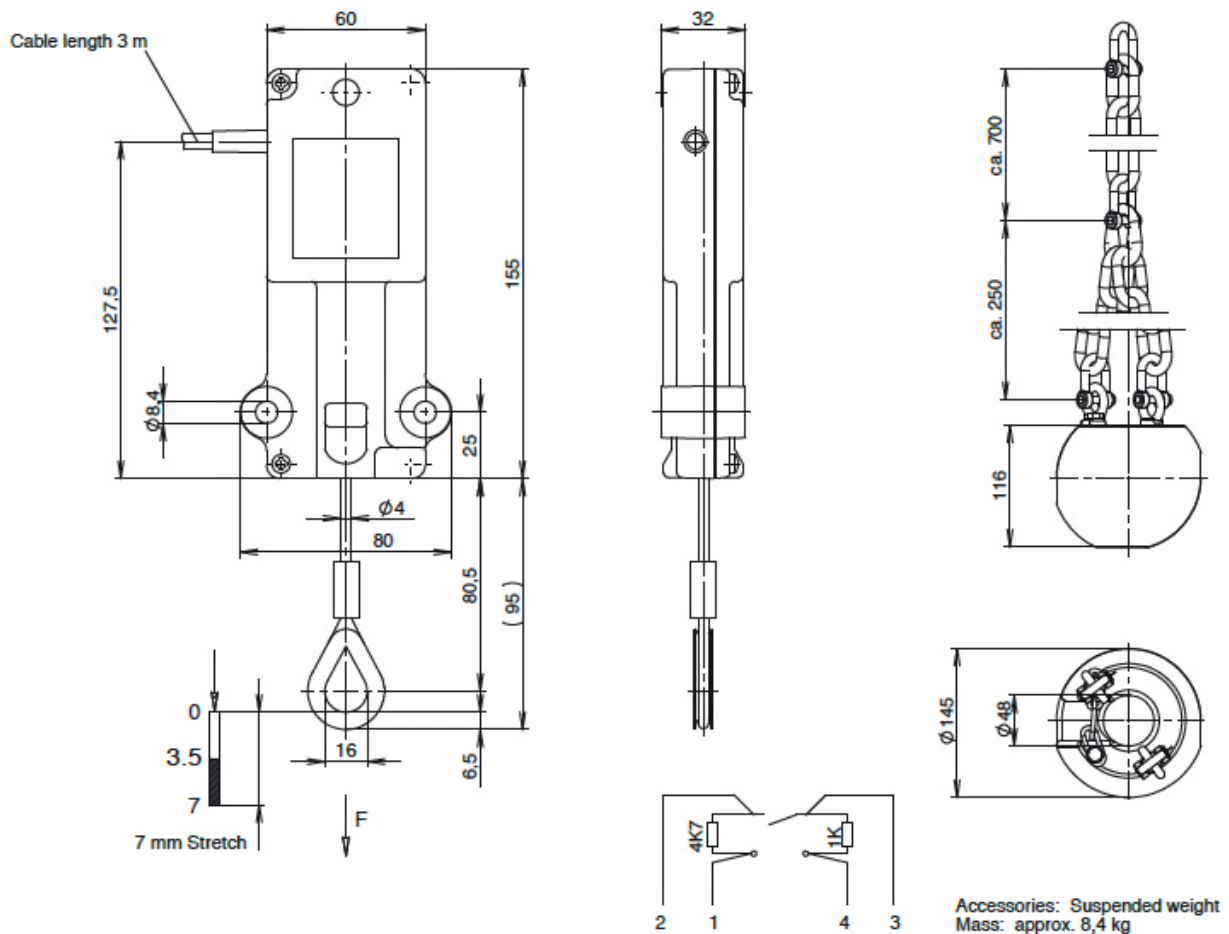

ISO 9001:2008
ISO 14001:2004



94/9/EG