



Sample gas pumps P1.1, P1.1E, P1.2, P1.2E

Gas analysis is key for safe and efficient system operation in the chemical industry, petrochemistry or biochemistry. Many of the analysis processes used in these fields require sample gas extraction and conditioning.

Sample gas pumps convey the sample gas from the sampling point to the conditioning system. The main item in these pumps designed specifically for the application is the PTFE single-piece bellows. Combined with the pump head, also single-piece, this solution provides high resistance against particularly aggressive sample gas. Turning the pump head allows gas with condensate to be conveyed without a problem.

Easy to replace valves

Single-piece bellows

Conveys sample gas with condensate

Proven pump technology

Attractive price

Requires little space

Housing version IP20

Optionally with built-in bypass valve

FM C-US approval (general purpose) optional

Used in **DNV type-tested** conditioning unit

Can be used in a system to maintain **the IMO MARPOL MEPC.259(68)**

Special design for use in high vibration environments



Technical data

Technical data P1.1/P1.1E

Nominal voltage/Power input:	230 V 50 Hz, 0.48 A 115 V 60 Hz, 0.84 A 12 V DC, 1.55 A 24 V DC, 0.8 A
Protection class OEM/housing & 12 V/24 V:	IP 00/IP 20
Mechanical load	Tested based on DNV CG-0339 vibration class A (0.7g) 2 Hz-13.2 Hz Amplitude ± 1.0 mm 13.2 Hz -100 Hz 0.7g acceleration
Weight (without accessories):	approx. 2.9 lb (12 V/24 V approx. 1.8 lb)
Media temperature:	158 °F
Ambient temperature:	32 °F to 122 °F
Nominal output:	280 l/h (4.7 lpm)
Materials in contact with media vary by configuration:	PTFE, PVDF, 1.4571, 1.4401, Viton

Technical Data P1.2/P1.2E

Nominal voltage/Power input:	230 V 50 Hz, 0.48 A 115 V 60 Hz, 0.84 A
Protection class OEM/housing:	IP 00/IP 20
Weight (without accessories):	approx. 2.9 lb
Media temperature:	see temperature classes
Ambient temperature:	32 °F to 122 °F
Nominal output:	280 l/h (4.7 lpm)
Materials in contact with media vary by configuration:	PTFE, PVDF, 1.4571, 1.4401, Viton

The gas lines are connected via screw-in connections (G1/4 thread). The respective screw-in connections as well as mounting bracket and vibration absorber are sold separately.

Temperature classes

Pump models P1.2/P1.2E

		Medium temperature
no flammable gasses in the gas circuit		158 °F
Flammable gasses in the gas circuit above the LEL	T3	158 °F
	T4	122 °F

Marking P1.2/P1.2E

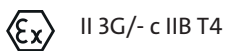

Note: This device is not suitable for use in explosive areas!

Feed curve

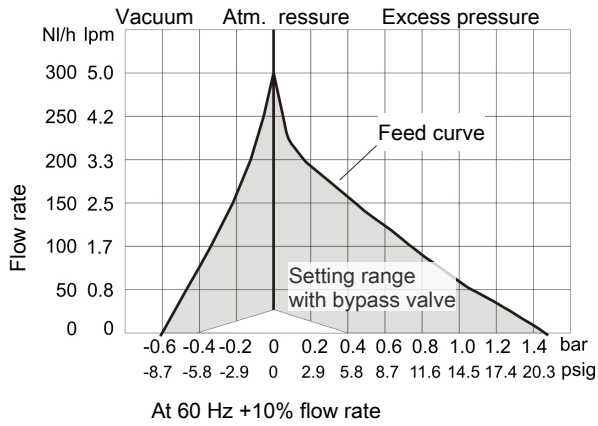

Dimensions P1.1 / P1.2 pump (115 V or 230 V)

The P1.1/P1.2 sample gas pump is connected to electricity via blade receptacles.

without accessories:

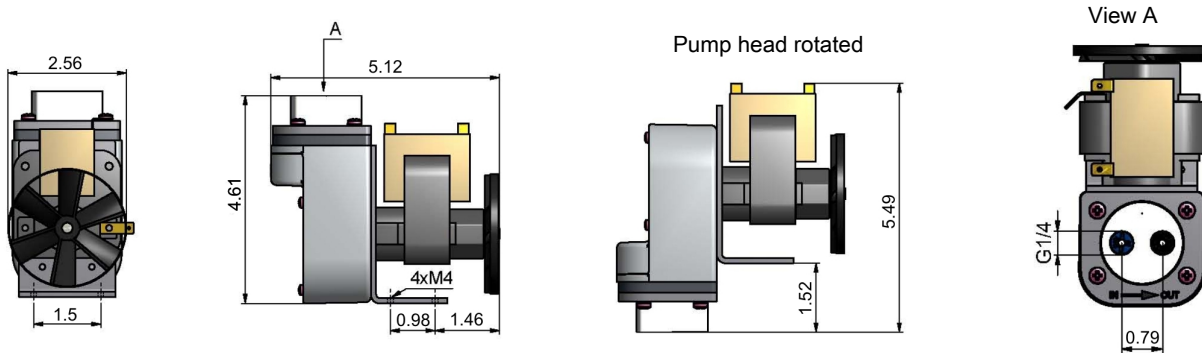

with accessories:

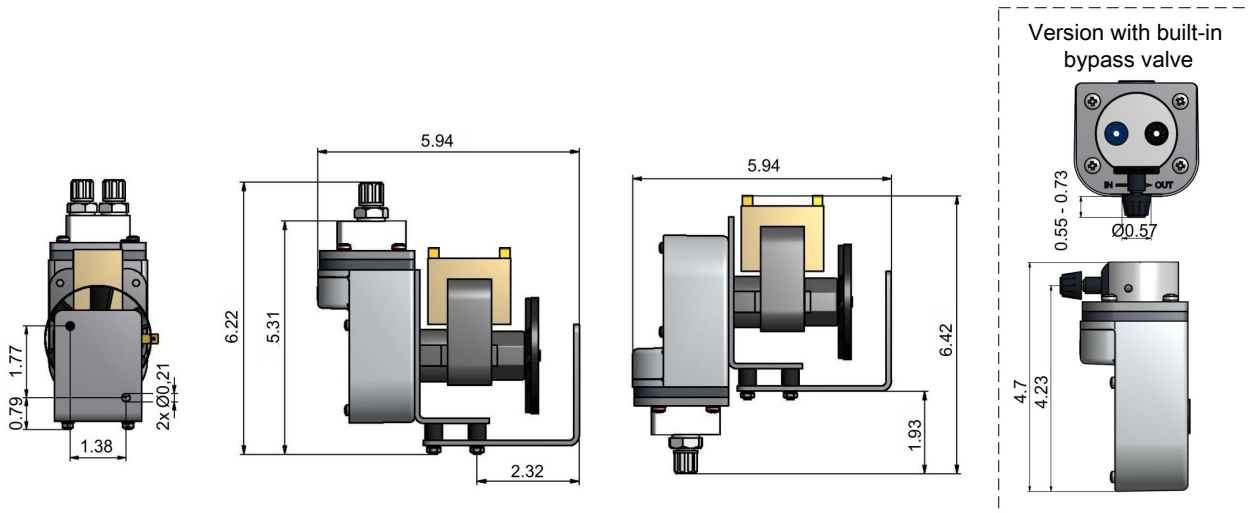

Dimensions P1.1 (12 V DC or 24 V DC)

The P1.1 (24 V DC) sample gas pump may be connected by standard 3 m (9.8 ft) connecting cable.

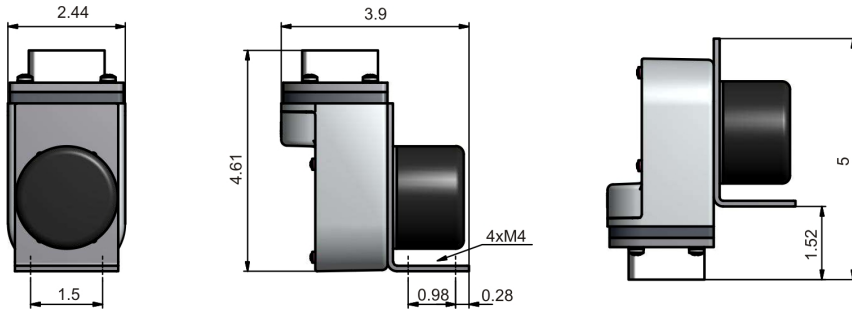

Dimensions P1.1E / P1.2E pump (all voltages)

The P1.1E/P1.2E sample gas pump may be connected by standard 3 m (9.8 ft) connecting cable.

without accessories:

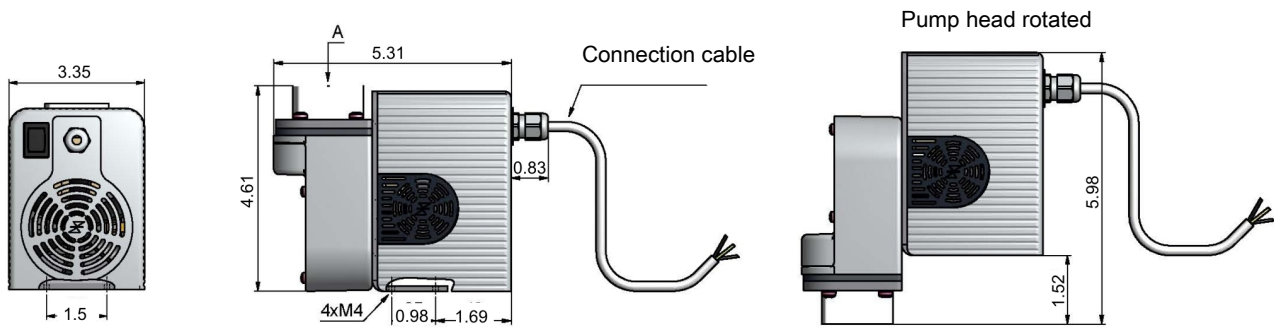

with accessories:

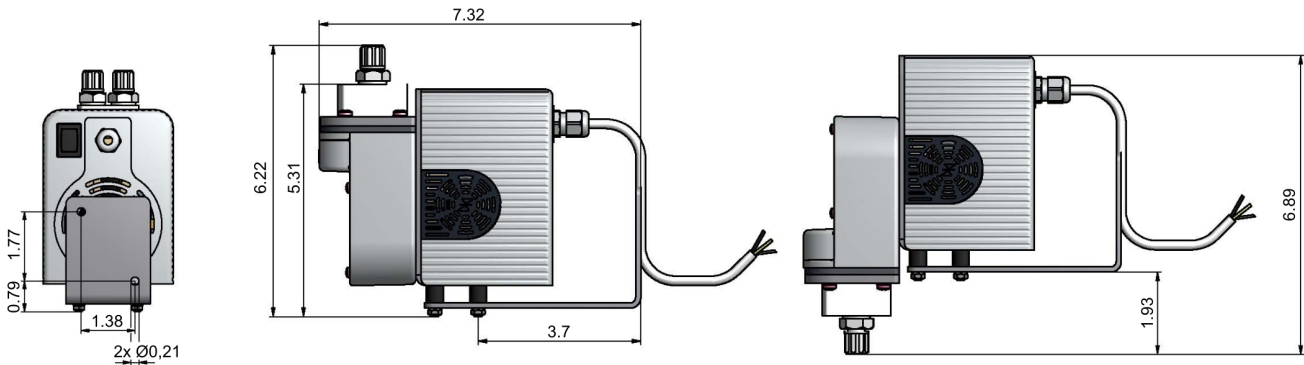

Ordering instructions P1.1 / P1.1E

42	28	x	x	x	1	x	x	x	00	xx	Product feature
											Motor voltage
											1 230 V 50 Hz 0.48 A
											2 115 V 60 Hz 0.84 A
											3 12 V DC 1.55 A (on request)
											4 24 V DC 0.8 A
											Pump head position
											1 Normal position vertical
											2 turned by 180°
											Pump head material
											1 PTFE
											2 VA (1.4571)
											3 PVDF with bypass valve
											4 PVDF
											Valve material
											1 up to 158 °F; PTFE/PVDF
											Screw-in connections/pipe fittings
											0 without
											1 PVDF DN 4/6 *
											2 PVDF 1/4"-1/6" *
											3 PVDF 1/4"-1/8" *
											5 VA (1.4401) 6 mm **
											6 VA (1.4401) 1/4" **
											Mounting accessories
											0 without
											1 Mounting bracket and set of vibration dampers
											2 set of vibration dampers only
											Housing
											0 without
											1 Housing incl. 3 m (9.8 ft) connection cable
											2 Housing with on/off switch incl. 3 m (9.8 ft) connection cable ***
											Options
											00 without
											Approval
											-- without
											FM FM-Approval

* PTFE or PVDF pump body only

** VA pump body only

*** not possible with 12V/24V and/or FM approval

Ordering instructions P1.2 / P1.2E

42	29	x	x	x	1	x	x	x	00	Product characteristic
										Motor voltage
										1 230 V 50 Hz 0.48 A
										2 115 V 60 Hz 0.84 A
										Pump head position
										1 Normal position vertical
										2 turned by 180°
										Pump head material
										1 PTFE
										2 VA (1.4571)
										3 PVDF with bypass valve
										4 PVDF
										Valve material
										1 up to 158 °F; PTFE/PVDF
										Screw-in connections/pipe fittings
										0 without
										1 PVDF DN 4/6 *
										2 PVDF 1/4"-1/6" *
										3 PVDF 1/4"-1/8" *
										5 VA (1.4401) 6 mm **
										6 VA (1.4401) 1/4" **
										Mounting accessories
										0 without
										1 Mounting bracket and set of vibration dampers
										2 set of vibration dampers only
										Housing
										0 without
										1 Housing incl. 3 m (9.8 ft) connection cable
										2 Housing with on/off switch incl. 3 m (9.8 ft) connection cable

* PTFE or PVDF pump body only

** VA pump body only