

J125

Service Regulator

Inlet Pressure up to 8.6 bar

Nominal Diameter 1½" & 2"

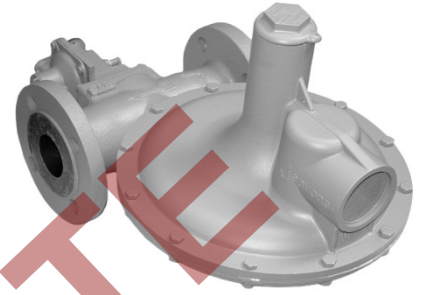

Applications

- Industrial
- Commercial
- Residential

Brief information

Operation: The J125 series provides a full range of regulators for service applications where accurate pressure control is required. The units are ideal for industrial pressure reducing, metering stations and for district distribution. A monitor version of the J125 is also available. The regulators are designed to maintain high accuracy and efficiency over the inlet pressures up to 8.6 bar (125 PSIG). Available with screwed connections, sizes 1½" and 2", and 50mm flanged connections.

Several valve orifices are available to cover the full inlet pressure range, together with a comprehensive number of outlet pressure springs.

The unit has been designed for ease of installation and servicing in confined areas. The diaphragm case can be fully rotated and, during inspection and servicing, the case can be removed without disturbing the pipework.

The J125 can be fitted with a full or limited capacity relief valve. In addition, the regulator can be supplied with the Jeavons Universal Safety Shut-off Assembly (USSA). This provides over pressure and/or under pressure protection with immediate shut-off at the regulator inlet. It uses well proven principles to give exceptional consistency of operation and an unrivalled insensitivity to nuisance tripping.

Application: All units are suitable for operation on natural, liquefied petroleum and manufactured gases. Various versions of this regulator comply with the requirements of BGC/PS/E26 & IGE/TD/10. The USSA unit is designed to meet the requirements of the standards BS EN 14382, BGES/V9 & DIN3381.

Technical Data:

Maximum inlet pressure:	8.6 Bar (125 psig)
Maximum outlet Pressure:	350mbar (5 psig)
OPSS range:	18 - 500mbar (7.5"wg – 7 psig)
UPSS range:	8 - 150mbar (3 – 60 "wg)

Approval: The 1½" and 2" J125 have been approved to Modulus B + D of the PED 97/23/EC by BSI (Notified Body No. 0086). It is classified as Category IV equipment and a pressure accessory.

Servicing: The J125 has been designed for ease of access, inspection and servicing of all internal components. A standard soft spares kit is available for all sizes.

J125-S1 & S3	reference number SK2529-01
J125-S2	reference number SK2529-02
J125-S4, S6 & S8	reference number SK2529-03
J125-S5, S7, S9, S10, S11 & S12	reference number SK2529-04

Main features

- Sizes 1½", 2" & 50mm (for ¾" & 1" see separate leaflet)
- Temperature range -20°C to +60°C
- Threaded connections to BS EN 10226 (ISO 7) or NPT. Flanged to BS EN 1092-2 NP16 or ANSI (other connection standards may be available upon request)
- Internal impulse
- Spring loaded
- Excellent outlet pressure control

Options

- Full or limited relief valve
- Over pressure slam shut
- Under pressure slam shut
- Pressure test nipple

J125: Service Regulator

Schematic Installation

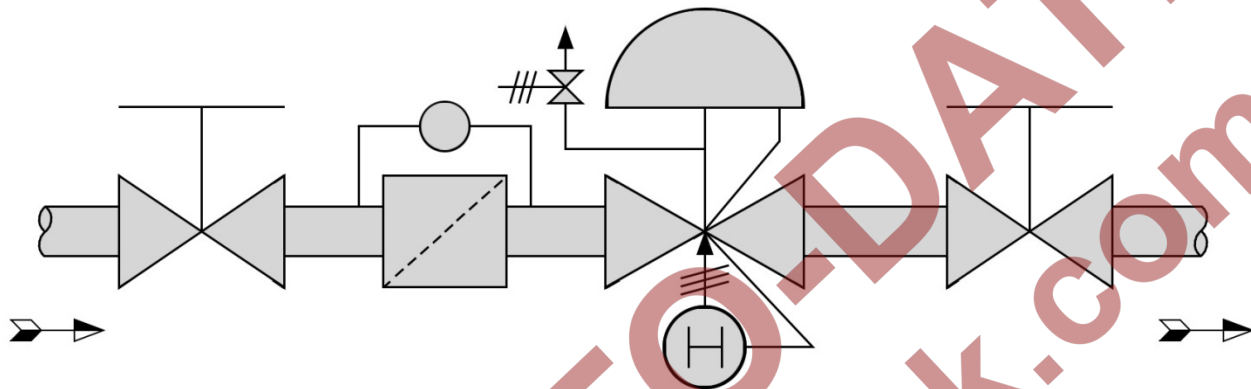

Regulator Springs

mbar	"wg	Part Number	Colour Code
8.8 - 15	3.5 - 6	J12509-091	Red
14 - 20	5.5 - 8	J12509-092	Orange
21 - 35	8.5 - 14	J12509-093	Yellow
36 - 70	14.5 - 28	J12509-094	Green
69 - 138	1 - 2 PSI	J12509-095	Royal Blue
104 - 173	1.5 - 2.5 PSI	J12509-096	Brown / Royal Blue
138 - 207	2 - 3 PSI	J12509-097	Brown / Green
207 - 350	3 - 5 PSI	J12509-098	Black / Green

OPSS Springs

mbar	"wg	Part Number	Colour Code
18 - 60	7.5 - 24	J12506-281	Black
50 - 80	20 - 32	J12506-282	Orange
60 - 110	24 - 44	J12506-283	Red
100 - 210	40 - 84	J12506-284	Dark Green
200 - 350	3 - 5 PSI	J12506-287	Yellow
280 - 500	4 - 7 PSI	J12506-288	White

UPSS Springs

mbar	"wg	Part Number	Colour Code
8 - 16	3 - 6	J12506-285	Light Blue
16 - 60	6 - 24	J12506-286	Brown
60 - 150	24 - 60	J12506-289	Purple

J125: Service Regulator

J125 Versions

The following table indicates the code numbers of the various J125 versions available.

TYPE	Full Capacity Relief (FR)	Limited Capacity Relief (LR)	Over Pressure Slam Shut (OPSS)	Under Pressure Slam Shut (UPSS)	Safety Diaphragm	Unit Weight (Kg)	
						Screwed	Flanged
J125-S1						10.4	16.5
J125-S2	*					10.4	16.5
J125-S3		*				10.4	16.5
J125-S4	*		*			10.9	17.0
J125-S5		*	*			10.9	17.0
J125-S6	*			*		10.9	17.0
J125-S7		*		*		10.9	17.0
J125-S8	*		*	*		10.9	17.0
J125-S9		*	*	*		10.9	17.0
J125-S10			*			10.9	17.0
J125-S11				*		10.9	17.0
J125-S12			*	*		10.9	17.0

Dimensions

J125 S1/S2/S3 Screwed

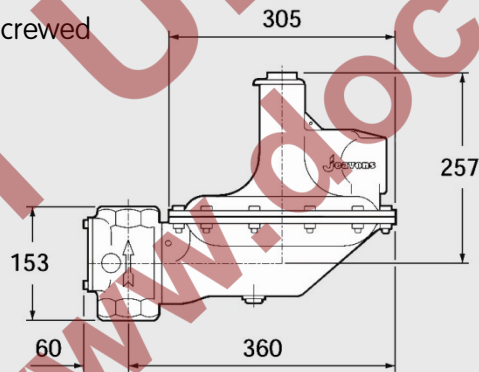

J125 S1/S2/S3 Flanged

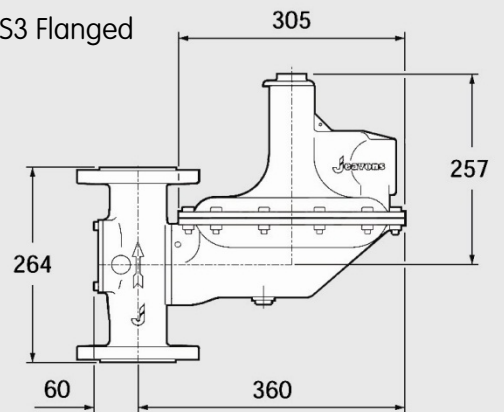

J125 S4 – S12 Screwed

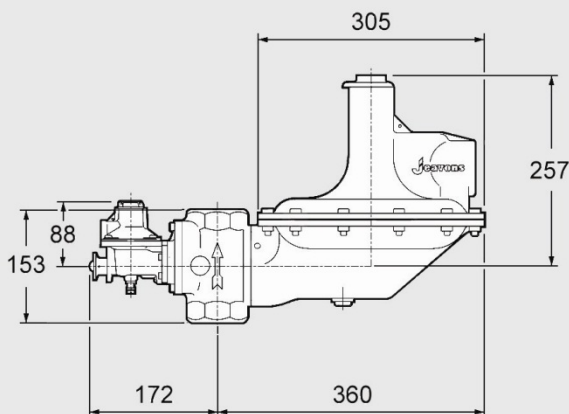

J125 S4 – S14 Flanged

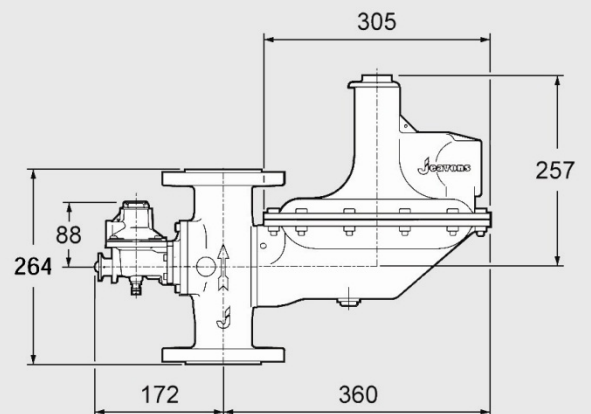

J125: Service Regulator – 1½" Size

Regulating Capacities

All capacities in SCM_H 0.64 s.g. Droop = 20%

6.35mm (¼") Orifice

Spring Range (mbar)	8.8 - 15	14 - 20	21 - 35	36 - 70	69 - 138	104 - 173	138 - 207	207 - 350
Setting Pressure (mbar)	15	17.5	35	60	100	150	200	345
Inlet Pressure (mbar)								
350	34	35	32	30	30	26	22	-
689	50	51	49	50	47	38	45	35
1000	60	60	59	58	58	56	55	55
1500	76	76	75	72	72	75	70	75
2000	91	92	91	90	85	95	90	95
3000	121	121	121	126	115	120	110	115
4000	145	150	155	155	145	155	140	150
5000	160	165	175	175	170	180	170	175
6000	180	185	180	185	180	190	180	185
8000	230	230	240	230	230	240	215	225

9.5mm (⅜") Orifice

69	20	20	-	-	-	-	-	-
138	34	36	28	-	-	-	-	-
200	40	42	38	38	-	-	-	-
350	53	55	50	53	44	42	41	-
689	76	78	72	80	68	70	73	58
1000	87	92	88	99	86	91	95	80
1500	104	108	109	123	111	116	122	114
2000	119	124	126	152	130	146	151	140
3000	140	144	157	186	178	190	196	190
4000	160	164	178	218	210	230	242	236
5000	180	185	207	244	230	250	264	258
7000	-	-	-	282	284	294	311	314

12.7mm (½") Orifice

50	27	29	20	-	-	-	-	-
69	33	35	27	-	-	-	-	-
138	49	52	45	48	-	-	-	-
200	57	61	55	61	42	-	-	-
350	72	75	74	83	63	64	68	-
689	93	97	102	115	95	105	114	90
1000	107	111	121	135	118	131	149	125
1500	120	124	142	166	152	167	182	174
2000	132	137	157	182	180	198	222	211
3000	152	157	182	212	219	246	282	274
4000	174	178	208	234	251	292	322	326
5000	-	-	224	249	274	314	344	349

15.9mm (⅝") Orifice

50	32	33	-	-	-	-	-	-
69	38	40	32	-	-	-	-	-
138	53	56	49	67	-	-	-	-
200	60	64	58	75	54	-	-	-
350	72	76	75	99	77	77	78	-
689	89	93	96	129	115	120	128	104
1000	100	105	115	149	137	146	167	141
1500	113	120	132	170	170	184	207	195
2000	123	128	148	190	196	211	239	225
3000	142	149	173	210	233	254	287	288
4000	-	-	194	230	259	287	324	338
5000	-	-	-	-	270	304	344	360

J125: Service Regulator – 1½" Size

Regulating Capacities

All capacities in SCMH 0.64 s.g. Droop = 20%

19.1mm (¾") Orifice

Spring Range (mbar)	8.8 - 15	14 - 20	21 - 35	36 - 70	69 - 138	104 - 173	138 - 207	207 - 350
Setting Pressure (mbar)	15	17.5	35	60	100	150	200	345
Inlet Pressure (mbar)								
50	40	43	-	-	-	-	-	-
69	48	51	37	-	-	-	-	-
138	64	68	57	71	-	-	-	-
200	72	77	70	86	58	-	-	-
350	90	93	90	112	87	88	96	-
689	113	115	120	150	123	137	154	124
1000	127	129	138	167	154	171	188	168
1500	150	154	163	193	181	202	238	220
2000	170	174	183	212	210	240	274	266
3000	194	196	213	244	260	283	340	335
4000	-	-	242	273	285	322	397	416
5000	-	-	-	281	297	336	414	434

22.2mm (⅞") Orifice

50	41	45	-	-	-	-	-	-
69	51	56	-	-	-	-	-	-
138	70	76	67	-	-	-	-	-
200	79	86	85	98	-	-	-	-
350	95	102	109	131	100	102	109	-
689	123	130	145	179	150	167	193	162
1000	146	154	172	198	190	206	226	210
1500	182	188	203	236	234	257	288	279
2000	-	-	231	266	274	300	344	340
2500	-	-	-	289	305	337	386	392
3000	-	-	-	-	332	366	433	440

25.4mm (1") Orifice

50	47	51	40	-	-	-	-	-
69	54	57	49	-	-	-	-	-
138	71	76	73	-	-	-	-	-
200	77	84	84	105	70	73	-	-
350	94	99	108	131	105	115	120	130
689	121	126	136	167	150	179	198	163
1000	135	138	158	190	180	210	230	207
1500	-	-	189	215	215	246	285	270
2000	-	-	-	235	245	278	319	320

31.8mm (1¼") Orifice

50	43	45	48	-	-	-	-	-
69	50	53	56	-	-	-	-	-
138	66	73	82	96	-	-	-	-
200	78	82	92	117	83	-	-	-
350	94	97	117	143	122	141	144	-
689	-	-	149	178	174	208	210	195
1000	-	-	171	201	210	231	247	239
1500	-	-	-	-	234	269	296	306
2000	-	-	-	-	-	304	333	360

J125: Service Regulator – 2" Size

Regulating Capacities

All capacities in SCMH 0.64 s.g. Droop = 20%

6.35mm (1/4") Orifice

Spring Range (mbar)	8.8 - 15	14 - 20	21 - 35	36 - 70	69 - 138	104 - 173	138 - 207	207 - 350
Setting Pressure (mbar)	15	17.5	35	60	100	150	200	345
Inlet Pressure (mbar)								
350	35	35	35	37	25	26	22	-
689	45	50	50	46	40	38	45	35
1000	60	60	60	60	55	56	55	55
1500	75	80	70	80	75	75	70	75
2000	85	90	95	90	95	95	90	95
3000	125	125	120	120	120	120	110	115
4000	155	150	155	155	145	155	140	150
5000	160	165	175	175	170	180	170	175
6000	180	185	180	185	180	190	180	185
8000	230	230	240	230	230	240	215	225

9.5mm (3/8") Orifice

69	30	30	25	-	-	-	-	-
138	40	40	35	-	-	-	-	-
200	50	50	45	45	-	-	-	-
350	70	70	60	65	50	55	55	-
689	100	100	90	100	80	90	95	75
1000	125	125	120	125	105	115	125	100
1500	155	155	155	155	135	150	160	135
2000	185	190	190	190	165	190	190	170
3000	245	250	250	255	230	250	255	230
4000	310	315	315	315	300	315	315	300
5000	330	335	340	345	335	335	340	335
7000	-	-	-	405	400	405	415	410

12.7mm (1/2") Orifice

50	25	30	25	-	-	-	-	-
69	30	35	30	-	-	-	-	-
138	50	55	45	50	-	-	-	-
200	70	75	60	65	40	40	-	-
350	100	110	85	100	85	70	80	-
689	150	160	130	145	105	115	135	90
1000	190	200	165	190	135	150	180	130
1500	245	255	225	250	180	205	240	180
2000	295	305	275	305	225	255	300	225
3000	380	410	390	430	315	355	420	315
4000	430	460	515	540	440	480	530	435
5000	-	-	580	580	540	550	580	535

15.9mm (5/8") Orifice

50	35	38	-	-	-	-	-	-
69	45	48	30	-	-	-	-	-
138	75	80	55	-	-	-	-	-
200	90	95	65	85	50	-	-	-
350	130	135	95	120	70	80	80	-
689	205	210	150	190	115	135	135	115
1000	260	265	205	240	145	185	185	165
1500	335	345	285	320	195	245	255	230
2000	380	400	360	400	255	315	320	295
3000	445	470	525	555	370	455	465	420
4000	-	-	670	705	520	600	605	545
5000	-	-	-	-	-	700	700	640

J125: Service Regulator – 2" Size

Regulating Capacities

All capacities in SCMH 0.64 s.g. Droop = 20%

19.1mm (¾") Orifice

Spring Range (mbar)	8.8 - 15	14 - 20	21 - 35	36 - 70	69 - 138	104 - 173	138 - 207	207 - 350
Setting Pressure (mbar)	15	17.5	35	60	100	150	200	345
Inlet Pressure (mbar)								
50	35	45	-	-	-	-	-	-
69	45	60	45	-	-	-	-	-
138	70	85	75	90	-	-	-	-
200	90	110	100	120	65	-	-	-
350	130	145	135	165	105	130	135	-
689	190	205	200	250	155	205	220	170
1000	235	250	250	300	210	265	290	235
1500	320	330	330	390	275	355	400	325
2000	370	395	420	485	350	455	500	415
3000	465	490	565	600	515	610	655	590
4000	-	-	600	655	615	690	760	760
5000	-	-	-	670	625	700	785	785

22.2mm (⅞") Orifice

50	40	45	-	-	-	-	-	-
69	45	55	-	-	-	-	-	-
138	70	85	80	-	-	-	-	-
200	95	110	100	125	-	-	-	-
350	130	145	140	170	105	120	125	-
689	195	205	205	240	160	190	215	165
1000	240	250	250	295	210	250	285	225
1500	320	330	330	390	290	335	375	310
2000	-	-	420	490	360	430	485	390
2500	-	-	-	560	440	520	580	475
3000	-	-	-	-	540	605	645	545

25.4mm (1") Orifice

50	50	45	40	-	-	-	-	-
69	65	58	48	-	-	-	-	-
138	100	95	75	-	-	-	-	-
200	135	125	100	140	75	90	-	-
350	175	168	135	180	120	140	80	-
689	265	260	230	300	190	230	150	170
1000	330	335	305	360	250	300	210	245
1500	-	-	371	416	330	330	300	360
2000	-	-	-	-	420	510	375	460

31.8mm (1¼") Orifice

50	65	60	50	-	-	-	-	-
69	80	80	60	-	-	-	-	-
138	130	125	105	-	-	-	-	-
200	165	165	135	180	110	-	-	-
350	220	220	190	245	150	180	160	-
689	-	-	290	365	240	280	290	215
1000	-	-	380	450	325	345	390	315
1500	-	-	-	-	460	490	520	465
2000	-	-	-	-	-	600	630	570

J125: Service Regulator

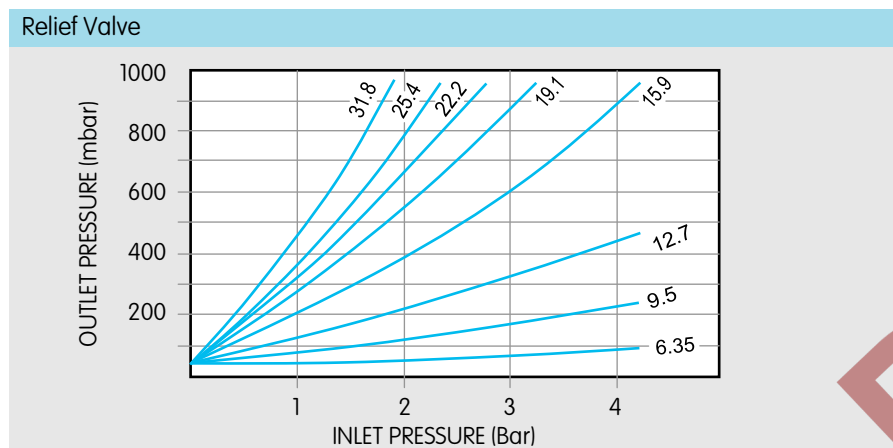

The data represented in the graph left shows the rise in outlet pressure above the set point against change in inlet pressure at a full fault situation.

Orifice Sizes

mm	ins	Maximum Inlet Pressure
6.35	1/4"	8.6 Bar (125 PSIG)
9.5	3/8"	6.8 bar (100 PSIG)
12.7	1/2"	5.5 Bar (80 PSIG)
15.9	5/8"	5.0 Bar (73 PSIG)
19.1	3/4"	4.5 Bar (65 PSIG)
22.2	7/8"	2.7 Bar (39 PSIG)
25.4	1"	2.0 Bar (29 PSIG)
31.8	1 1/4"	1.5 Bar (22 PSIG)

For optimum regulator performance, the largest permissible orifice size should be selected from this table. For the optimum relief valve performance, the smallest orifice should be selected.

Material Specifications

A summary of the material specification for the J125 is given for reference. All material has been selected to provide maximum durability and reliability in service.

Components	Specification
Regulator Body	Nodular Iron BS EN 1563 400/15
Regulator Valve Disc and "O" rings, USSA Diaphragm	Nitrile Synthetic Rubber (Buna)
USSA Valve Disc and "O" rings	Nitrile Synthetic Rubber (DIN 3535 Part 3)
Regulator Valve, Valve Seat and USSA Valve	Aluminium Alloy BS EN 755
Regulator Case and Cover, Relief Valve, Spring Holder, Top Cap, Adaptor Plate, USSA Body and Cover	Aluminium Alloy BS EN 1706
Regulator and USSA Valve Spindle	Stainless Steel BS EN 10088-3
Regulator Diaphragm	Reinforced Synthetic Rubber
USSA Internals	Acetal Resin
Lever Arm, Regulator Diaphragm Plate, Vent Valve Plates, Clamping Plate and Spring Guide	Mild Steel, Zinc Plated and Passivated
Springs	Carbon Steel, Zinc Plated and Passivated
Relief Valve Adjusting Nut	Brass BS EN 12164

Quality:

Elster Jeavons is committed to a programme of continuous quality enhancement. All equipment designed and manufactured by the Elster-Instromet group benefits from the group's quality assurance standards which are approved to EN ISO 9001:2008.

Your contacts



United Kingdom
 Elster Metering Ltd.
 Paton Drive, Tollgate Business Park,
 Beaconside, Stafford, Staffs. ST16 3EF
 T +44 1785 275200
 F +44 1785 275305
 www.elster-instromet.com
 stafford.enquiries@elster.com

Germany
 Elster GmbH
 Steinern Str. 19 - 21
 55252 Mainz-Kastel
 T +49 6134 605 0
 F +49 6134 605 223
 www.elster-instromet.com
 info@elster-instromet.com

USA
 Elster American Meter
 2221 Industrial Road
 Nebraska City, NE 68410-6889
 T +1 402 873 8200
 F +1 402 873 7616
 www.elster-meterservices.com

J1252EN06
 A04.08.2015

Copyright 2015 Elster GmbH
 All rights reserved
 Subject to change without prior notice