

590+ Series DC Digital Converter

Product Manual

HA466461U002 Issue 1

Compatible with Version 5.x Software

© Copyright Eurotherm Drives Limited 2001

All rights strictly reserved. No part of this document may be stored in a retrieval system, or transmitted in any form or by any means to persons not employed by a Eurotherm group company without written permission from Eurotherm Drives Ltd.

Although every effort has been taken to ensure the accuracy of this document it may be necessary, without notice, to make amendments or correct omissions. Eurotherm Drives cannot accept responsibility for damage, injury, or expenses resulting therefrom.

WARRANTY

Eurotherm Drives warrants the goods against defects in design, materials and workmanship for the period of 12 months from the date of delivery on the terms detailed in Eurotherm Drives Standard Conditions of Sale IA058393C.

Eurotherm Drives reserves the right to change the content and product specification without notice.

Safety Information



Requirements

IMPORTANT: Please read this information BEFORE installing the equipment.

Intended Users

This manual is to be made available to all persons who are required to install, configure or service equipment described herein, or any other associated operation.

The information given is intended to highlight safety issues, and to enable the user to obtain maximum benefit from the equipment.

Complete the following table for future reference detailing how the unit is to be installed and used.

INSTALLATION DETAILS	
Serial Number <i>(see product label)</i>	
Where installed <i>(for your own information)</i>	
Unit used as a: <i>(refer to Certification for the Converter)</i>	<input type="checkbox"/> Component <input type="checkbox"/> Relevant Apparatus
Unit fitted:	<input type="checkbox"/> Wall-mounted <input checked="" type="checkbox"/> Enclosure

Application Area

The equipment described is intended for industrial (non consumer) motor speed control utilising dc shunt machines.

Personnel

Installation, operation and maintenance of the equipment should be carried out by qualified personnel. A qualified person is someone who is technically competent and familiar with all safety information and established safety practices; with the installation process, operation and maintenance of this equipment; and with all the hazards involved.

Safety Information



Hazards

WARNING!

This equipment can endanger life through rotating machinery and high voltages. Failure to observe the following will constitute an ELECTRICAL SHOCK HAZARD. This is a product of the restricted sales distribution class according to IEC 61800-3. In a domestic environment this product may cause radio interference in which case the user may be required to take adequate measures. This product is designated as "professional equipment" as defined in EN61000-3-2. Permission of the supply authority shall be obtained before connection to the low voltage supply.

- The equipment must be **permanently earthed** due to the high earth leakage current.
- The drive motor must be connected to an appropriate safety earth.
- Before working on the equipment, ensure isolation of the mains supply from terminals L1, L2 and L3.
- Never perform high voltage resistance checks on the wiring without first disconnecting the drive from the circuit being tested.
- When replacing a drive in an application and before returning to use, it is essential that all user defined parameters for the product's operation are correctly installed.
- This equipment contains electrostatic discharge (ESD) sensitive parts. Observe static control precautions when handling, installing and servicing this product.

IMPORTANT: Metal parts may reach a temperature of 90 degrees centigrade in operation.

Application Risk

The specifications, processes and circuitry described herein are for guidance only and may need to be adapted to the user's specific application.

Eurotherm Drives does not guarantee the suitability of the equipment described in this Manual for individual applications.

Risk Assessment

Under fault conditions, power loss or other operating conditions not intended, the equipment may not operate as specified. In particular:

- The motor speed may not be controlled
- The direction of rotation of the motor may not be controlled
- The motor may be energised

Guards

The user must provide guarding and /or additional safety systems to prevent risk of injury and electric shock.

Protective Insulation

- All control and signal terminals are SELV, i.e. protected by double insulation. Ensure all wiring is rated for the highest system voltage.

Note: *Thermal sensors contained within the motor must be double insulated.*

- All exposed metalwork in the Converter is protected by basic insulation and bonding to a safety earth.

RCDs

These are not recommended for use with this product but ,where their use is mandatory, only Type B RCDs should be used.

Contents

Contents

Page

Chapter 1 GETTING STARTED

Equipment Inspection and Storage	1-2
Packaging and Lifting Details	1-2
About this Manual	1-2
Initial Steps	1-2
How the Manual is Organised	1-3

Chapter 2 AN OVERVIEW OF THE CONVERTER

How it Works	2-1
Control Features	2-2
Understanding the Product Code	2-3
Model Number (Europe).....	2-3
Catalog Number (North America).....	2-4
• Door Assembly Product Code	2-5
Product Identification	2-5
Component Identification	2-6
• 590+ Controller (Frames 1 & 2).....	2-6
• 590+ Door Assembly (Frames 3, 4, 5 & H).....	2-7
• 590+ Controller (Frame 3).....	2-8
• 590+ Controller (Frames 4 & 5).....	2-9
• 590+ Product (Frame H)	2-10

Chapter 3 INSTALLING THE CONVERTER

Mechanical Installation	3-1
Unpacking the Converter	3-1
• Lifting the Converter	3-1
Changing DC Output Terminals (Frame H)	3-2
Removing the Cover (Frame H).....	3-2
Product Dimensions	3-3
Mounting the Converter.....	3-4
• Recommended Tools	3-4
• Ventilation and Cooling Requirements.....	3-4
AC Line Choke	3-4
Installing the Fan (Frame H)	3-5
Installing the External Vent Kit (Frames 4 & 5)	3-5
Electrical Installation	3-6
Minimum Connection Requirements (Frames 1, 2, 3, 4 & 5)	3-8
• Important Connections	3-8
• Protective Earth Connections (PE) - (Frames 1, 2, 3, 4 & 5)	3-9
• Power Wiring Connections (Frames 1, 2, 3, 4 & 5)	3-10
• Control Wiring Connections (Frames 1, 2, 3, 4 & 5)	3-13
Minimum Connection Requirements (Frame H)	3-17
• Protective Earth Connections (PE) - (Frame H).....	3-18
• Power Wiring Connections (Frame H).....	3-19
• Control Wiring Connections (Frame H)	3-21

Cont.5

Contents

<i>Contents</i>	<i>Page</i>
Motor Field Connections	3-22
• Internal/External Supply (Frames 2, 3, 4 & 5)	3-22
DC Contactor - External VA Sensing	3-25
• Power Board - PCB Reference 385851 (Frame 3)	3-25
• Power Board – PCB Reference 466701 (Frames 4 & 5)	3-25
• External Connections (Frame H)	3-26
Optional Equipment	3-27
• Fitting the Remote 6901 Operator Station	3-27
• Speed Feedback and Technology Options	3-28
• External AC Supply EMC Filter Installation	3-29
• Earth Fault Monitoring Systems	3-30
Installation Drawings	3-31
Converter Installation Drawings	3-31
Filter Installation Drawings	3-42
Line Choke Installation Drawings	3-48

Chapter 4 OPERATING THE CONVERTER

Pre-Operation Checks	4-1
Control Philosophy	4-2
Start/Stop and Speed Control	4-2
• Selecting Local or Remote Control	4-3
Reading the Status LEDs	4-3
Setting-up the Converter	4-4
Preliminaries	4-4
• Analog Tacho Calibration Option Board	4-4
• Microtach/Encoder Feedback Option Board	4-5
Calibration	4-5
Selecting Speed Feedback	4-7
Initial Start-up Routine	4-8
Performance Adjustment	4-14
• Current Loop - The Autotune Feature	4-14
• Speed Loop	4-14
Starting and Stopping Methods	4-15
Stopping Methods	4-15
• Normal Stop (C3)	4-16
• Program Stop (B8)	4-18
• Coast Stop (B9)	4-19
• Standstill	4-19
• The Trip Condition	4-19
Normal Starting Method	4-20
Advanced Starting Methods	4-20
• Starting Several Converters Simultaneously	4-20
• Jog	4-20
• Crawl	4-20

Contents

Contents

Page

Chapter 5 THE OPERATOR STATION

Connecting the Operator Station	5-1
Controlling the Operator Station	5-1
Control Key Definitions.....	5-2
• Keys for Programming the Converter	5-2
• Keys for Operating the Converter Locally	5-2
Indications	5-3
• Operator Station LEDs.....	5-3
• Operator Station Alarm Messages	5-3
The Menu System	5-4
The Local Menu	5-5
• The L/R Key.....	5-5
• The PROG Key	5-5
Navigating the Menu System	5-6
Changing a Parameter Value	5-6
The Menu System Map	5-7
Menu Shortcuts and Special Key Combinations	5-8
• Quick Tag Information	5-8
• Changing the Stack Size (3-button reset)	5-8
• Resetting to Factory Defaults (2-button reset)	5-9
Special Menu Features	5-10
Selecting a Menu Viewing Level	5-10
Selecting the Display Language	5-10
Password Protection	5-11
• To Activate Password Protection	5-11
• To Deactivate Password Protection	5-12
How to Save, Restore and Copy your Settings	5-13
Saving Your Application	5-13
Restoring Saved Settings.....	5-13
Copying an Application.....	5-13

Chapter 6 PROGRAMMING YOUR APPLICATION

Programming with Block Diagrams.....	6-1
Modifying a Block Diagram	6-1
• Configuration and Parameterisation Modes	6-1
• Making and Breaking Links in Configuration Mode	6-1
• Programming Rules	6-2
• Saving Your Modifications	6-2
Understanding the Function Block Description	6-2
• MMI Menu Maps.....	6-3
Function Block Descriptions.....	6-4
• ANALOG INPUTS.....	6-5
• ANALOG OUTPUTS	6-7
• AUX I/O.....	6-8
• BLOCK DIAGRAM (MMI only)	6-13

Cont.7

Contents

<i>Contents</i>	<i>Page</i>
• CALIBRATION	6-14
• CONFIGURE DRIVE (MMI only).....	6-17
• CURRENT LOOP	6-18
• CURRENT PROFILE.....	6-21
• DIAGNOSTICS.....	6-22
• DIAMETER CALC.	6-27
• DIGITAL INPUTS	6-29
• DIGITAL OUTPUTS.....	6-31
• FIELD CONTROL.....	6-32
• ALARMS	6-35
• JOG/SLACK.....	6-38
• LINK 11 & LINK 12.....	6-40
• MENUS.....	6-42
• miniLINK.....	6-43
• OP STATION.....	6-44
• PASSWORD (MMI only)	6-46
• PID	6-47
• RAISE/LOWER.....	6-50
• RAMPS	6-52
• SETPOINT SUM 1	6-56
• SETPOINT SUM 2.....	6-57
• SPEED LOOP	6-59
• ADVANCED	6-63
• STANDSTILL.....	6-64
• STOP RATES.....	6-65
• SYSTEM PORT P3	6-67
• 5703 SUPPORT.....	6-68
• TAPER CALC.	6-69
• TEC OPTION	6-70
• TENS+COMP CALC.....	6-71
• TORQUE CALC.....	6-73
• USER FILTER.....	6-74

Chapter 7 TRIPS AND FAULT FINDING

Trips	7-1
What Happens when a Trip Occurs	7-1
• Converter Indications.....	7-1
• Operator Station Indications	7-1
Resetting a Trip Condition	7-1
Fault Finding	7-2
Alarm Messages	7-2
• LAST ALARM	7-2
• HEALTH WORD.....	7-2
• HEALTH STORE.....	7-2

Contents

<i>Contents</i>	<i>Page</i>
Hexadecimal Representation of Trips	7-3
Power Board LED Trip Information (Frame 4, 5 & H)	7-4
Using the MMI to Manage Trips.....	7-5
• Trip Messages	7-5
• Symbolic Alarm Messages	7-8
• Self Test Alarms.....	7-8
• Setting Trip Conditions	7-8
• Viewing Trip Conditions.....	7-9
• Inhibiting Alarms	7-9
Test Points.....	7-9

Chapter 8 ROUTINE MAINTENANCE AND REPAIR

Maintenance	8-1
• Service Procedures	8-1
• Preventive Maintenance	8-1
Repair.....	8-1
Saving Your Application Data	8-1
Returning the Unit to Eurotherm Drives.....	8-2
Disposal	8-2
Technical Support Checks.....	8-3
Fuse Replacement (Frame H)	8-4
• 590+ 4Q Product (Regenerative)	8-4
• 591+ 2Q Product (Non-Regenerative)	8-5
Phase Assembly Replacement (Frame H)	8-6
Replacing the Fan (Frames 4 & 5).....	8-8

Chapter 9 CONTROL LOOPS

Principle of Operation.....	9-1
Current Loop	9-1
• Manual Tuning.....	9-2
Speed Loop	9-4
Field Control.....	9-4
• Set-up Notes	9-4
• Current Control.....	9-5
• Voltage Control.....	9-5
• Field Weakening	9-5
• Standby Field	9-5

Chapter 10 PARAMETER SPECIFICATION TABLE

Specification Table: Tag Number Order	10-2
Parameter Table: MMI Menu Order	10-18

Contents

Contents

Page

Chapter 11 TECHNICAL SPECIFICATIONS

Environmental Details	11-1
EMC Compliance.....	11-1
Electrical Ratings - Power Circuit	11-2
Power Supply Details	11-3
Auxiliary Power Supply Details	11-3
AC Line Choke (Frames 1, 2, 3, 4 & 5)	11-4
AC Line Choke (Frame H)	11-5
External AC Supply (RFI) Filters	11-5
Power Semiconductor Protection Fuses (Frames 1, 2, 3, 4 & 5)	11-6
Power Semiconductor Protection Fuses (Frame H).....	11-6
Power Supply Fuses	11-7
Field Fuses.....	11-7
Earthing/Safety Details	11-7
Terminal Definitions (Digital/Analog Inputs & Outputs).....	11-8
Terminal Information - Power Board (Frames 1, 2, 4 & 5).....	11-9
Terminal Information – Control Board	11-12
Terminal Information (Frame H)	11-16
Terminal Information – Option Boards.....	11-17
Wiring Requirements for EMC Compliance	11-17
Wire Sizes and Termination Tightening Torques (Frames 1, 2, 3, 4 & 5).....	11-18
Termination Tightening Torque (Frame H).....	11-19
Cooling Fans	11-19
Spares List	11-20

Chapter 12 CERTIFICATION FOR THE CONVERTER

Requirements for EMC Compliance	12-1
Minimising Radiated Emissions	12-1
Earthing Requirements	12-1
• Protective Earth (PE) Connections	12-1
• Control/Signal EMC Earth Connections.....	12-2
Cabling Requirements	12-2
• Planning Cable Runs	12-2
• Increasing Motor Cable Length.....	12-2
EMC Installation Options.....	12-3
• Screening & Earthing (cubicle mounted, Class A).....	12-3
• Star Point Earthing.....	12-4
• Sensitive Equipment.....	12-5
Requirements for UL Compliance.....	12-6
• Motor Overload Protection.....	12-6
• Branch Circuit/Short Circuit Protection Requirements	12-6
• Short Circuit Ratings	12-6
• Field Wiring Temperature Rating.....	12-7
• Operating Ambient Temperature	12-7
• Field Wiring Terminal Markings	12-7

Contents

<i>Contents</i>	<i>Page</i>
• Power and Control Field Wiring Terminals.....	12-7
• Field Grounding Terminals	12-7
• Field Terminal Kits.....	12-7
• Fuse Replacement Information	12-7
Recommended Wire Sizes (Frames 1, 2, 4 & 5).....	12-8
Recommended Wire Sizes (Frame H)	12-8
European Directives and the CE Mark	12-9
CE Marking for Low Voltage Directive	12-9
CE Marking for EMC - Who is Responsible?	12-9
• Legal Requirements for CE Marking	12-10
• Applying for CE Marking for EMC	12-10
Which Standards Apply?	12-11
• Basic and Generic Standards	12-11
Certificates.....	12-13

Chapter 13 STANDARD AND OPTIONAL EQUIPMENT

Standard Equipment	13-1
Power Board Circuit Descriptions	13-1
• AH470280U001, U002, U003, U004 (Frame 1)	13-1
• AH470330 (Frame 2).....	13-3
• AH385851U002, U003, U004, U005 (Frame 3)	13-5
• AH466701U001, U002, U003 (Frames 4 & 5)	13-10
• AH466001U001, U101 (Frame H)	13-13
Optional Equipment	13-16
Speed Feedback Option Boards	13-16
• Microtach Option Board	13-17
• Wire-Ended Encoder Option Board	13-17
• Tacho Calibration Option Board	13-17
• Combined Tacho and Encoder Feedback	13-18
Communications Technology Options.....	13-18
• COMMS Option Technology Box	13-18

Chapter 14 SERIAL COMMUNICATIONS

Communications Technology Option.....	14-1
Config Ed Lite	14-1
System Port (P3)	14-1
UDP Support.....	14-1
• UDP Menu Structure	14-2
• UDP Transfer Procedure	14-2
• MMI Dump	14-3
5703 Support	14-4
• Commissioning the 5703/1	14-5
Error Codes.....	14-6
ERROR REPORT (EE)	14-6

Contents

Contents

Page

Chapter 15 THE DEFAULT APPLICATION

Block Diagrams.....	15-1
Programming Block Diagram - Sheet 1	15-3
Programming Block Diagram - Sheet 2	15-4
Main Block Diagram	15-5
Field Control Block Diagram	15-6
Start/Healthy Logic Block Diagram	15-7
Functional Block Diagram	15-8

GETTING STARTED

System Design

The 590+ Series Converter is designed for use in a suitable enclosure, with associated control equipment. The unit accepts a variety of standard three-phase ac supply voltages depending upon the model, and is suitable for the powering of DC shunt field and permanent magnet motors, providing controlled dc output voltage and current for armature and field.

All units are designed for simple and economical panel mounting using keyhole slots. Plug-in control connectors simplify the fitting and removal of the unit to the panel.

Where possible, standard parts are used throughout the range thereby reducing the variety of spare parts required to maintain a multi-drive system. For example, the same basic control boards are used in all types of three-phase armature controller regardless of horsepower or bridge configuration.

The control circuit is totally isolated from the power circuit thus simplifying the interconnection of controllers within a system and improving operator safety. The coding circuitry adjusts automatically to accept supply frequencies between 45-65Hz and possesses high immunity to supply-borne interference. The armature controllers are phase rotation insensitive.

Control and Communications

The Converter is controlled by a 16 bit Microcontroller providing advanced features such as:

- **Complex control algorithms** which are not achievable by simple analog techniques.
- **Software-configurable control circuitry** built around standard software blocks.
- **Serial link communications** with other drives or a PC for advanced process systems.

The Operator Station gives access to parameters, diagnostic messages, trip settings and full application programming.

Regenerative and Non-Regenerative Models

The motor armature controllers include both regenerative and non-regenerative models:

- **Regenerative controllers** consist of two fully-controlled thyristor bridges and a field bridge with full transient and overload protection, together with sophisticated electronic control of acceleration and deceleration, speed and torque in both directions of rotation.
- **Non-regenerative controllers** consist of one fully-controlled thyristor bridge and a field bridge with full transient and overload protection, together with its associated electronic control circuitry, and provide accurate speed and/or torque control in one selected direction of rotation.

Field Regulator

A field regulator is fitted as standard. The regulator consists of a full-wave half controlled single phase thyristor bridge with transient and overload protection. It provides either a fixed voltage or fixed current source, depending upon the selected mode of operation for constant torque applications. The field current mode of operation can be further enhanced to provide field weakening for drive control motors which require extended speed or constant horsepower control.

1-2 Getting Started

Equipment Inspection and Storage

- Check for signs of transit damage
- Check the product code on the rating label conforms to your requirement.

If the unit is not being installed immediately, store the unit in a well-ventilated place away from high temperatures, humidity, dust, or metal particles.

Refer to Chapter 2: “An Overview of the Converter” to check the rating label/product code.
Refer to Chapter 8: “Routine Maintenance and Repair” for information on returning damaged goods.

Refer to Chapter 11: “Technical Specifications” - Environmental Details for the storage temperature.

Packaging and Lifting Details

Caution

The packaging is combustible and, if disposed of in this manner incorrectly, may lead to the generation of lethal toxic fumes.

Save the packaging in case of return. Improper packaging can result in transit damage.

Use a safe and suitable lifting procedure when moving the drive. Never lift the drive by its terminal connections.

Prepare a clear, flat surface to receive the drive before attempting to move it. Do not damage any terminal connections when putting the drive down.

Refer to Chapter 11: “Technical Specifications” - Mechanical Details for unit weights.

About this Manual

This manual is intended for use by the installer, user and programmer of the 590+ Series Converter. It assumes a reasonable level of understanding in these three disciplines.

Note: *Please read all Safety Information before proceeding with the installation and operation of this unit.*

Enter the “Model No” from the rating label into the table at the front of this manual. There is also a column for you to record your application’s parameter settings in the table in Chapter 10. It is important that you pass this manual on to any new user of this unit.

This manual is for the following models from the 590+ Converter Series:

- Three phase, regenerative, four quadrant armature controllers:
590+
- Three phase non-regenerative, two quadrant armature controllers:
591+
- 590+ Door

Initial Steps

Use the manual to help you plan the following:

Installation

Know your requirements:

- certification requirements, CE/UL/c-UL conformance
- conformance with local installation requirements
- supply and cabling requirements

Operation

Know your operator:

- how is it to be operated, local and/or remote?
- what level of user is going to operate the unit?
- decide on the best menu level for the Operator Station (where supplied)

Programming (Operator Station or suitable PC programming tool only)

Know your application:

- plan your “block diagram programming”
- enter a password to guard against illicit or accidental changes
- learn how to back-up your application data
- customise the Operator Station to the application

How the Manual is Organised

The manual is divided into chapters and paragraphs. Page numbering restarts with every chapter, i.e. 5-3 is Chapter 5, page 3.

Application Block Diagram

You will find this at the rear of the manual. The pages unfold to show a complete block diagram, this will become your programming tool as you become more familiar with the software.

1-4 Getting Started

AN OVERVIEW OF THE CONVERTER

How it Works

Note: Refer to Chapter 9: "Control Loops" for a more detailed explanation.

In *very* simple terms, the Converter controls the dc motor with the use of *Control Loops* - an inner Current Loop and an outer Speed Loop. These control loops can be seen in the Application Block Diagram. The block diagram shows all the Converter's software connections.

Using the Operator Station, you can select the control loops to be used by the Converter to provide either:

- Current Control
- Speed Control (default)

It is usual to supply a Current or Speed Feedback signal to the appropriate loop for more effective control of the Converter. Current Feedback sensors are built-in, whereas Speed Feedback is provided directly from the armature sensing circuit (default), or by tachogenerator, encoder or Microtach connection to the relevant option board.

When in Speed Control, you can modify the performance of the Converter further by controlling the motor field, i.e. Field Control. By weakening the field current, you can obtain an increase in motor speed beyond that normally achievable for the rated Armature Voltage of the dc motor.

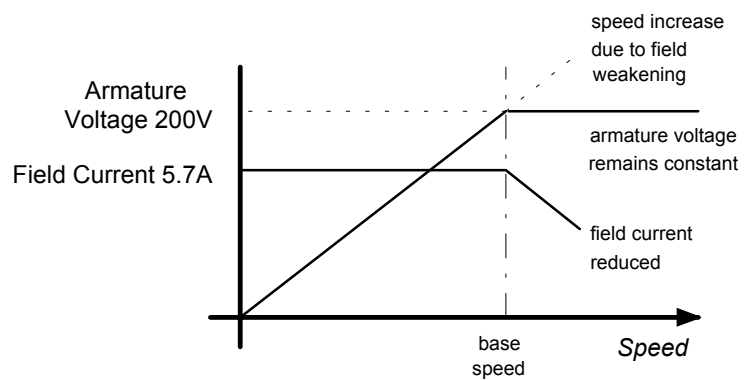

The Converter is controlled remotely using digital/analog inputs and outputs, or locally using the Operator Station.

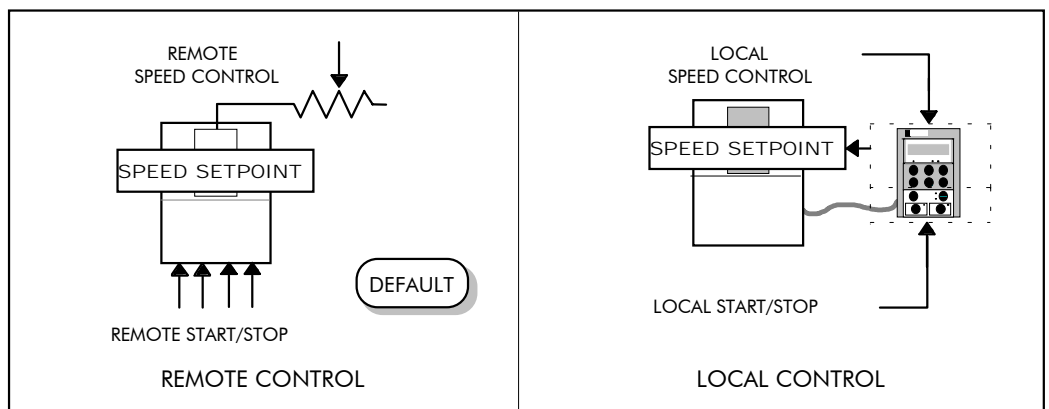

By plugging in a COMMS Option Technology Box, the Converter can be linked into a network and controlled by a PLC/SCADA or other intelligent device.

2-2 An Overview of the Converter

Control Features

Control	Control Circuits	Fully isolated from power circuit (SELV)
	Output Control	<ul style="list-style-type: none"> • Fully controlled 3-phase thyristor bridge • Microprocessor implemented phase control extended firing range • For use on 50 or 60Hz supplies with a frequency compliance range of 45 to 65Hz • Phase control circuits are phase rotation insensitive
	Control Action	<ul style="list-style-type: none"> • Fully digital • Advanced PI with fully adaptive current loops for optimum dynamic performance • Self Tuning Current Loop utilising "Autotune" algorithm • Adjustable speed PI with integral defeat
	Speed Control	<ul style="list-style-type: none"> • By Armature Voltage feedback with IR compensation • By Encoder feedback or analog tachogenerator
	Speed Range	100 to 1 typical with tachogenerator feedback
	Steady State Accuracy	<ul style="list-style-type: none"> • 0.01 % Encoder Feedback with Digital setpoint (serial link or P3) • 0.1 % Analog Tach Feedback • 2 % Voltage Feedback • Absolute (0.0% error) using QUADRALOC Mk II 5720 Digital Controller <p>Note: Long term analog accuracy is subject to tachogenerator temperature stability.</p>
	Adjustments	All adjustments in software can be altered by the Operator Station or via serial communications. The Operator Station provides monitoring and adjustment of parameters and levels, in addition to diagnostic facilities.
Protection		<ul style="list-style-type: none"> • High energy MOVs • Overcurrent (instantaneous) • Overcurrent (inverse time) • Field failure • Speed feedback failure • Motor overtemperature • Thyristor Stack overtemperature • Thyristor "Trigger" failure • Thyristor Snubber Network • Zero-speed detection • Standstill logic • Stall protection
Diagnostics		<ul style="list-style-type: none"> • Fully computerised with first fault latch and automatic display • Digital LCD monitoring • Full diagnostic information available on RS422/RS485 • LED circuit state indication

Table 2-1 Control Features

Understanding the Product Code

Model Number (Europe)

The unit is fully identified using an alphanumeric code which records how the Converter was calibrated, its various settings when despatched from the factory, and the country of origin.

The Product Code appears as the “Model No”. Each block of the Product Code is identified as below:

Model Number (Europe)		
Block No.	Variable	Description
1	XXXX	Generic product 590P : 590+ 4Q DC Drive 591P : 590+ 2Q DC Drive
2	XXXX	Four digits identifying the maximum dc output current rating that may be calibrated for each size of product: 0015 = 15A (Frame 1) 0035 = 35A (Frame 1) 0040 = 40A (Frame 2) 0070 = 70A (Frame 2) 0110 = 110A (Frame 2) 0165 = 165A (Frame 2) 0180 = 180A (Frame 3) 0270 = 270A (Frame 3) 0380 = 380A (Frame 4) 0500 = 500A (Frame 4) 0725 = 725A (Frame 4) 0830 = 830A (Frame 4) 1580 = 1580A (Frame 5) 1200 = 1200A (Frame H) 1700 = 1700A (Frame H) 2200 = 2200A (Frame H) 2700 = 2700A (Frame H)
3	XXX	3 digits identifying the nominal 3 phase ac power, supply voltage: 220 110 to 220V (±10%) 50/60Hz 500 220 to 500V (±10%) 50/60Hz 600 500 to 600V (±10%) 50/60Hz (Frame 4 & 5 only) 690 500 to 690V (±10%) 50/60Hz (Frame H only)
4	XXXX	4 digits describing the mechanical package including livery and mechanical package style: <i>First two digits (on the left)</i> <i>Livery</i> 00 Standard Eurotherm Livery 05 Distributor Livery 01-04 and 06-99 Defined customer liveries TBA <i>Third digit</i> <i>Mechanical Package Style</i> 1 Standard (IP20), protected panel mounting 4 Panel Mounting IP20 plus Roof Vent Kit (Frame 4 only) <i>Fourth digit</i> <i>Operator Station</i> 0 No operator station 1 Built-in 6901 operator station
5	XX	Two characters specifying the user interface language: UK = English FR = French GR = German (refer to Customer Services) SP = Spanish (refer to Customer Services) IT = Italian (refer to Customer Services)

Door Assembly Product Code

The door assembly is identified separately. The Product Code appears on a label displayed under the terminal cover.

Block No.	Variable	Description
1	XXXXX	Generic product 590PD : Fits Frame 4 and 5 units 590PXD : Fits Frame 3 and H units
2	XXXX	4 digits describing the mechanical package including livery and mechanical package style: <i>First two digits (on the left)</i> <i>Livery</i> 00 Standard Eurotherm Livery 05 Distributor Livery 01-04 and 06-99 Defined customer liveries TBA <i>Third digit</i> <i>Mechanical Package Style</i> 1 Standard <i>Fourth digit</i> <i>Operator Station</i> 0 No operator station 1 Built-in operator station
3	XX	Two characters specifying the user interface language: UK = English FR = French GR = German (refer to Customer Services) SP = Spanish (refer to Customer Services) IT = Italian (refer to Customer Services)
4	XXX	Up to three characters specifying engineering special options: 0 = No special option

Product Identification

Output Currents (armature):

Frame 1	Frame 2	Frame 3	Frame 4	Frame 5	Frame H
15A 35A	40A 70A 110A 165A	180A 270A	380A 500A 725A 830A	1580A	1200A 1700A 2200A 2700A

All units are available as a:

- 590+ : 4Q 3-phase, fully controlled, anti-parallel thyristor bridge configuration
- 591+ : 2Q 3-phase, fully controlled thyristor bridge configuration

2-6 An Overview of the Converter

Component Identification

590+ Controller (Frames 1 & 2)

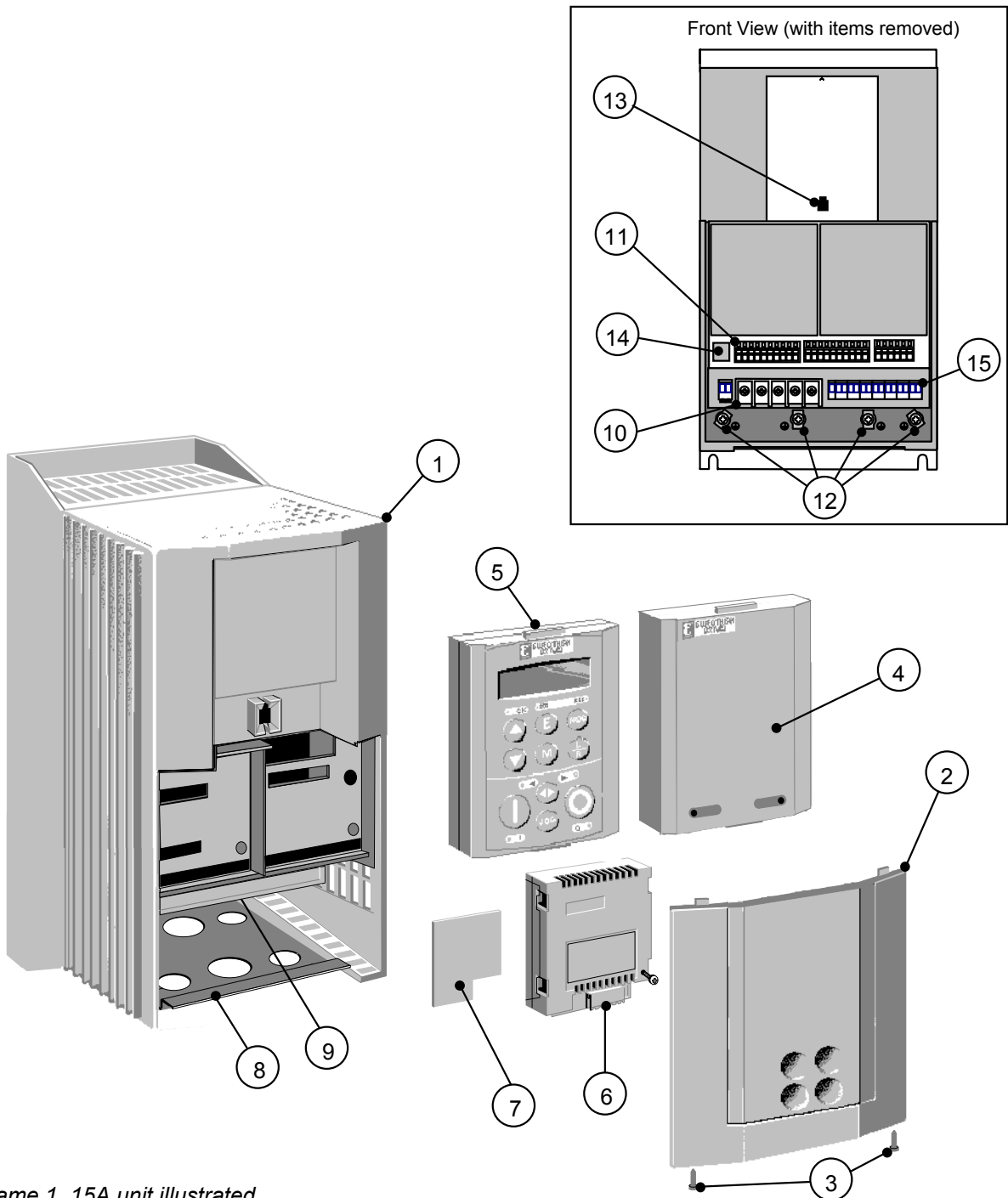

Frame 1, 15A unit illustrated

- | | |
|--|---|
| 1 Main converter assembly | 9 Power terminal shield |
| 2 Terminal cover | 10 Power terminals |
| 3 Terminal cover retaining screw | 11 Control terminals |
| 4 Blank cover | 12 Earthing points |
| 5 6901 operator station (optional) | 13 Operator station port |
| 6 COMMS technology box (optional) | 14 RS232 programming port |
| 7 Speed feedback technology card (optional) | 15 Auxiliary power, external contactor and isolated thermistor terminals |
| 8 Gland plate | |

590+ Door Assembly (Frames 3, 4, 5 & H)

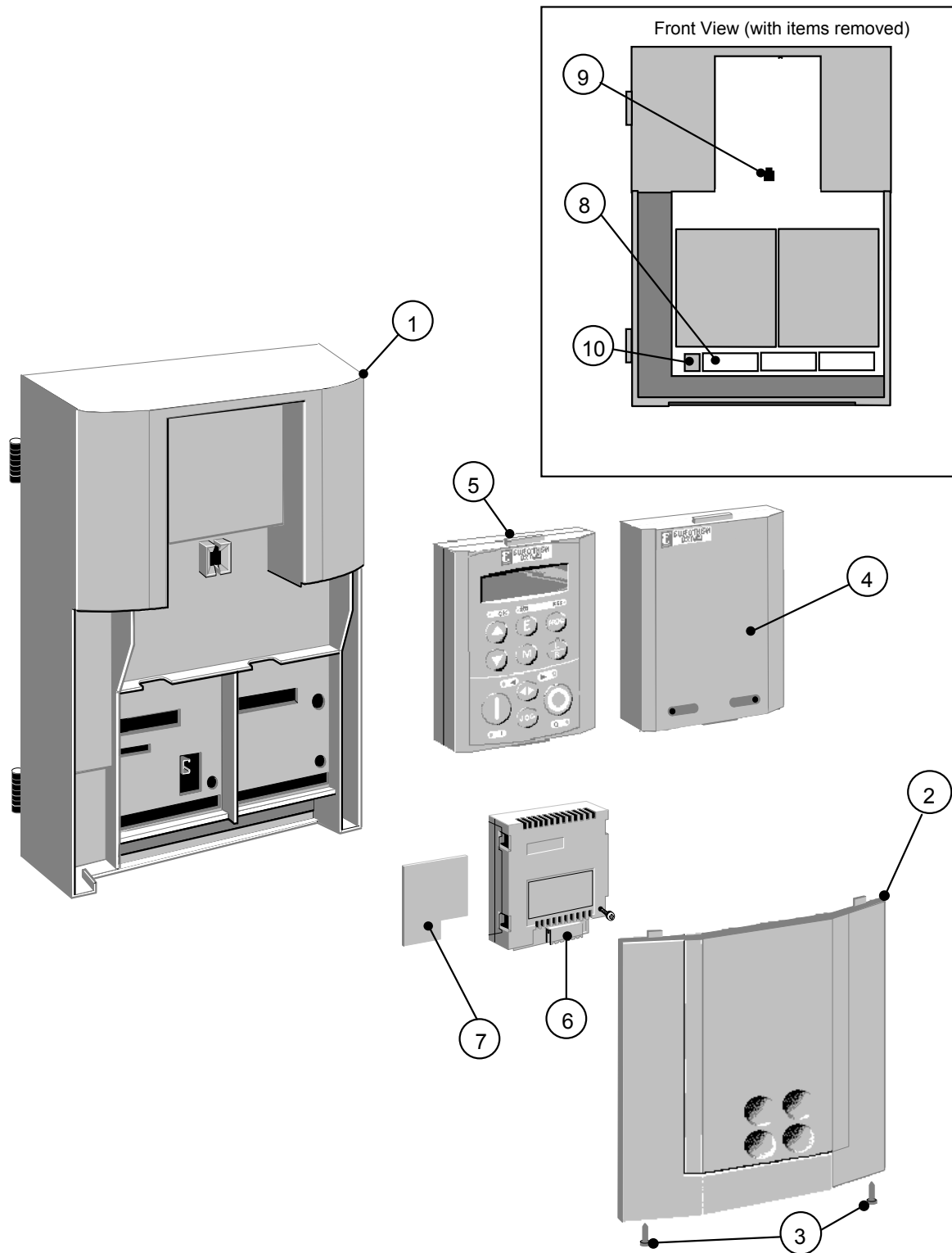

Frames 4 & 5 : Product Code 590PD/.... (illustrated)

Frames 3 & H : Product Code 590PXD/.... (with additional motor thermistor terminals)

1 Main door assembly	7 Speed feedback technology card (optional)
2 Terminal cover	8 Control terminals
3 Terminal cover retaining screw	9 Operator station port
4 Blank cover	10 RS232 programming port (P3)
5 6901 operator station (optional)	
6 COMMS technology box (optional)	

2-8 An Overview of the Converter

590+ Controller (Frame 3)

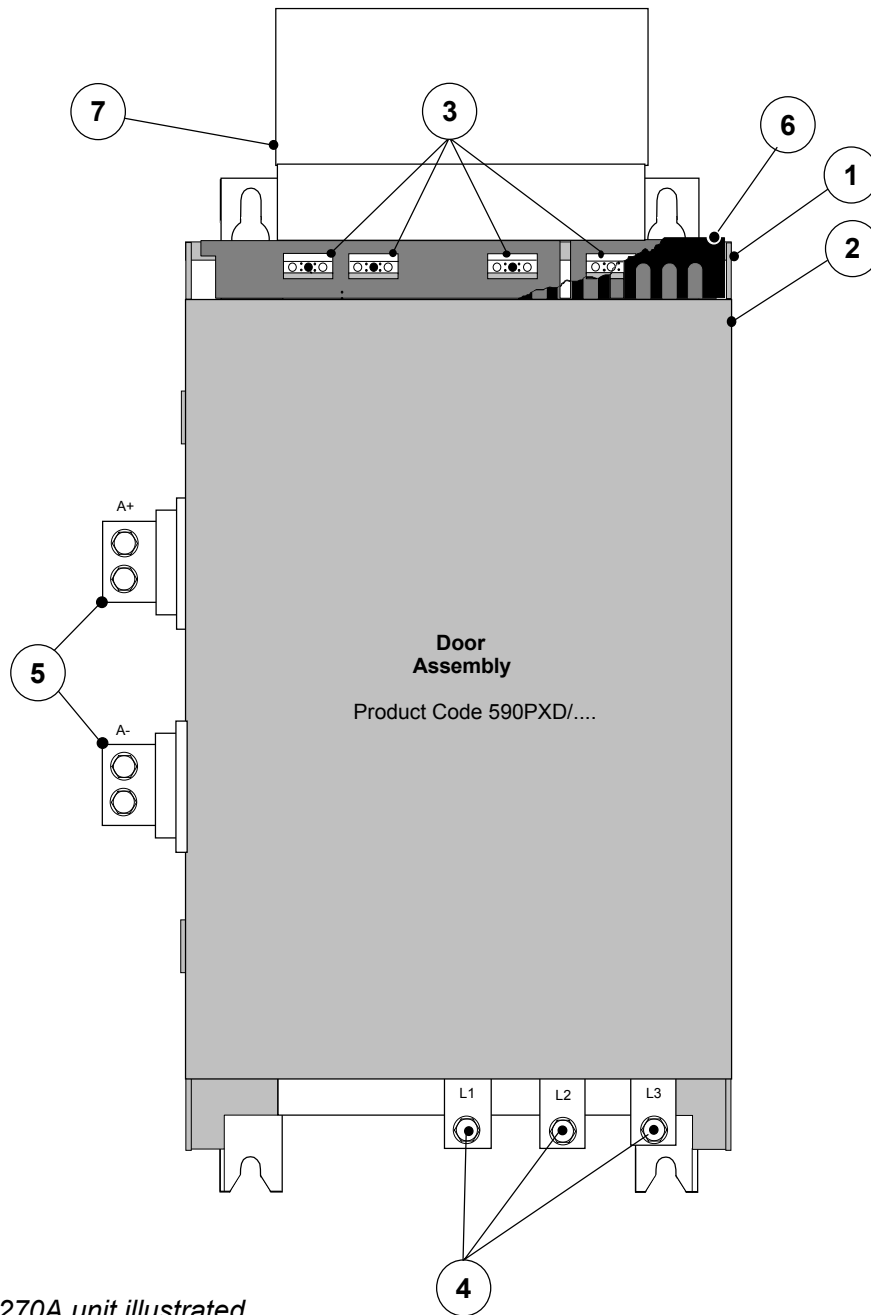

- | | | | |
|----------|----------------------------|----------|---------------------------------|
| 1 | Main converter assembly | 5 | Busbars - main power output |
| 2 | Door assembly | 6 | IP20 Top Cover |
| 3 | Field wiring terminals | 7 | IP20 Fan Housing (where fitted) |
| 4 | Busbars - main power input | | |

590+ Controller (Frames 4 & 5)

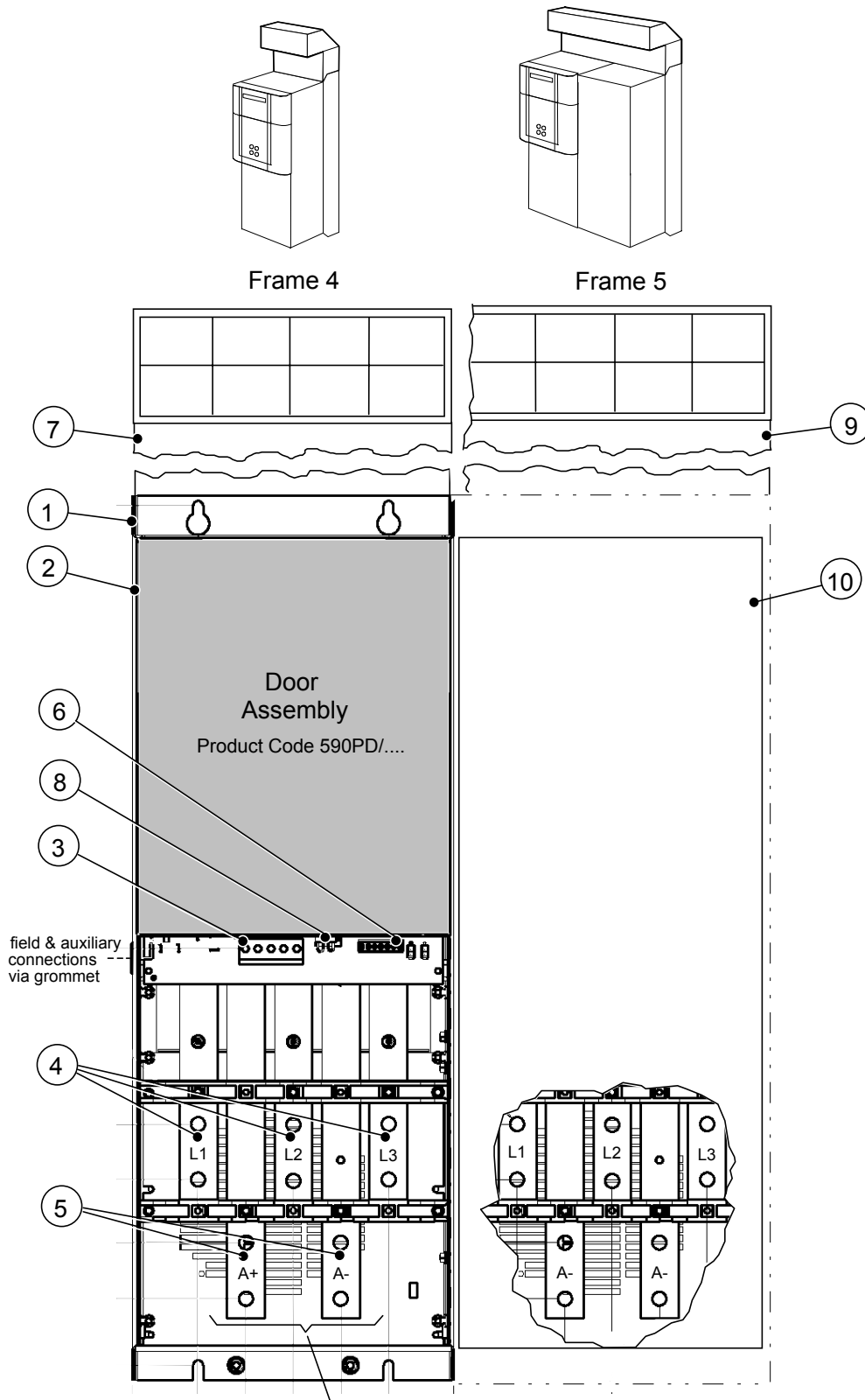

When Frame 5, both terminals are for A+ connections

1 Main converter assembly	6 Auxiliary supply, contactor and motor thermistor terminals
2 Standard door assembly	7 Frame 4 External vent (where fitted)
3 Motor field terminals	8 Contactor Control Select
4 Busbars - main power input	9 Frame 5 External vent (where fitted)
5 Busbars - main power output	10 Terminal Cover (Frame 5)

2-10 An Overview of the Converter

590+ Product (Frame H)

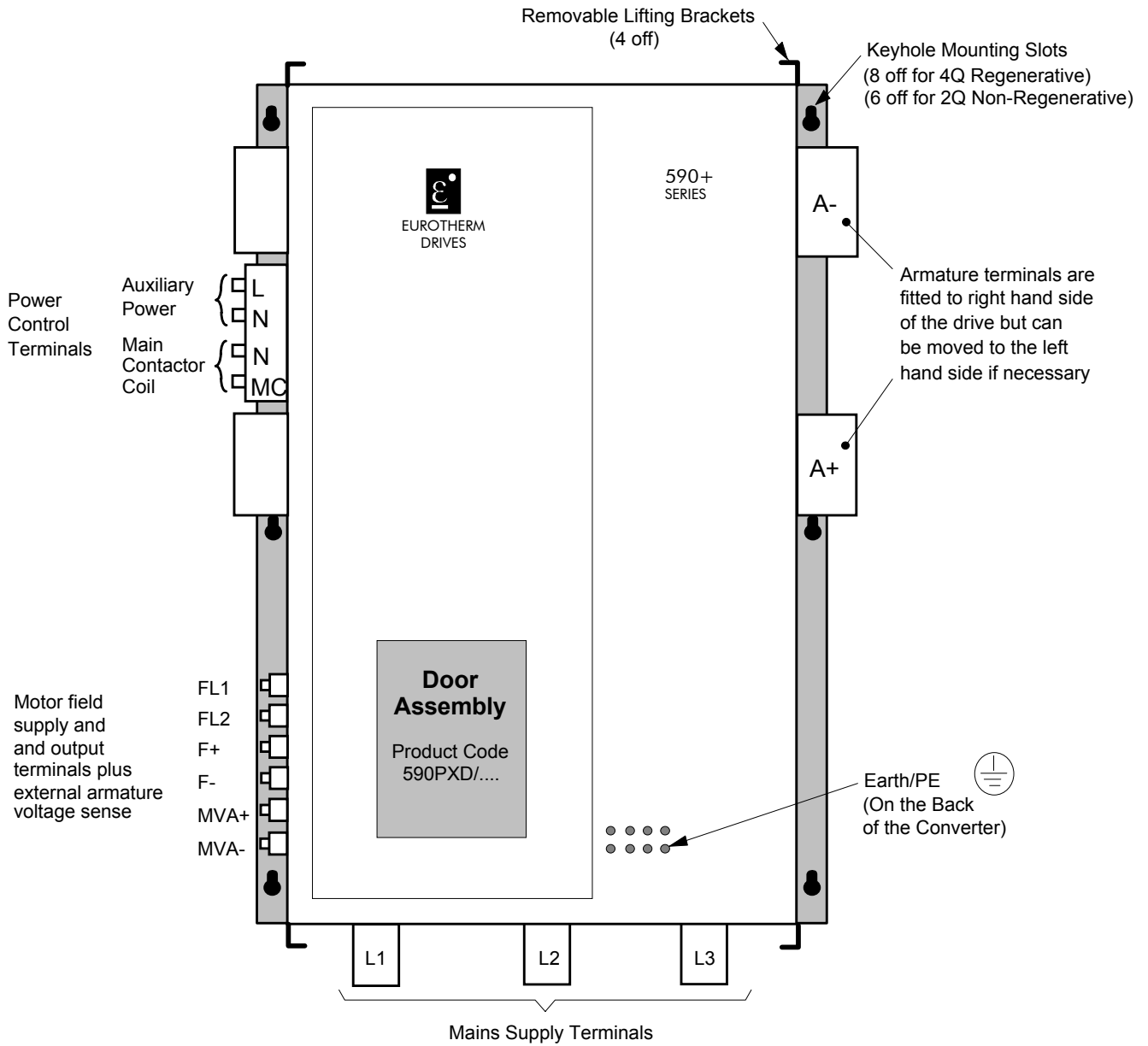

INSTALLING THE CONVERTER

IMPORTANT: Read Chapter 12: "Certification for the Converter" before installing this unit. Refer to "Installation Drawings", page 3-31 for further information.

Mechanical Installation

Unpacking the Converter

Caution

The packaging is combustible and, if disposed of in this manner incorrectly, may lead to the generation of lethal toxic fumes.

Save the packaging in case of return. Improper packaging can result in transit damage.

Frame H Packaging

The larger converters (Frame H) are supplied in special packaging to protect the drive whilst in transit. Remove all fixings from the drive, see Figure 3-1. (The packaging is designed so that the sides can be removed to reveal the drive).

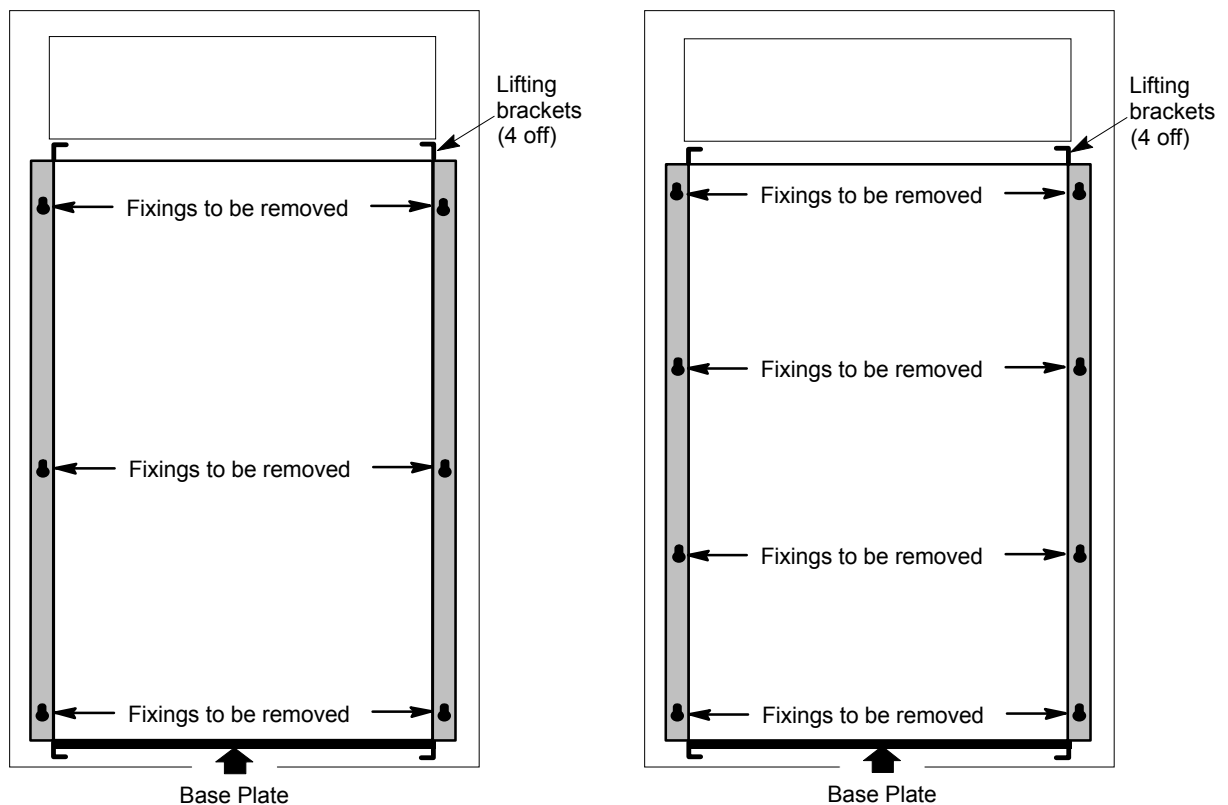

591+ 2Q Non-Regenerative Mounting Positions

590+ 4Q Regenerative Mounting Positions

Figure 3-1 Lifting Details (Frame H)

Lifting the Converter

Use a safe and suitable lifting procedure when moving the drive. Never lift the drive by its terminal connections. Refer to Chapter 11: Technical Specifications - Mechanical Details for weights.

Prepare a clear, flat surface to receive the drive before attempting to move it. Do not damage any terminal connections when putting the drive down.

3-2 Installing the Converter

The larger converters (H) require the following:

- The drive is supplied with a lifting bracket fitted to each corner for hoisting. Remove the brackets when the drive is in its final position, however, **the fixings MUST be re-fitted**. Refer to Chapter 11: “Technical Specifications” - Fixing Types and Torques.
- A plate is fitted to the base to enable the drive to be set-on-end by a forklift. Remove the plate before wiring the power terminals.

Frames 4 & 5 converters also have lifting eyes and a plate fitted to the base to enable the drive to be set-on-end by a forklift. Remove the plate before wiring the power terminals.

Changing DC Output Terminals (Frame H)

- Remove the left-hand cover plate(s) and retain the cover and screws.
- Remove and retain the 12 M6 nuts clamping the outgoing terminals to the cross plates.
- Remove the 12 M6 bolts securing the outgoing busbar assembly (assemblies). Remove the assembly (assemblies).
- Carefully remove the gasket(s) for use on the left-hand side.
- Refit the cover to the right-hand side of the drive.
- Refit the gasket to the left-hand side of the drive.
- Refit the terminal assemblies.

Note: The 2Q terminal assembly is not polarised and may be fitted in any orientation. The 4Q terminal assemblies are handed and must be reversed to fit on the left-hand side.

- Move the terminal markers as appropriate, the A+ terminal will still be at the bottom or AC input at the end of the product.
- Tighten terminal assembly bolts to the torque given in Chapter 11.

Removing the Cover (Frame H)

The cover is manufactured from sheet metal and weighs:-

- 2Q Non-Regenerative = 10kg (22 lbs)
- 4Q Regenerative = 15kg (33 lbs)

To remove the cover use a flat headed screwdriver to undo the two screws at the base of the cover.

Now lift the cover base outwards and upwards, once the cover has been raised two centimetres it can now be removed.

To replace the cover follow the procedure in reverse, engaging the locating studs at the top, moving into final location and tightening fixing screws.

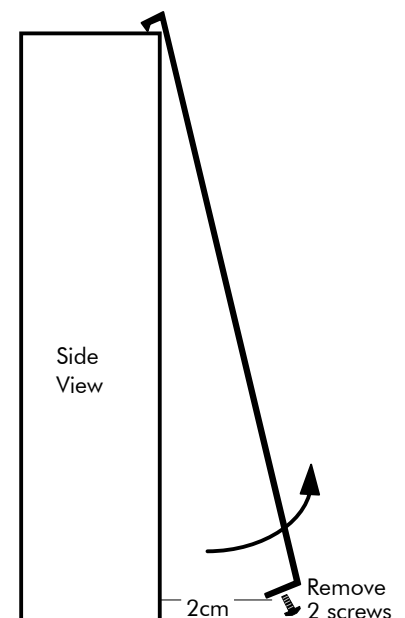

Product Dimensions

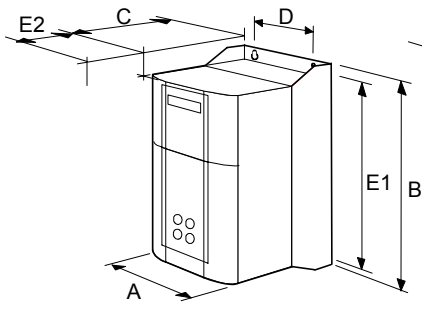

15A - 35A
Frame 1

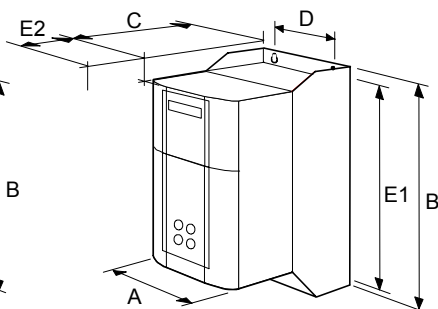

40A - 165A
Frame 2

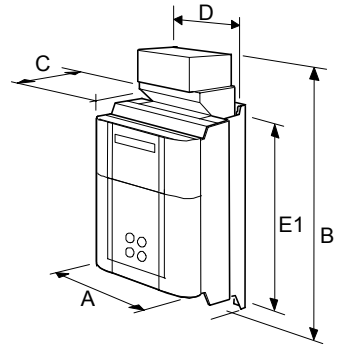

180A - 270A
Frame 3

Current Rating (A)	Weight in Kg (lbs)	Overall Dimensions			Fixing Centres	
		A	B	C	D	E1
15 - 35	6.4 (14)	200 (7.9)	375 (14.8)	220 (8.7)	140 (5.5)	360 (14.2)
40 - 165	10.5 (23)	200 (7.9)	434 (17.1)	292 (11.5)	140 (5.5)	418 (16.5)
180	20 (44)	250 (9.8)	485 (19.1)	180 (7.1)	200 (7.9)	400 (15.7)
270	20 (44)	300 (11.8)	500 (19.7)	210 (8.3)	200 (7.9)	400 (15.7)

Dimensions are in millimetres (inches)
Refer to the Installation Drawings

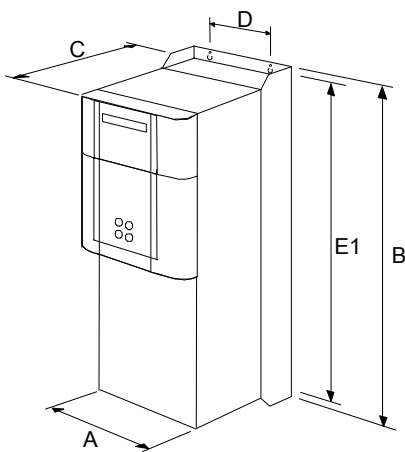

380A - 830A
Frame 4
(vent kit assemblies not shown)

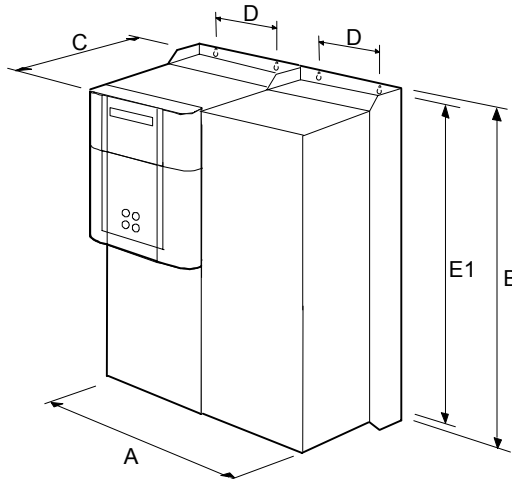

1580A
Frame 5
(vent kit assemblies not shown)

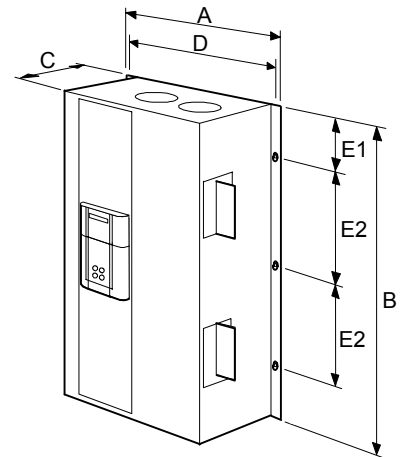

1200A - 2700A
Frame H

Current Rating (A)	Weight Kg (lbs)	Overall Dimensions			Fixing Centres		
		A	B	C	D	E1	E2
380	32 (71)	253 (10.0)	700 (27.6)	358 (14.2)	150 (5.9)	680 (26.8)	-
500	32 (71)	253 (10.0)	700 (27.6)	358 (14.2)	150 (5.9)	680 (26.8)	-
725	44 (97)	253 (10.0)	700 (27.6)	358 (14.2)	150 (5.9)	680 (26.8)	-
830	44 (97)	253 (10.0)	700 (27.6)	358 (14.2)	150 (5.9)	680 (26.8)	-
1580	90 (200)	506 (20.0)	700 (27.6)	358 (14.2)	150 (5.9)	680 (26.8)	-
1200 - 2700	See below *	850 (33.5)	1406 (55.3)	417 (16.4)	810 (31.9)	78 (3.1)	4 x 400 (15.7)
1200 - 2700	See below *	850 (33.5)	956 (37.6)	417 (16.4)	810 (31.9)	78 (3.1)	3 x 400 (15.7)

*590+ drive weighs 270Kg (595.4 lbs) without packaging and fan assembly
591+ drive weighs 160kg (352.8 lbs) without packaging and fan assembly
Fan weighs 18.5Kg (40.8 lbs)

Dimensions are in millimetres (inches)
Refer to the Installation Drawings

3-4 Installing the Converter

Mounting the Converter

General installation details are given below for mounting the Converter, however, if you are installing the unit with an EMC filter refer to “External AC Supply EMC Filter Installation”, page 3-25.

Mount the unit vertically on a solid, flat, vertical surface. It is mounted using bolts or screws into four fixing points (keyhole slots). The design allows the use of 100mm grid fixing.

It must be mounted inside a suitable cubicle. To comply with the European safety standards VDE 0160 (1994)/EN50178 (1998), the cubicle must require a tool for opening.

Note: *Holes for the mounting bolts or screws must be placed accurately.*

Cover any units already mounted to the panel while drilling mounting holes to protect them from stray metal filings.

General Mounting Hints

Insert the mounting studs from the rear of the panel. Attach lock washers and nuts part way on to the lower mounting studs; these will help to keep the drive in place when mounting.

Caution

Use proper lifting techniques when lifting and moving.

Lift the drive and engage the bottom slots safely on to the studs between the panel and lock washers/nuts you have just fitted. Engage the top slots with the remaining mounting studs and finger tighten the drive to the panel with lock washers and nuts. Finally, use the socket wrench to tighten all nuts securely.

Check the drive and its housing for packing material, mounting debris, or any other material that could damage and/or restrict the operation of the equipment.

Recommended Tools

Socket wrench	With a 6 Inch extension
Deep sockets	M10, M13, M17, 7/16", 1/2"
Screwdrivers	Phillips No.2, flat blade - 0.5 x 3.0mm, 0.8 x 4.0mm
Wire cutters	Small

Ventilation and Cooling Requirements

Refer to Chapter 11: “Technical Specifications” - Cooling.

The Converter gives off heat in normal operation and must therefore be mounted to allow the free flow of air through the air entries and exits. Maintain the minimum air clearances given on the drawings to ensure that heat generated by other adjacent equipment is not transmitted to the Converter, be aware that other equipment may have its own clearance requirements. When mounting two or more 590+’s together, these clearances are cumulative.

Ensure that the mounting surface is normally cool.

AC Line Choke

We recommend that you always use the specified ac line choke with the Converter to provide a known supply impedance for effective operation of the thyristor transient suppression circuits. At least 1% line impedance should be provided in the supply side of the converter.

Refer to Chapter 11: “Technical Specifications” - AC Line Choke for selection details.

Installing the Fan (Frame H)

Refer to Chapter 11: “Technical Specifications” - Cooling for fan ratings

The fan unit supplied should be installed on the cubicle, with or without ducting (refer to the Installation Drawing). The drive is force-cooled using the fan units supplied with the drive. As a general rule allow at least 150mm (6 inches) of clear space above and below the drive for free air flow. We suggest the cubicle has an air inlet at the base of the cubicle equivalent to 4ft², variable depending upon the filter type used, to allow the maximum throughput of air.

The fan assembly provided is permanently wired as shown below.

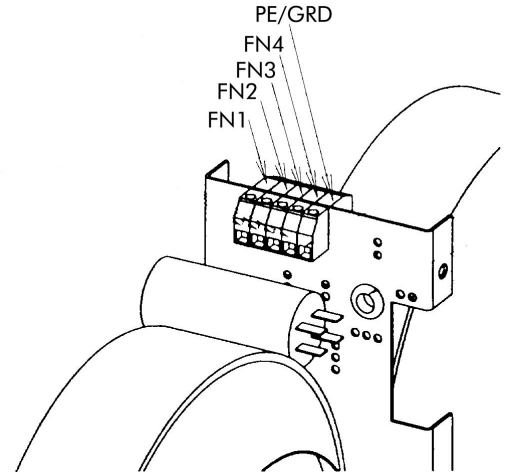
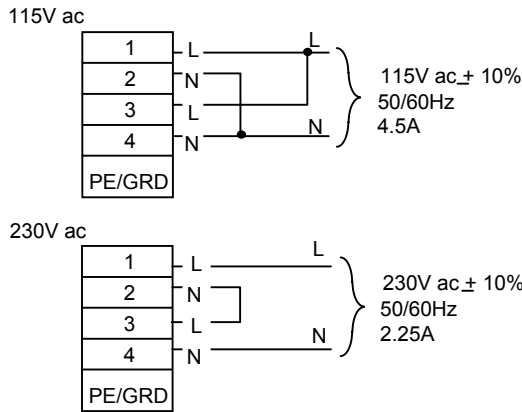
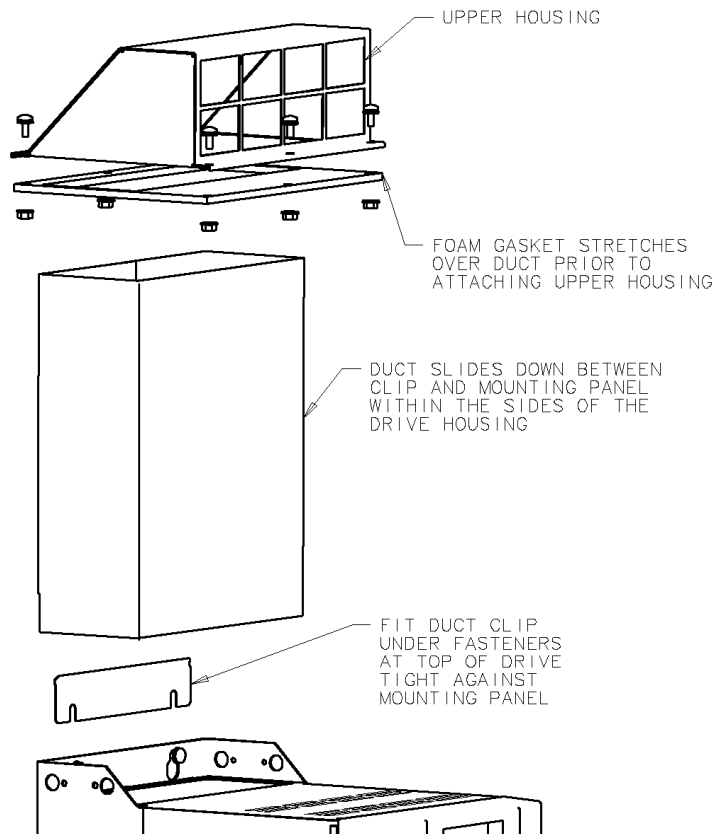

Figure 3-2 Fan Wiring Diagram

Installing the External Vent Kit (Frames 4 & 5)

Refer also to Figure 3-14 page 3-35 and Figure 3-16 page 3-37.



3-6 Installing the Converter

Electrical Installation

IMPORTANT: Please read the Safety Information on page Cont. 3 & 4 before proceeding.

WARNING!
Ensure that all wiring is electrically isolated and cannot be made "live" unintentionally by other personnel.

Note: Refer to Chapter 11: "Technical Specifications" for additional Cabling Requirements and Terminal Block Wire Sizes.

Cables are considered to be electrically *sensitive*, *clean* or *noisy*. You should already have planned your cable routes with respect to segregating these cables for EMC compliance. If not, refer to Chapter 12: "Certification for the Converter".

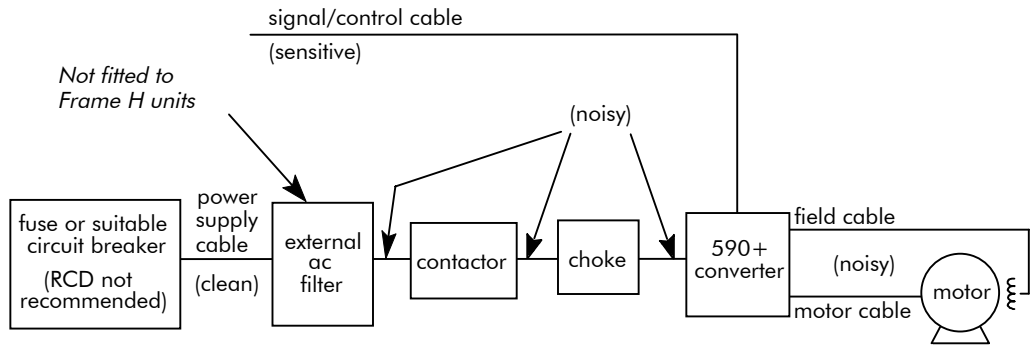

Figure 3-3 Cabling Requirements

If the controller is to be operating in a regenerating mode for extended periods acting as a load generator for another machine, it is advisable to fit additional protection in the armature circuit. A dc fuse or high speed circuit breaker will provide this protection. If in doubt, contact Eurotherm Drives.

Cable Gland Requirements

Use a metal gland to connect to the cubicle backplate, near the VSD (variable speed drive). It must be capable of securing a 360 degree screened connection to give EMC compliance. A 360 degree screened connection can be achieved as shown.

We suggest a rubber grommet should be fitted on holes where a cable gland is not used.

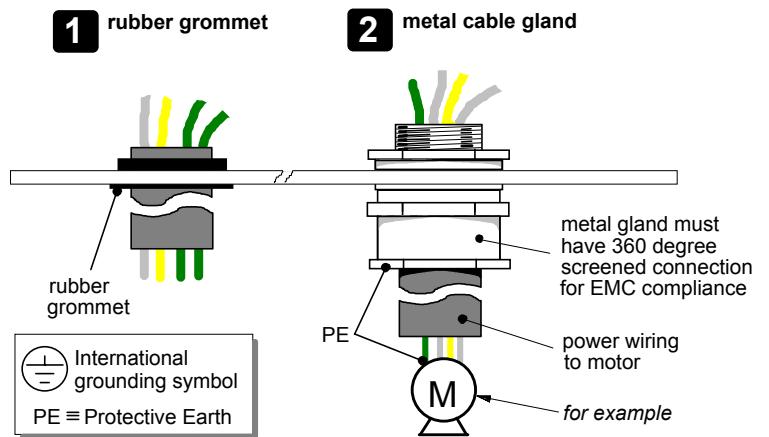

Figure 3-4 Cable and Screen Fixings

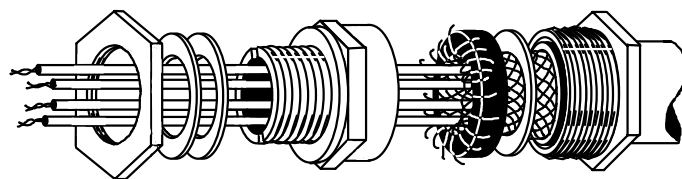

Figure 3-5 360 Degree Screened Connection

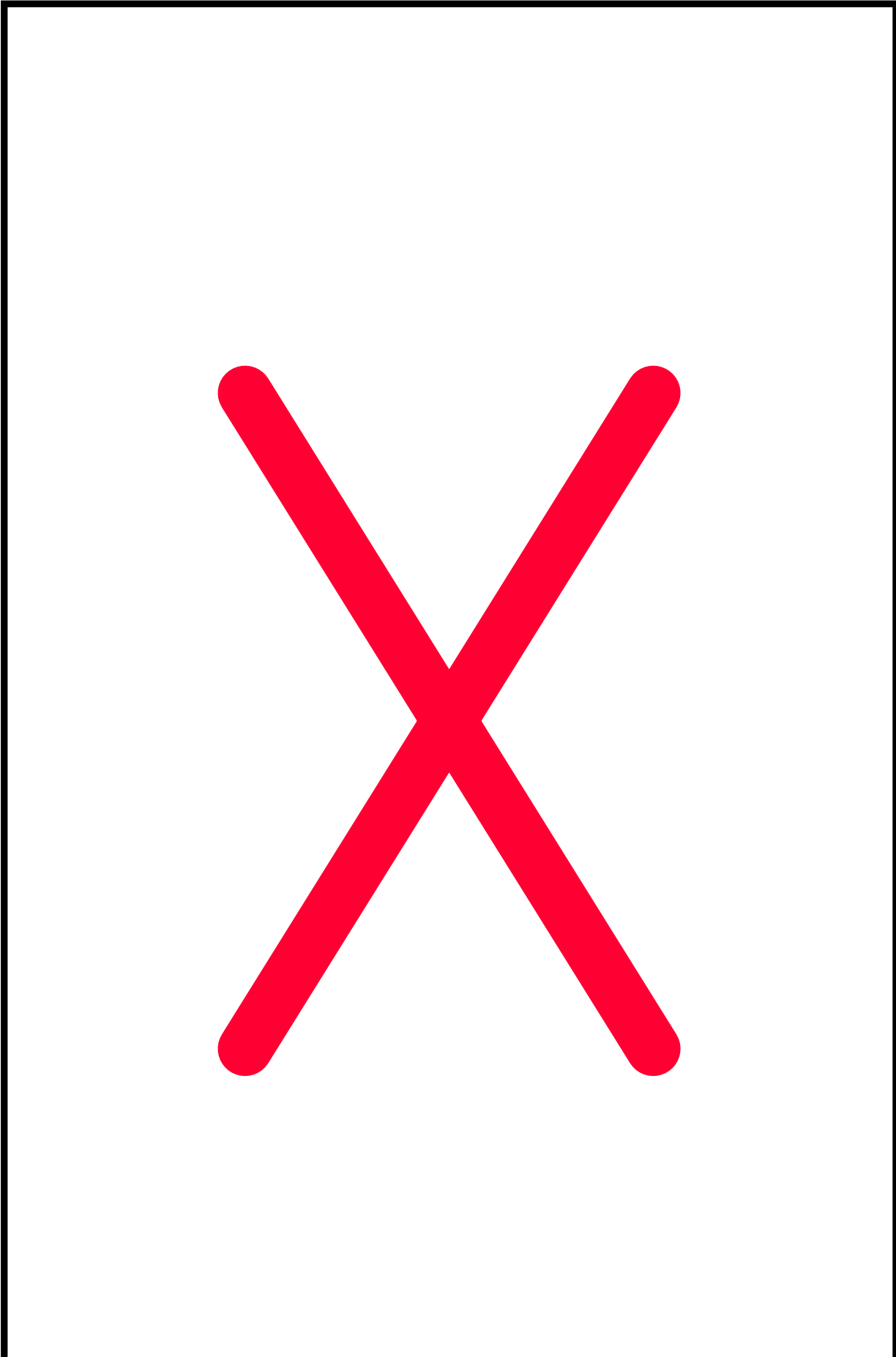

Figure 3-6 Minimum Connection Requirements (‘general purpose’ configuration)

3-8 Installing the Converter

Minimum Connection Requirements (Frames 1, 2, 3, 4 & 5)

Note: Because of the complexity of showing all possible configurations, this Chapter deals only with a 'general purpose' operation as a basic speed controller. Special wiring options usually form part of a customer-specific system and connection details will be provided separately.

The circuit diagram over the page uses bold lines to show the minimum connection requirements for operating the Converter. These connection details are highlighted 1 to 9 in the following text with the symbol opposite. The remaining connection details are not necessary for a "quick start-up".

MINIMUM
CONNECTION
REQUIREMENT

The Converter is using the default Armature Voltage feedback when following the 'minimum connection' instructions.

Caution

Make sure all wiring connections meet or exceed applicable local and National Electrical Codes. Be sure to fit branch circuit and motor overload protection.

IMPORTANT: Indicator lamps, annunciators, etc., for "Drive On" condition should be switched by an auxiliary contactor of the main contactor, not by the controller auxiliary relay.

To avoid damaging the drive NEVER carry out high voltage resistance or dielectric strength tests without first completely disconnecting the drive from the circuit being tested.

- Power cables must have a minimum rating of 1.1 x full load current. (1.25 x FLC when required to comply with UL requirements).
- All incoming main AC power supply connections must be protected with high speed fuses. Refer to Chapter 11: "Technical Specifications" for fuse information.
- The External AC Supply EMC Filter must only be fitted on the mains side of the contactor.

Important Connections

The following connections must be made:

- Terminal C5 must be connected to C9 for the drive to run.
- Terminals TH1 and TH2 must be linked if a thermostat is not fitted.
- Terminals C1 and C2 must be linked if an External Trip interlock is not required.

Protective Earth Connections (PE) - (Frames 1, 2, 3, 4 & 5)

1 MINIMUM CONNECTION REQUIREMENT

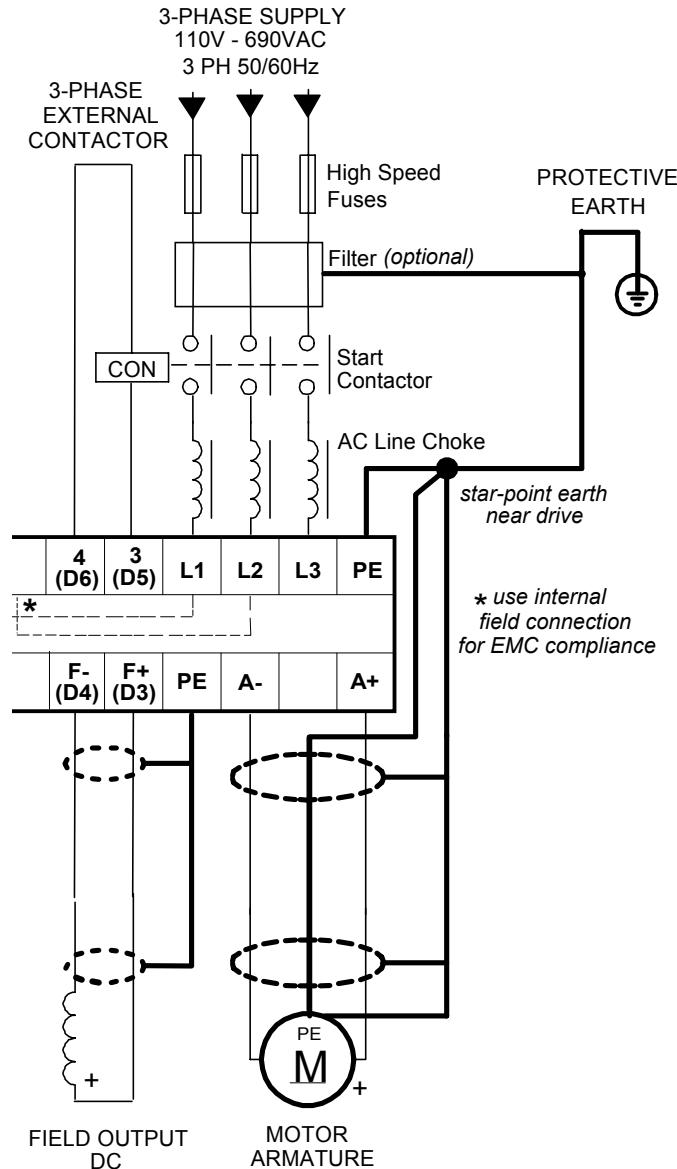

IMPORTANT: The drive and filter (if fitted) must be **permanently earthed**. Each conductor used for permanent earthing must *individually* meet the requirements for a protective earth conductor.

For installations to EN 60204 in Europe:

- For permanent earthing, the converter requires either two individual incoming protective earth conductors (<math><10\text{mm}^2</math> cross-section), or one conductor (>math>\geq 10\text{mm}^2</math> cross-section) connected to an independent protective earth/ground point near the drive.
- Run the motor protective earth/ground connection in parallel with the motor supply conductors, ideally in the same conduit/screen/armour, and connect to an independent protective earth/ground point near the drive.
- Connect the drive to the independent earth/ground point.

Refer to Chapter 12: “Certification for the Converter” - Screening & Earthing (cubicle mounted, Class B).

Protect the incoming mains supply, detailed in Chapter 11: “Technical Specifications” - Power Details, using a suitable fuse or circuit breaker (a circuit breaker, e.g. RCD, ELCB, GFCI, is not recommended, refer to “Earth Fault Monitoring Systems”, page 3-30.)

3-10 Installing the Converter

Power Wiring Connections (Frames 1, 2, 3, 4 & 5)

WARNING!

Power terminals carry electrical voltage which can be lethal. Never work on any control equipment or motors without first removing all power supplies from the equipment.

3-Phase External Contactor (3, 4)

A 3-phase external contactor should be connected in the main ac power supply connections with a rating suitable (AC1) for the controller concerned.

The contactor does not switch current and is primarily for disconnection and sequencing of the power bridge. The main contactor must be energised directly from the controller by connecting the coil to terminals 3 (Line) and 4 (Neutral). No additional series contacts or switches are permitted since they will interfere with the sequencing of the controller and cause unreliability and possible failure.

A relay jumper (CONN1) is provided on the power board enabling terminals 3 & 4 to be powered (auxiliary supply), or to be volt-free (for customers own contactor supply). Refer to Chapter 13: "AH466701U001, U002, U003 (Frames 4 & 5)".

Note: If the 3-phase contactor has a coil with an inrush greater than 3A, a slave relay must be used to drive the contactor coil. The contactor and slave relay (if required) must have coil voltages compatible with the controller auxiliary supply voltage.

2 MINIMUM CONNECTION REQUIREMENT

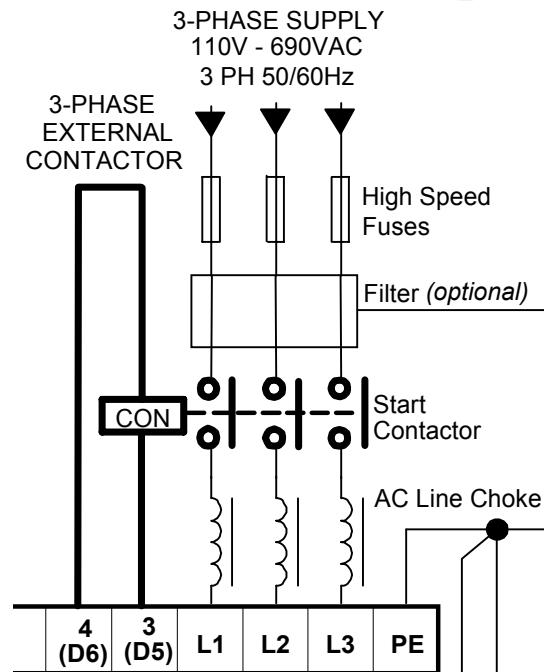

3-Phase Supply, AC Line Choke (L1, L2, L3)

The main ac power is connected to busbar terminals L1, L2 and L3, there is no specific phase connection to these three terminals as the controller is phase rotation independent. The connections must be made via the circuit breaker and the ac line choke.

IMPORTANT: If a motor becomes completely short-circuited, the current trip (OVER I TRIP) will not protect the Converter. Always provide high-speed thyristor fusing to protect the thyristor stack in the case of direct output short circuits.

Fit a 3-phase ac line choke in series with the incoming main 3-phase ac power supply. (Eurotherm Drives stock a series of chokes suitable for this duty, mechanically designed to connect directly to the controller ac supply terminals.) The choke should be connected between the controller and Type 2 RCD for optimum protection and safety.

Note: You must provide branch circuit protection:
 $AC\ current = 0.83 \times DC\ Armature\ Current$

3 MINIMUM CONNECTION REQUIREMENT

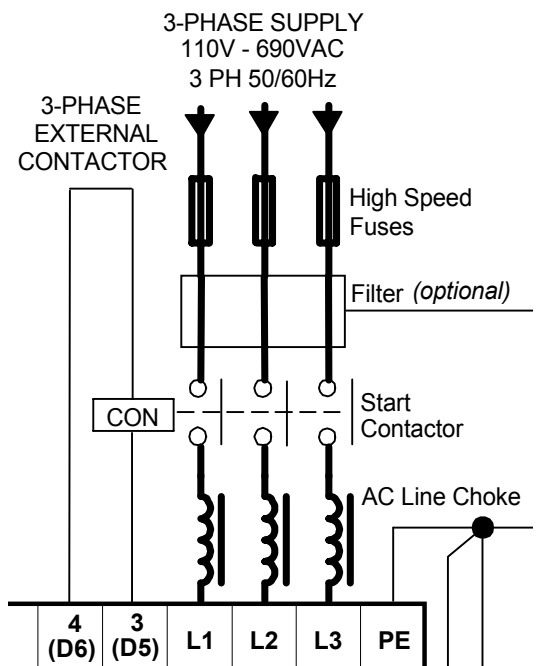

Auxiliary Supply (L, N)

Connect the control supply (single phase 50/60Hz) to terminals L and N with suitable external fuse protection.

The steady state current absorbed by the controller is nominal, the external fuse is determined chiefly by considering the contactor holding VA and the controller cooling fans. Refer to Chapter 11: "Technical Specifications" - Cooling Fans



4 MINIMUM CONNECTION REQUIREMENT

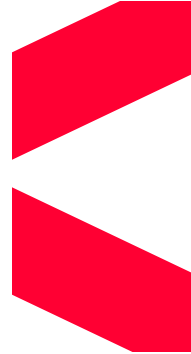

Field (F+, F-)

Connect the motor field (-) to terminal F- and field (+) to terminal F+.

Note: *If the motor has no field connections, is a permanent magnet motor, or if the field is derived externally, you must inhibit the FIELD ENABLE parameter.*

5 MINIMUM CONNECTION REQUIREMENT

Motor Armature (A+, A-)

The motor armature is connected to terminals A+ and A-.

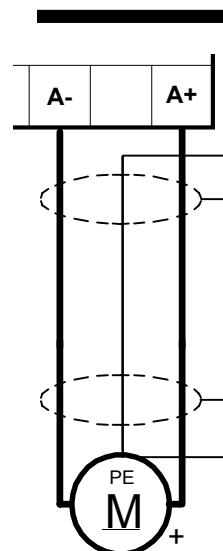

6 MINIMUM CONNECTION REQUIREMENT

MOTOR ARMATURE

3-12 Installing the Converter

External AC Field (FL1, FL2)

(Not available on Frame 1 units)

If an external field supply is required to the controller for application reasons, connect this supply to terminals FL1 and FL2. The magnitude of this voltage is determined by the desired field voltage. The supply must be protected externally with suitable fuses. Always derive the supply from the Red and Yellow phases of the main power supply, with the Red phase connected to terminal FL1 and the Yellow phase to terminal FL2.

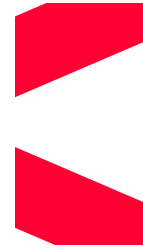

Note: You must provide branch circuit and overload protection. Use internal field connection for EMC compliance.

IMPORTANT: It is important that connection of the controller and the external field supply is consistent when using an externally supplied field regulator. The supply must be derived from L1 (Red) and L2 (Yellow) phases directly or indirectly through a single-phase transformer. L1 must be connected to FL1, and L2 connected to FL2.

To change the controller from an internal to an external field type refer to Motor Field Connections.

Thermistor (TH1, TH2)

Terminals TH1 and TH2 must be linked if sensors are not fitted. The motor temperature alarm (THERMOSTAT) cannot be inhibited in software.



We recommend that you protect the dc motor against overtemperature by the use of temperature sensitive resistors or switches in the field and interpole windings of the machine.

When the motor is fitted with over-temperature sensing devices, such as thermostats or PTC thermistors, these should be connected (in series) between terminals TH1 and TH2.

- Thermistors must have a combined working resistance of 750Ω or less, rising to $4k\Omega$ at over-temperature. These thermistors are classified by IEC34-II as Mark A.
- Temperature switches must be normally closed, and open at rated temperature.

The controller's thermistor alarm will activate at $3k\Omega$.

The over temperature alarm is latched in software and must be reset by re-starting the Converter.

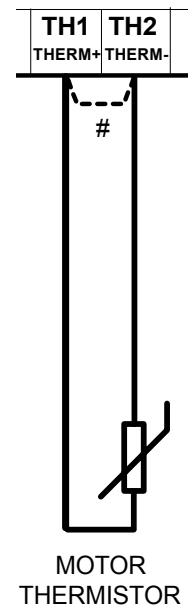

Control Wiring Connections (Frames 1, 2, 3, 4 & 5)

Note: Refer to Chapter 11: "Technical Specifications" for Control Terminal information.

- Use screened control cables to comply with EMC requirements.
- Control wiring must have a minimum cross-section area of 0.75mm² (18AWG).
- Feed the control cables into the Converter and connect to the control terminals. Refer to the connection label on the inside of the terminal cover. Close the terminal cover.

IMPORTANT: All connections made to terminal blocks A, B and C must be isolated signal voltages. If in doubt about the connection of the DC motor to the controller check with Eurotherm Drives.

Setpoint Ramp Input (A4, A6, B3, B4 & Current Limit)

For normal operation the speed demand signal is connected to the "Setpoint Ramp Input", terminal A4 (Analog Input 3). This input is scaled so that:

- +10V input = maximum forward speed demand (+100%)
- 10V input = maximum reverse speed demand(-100%)

The speed demand signal can be generated by connecting the two ends of an external 10K potentiometer to the +10V reference terminal B3 and -10V reference terminal B4, the wiper of the potentiometer being connected to the "Setpoint Ramp Input" as the speed reference.

The main current limit is adjustable by means of the MAIN CURR. LIMIT parameter [Tag No. 15]:

- For normal operation of the main current limit, Terminal A6 should be connected to the +10V reference, Terminal B3. The CURR. LIMIT/SCALER parameter should be set to 200%. This allows the MAIN CURR. LIMIT parameter to adjust the current limit between 0 and 200% full load current.
- If external control of the main current limit is required, a 10K potentiometer connected between Terminal B3 (+10V Ref) and Terminal B1(0V), with the wiper connected to Terminal A6 (Analog I/P5) gives 0 to 200% of full load current provided that the MAIN CURR. LIMIT and CUR. LIMIT/SCALER parameters are set to 200%.

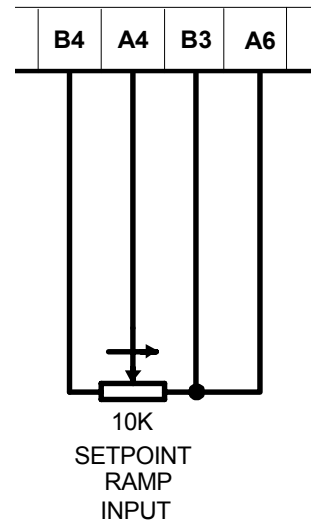

Signal 0V (A1)

This is the common reference point for all analog signals used in the drive.

For non-reversing applications and 2 quadrant controller (591+), the speed demand only needs to operate between 0V and +10V, the anti-clockwise end of the potentiometer should then be connected to Terminal A1 (0V).

Speed Setpoint No. 1 (A2)

Terminal A2 (Analog Input 1) is a direct speed demand by-passing the "Setpoint Ramp Generator", and should be used if direct control is required.

Speed Setpoint No. 2 / Current Demand (A3)

Terminal A3 (Analog Input 2) is a dual function terminal (either "Speed Setpoint No. 2" or "Current Demand") as selected by mode switch control "Current Demand Isolate", Terminal C8. As a speed setpoint, it can be used in the same way as Terminal A2.

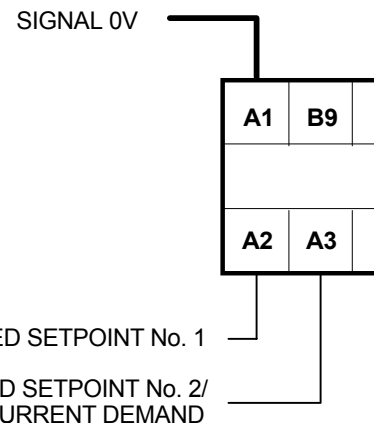

Note: If more than one speed setpoint is used, they are additive.

3-14 Installing the Converter

Enable, Start/Run, Emergency Stop Relay (B8, B9, C3, C5, C9)

Terminal C5 (Enable) must be connected to Terminal C9 (+24V) in order to allow the drive to run.

9 MINIMUM CONNECTION REQUIREMENT

Start

The basic run/start sequence of the controller is provided by Terminal C3 (Start/Run), although other safeguards for extra protection are provided by Terminal B8 (Program Stop) and Terminal B9 (Coast Stop).

Assuming that the Program Stop and Coast Stop terminals are held TRUE, then a single contact connected between Terminal C9 (+24V) and Terminal C3 (Start/Run) when closed will cause the controller to energise the Main Contactor and, provided Terminal C5 (Enable) is also TRUE, will run the associated DC motor.

When the single contact to Terminal C3 (Start/Run) is opened, the controller will decelerate the motor to zero speed at a rate determined by the STOP TIME parameter's value and the MAIN CURR. LIMIT value. Refer to Chapter 6: "Application Programming" - STOP RATES for further information.

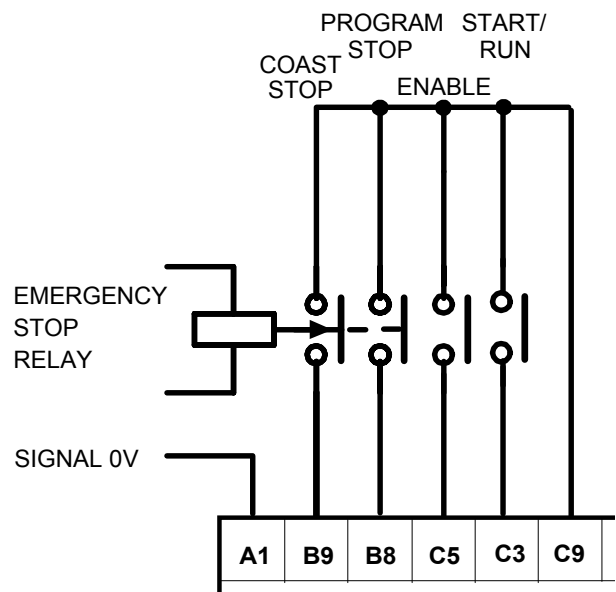

Note: The Enable input is useful to inhibit the drive without opening the main contactor, however, it is not a safe mode of operation as the drive dc output is only reduced to zero. If the equipment controlled by the drive is to be serviced, then this method should be avoided and the drive disabled and isolated.

A regenerative drive can be stopped using a Normal Stop, a Program Stop, or an Emergency Stop, as described below. However, a non-regenerative drive can only be made to stop faster than friction and loading will allow by Dynamic Braking.

Normal Stop

If the +24V is removed from Terminal C3 whilst the drive is controlling the motor under "Run" conditions, the controller will cause the motor to decelerate rapidly to rest at a rate determined by STOP LIMIT, STOP TIME and CURR. LIMIT.

Program Stop

If the +24V is removed from Terminal B8 whilst the drive is controlling the motor under "Run" conditions, the controller will cause the motor to decelerate rapidly to rest at a rate determined by PROG STOP I LIM, PROG STOP LIMIT and PROG STOP TIME. If the signal is re-applied to Terminal B8, the motor remains stationary until a new Start command is applied to Terminal C3 (Start/Run).

Emergency Stop

Additional terminals, Terminal B8 (Program Stop) and Terminal B9 (Coast Stop), provide extra facilities for the control of the regenerative controller:

- Terminal B9 (Coast Stop) must be held at +24V to allow closure of the main contactor, the connection provides the power supply to allow the electronics to operate the auxiliary relay and hence the main contactor.

Connect Terminal B9 (Coast Stop) to Terminal C9 (+24V) via a normally open delay-on-de-energisation contact of an "emergency" stop relay. The emergency stop relay should not be part of the normal sequencing of the system, which is implemented via the Start contacts, but

is a relay which can be operated in exceptional circumstances where human safety is of paramount importance.

- Terminal B8 (Program Stop) provides a facility for regenerative braking on a 4 Quadrant drive (590+).

Zero Speed, Drive Healthy, Drive Ready (B5, B6, B7)

These digital output terminals provide a +24V dc output signal under certain conditions. This allows for the connection of relays which, in conjunction with the Enable, Start/Run and Emergency Stop relay, can be used to enhance the safe starting and stopping of the controller.

These are configurable outputs and can be used as required in the control system design, i.e. cubicle door lamps, connection to a suitable PLC.

(The diagram shows a simple default configuration).

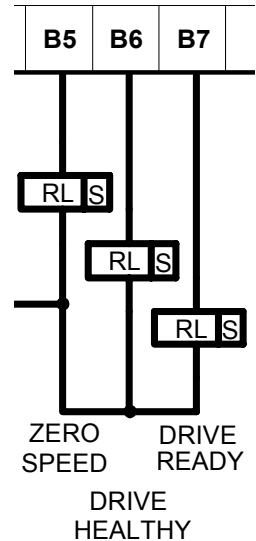

Analog Tachometer (G1, G2, G3, G4)

Refer to Chapter 13: “Standard and Optional Equipment” - Optional Equipment for further information.

An Analog Tachometer is connected to the Converter using a screened twisted pair cable throughout its entire length to provide speed feedback via the Tacho Calibration Option Board. This provides facility for an AC or DC tachometer. The screen is grounded or earthed only at the drive end, any other grounding arrangement may cause problems.

Terminals G1 & G2 are for AC tacho connections.

Terminals G3 & G4 are for DC tacho connections.

Note: The speed loop is set-up for an analog tacho by the SPEED FBK SELECT parameter in the SPEED LOOP function block. Select ANALOG TACH for this parameter.

If an AC tachogenerator is used the output is rectified to produce the dc feedback to the speed loop. Consequently, the controller can only be used with a positive setpoint.

Refer to Chapter 4: “Operating the Converter” for set-up information.

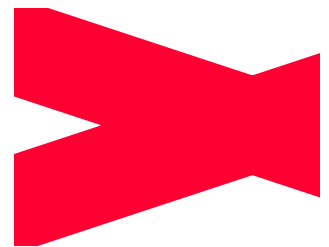

External Trip (C1, C2)

Terminals C1 and C2 must be linked if an External Trip interlock is not required.

This input terminal provides an external trip facility to any normally-closed trip switch, e.g. for vent fan overload protection.

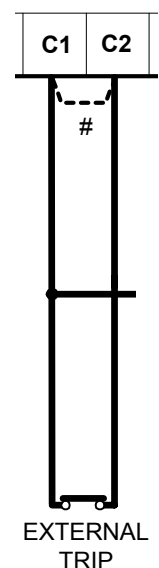

3-16 Installing the Converter

Microtach (F1, C1, C9)

Refer to Chapter 13: “Standard and Optional Equipment” - Optional Equipment for further information.

The Eurotherm Drives MICROTACH is available in two versions:

- 5701 Plastic Fibre Microtach
- 5901 Glass Fibre Microtach

A Microtach can be connected to provide speed feedback via the Microtach Option Board, using the international standard “ST” fibre optic system.

F1 is the fibre optic receiver input socket. Terminals C9 (+24V dc) and C1 (0V) are used to provide the supply and return respectively.

Note: *The speed loop is set-up for the Microtach by the SPEED FBK SELECT parameter in the SPEED LOOP function block. Select ENCODER for this parameter.*

The maximum Microtach frequency is 50kHz, thus with a standard 1000 lines per revolution Microtach the motor speed cannot exceed 3000 rpm.

For specification and connection information refer to Eurotherm Drives or the appropriate Technical Manual.

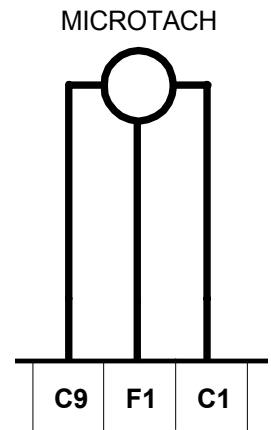

Wire-Ended Encoder (E1, E2, E3, E4, E5, E6)

Refer to Chapter 13: “Standard and Optional Equipment” - Optional Equipment for further information.

- The wire-ended encoder is connected to the Converter using a screened cable throughout its entire length to provide speed feedback.

Terminals E1 (0V) and E2 (+24V dc) are the return and supply respectively.

Note: *The speed loop is set-up for the Encoder by the SPEED FBK SELECT parameter in the SPEED LOOP function block. Select ENCODER for this parameter.*

The maximum allowable encoder frequency is 100kHz, thus with a standard 1000 lines per revolution encoder the motor speed cannot exceed 6000 rpm.

For specification and connection information refer to Eurotherm Drives or the appropriate Technical Manual.

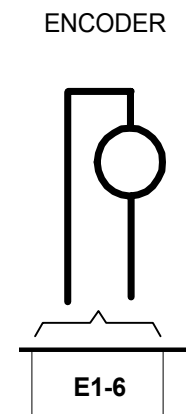

Technology Box Option

The option, when fitted to each unit, allows converters to be linked together to form a network.

Refer to the appropriate Technical Manual supplied with the Technology Box.

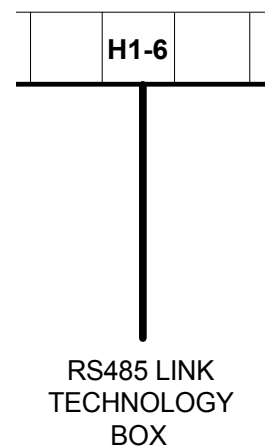

Minimum Connection Requirements (Frame H)

Note: Because of the complexity of showing all possible configurations, this Chapter deals only with a 'general purpose' operation as a basic speed controller. Special wiring options usually form part of a customer-specific system and connection details will be provided separately.

MINIMUM
CONNECTION
REQUIREMENT

The minimum connection requirements for operating the Converter are highlighted in the following text with the symbol opposite.

The Converter is using the default Armature Voltage feedback when following the 'minimum connections' instructions.

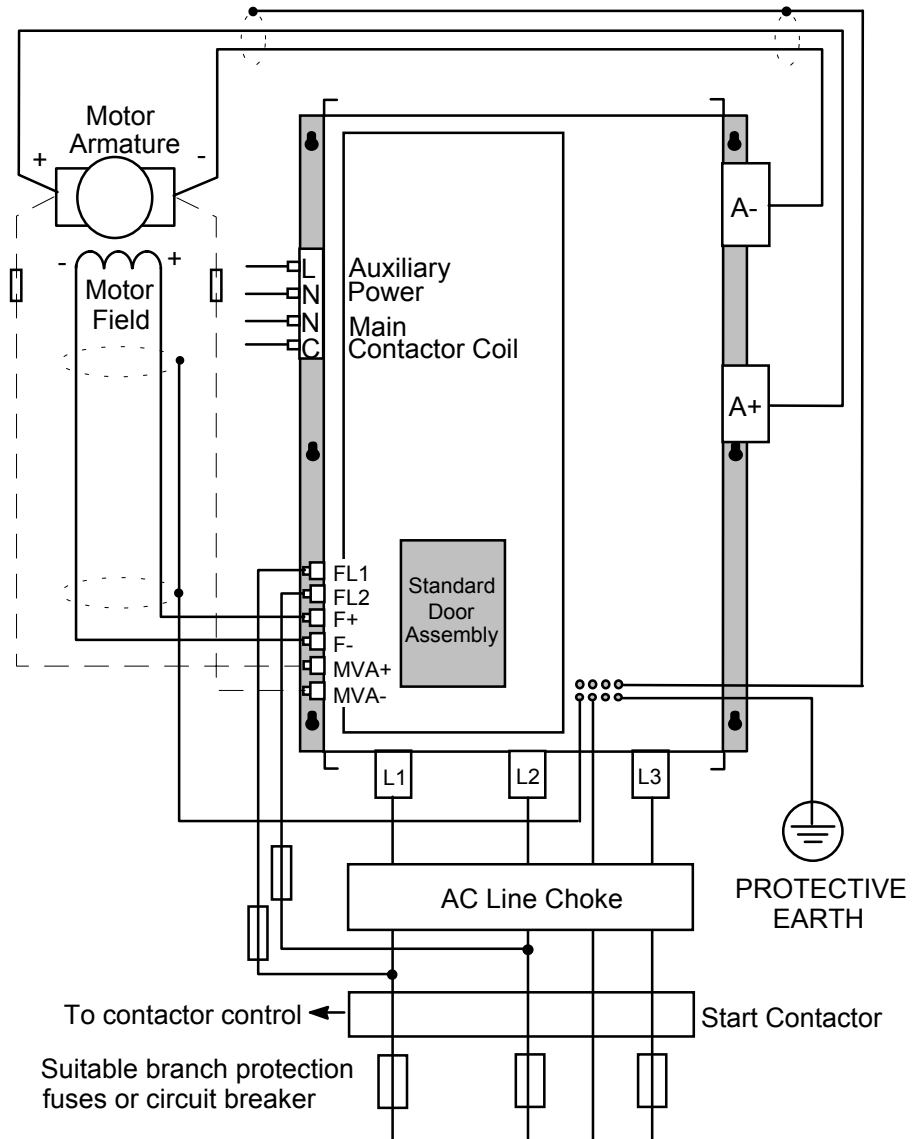

Figure 3-7 Minimum Connection Requirements ('general purpose' configuration)

IMPORTANT: Indicator lamps, annunciators, etc., for "Drive On" condition should be switched by an auxiliary contactor of the main contactor, not by the controller auxiliary relay.

To avoid damaging the drive NEVER carry out high voltage resistance or dielectric strength tests without first completely disconnecting the drive from the circuit being tested.

- Power connections must have a minimum rating of 1.1 x full load current. (1.25 x FLC when required to comply with UL requirements).
- All incoming main AC power supply connections must be protected with high speed semiconductor fuses. Refer to Chapter 11: "Technical Specifications" for fuse information.
- The External AC Supply EMC Filter must only be fitted on the mains side of the contactor.

3-18 Installing the Converter

Protective Earth Connections (PE) - (Frame H)

IMPORTANT: The Converter must be **permanently earthed**. Each conductor used for permanent earthing (refer to the Figure in Chapter 2 - Component Identification) must *individually* meet the requirements for a protective earth conductor (refer to Chapter 11: "Technical Specifications" - Earthing/Safety Details).

1 MINIMUM CONNECTION REQUIREMENT

For installations to EN 60204 in Europe:

- For permanent earthing, the converter requires one conductor ($\geq 10\text{mm}^2$ - 6AWG) connected to an independent protective earth/ground point near the drive.
- Run the motor protective earth/ground connection in parallel with the motor supply conductors, ideally in the same conduit/screen/armour, and connect to an independent protective earth/ground point near the drive.
- Connect the drive to the independent earth/ground point.

Refer to Chapter 12: "Certification for the Converter" - Screening & Earthing (cubicle mounted, Class B).

Refer to the Figure in Chapter 2 - Component Identification and to Chapter 11: "Technical Specifications" - External Fuses and Recommended Wire Sizes.

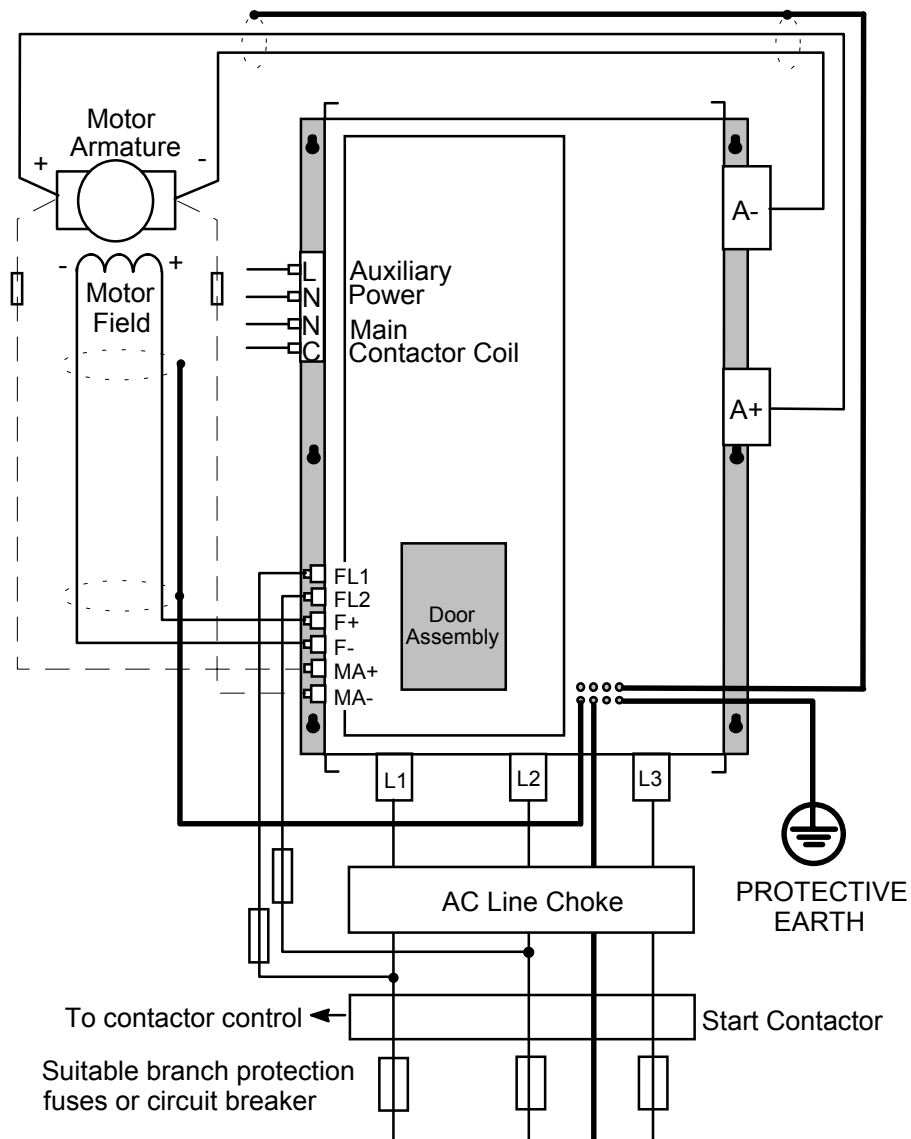

Power Wiring Connections (Frame H)

WARNING!

The power terminals carry electrical voltage which can be lethal. Never work on any control equipment or motors without first removing all power supplies from the equipment and allow to discharge for 3 minutes.

3-Phase Contactor (C, N)

A 3-phase contactor should be connected in the main ac power supply connections with a rating suitable (AC1) for the controller concerned. The contactor does not switch current and is primarily for disconnection and sequencing of the power bridge. The main contactor must be energised directly from the controller by connecting the coil to terminals C (Line) and N (Neutral). No additional series contacts or switches are permitted since they will interfere with the sequencing of the controller and cause unreliability and possible failure.

2 MINIMUM CONNECTION REQUIREMENT

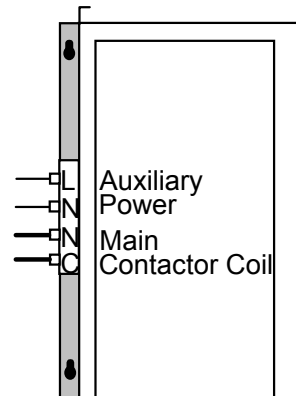

Note: A slave relay must be used to drive the contactor coil. The contactor and slave relay must have coil voltages compatible with the controller auxiliary supply voltage.

A dc contactor can be used but the sequencing must be adjusted to accommodate its use, an auxiliary normally open volt-free contact of the contactor must be connected in series with the "enable" input C5 to disable the drive until after the contactor is closed.

3-Phase Supply, AC Line Choke (L1, L2, L3)

Refer to Figure 3-7 Minimum Connection Requirements ('general purpose' configuration)

The main ac power is connected to busbar terminals L1, L2 and L3, there is no specific phase connection to these three terminals as the controller is phase rotation independent. The connections must be made via the main contactor and the ac line choke.

3 MINIMUM CONNECTION REQUIREMENT

High speed, semi-conductor fuses are provided in the unit to protect the thyristor stack in case of direct output short circuits. You should provide suitable branch protection fuses to protect cabling.

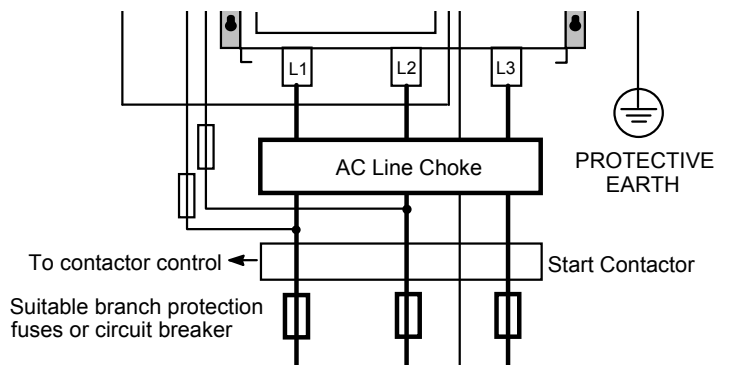

Fit a 3-phase ac line choke in series with the incoming main 3-phase ac power supply. (Eurotherm Drives

can provide suitable choke for this duty, mechanically designed to connect directly to the controller ac supply terminals.) The choke should be connected between the controller and the ac contactor for optimum protection and safety.

3-20 Installing the Converter

Auxiliary Supply (L, N)

Connect the auxiliary supply (single phase 50/60Hz) to terminals L (Line) and N (Neutral) with suitable external fuse protection. The steady state current absorbed by the controller is nominal, the external fuse is determined chiefly by considering the contactor holding VA and the controller cooling fans.

Note: The auxiliary supply must be connected directly to the incoming supply, no series sequencing switches or contacts are permitted without consultation with Eurotherm Drives.

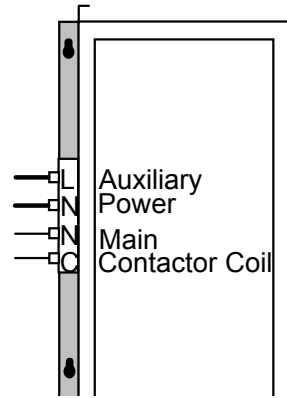

4 MINIMUM CONNECTION REQUIREMENT

Field (F-, F+)

Connect the motor field (-) to terminal F- and field (+) to terminal F+. If the motor has no field connections, is a permanent magnet motor, or if the field is derived externally, you must inhibit the FIELD ENABLE parameter. Refer also to "Fuse Rating and Recommended Wire Sizes", page 11-2.

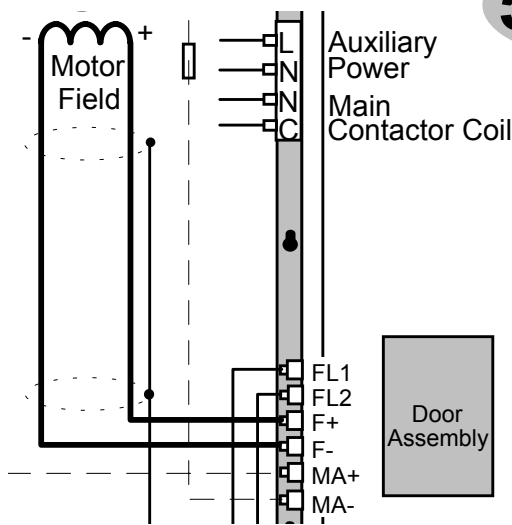

5 MINIMUM CONNECTION REQUIREMENT

Motor Armature (A+, A-)

The motor armature is connected to busbar terminals A+ and A-. If a DC contactor is used the poles should be interposed between the controller terminals and the motor terminals.

For EMC purposes we recommend that the maximum cable length does not exceed 1km.

When the controller is operating in a regenerating mode for extended periods acting as a load generator for another machine, it is advisable to fit additional protection in the armature circuit. A DC fuse or a high speed circuit breaker will provide this protection, if in doubt consult Eurotherm Drives.

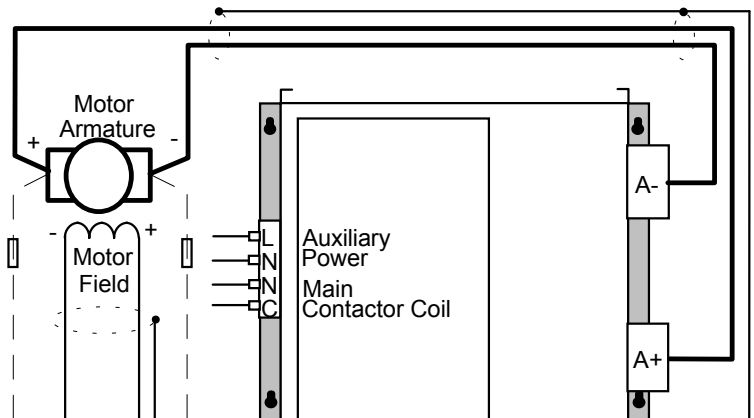

6 MINIMUM CONNECTION REQUIREMENT

7 MINIMUM CONNECTION REQUIREMENT

External AC Field (FL1, FL2)

An external field supply is required to the controller under all circumstances. Connect this

supply to terminals FL1 and FL2. The magnitude of this voltage is determined by the desired field voltage. The supply must be protected externally with suitable fuses. Always derive the supply from the Red and Yellow phases of the main power supply, with the Red phase connected to terminal FL1 and the Yellow phase connected to FL2.

IMPORTANT: It is important that connection of the controller and the external field supply is consistent when using an externally supplied field regulator. The supply must be derived from L1 (Red) and L2 (Yellow) phases directly or indirectly through a single-phase transformer. L1 must be connected to FL1, and L2 connected to FL2.

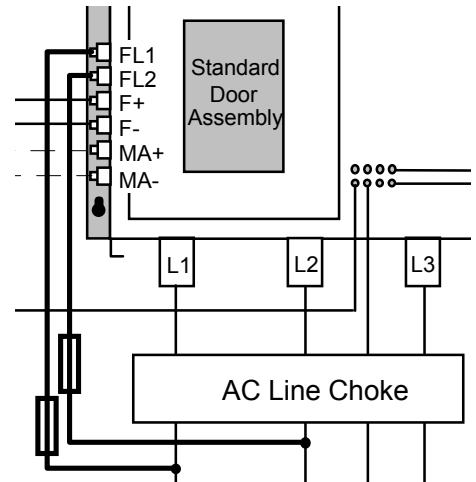

External Armature Volts (MA+, MA-)

External Armature Volts can be used where a more sensitive reading of terminal volts is required. When required the terminal MVA+ should be wired to the Motor A+ terminal and MVA- should be wired to Motor A- terminal via suitable fuses.

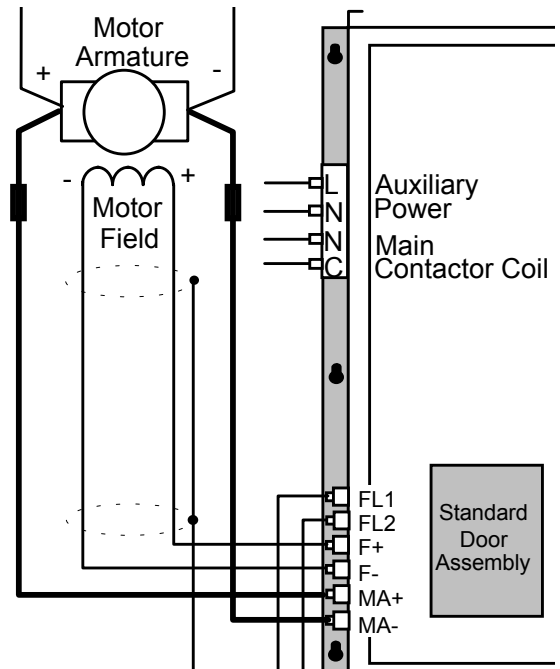

Control Wiring Connections (Frame H)

For all connection requirements, refer to “Control Wiring Connections (Frames 1, 2, 3, 4 & 5)”, page 3-13. Because all models use the same control board, these instructions are common.

3-22 Installing the Converter

Motor Field Connections

WARNING!
Isolate the drive before converting to internal/external supply.

The FIELD CONTROL function block controls the motor field. The FLD CTRL MODE parameter allows you to select either Voltage or Current Control mode.

- In Voltage Control mode, the RATIO OUT/IN parameter is used to scale the motor field output voltage as a percentage of the input supply voltage.
- In Current Control mode, the SETPOINT parameter is used to set an absolute motor field output current, expressed as a percentage of the calibrated field current (IF CAL).

Internal/External Supply (Frames 2, 3, 4 & 5)

Note: The Frame 1 unit uses only an internal motor field supply. The Frame H unit uses only an external motor field supply. For information about the following terminal/power boards refer to Chapter 11: "Technical Specifications" - Power Board Types, and Terminal Information (Power Board).

The internal motor field is more widely used, however, there is provision on the unit for an external motor field supply to be connected (perhaps for where the field voltage is greater than the input voltage and therefore not attainable, or where the motor field is switched separately for convenience).

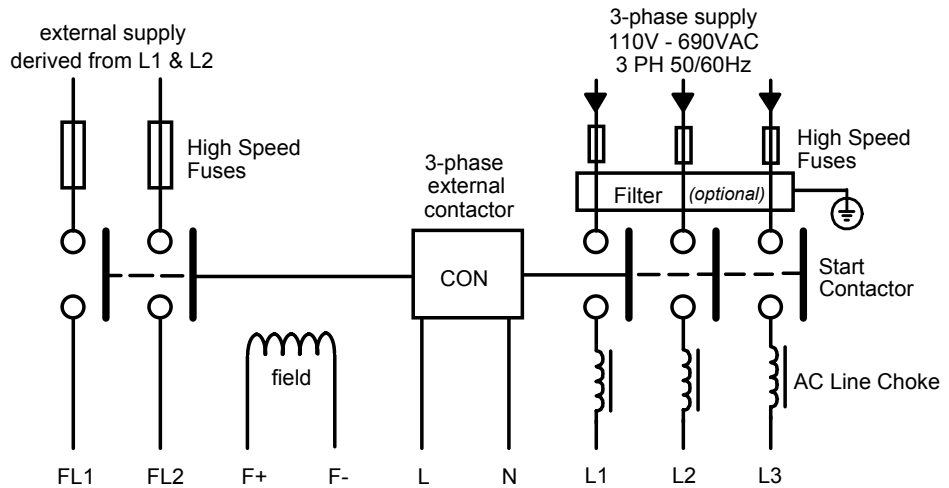
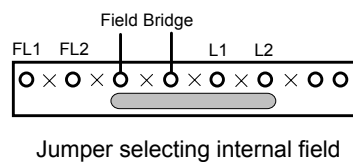
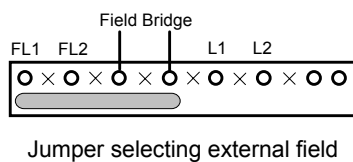
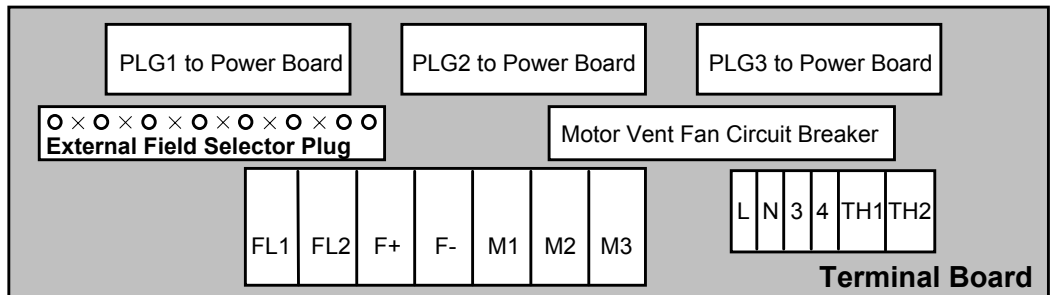

Figure 3-8 Typical connection diagram

Terminal Board - PCB Reference 470330 (Frame 2)

The position of the jumper selects the board to use either an internal or external motor field.



○ fitted pin
× non-fitted pin

Internal Motor Field (default for this board)

Terminals F+ and F-, the motor field outputs, are energised when the 3-phase supply is connected to L1/L2/L3. Terminals FL1 and FL2 are not required. The internal motor field supply is fused by 10A fuses, FS5 & FS6.

External Motor Field

Terminals FL1 and FL2 can be used for external ac supply connection for the Motor Field Supply. You should provide suitably rated external, fast-acting semi-conductor fusing, to a maximum of 10A.

Caution

When using an external ac input it is important to have the correct phase relationship on the terminals. The supply must be derived from L1 (Red) and L2 (Yellow) phases directly or indirectly through a single-phase transformer.
L1 must be connected to FL1, and L2 connected to FL2.

The external field supply can now be connected and power restored to the drive.

Power Board - PCB Reference 385851 (Frame 3)

This power board (printed with the above number) can be altered for use with either an internal or external motor field supply:

Internal Motor Field (default for this board)

Terminals D3 and D4, the motor field outputs, are energised when the 3-phase supply to L1/L2/L3 is energised and the internal motor field is used. Terminals D1 and D2 are not energised. The internal motor field supply is fused by the 10A fuses, FS2 & FS3.

External Motor Field Connections

Terminals D1 and D2 on the Power Board can be used for an external ac supply connection for the Motor Field Supply.

A simple re-wiring procedure disconnects the internal motor field supply and prepares terminals D1 and D2 for the external ac supply connection.

You should provide suitably rated external, fast-acting semi-conductor fusing, to a maximum of 10A.

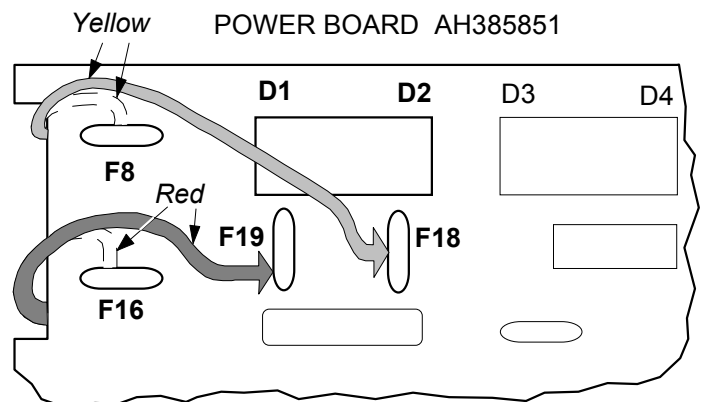

Re-Wiring Procedure

WARNING!

Isolate all power to the drive.

1. Loosen the control board fixing screws (2 off) and position the control board to allow access to the power board.
2. Remove the **red** link from the Faston connector “F16” on the left-hand side of the board and connect it to staging post “F19”, located below terminal D1.
3. Remove the **yellow** link wire from the Faston connector “F8” on the left-hand side of the board and connect it to staging post “F18”, located below terminal D2.

3-24 Installing the Converter

Caution

When using an external ac input it is important to have the correct phase relationship on the terminals. The supply must be derived from L1 (Red) and L2 (Yellow) phases directly or indirectly through a single phase transformer.
L1 must be connected to D1, and L2 connected to D2.

The external field supply can now be connected and power restored to the drive.

Power Board – PCB Reference 466701 (Frames 4 & 5)

This power board (printed with the above number) can be altered for use with either an internal or external motor field supply:

Internal Motor Field (default for this board)

Terminals F+ and F-, the motor field outputs, are energised when the 3-phase supply to L1/L2/L3 is energised and the internal motor field is used. Terminals FL1 and FL2 are not energised. The internal motor field supply is fused by the 30A fuses FS1 and FS2.

External Motor Field Connections

Terminals FL1 and FL2 on the Power Board can be used for an external ac supply connection for the Motor Field Supply.

A simple re-wiring procedure disconnects the internal field supply and prepares terminals FL1 and FL2 for the external ac supply connection.

You should provide suitably rated external, fast-acting semi-conductor fusing, to a maximum of 30A.

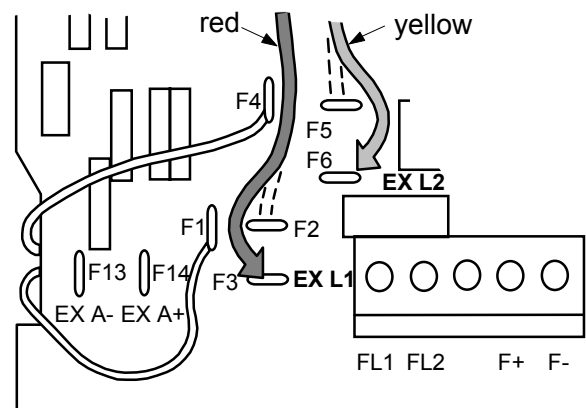

Re-Wiring Procedure

WARNING!

Isolate all power to the drive.

1. Loosen the control board fixing screws (2 off) and position the control board to allow access to the power board.
2. Remove the **red** link from the Faston connector “F2” and connect it to the staging post “F3” nearby (EX L1).
3. Remove the **yellow** link wire from the Faston connector “F5” and connect it to the staging post “F6” nearby (EX L2).

Caution

When using an external ac input it is important to have the correct phase relationship on the terminals. The supply must be derived from L1 (Red) and L2 (Yellow) phases directly or indirectly through a single phase transformer.
L1 must be in phase with FL1, and L2 must be in phase with FL2.

The external field supply can now be connected and power restored to the drive.

DC Contactor - External VA Sensing

Connections are provided for external armature voltage sensing (at the motor) for when a dc contactor is used between the drive and motor.

Power Board - PCB Reference 385851 (Frame 3)

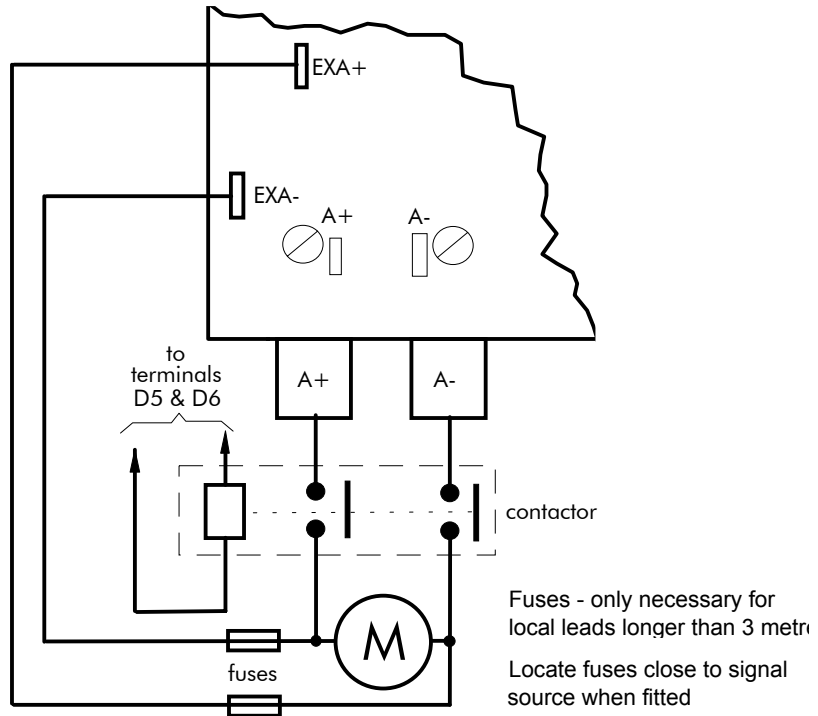

Power Board - PCB Reference 466701 (Frames 4 & 5)

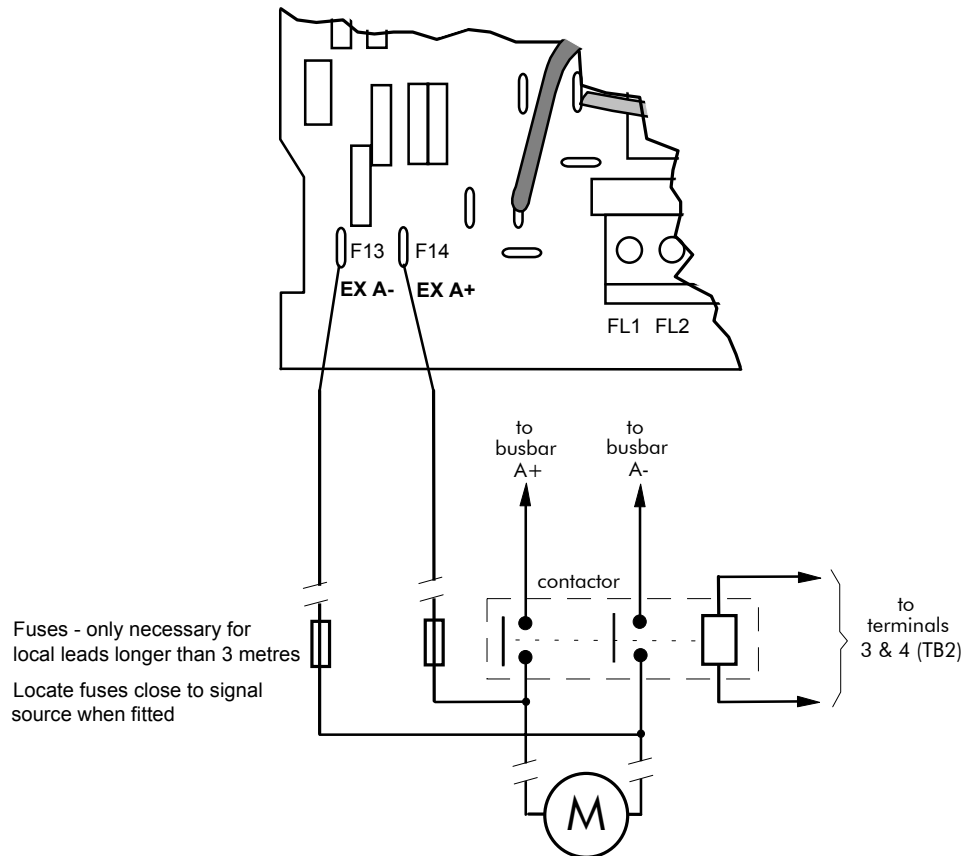

3-26 Installing the Converter

External Connections (Frame H)

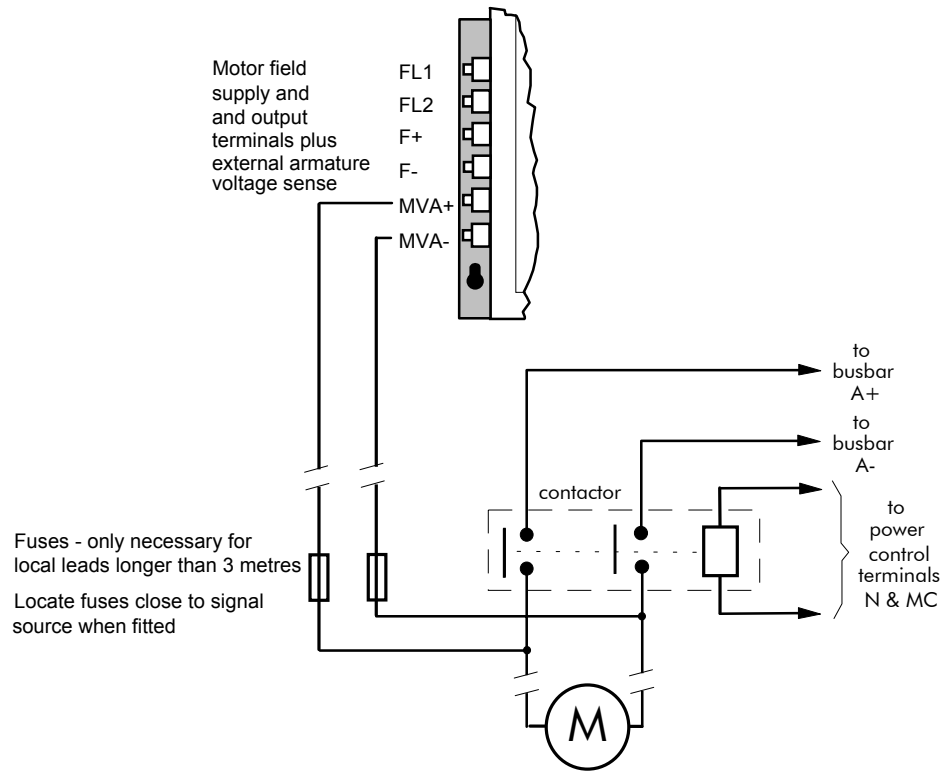

Optional Equipment

Fitting the Remote 6901 Operator Station



The 6052 Mounting Kit is required to remote-mount a 6901 Operator Station. It is possible to remote-mount the drive-mounted Operator Station using the port illustrated

You can also replace an Operator Station for a PC running ConfigEd Lite (or other suitable PC programming tool) in all of the options above. Refer to the Software Product Manual: "Serial Communications".

6052 Mounting Kit Parts for the Remote Operator Station

Tools Required

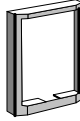
No. 2 Posidrive screwdriver.

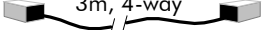
6052 Mounting Kit			
1		1	
4	 No. 6 x 12mm	1	 3m, 4-way

Assembly Procedure

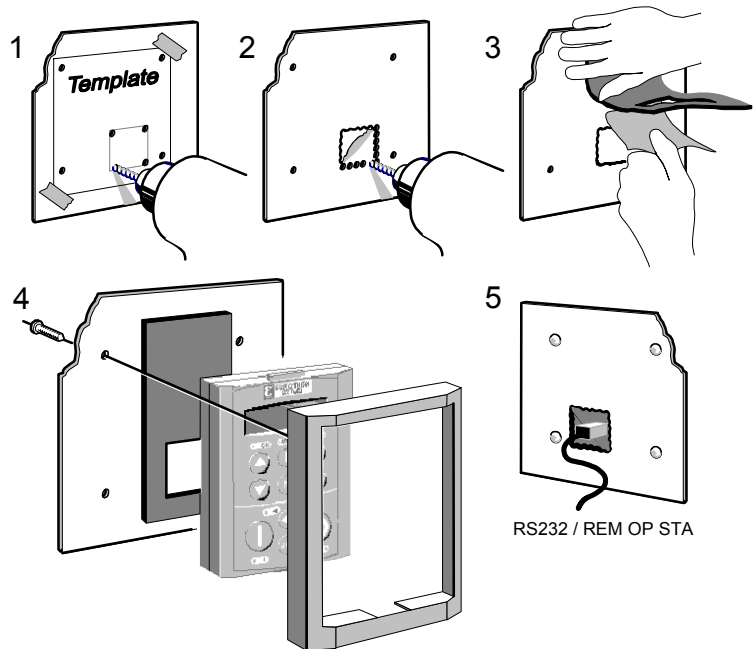

Cutout Dimensions

An actual size template is provided with Operator Station/6052 Mounting Kit.

Figure 3-9 Mounting Dimensions for the Remote-Mounted Operator Station 6901

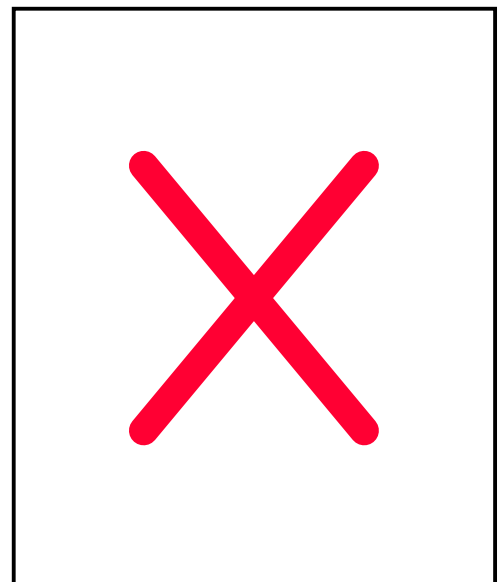

3-28 Installing the Converter

Speed Feedback and Technology Options

The Options are:

1. Speed Feedback (Analog Tacho Calibration Option Board or Microtach/Encoder Feedback Option Card)
2. Communications Technology Box (6055 - LINK II, Profibus, DeviceNet, Serial RS485)

They are plugged into the two positions, as illustrated.

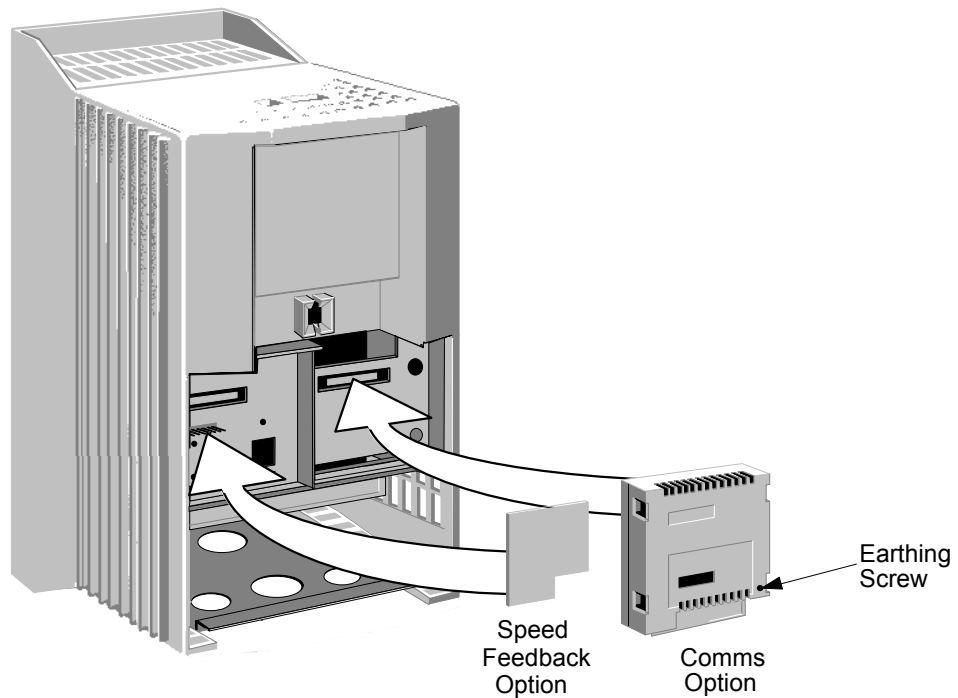

You can operate the Inverter with the Speed Feedback and/or Communications Technology Options.

Refer to the appropriate Technology Option Technical Manual for further information.

Removal

After removing the earthing screw, remove the COMMS option by carefully pushing a long screwdriver (for instance) under the option and gently levering it out. The pins are protected by the option moulding.

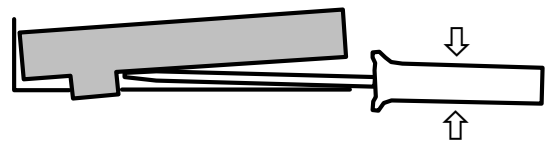

WARNING!

Isolate the drive before fitting or removing the options.

External AC Supply EMC Filter Installation

Refer to Chapter 11: “Technical Specifications” - Environmental Details, and External AC Supply (RFI) Filters and Line Choke for selection details.

A filter is used with the Converter to reduce the line conducted emissions produced by the Converter. Filters are used in parallel on the higher current Converters. When installed correctly and used with the specified 2% minimum line chokes, conformance with EN55011 Class A can be achieved (suitable for both generic environments: RF Emission and Immunity).

Cubicle-Mounting the 590+ Converter with Filter

WARNING!

Do not touch filter terminals or cabling for at least 3 minutes after removing the ac supply.

Only use the ac supply filter with a permanent earth connection.

The filter should be fitted on the mains side of the contactor.

The Converter must be mounted vertically on a solid, flat, vertical surface. It must be installed into a cubicle.

The recommended EMC filter is mounted to the left, right, above, below, or spaced behind the Converter. It can be mounted flat against the surface, or projecting out from the surface if the filter type has side fixings.

1. Mount the filter securely at the four fixing points (flat or on its side).
2. Mount the Converter next to the filter, allowing for the required airgap between the Converter, the filter and any adjacent equipment.

Connection Details

The connection between the Converter, choke and filter must always be as short as possible and **must be segregated from all other cables**. Ideally, mount the filter and choke onto the same metallic panel as the Converter. Take care not to obstruct any ventilation spacing.

If this cable/busbar exceeds 0.6m (2 feet) in length, it must be replaced with a screened/armoured cable. The screen/armor must be earthed at both the filter, choke and Converter ends with large-area contact surfaces, preferably with metal cable glands.

You should enhance the RF connection between the Converter, choke, filter and panel as follows:

1. Remove any paint/insulation between the mounting points of the EMC filter, choke, Converter and the panel. Liberally apply petroleum jelly over the mounting points and securing threads. This will prevent corrosion. Alternatively, conducting paint could be used on the panel.
2. If 1 above is not possible, then improve the RF earth bond between the filter and Converter by making an additional RF earth connection. Use wire braid of at least 10mm² cross-sectional area.

Note: *Metal surfaces, such as anodised or yellow chromed (with cable mounting or 35mm DIN rails, screws and bolts) have a high impedance which can be very detrimental to EMC performance.*

3. A low RF impedance path must be provided between the motor frame and back panel on which the drive, choke and EMC filters are mounted. This low impedance RF path should follow the path of the motor cables in order to minimise the loop area. **Failure to do so will result in increased conducted emissions.**

A low RF impedance path will normally be achieved by:

- Bonding the armour of the motor supply cables at one end to the motor frame, and at the

3-30 Installing the Converter

other end to the cubicle back panel. Ideally 360° bonding is required, which can be achieved with cable glands, refer to Figure 3-5 360 Degree Screened Connection, page 3-6.

- Ensuring that conduit containing the motor supply cables are bonded together using braid. The conduit should also be bonded to the motor frame and the cubicle back panel.

Earthing Details

The protective earth (PE) conductor exiting the filter must be connected to the protective earth connection of the Converter. Any additional RF earth, such as a cable screen, **is not a protective earth**. The EMC filter must be **permanently earthed** to prevent the risk of electric shock under abnormal operating instances (such as the loss of one phase of the ac supply).

You can achieve permanent earthing by either:

- using a copper protective earth conductor of at least 10mm²
- installing a second conductor, in parallel connection with the protective conductor, to a separate protective earth terminal

Each conductor must independently meet the requirements for a protective earth conductor.

Operating Conditions

The recommended EMC filters operate from normal three-phases supplies which are balanced with respect to earth (earth referenced supplies - TN). This minimises the earth leakage current due to the filter capacitors between phase and earth.

IMPORTANT: We do not recommend the use of ac supply filters on non earth-referenced supplies - IT. The supplies cause earth leakage currents to increase, and interfere with the operation of earth fault monitoring equipment. In addition, EMC performance of the filter is degraded.

As with all power electronic drives, conducted emissions increase with motor cable length. EMC conformance is only guaranteed up to a cable length of 50m. The cable length can be increased. Refer to Eurotherm Drives for more information.

Earth Fault Monitoring Systems

WARNING!

Circuit breakers used with VSDs and other similar equipment are not suitable for personnel protection. Use another means to provide personal safety. Refer to EN50178 (1998) / VDE0160 (1994) / EN60204-1 (1994)

We do not recommend the use of circuit breakers (e.g. RCD, ELCB, GFCI), but where their use is mandatory, they should:

- Operate correctly with dc and ac protective earth currents (i.e. type B RCDs as in Amendment 2 of IEC755).
- Have adjustable trip amplitude and time characteristics to prevent nuisance tripping on switch-on.

Note: *When the ac supply is switched on, a pulse of current flows to earth to charge the EMC filter internal capacitors which are connected between phase and earth. This has been minimised in Eurotherm Drives filters, but may still trip out any circuit breaker in the earth system. In addition, high frequency and dc components of earth leakage currents will flow under normal operating conditions. Under certain fault conditions larger dc protective earth currents may flow. The protective function of some circuit breakers cannot be guaranteed under such operating conditions.*

Installation Drawings

Converter Installation Drawings

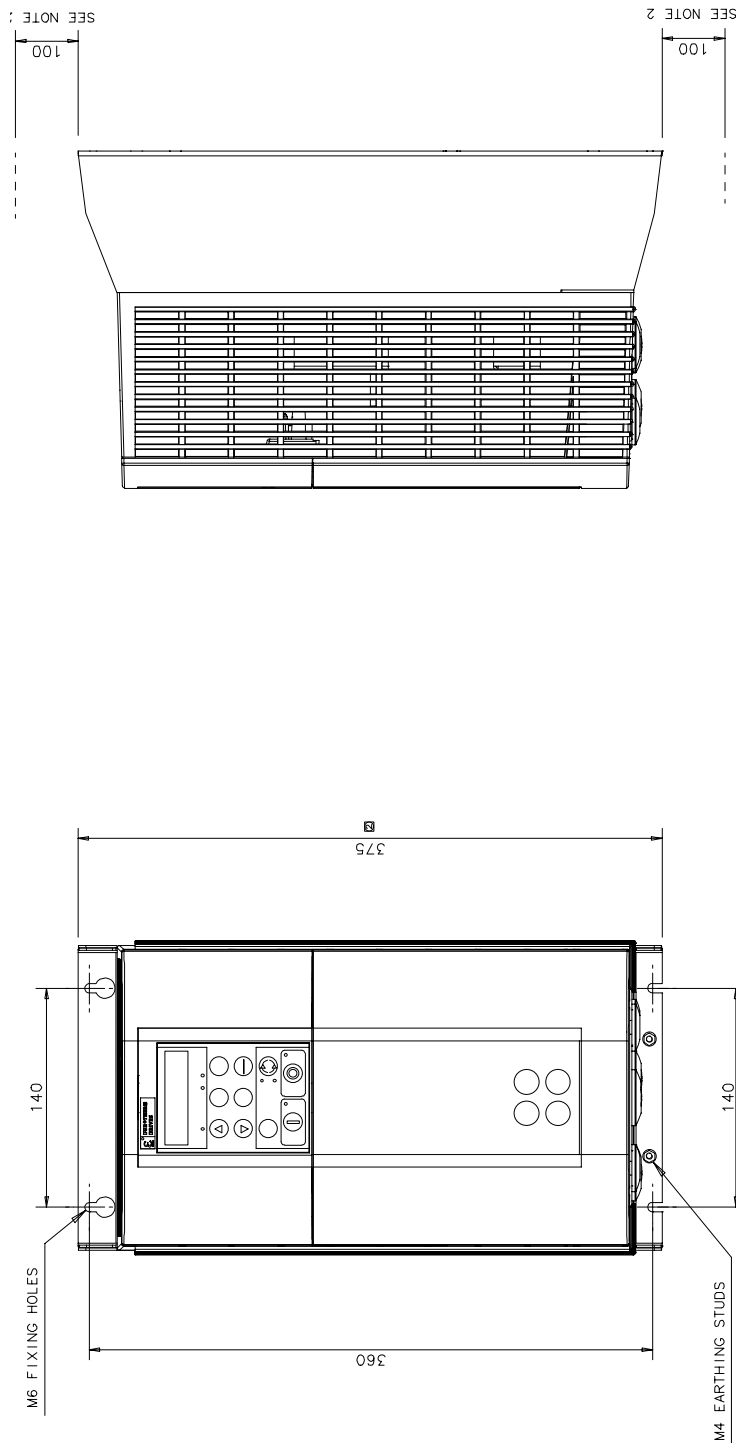

- NOTES:
1. FOR DETAILS OF ELECTRICAL CONNECTIONS SEE PRODUCT MANUAL.
 2. AT LEAST 100mm CLEARANCE ABOVE AND BELOW UNIT MUST BE PROVIDED FOR COOLING AIR.
 3. IT IS NECESSARY TO REMOVE FRONT COVER AND GLAND PLATE WHEN ELECTRICAL CONNECTIONS ARE BEING MADE.
 4. MECHANICAL MOUNTING FIXING ARE NOT SUPPLIED.

© 1998 EUROTHERM DRIVES LTD./INC

Figure 3-10 Frame 1 : 15A & 35A Stack Assembly – Drg. No. HG466465

3-32 Installing the Converter

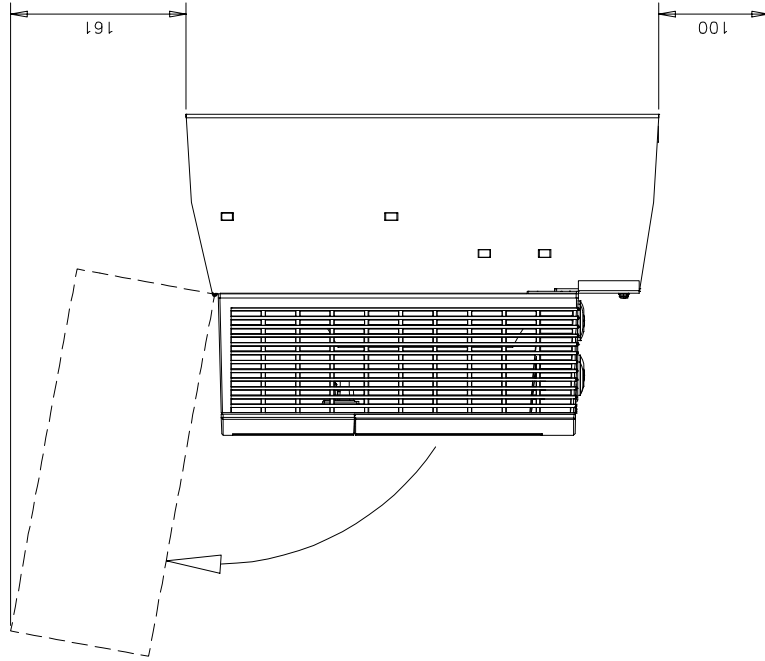

- NOTES
1. FOR DETAILS OF ELECTRICAL CONNECTIONS SEE MANUAL.
 2. AT LEAST 161mm CLEARANCE ABOVE UNIT MUST BE PROVIDED FOR INSTALLATION.
 3. AT LEAST 100mm CLEARANCE BELOW UNIT MUST BE PROVIDED FOR AIR COOLING.
 4. IT IS NECESSARY TO REMOVE COVER AND TERMINAL COVER WHEN ELECTRICAL CONNECTIONS ARE BEING MADE.
 5. MECHANICAL MOUNTING FIXINGS ARE NOT SUPPLIED.

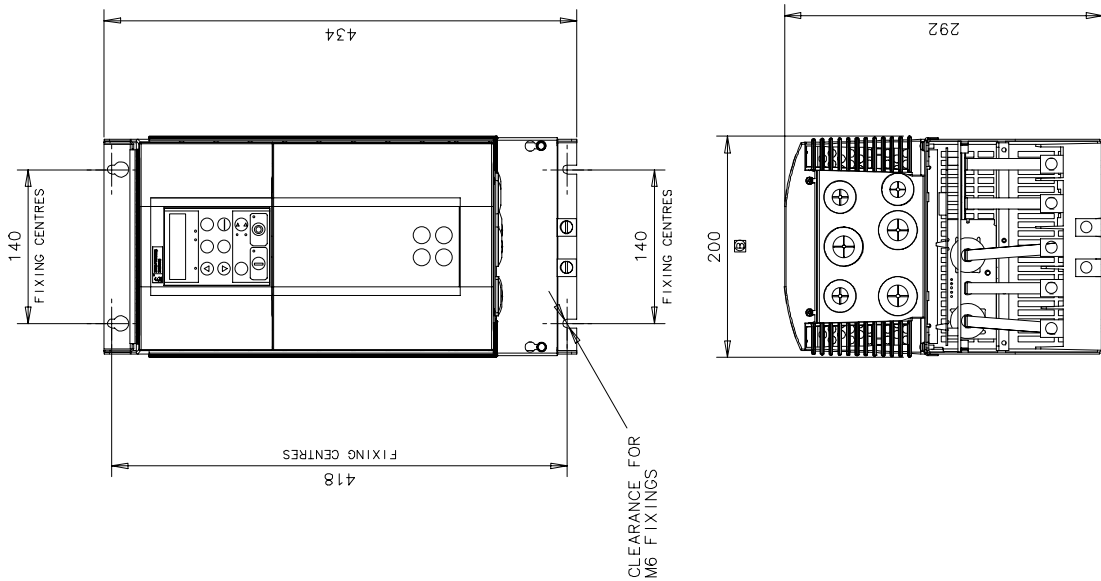

Figure 3-11 Frame 2 : 40A-165A Stack Assembly

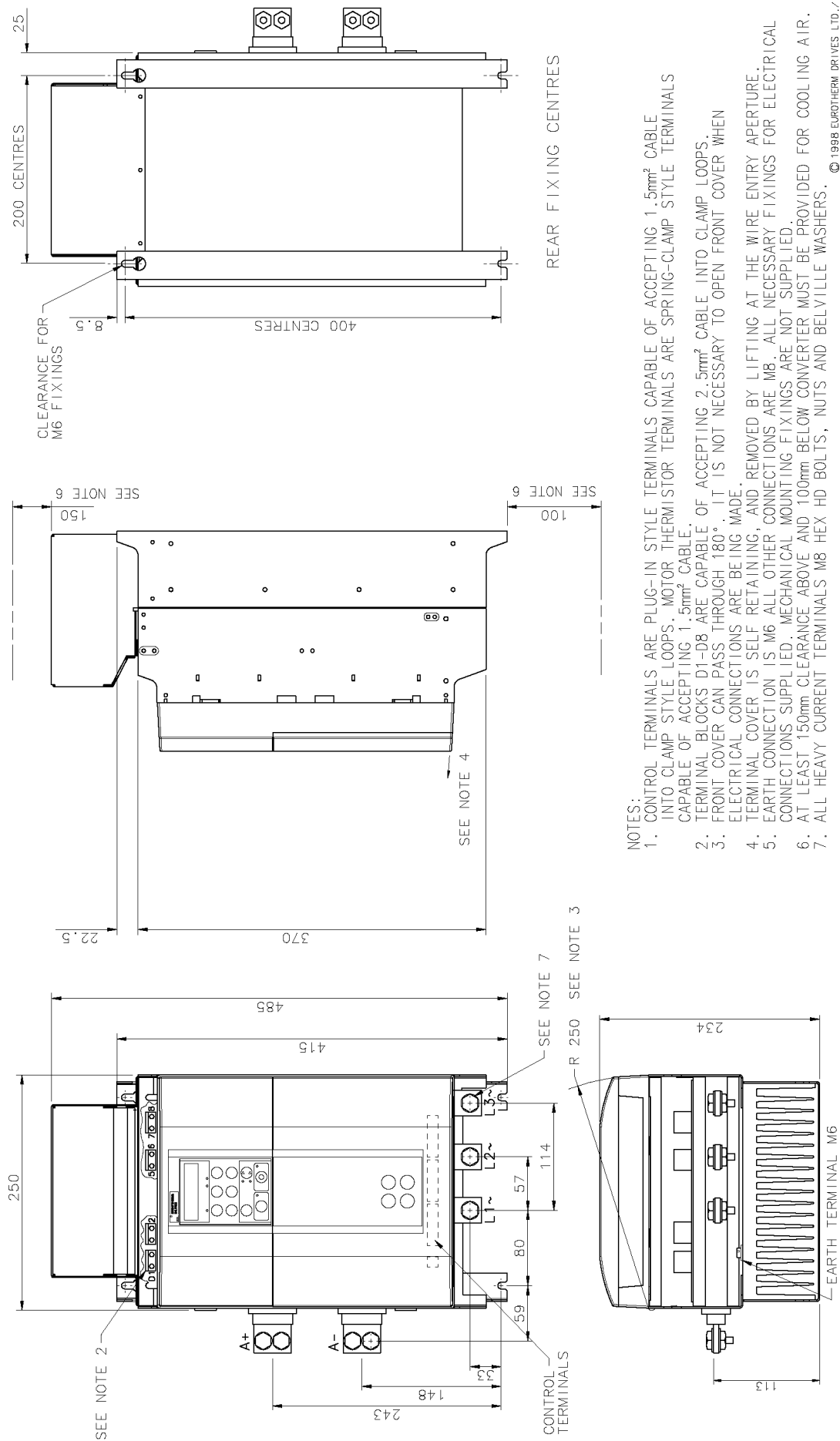
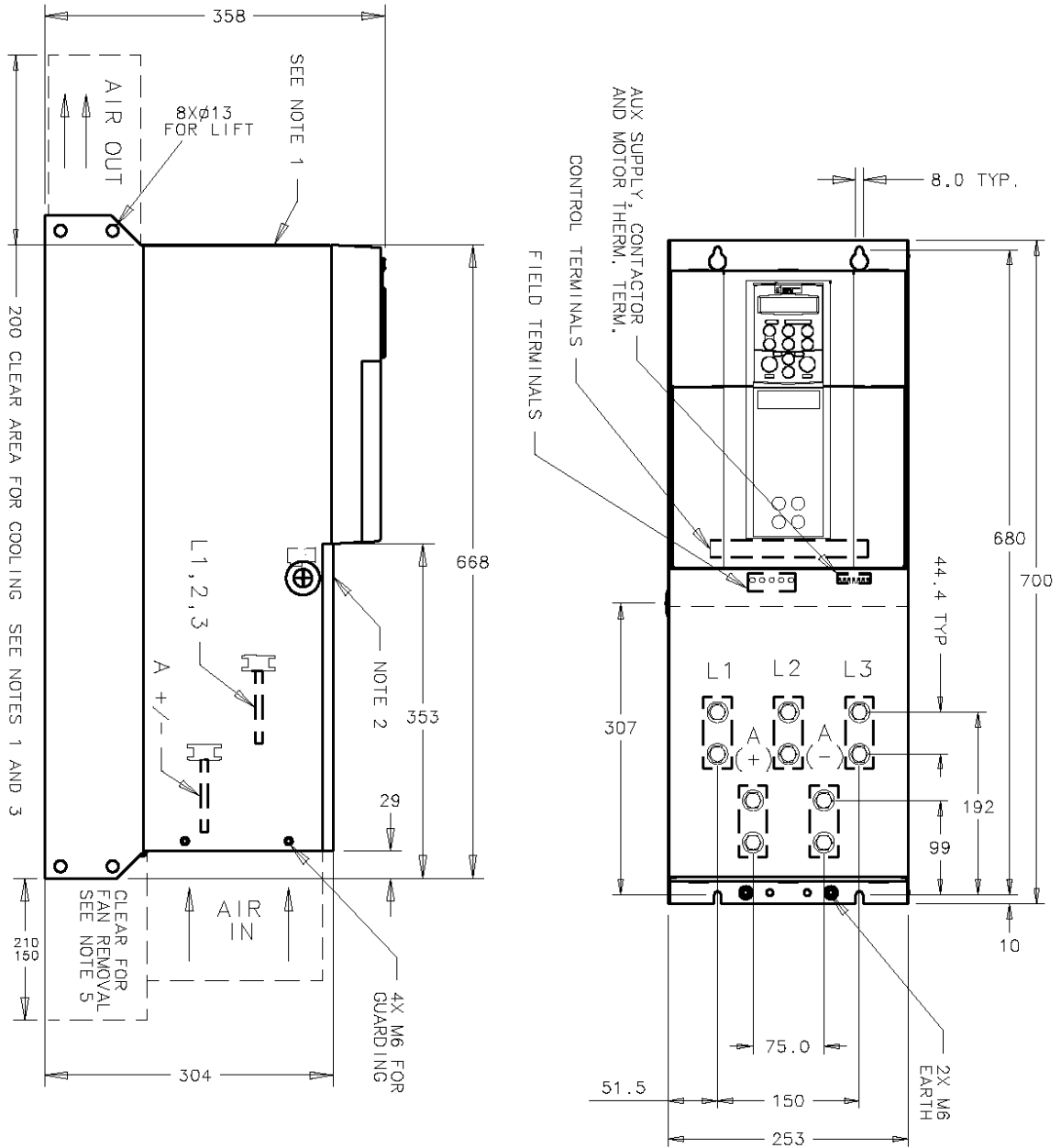

Figure 3-12 Frame 3 : 270A Stack Assembly - Drg No. HG466428

3-34 Installing the Converter



NOTES

1. INTERNAL COOLING AIR ENTERS ON THIS FACE. MAIN COOLING AIR MUST NOT BE DEFLECTED BACK ON THIS SURFACE.
2. TO ENSURE FULL RATING OF FEILD AND INTERNAL CIRCUITS DRIVE MUST BE OPERATED WITH FRONT COVER FITTED
3. SEE DRAWING HG466700U02 FOR DETAILS OF EXTERNAL EXHAUST OPTION.
4. DIMENSION IS TO TOP SURFACE OF BUSBAR FOR 380-500 AMP DRIVE. TWO BARS ARE USED AT EACH POSITION ON 830 AMP DRIVE ADDING 4MM TO DIMENSION
5. AREA BELOW DRIVE MUST BE CLEAR TO REPLACE FAN WITH DRIVE MOUNTED. IF 150 MIN IS USED, THERE MUST BE ROOM ABOVE TO TILT COVER AWAY FROM PANEL IF THIS AREA ISN'T AVAILABLE, THEN THE 210 DIMENSION MUST BE CLEAR AND THERE MUST BE ROOM TO THE SIDE OF THE DRIVE EQUAL TO THE DRIVE WIDTH TO SLIDE COVER OUT.

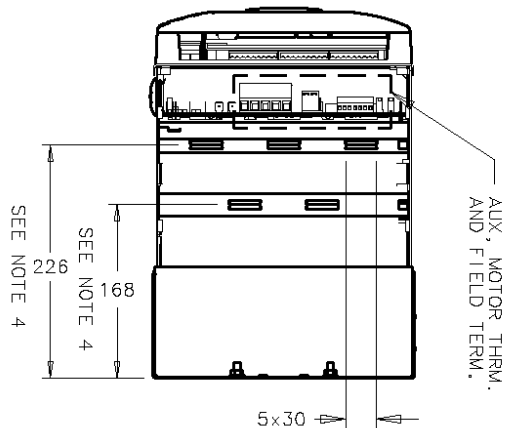
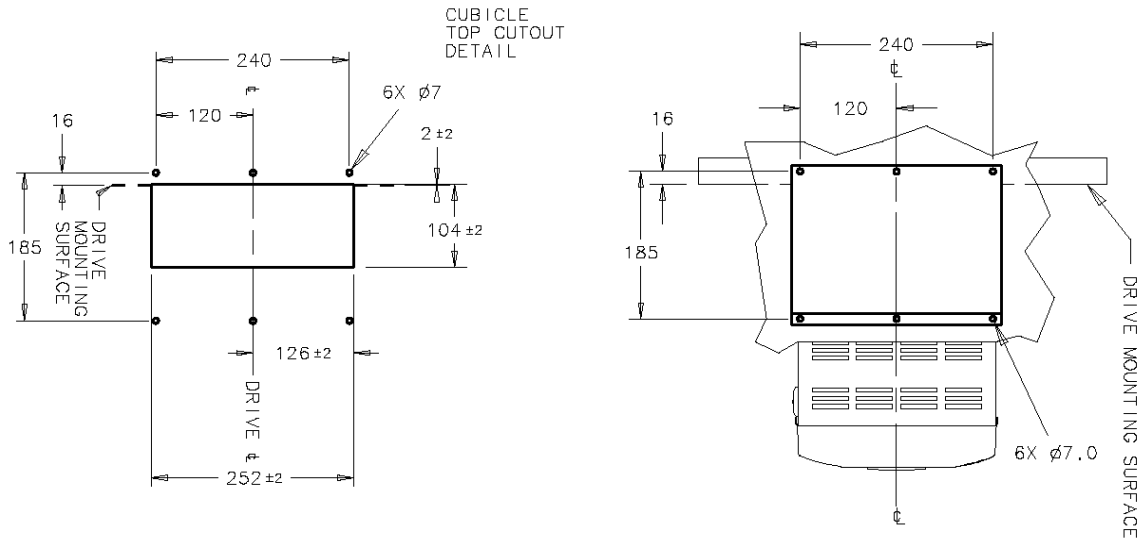

Figure 3-13 Frame 4 : 380-830A Stack Assembly – Drg. No. HG466700U001



- NOTES**
1. SEE HG466700U001 FOR DRIVE DETAIL DIMENSIONS
 2. KIT PROVIDES IP20 PROTECTION, BUT GASKET WILL PREVENT DRIPPING AND STANDING LIQUIDS FROM ENTERING CUBICLE.

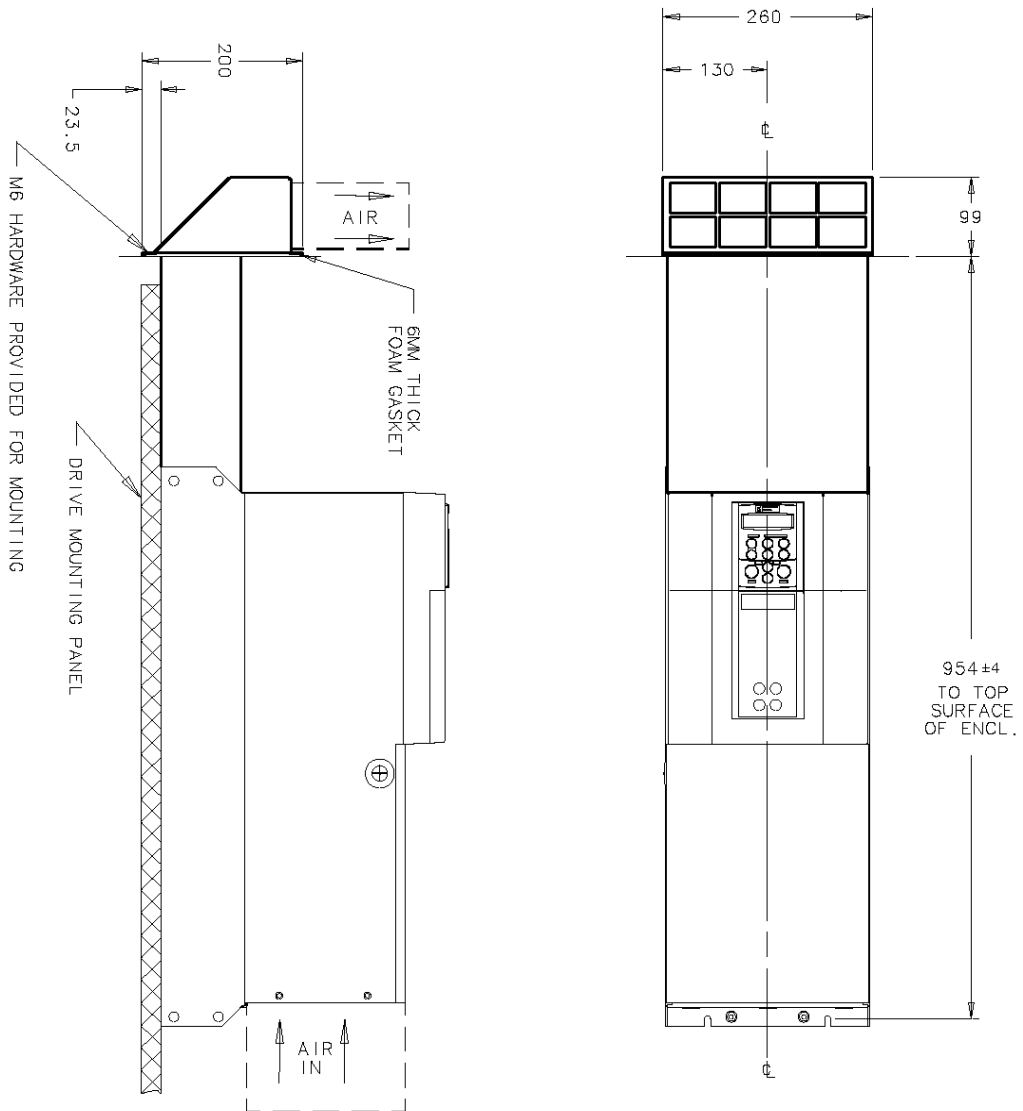
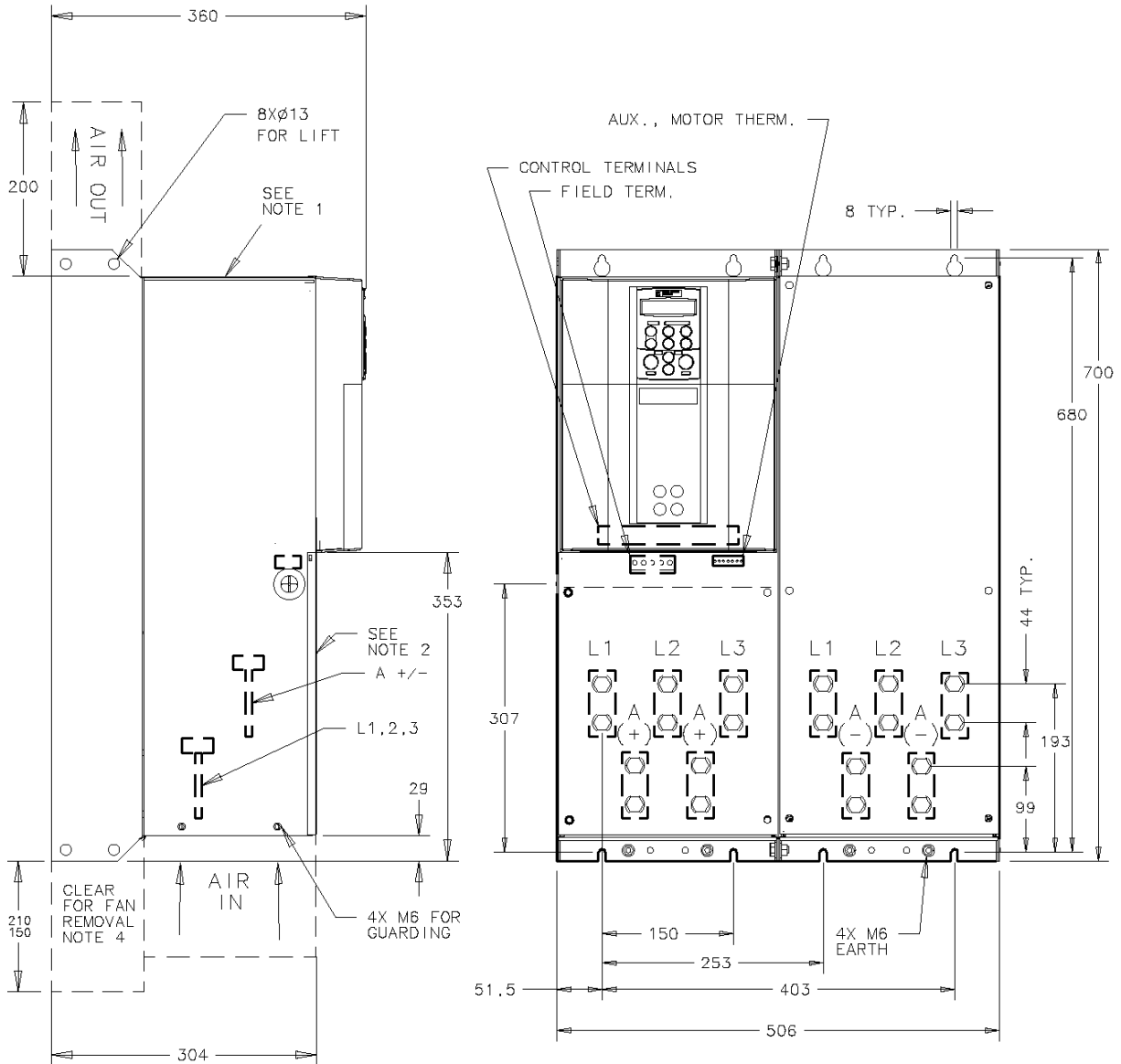

Figure 3-14 Frame 4 : 380-830A External Vent Kit Installation – Drg No. HG466700U002

3-36 Installing the Converter



NOTES

1. INTERNAL COOLING AIR ENTERS ON THIS FACE. MAIN COOLING AIR MUST NOT BE DEFLECTED BACK ON THIS SURFACE.
2. TO ENSURE FULL RATING OF FIELD AND INTERNAL CIRCUITS DRIVE MUST BE OPERATED WITH FRONT COVERS FITTED.
3. SEE DRAWING HG466700U02 FOR DETAILS OF EXTERNAL EXHAUST OPTION.
4. AREA BELOW DRIVE MUST BE CLEAR TO REPLACE FAN WITH DRIVE MOUNTED. IF 150 MIN IS USED, THERE MUST BE ROOM ABOVE TO TILT COVER AWAY FROM PANEL IF THIS AREA ISN'T AVAILABLE, THEN THE 210 DIMENSION MUST BE CLEAR AND THERE MUST BE ROOM TO THE SIDE OF THE DRIVE EQUAL TO THE DRIVE WIDTH TO SLIDE COVER OUT.

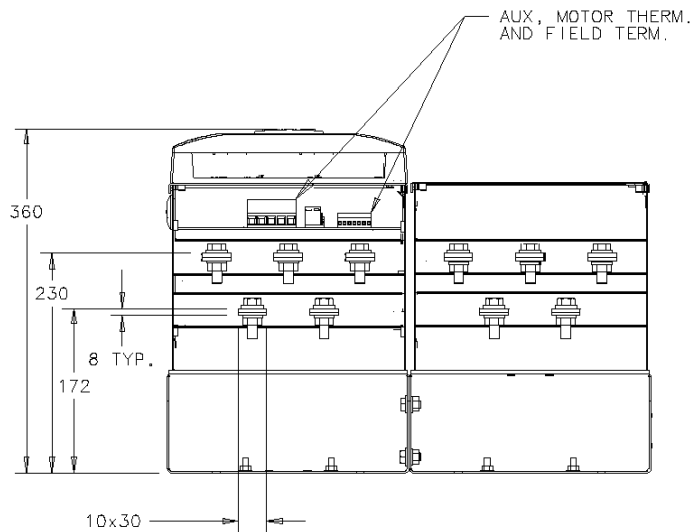
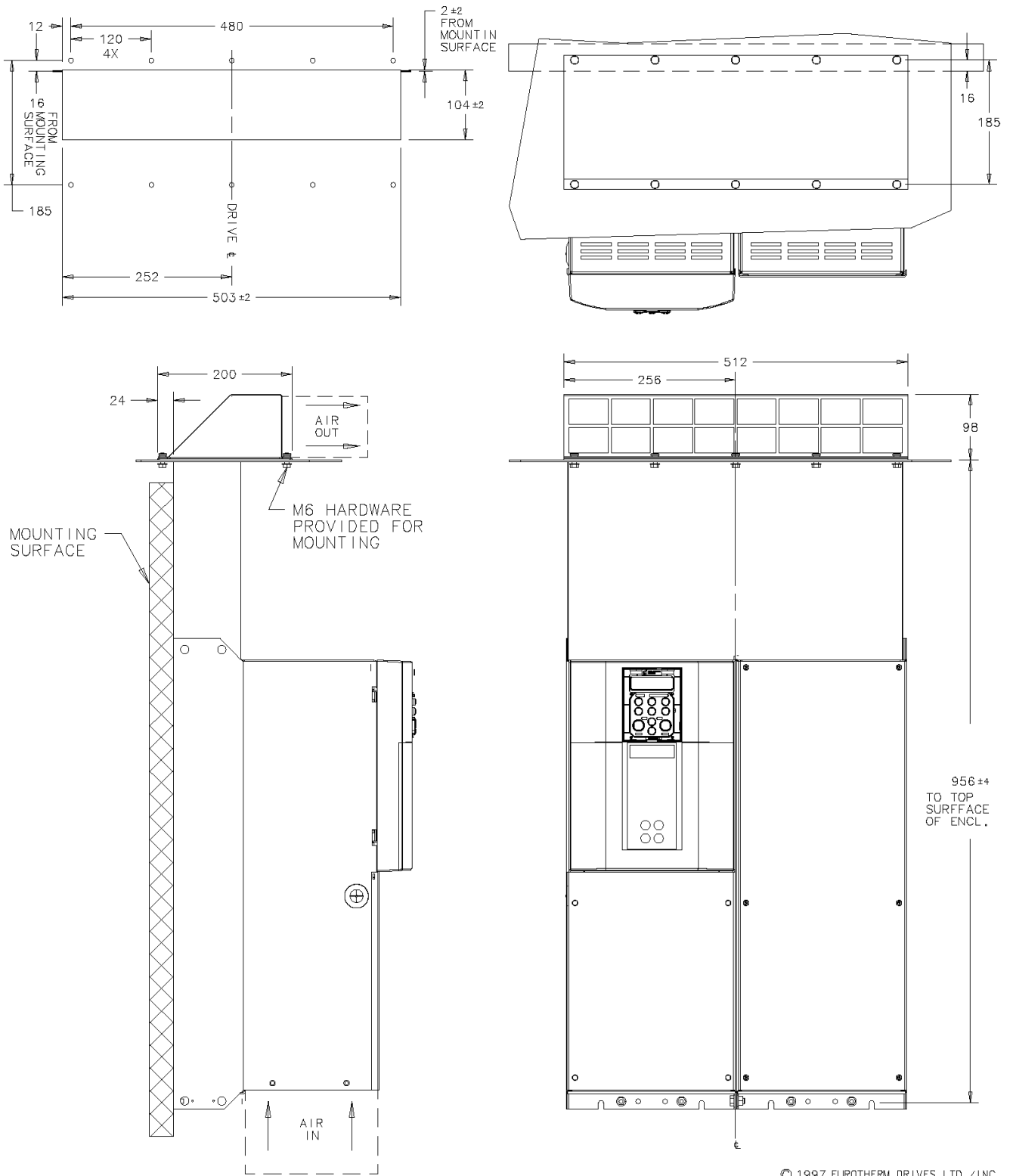

Figure 3-15 Frame 5 : 1580A Stack Assembly – Drg No. HG466700U110

Installing the Converter 3-37



© 1997 EURO THERM DRIVES LTD./INC.

Figure 3-16 Frame 5 : 1580A External Vent Kit Installation – Drg No. HG466700U111

3-38 Installing the Converter

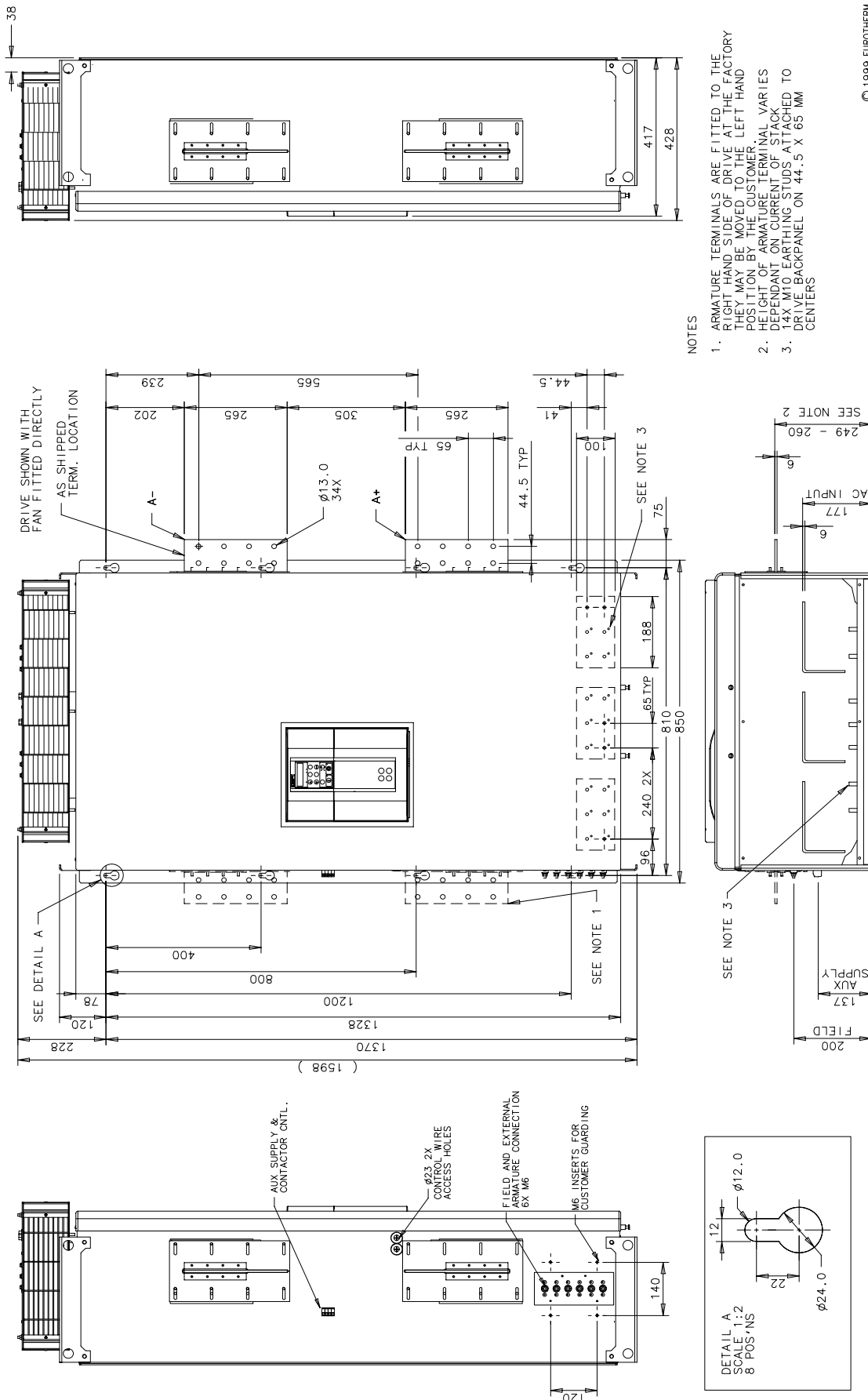

Figure 3-17 Frame H : 1200A-2700A Stack Assembly (Regenerative) - Drg No. HG466432U000/1

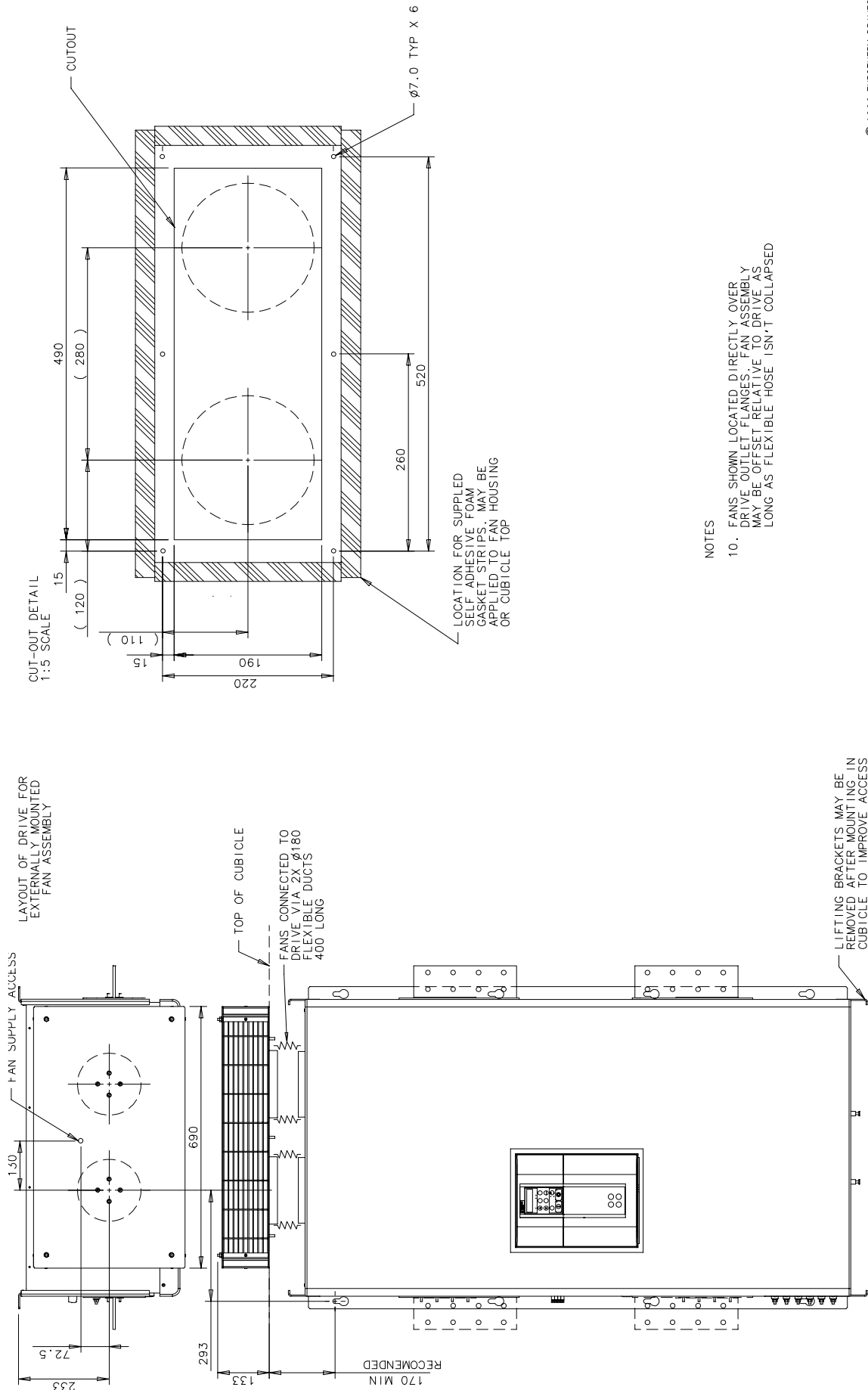
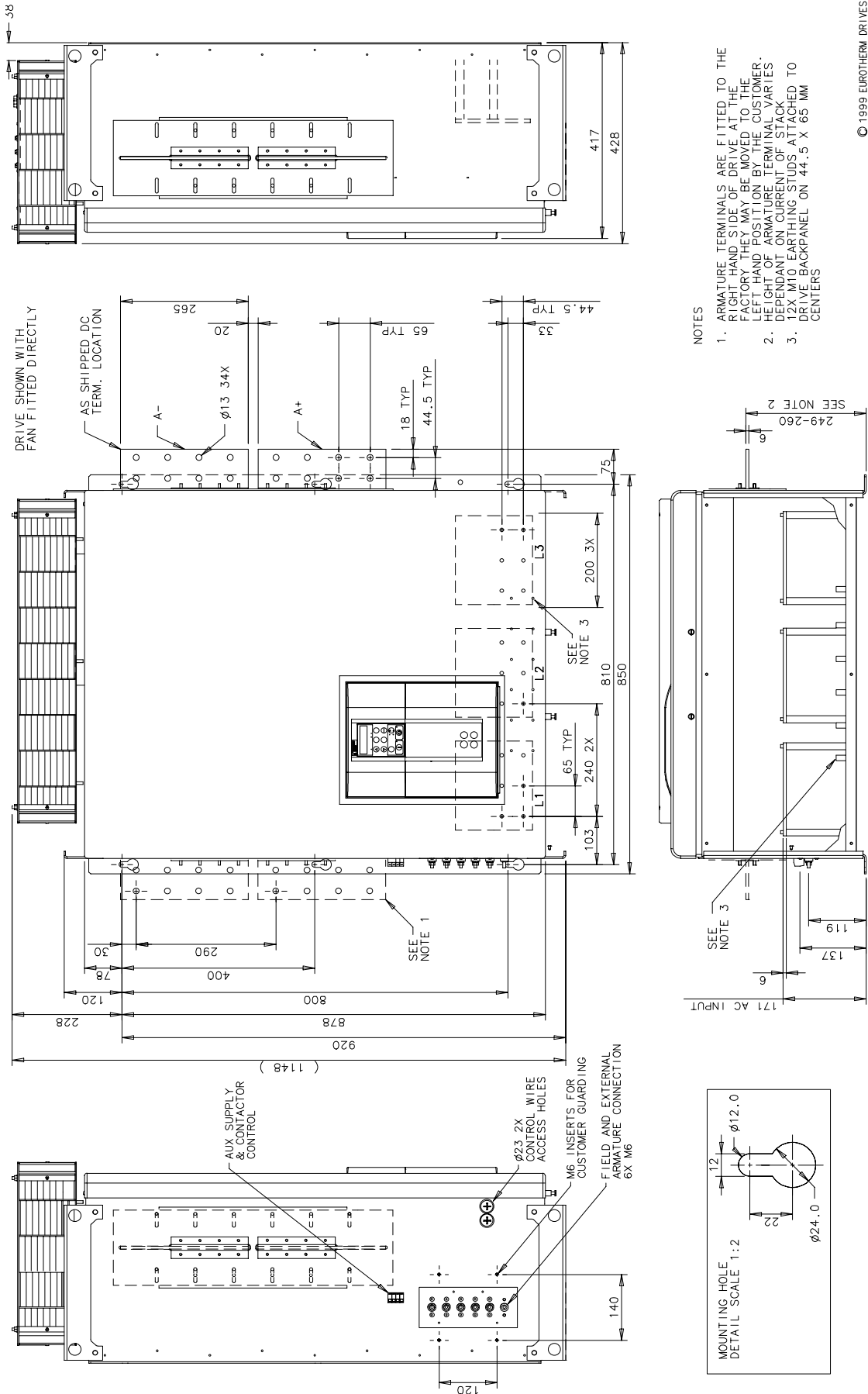

Figure 3-18 Frame H : 1200A-2700A Stack Assembly (Regenerative) - Drg No. HG466432U000/2

3-40 Installing the Converter



© 1995 EUROTHERM DRIVES LTD./INC.

Figure 3-19 Frame H : 1200A-2700A Stack Assembly (Non-regenerative) - Drg No. HG466433U000/1

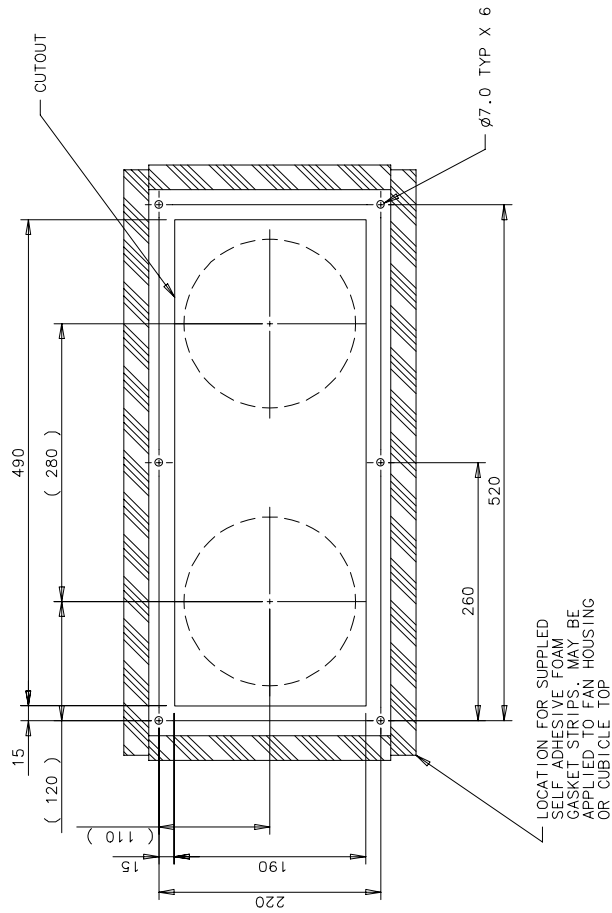

NOTES

- FANS SHOWN LOCATED DIRECTLY OVER DRIVE OUTLET FLANGES. FAN ASSEMBLY MAY BE OFFSET RELATIVE TO DRIVE AS LONG AS FLEXIBLE HOSE ISN'T COLLAPSED.

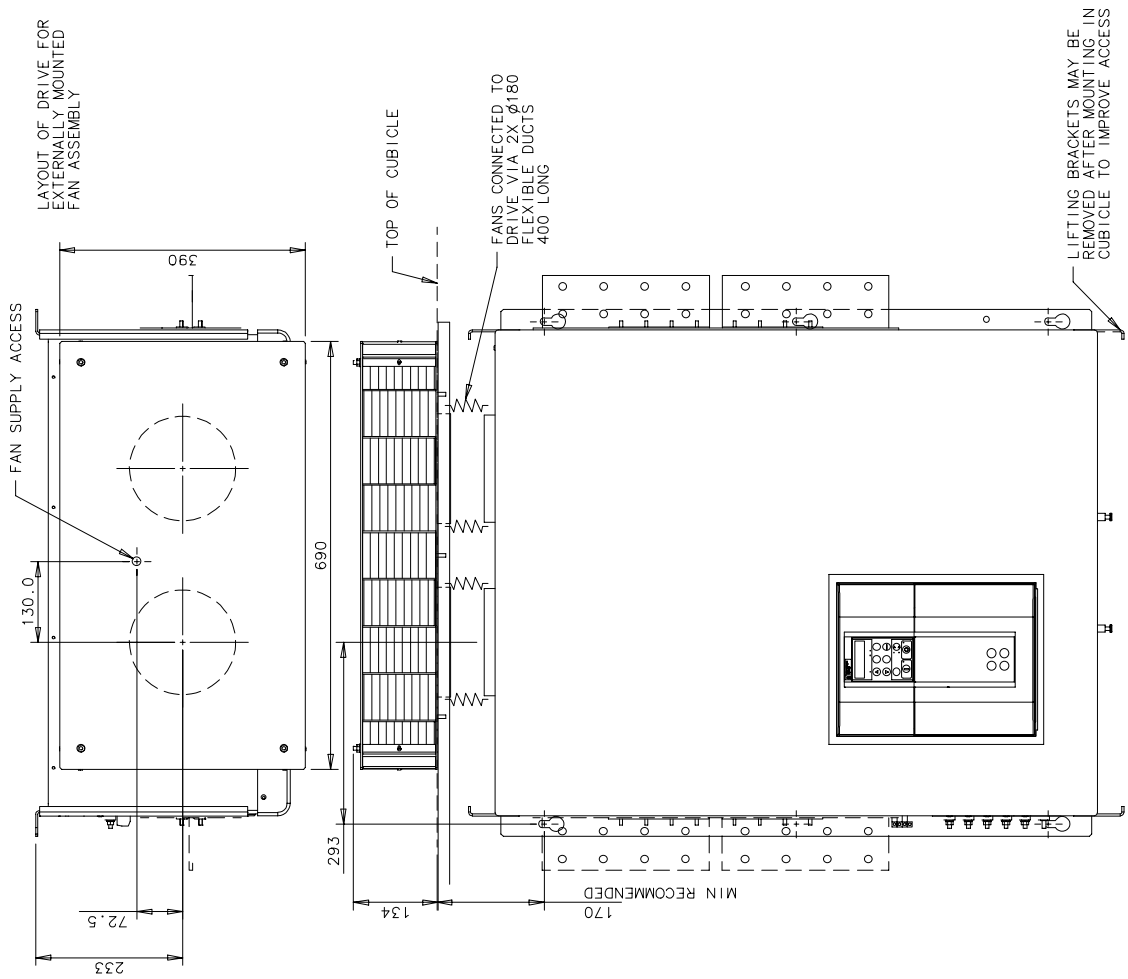

Figure 3-20 Frame H : 1200A-2700A Stack Assembly (Non-regenerative) - Drg No. HG466433U000/2

Filter Installation Drawings

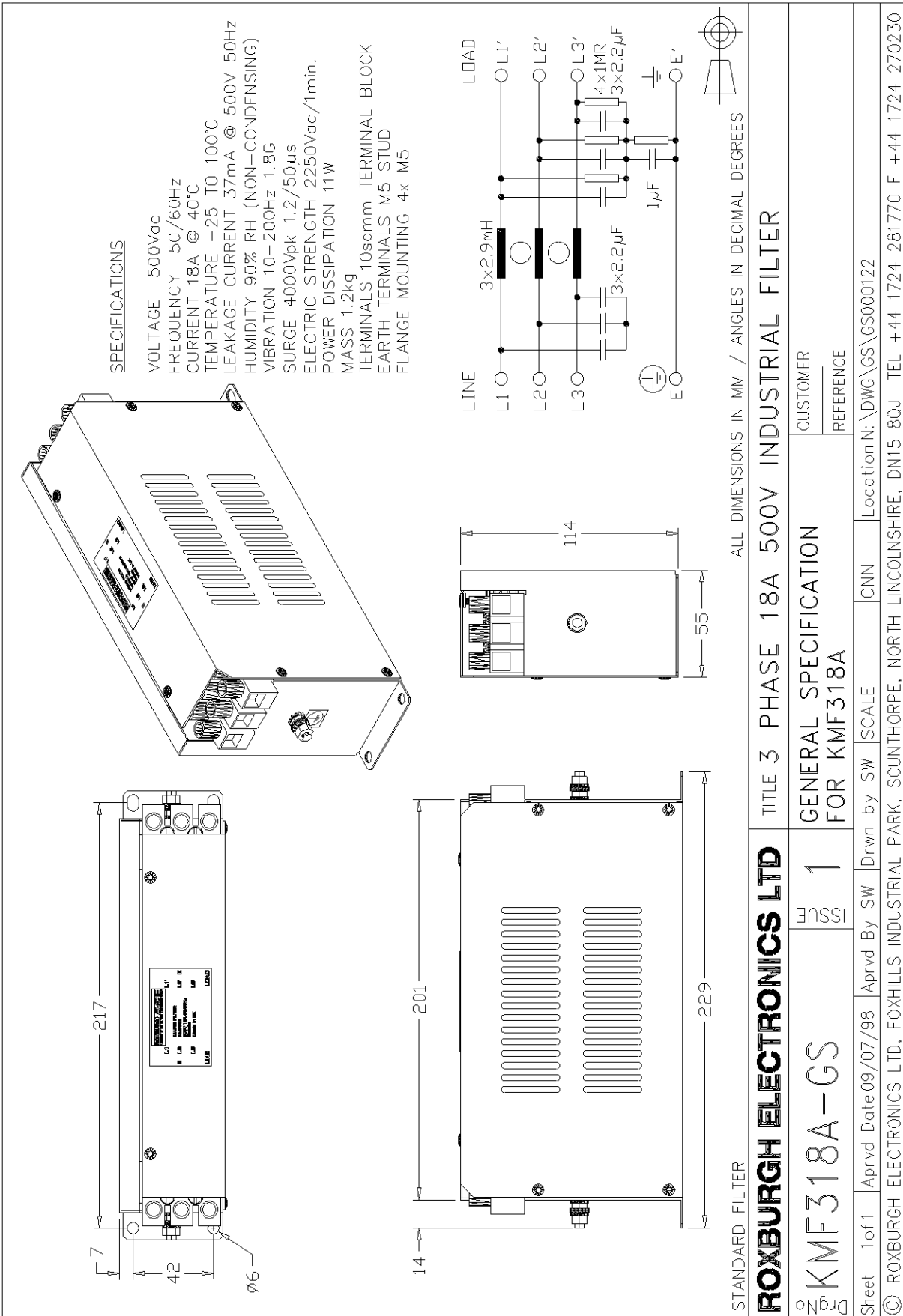

Figure 3-21 Filter Mounting Details, Part No. CO466516U015 for Frame 1 : 15 Amp

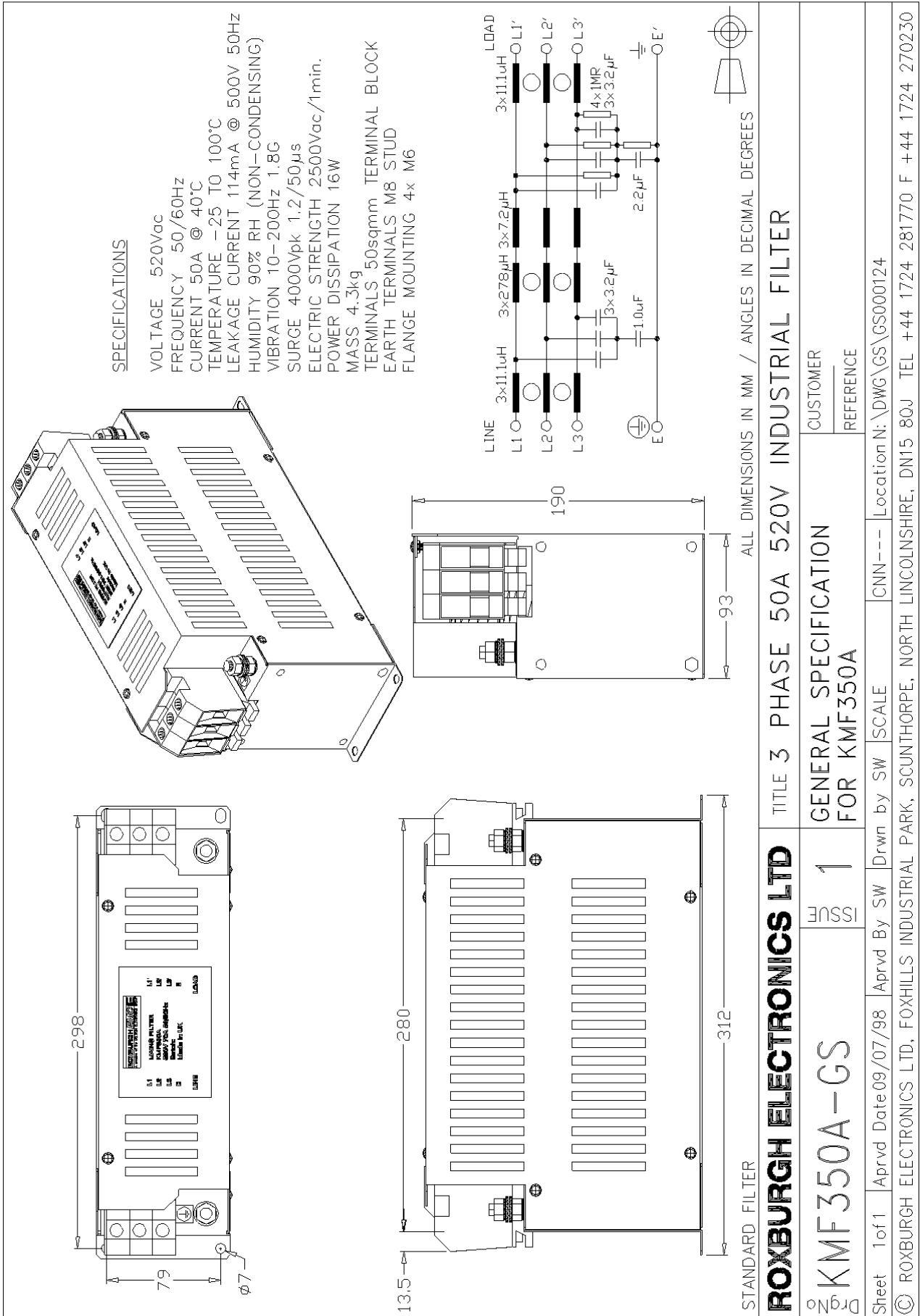

Figure 3-22 Filter Mounting Details, Part No. CO466516U040 for Frame 1: 35 & Frame 2 : 40 Amp

3-44 Installing the Converter

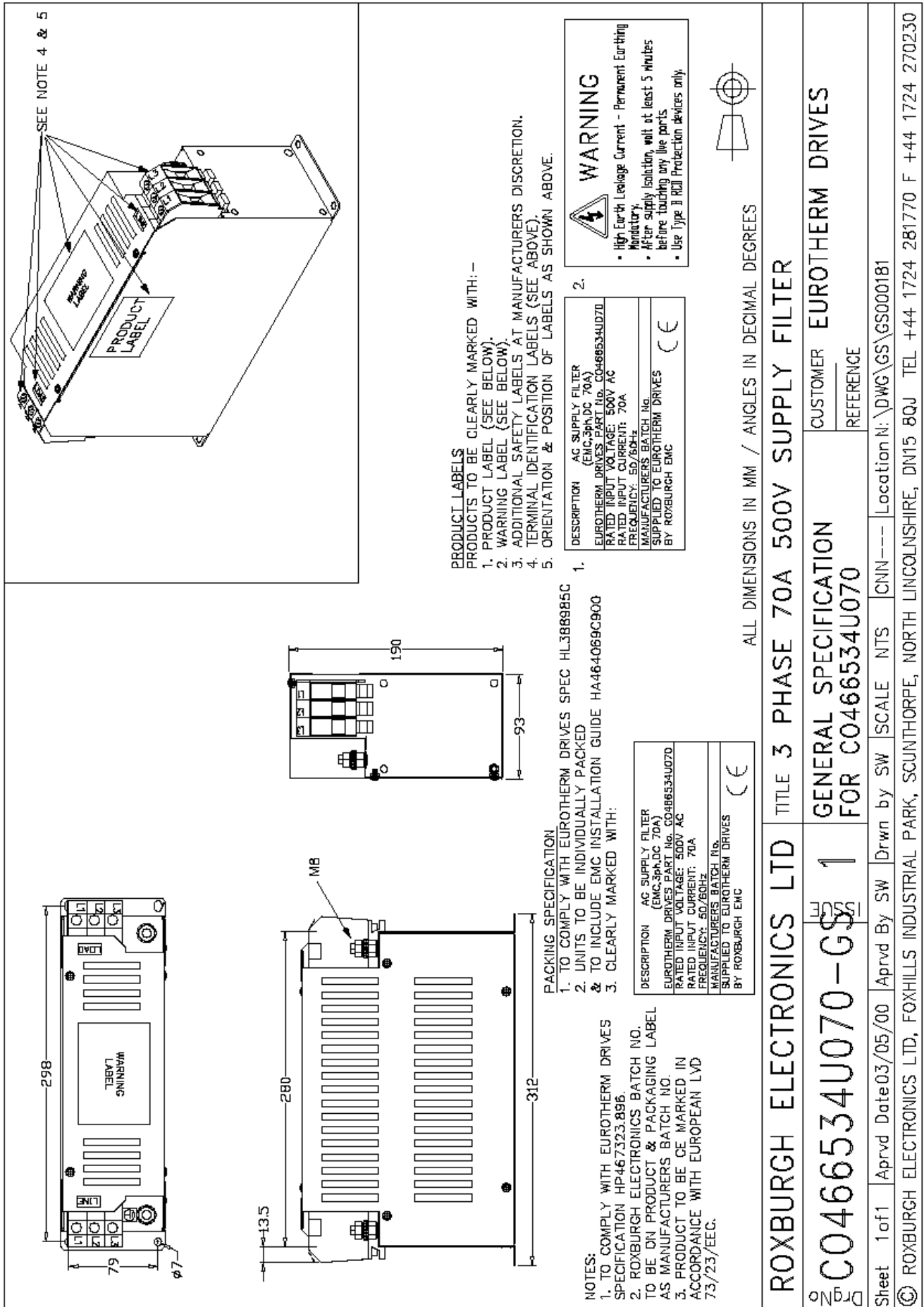

Figure 3-23 Filter Mounting Details, Part No. CO466534U070 for Frame 2 : 70 Amp

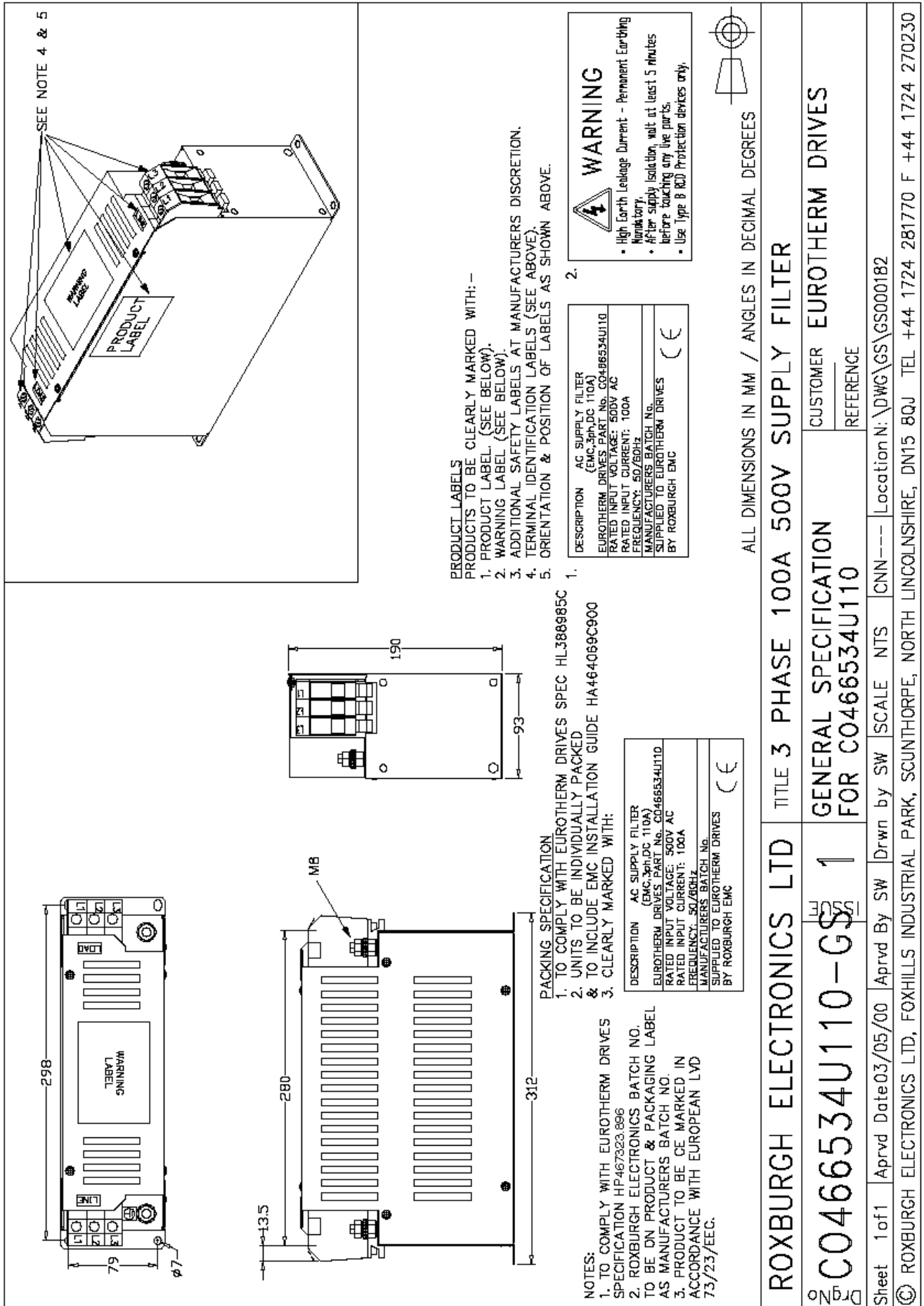

Figure 3-24 Filter Mounting Details, Part No. CO466534U110 for 590+ Frame 2 : 110 Amp

3-46 Installing the Converter

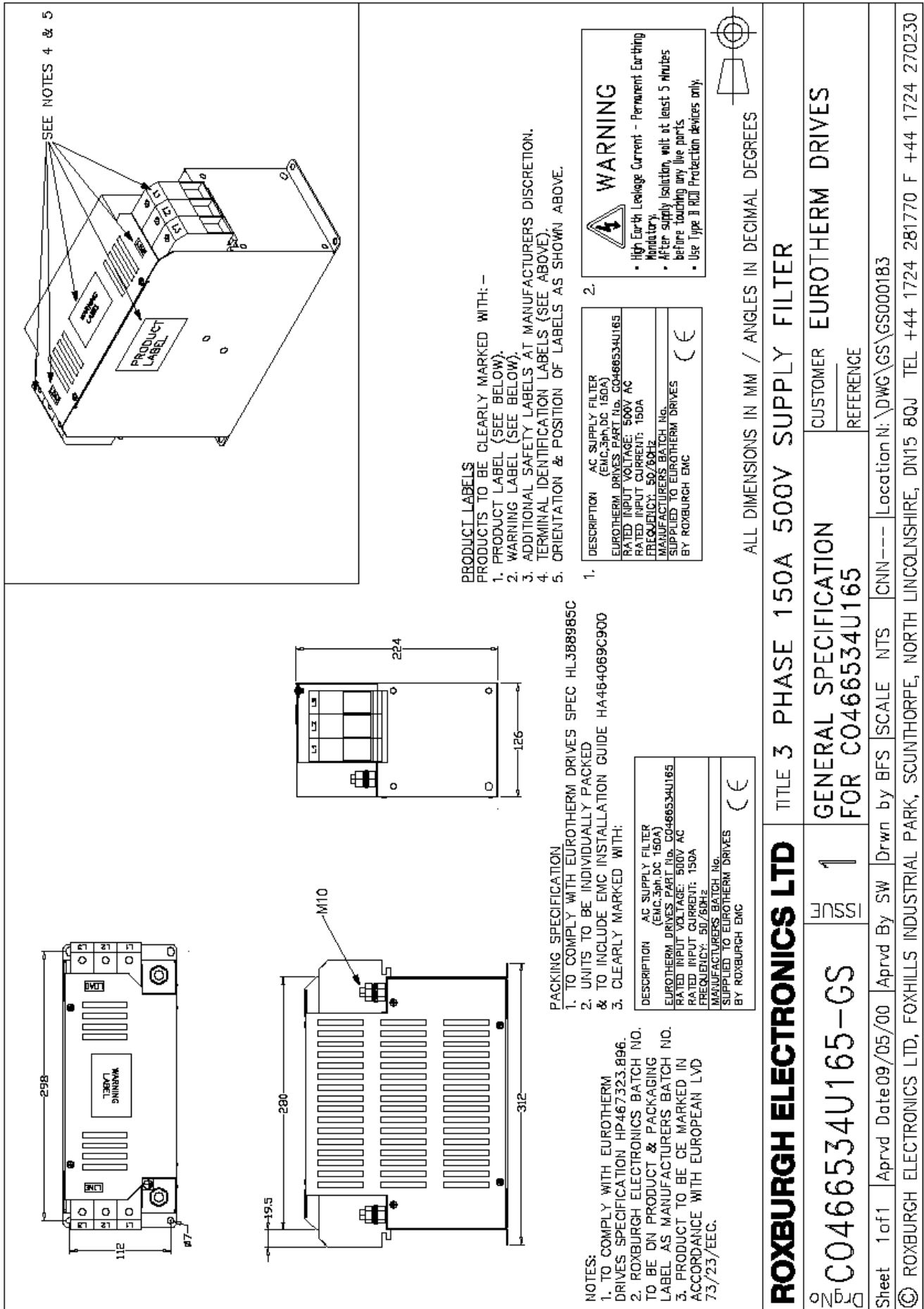

Figure 3-25 Filter Mounting Details, Part No. CO466534U165 for Frame 2 : 165 Amp

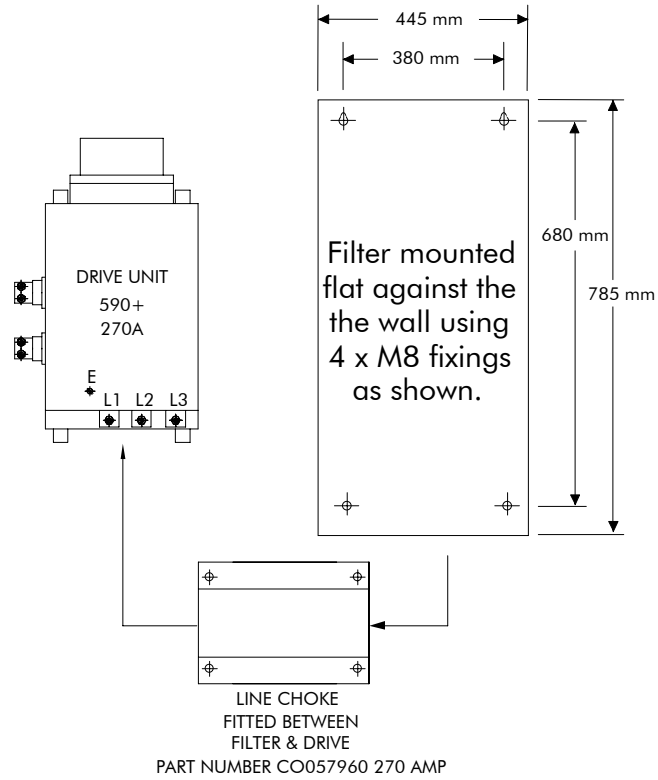

Figure 3-26 Filter Mounting Details, Part No. CO389456 for Frame 3 : 270 Amp

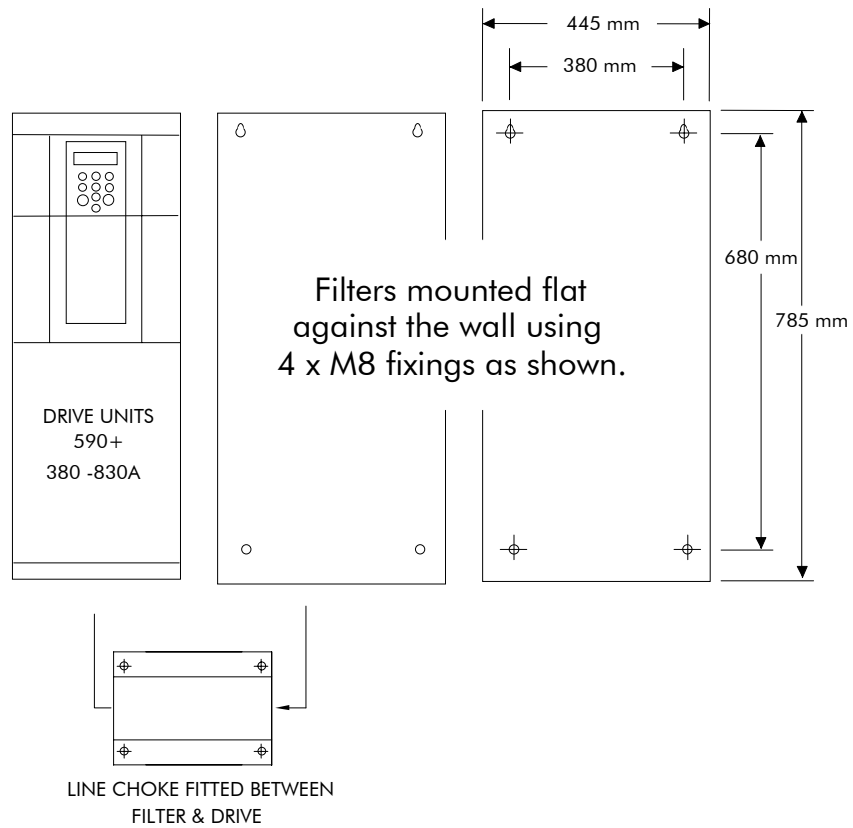
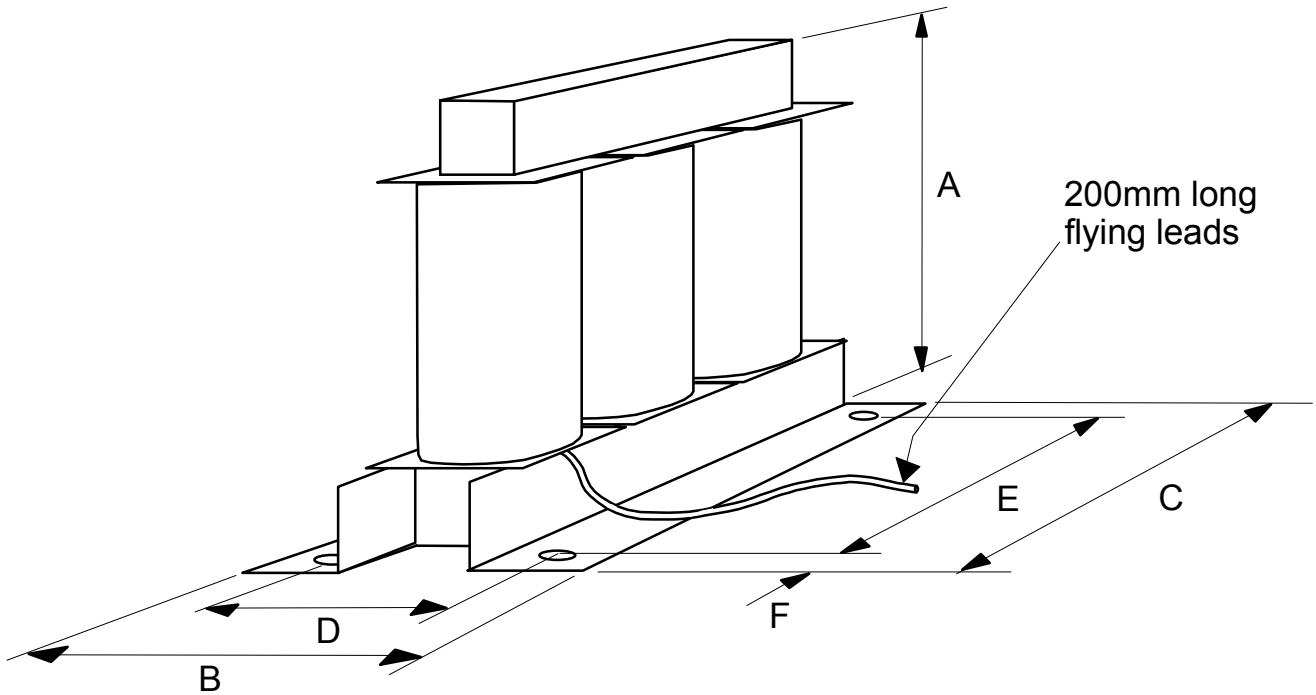

Figure 3-27 Filter Mounting Details using Part No. CO389456 for Frame 4 : 380-830 Amp (refer to Chapter 11: “Technical Specifications” - External AC Supply (RFI) Filters)

3-48 Installing the Converter

Line Choke Installation Drawings

IMPORTANT: Always use the specified ac line choke with the Converter.



Eurotherm Part Number	Converter Rating	Weight (kg)	Dimensions (mm)						Mtg Hole Ø	Terminal Ø
			A	B	C	D	E	F		
For use without EMC Filters										
Frame 1										
CO466448U015	15A	1	67	60	80	40	64	8	7	M8
CO466448U040	35A	2.5	127	70	155	48	140	7.5	7	M8
Frame 2										
CO466448U040	40A	2.5	127	70	155	48	140	7.5	7	M8
CO466448U070	70A	4.5	127	85	155	63	140	7.5	7	M8
CO466448U110	110A	7.5	160	100	190	75	170	10	9	M8
CO466448U165	165A	7.5	160	102	190	76	170	10	9	M8
For use with EMC filters										
Frame 1										
CO466449U015	15A	4.5	127	90	155	68	140	7.5	7	M8
CO466449U040	35A	8	160	100	190	75	170	10	9	M8
Frame 2										
CO466449U040	40A	8	160	100	190	75	170	10	9	M8
CO466449U070	70A	10	160	105	190	83	170	10	9	M8
CO466449U110	110A	14	160	125	190	103	170	10	9	M8
CO466449U165	165A	28	225	200	240	176	150	45	15	M8

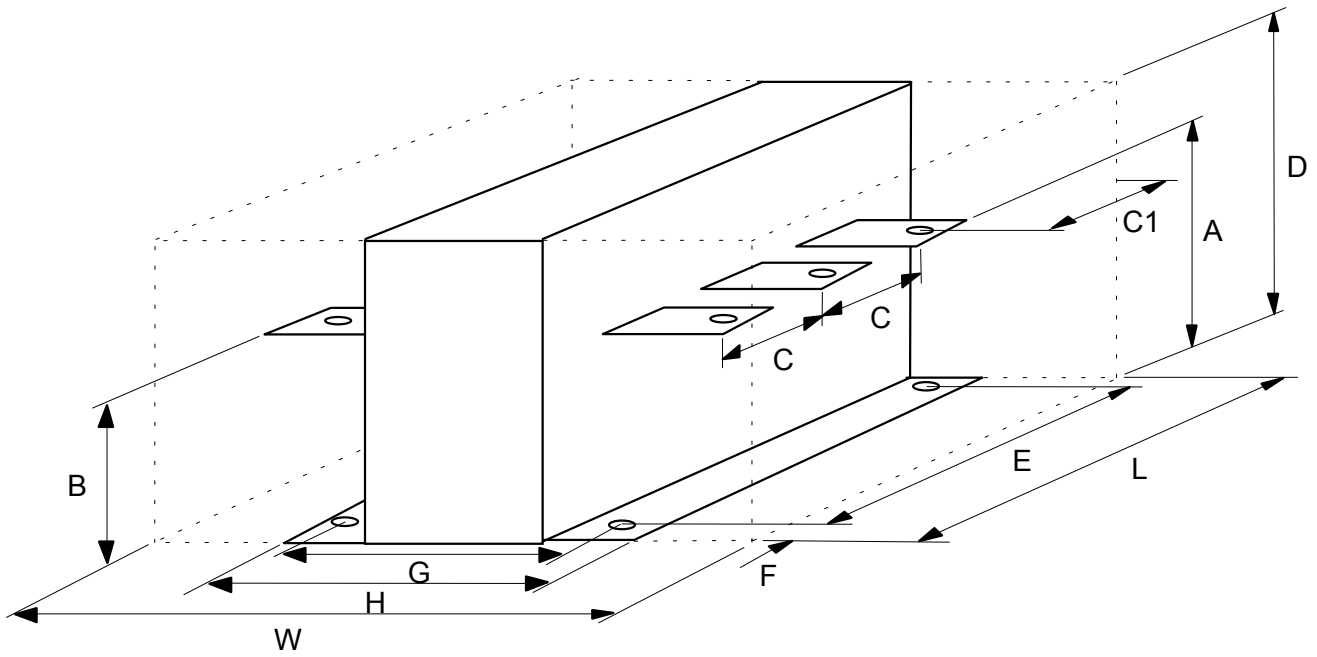

Eurotherm Part Number	Converter Rating	Dimensions (mm)											Mtg Hole Ø	Terminal Ø
		A	B	C	C1	D	E	F	G	H	L	W		
For use without EMC Filters														
Frame 3														
CO057960	270A	110	110	80	60	255	200	40	170	200	280	380	Ø13	M8

Line Choke (Frames 4, 5 & H)

Contact Eurotherm Drives about suitable chokes for the above frame sizes.
 Also refer to Chapter 11: "Technical Specifications" - AC Line Choke (Frame H).

3-50 Installing the Converter

OPERATING THE CONVERTER

Pre-Operation Checks

Initial checks before applying power:

- Mains power supply voltage is correct.
- Auxiliary power supply voltage is correct.
- Motor is of correct armature voltage and current rating.
- Check all external wiring circuits - power, control, motor and earth connections.

Note: *Completely disconnect the Converter before point-to-point checking with a buzzer, or when checking insulation with a Megger.*

- Check for damage to equipment.
- Check for loose ends, clippings, drilling swarf etc. lodged in the Converter and system.
- If possible check that the motor can be turned freely, and that any cooling fans are intact and free from obstruction.

Ensure the safety of the complete system before the Converter is energised:

- Ensure that rotation of the motor in either direction will not cause damage.
- Ensure that nobody else is working on another part of the system which will be affected by powering up.
- Ensure that other equipment will not be adversely affected by powering up.

Prepare to energise the Converter and system as follows:

- Remove the main external HRC fuses to prevent the main 3-phase and single phase auxiliary supply from being connected.
- Disconnect the load from the motor shaft, if possible.
- If any of the Converter's control terminals are not being used, check whether these unused terminals need to be tied high or low. Refer to Chapter 11: "Technical Specifications"- Control Terminals.
- If there is any doubt about the integrity of a particular installation, insert a high wattage resistor, i.e. fire elements, in series with the motor armature.
- Check external run contacts are open.
- Check external speed setpoints are all zero.

4-2 Operating the Converter

Control Philosophy

There are four ways to control the Converter using Remote and Local control:

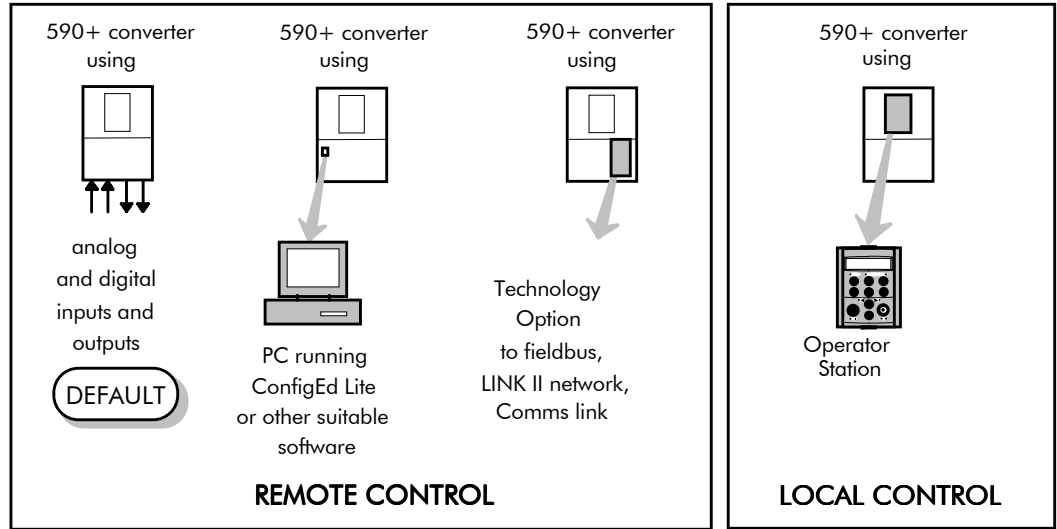

Figure 4-1 Remote and Local Control Modes

Start/Stop and Speed Control

There are two forms of control in operation at any time: *Start/Stop* and *Speed Control*. Each can be individually selected to be under either Local or Remote Control.

- **Local or Remote Start/Stop** decides how you will start and stop the Converter.
- **Local or Remote Speed Control** determines how you will control the motor speed.

In each case, Local and Remote control are offered by using the following:

Local: The Operator Station

Remote: Analog and digital inputs and outputs, System Port P3 or the Technology Option

Thus the Converter can operate in two modes:

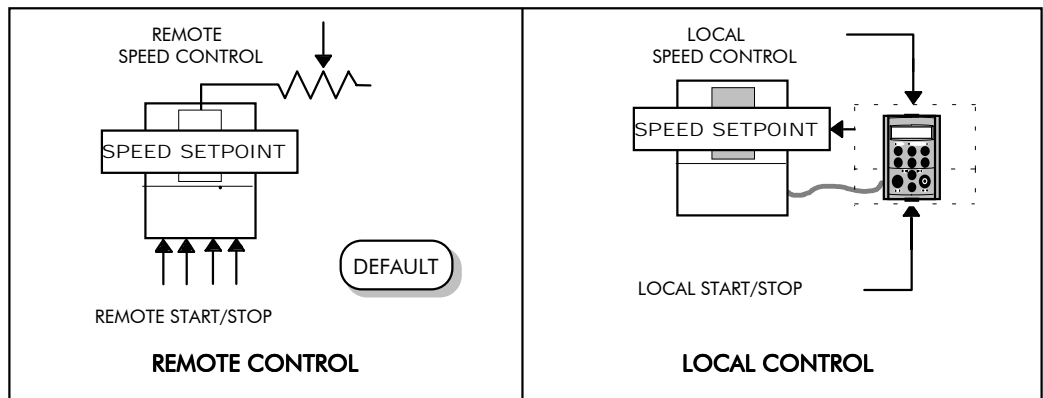

Figure 4-2 Local and Remote Control

Note: *Start/Stop* is also known as "Sequencing".
Speed Control is also known as "Reference Generation".

Selecting Local or Remote Control

DEFAULT

The default is for the L/R key to be set for Remote control, i.e. both the SEQ and REF LEDs will be off.

If the default Remote Start/Stop and Speed Control is not suitable for your application, follow the instructions below using the Operator Station or a suitable PC programming tool to select Local Start/Stop and Speed Control.

Note: You can only change between Local and Remote control when the Converter is “stopped”.

The L/R key on the Operator Station toggles between **Local** and **Remote** control, changing both Start/Stop and Speed Control modes at the same time.

LED Indications

The mode of control is indicated by the “LOCAL” LEDs on the Operator Station:

SEQ = Start/Stop
REF = Speed Control

If the LED is illuminated (●), then LOCAL mode is in force.

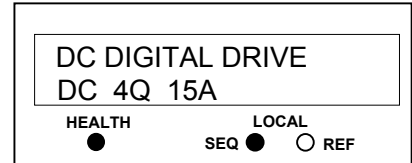

Figure 4-3 Control Mode LED Indications

Reading the Status LEDs

These LEDs are used when the blanking cover is fitted to the drive instead of the Operator Station.

- OFF
- SHORT FLASH
- EQUALFLASH
- LONG FLASH
- ON

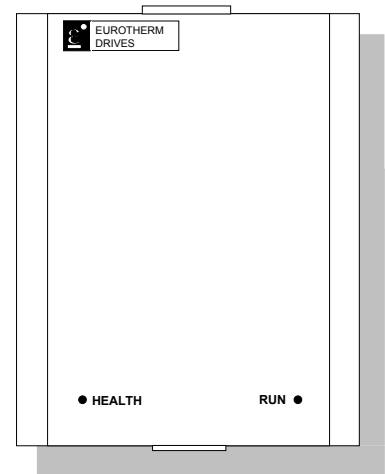

Figure 4-4 Blank Cover showing LEDs

HEALTH	RUN	Converter State
<input type="checkbox"/> <input checked="" type="checkbox"/>	<input type="checkbox"/> <input checked="" type="checkbox"/>	Re-Configuration, or corrupted non-volatile memory at power-up
<input type="checkbox"/> <input checked="" type="checkbox"/>	<input type="checkbox"/>	Tripped
<input type="checkbox"/> <input checked="" type="checkbox"/>	<input type="checkbox"/> <input checked="" type="checkbox"/>	Auto Restarting
<input checked="" type="checkbox"/>	<input type="checkbox"/>	Stopped
<input checked="" type="checkbox"/>	<input checked="" type="checkbox"/> <input type="checkbox"/>	Running with zero reference
<input checked="" type="checkbox"/>	<input checked="" type="checkbox"/>	Running
<input checked="" type="checkbox"/>	<input type="checkbox"/> <input checked="" type="checkbox"/>	Stopping

Table 4-1 Status indications given by the Health and Run LEDs

4-4 Operating the Converter

Setting-up the Converter

The following start-up routine assumes that the Operator Station is fitted and is in default mode, and that the Converter's control terminals are wired as shown in Figure 3-4 - Minimum Connection Requirements.

The following instructions are written in logical order. Complete each stage successfully before progressing to the next.

Preliminaries

Analog Tacho Calibration Option Board

NO POWER IS CONNECTED AT THIS STAGE

Note: This option is not required if armature voltage or encoder feedback is to be used.

The board plugs into the front of the drive. It also requires the connecting link wire to the control board. This link is inherent but must be connected for operation.

The board supports AC and DC analog tachos with a calibration range of 10 to 200V:

- For AC tacho feedback, use terminals G1 and G2 with the selector switch in the AC position.
- For DC tacho feedback, use terminals G3 and G4 with the selector switch in the DC position.

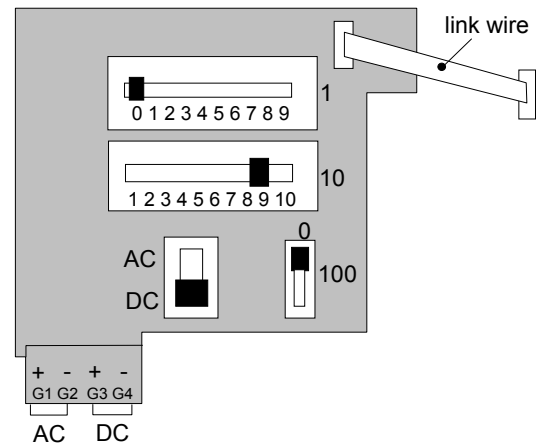

Calculate the tacho voltage by multiplying the required maximum speed by the tacho calibration factor, e.g. motor speed 1500 rpm and tacho calibration factor 60V per 1000 rpm is 90V.

The tacho calibration volts are set using the 2 in-line switches (10-way). The switches set Volts in units and tens. The hundreds are set by the 1-way switch. The illustration above shows a setting of 90V. When setting switches for AC tachos, calibrate the switches for $\sqrt{2}$ x voltage feedback required, i.e. $\sqrt{2} \times 90V = 127V$. This adjusts the rms value received from an AC tacho into the required peak value.

Note: Do not set the calibration volts to greater than 200V, the maximum terminal block rating.

Calibration for Voltages greater than 200V

For full speed tacho voltages greater than 200V, an external resistor, value RE, is required in series with the tachogenerator connection to terminal G3.

Set the switches on the Tacho Calibration Option Board to give a value of 200V, as shown opposite.

RE then is given by the formula:

$$RE = \frac{(\text{tachovolts} - 200)}{5} \text{ k}\Omega$$

The power dissipation of this resistor is given by the formula

$$W = (\text{tacho volts} - 200) \times 5 \text{ milliwatts}$$

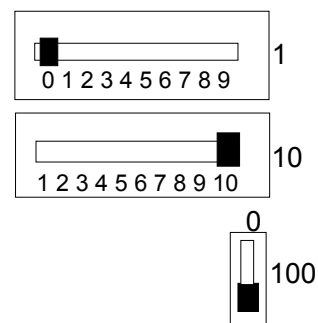

Microtach/Encoder Feedback Option Board

The option board assumes a 1000 lines per rev encoder is being used. Speed is set directly by the ENCODER RPM parameter. If you are using an alternative lines per rev encoder, you must set the ENCODER LINES parameter on the Operator Station later in the Operating Instructions.

Note the CONFIGURE DRIVE menu at the top of the menu tree which contains many of the important parameters used during set-up.

Refer to Chapter 5: "The Operator Station" to familiarise yourself with the Operator Station's LED indications, and how to use the keys and menu structure.

Calibration

AUXILIARY POWER ONLY IS CONNECTED AT THIS STAGE

Connect the auxiliary power supply to auxiliary supply terminals L & N (but do not connect the main 3-phase power supply at this stage). Check that the correct voltage appears between these terminals.

The Operator Station will now display the Welcome screen, and the Health and Overcurrent Trip Operator Station LEDs will be illuminated (assuming that the Converter's control terminals are wired as shown in Figure 3-4, Minimum Connection Requirements).

You must first calibrate the Converter for use with the motor.

IMPORTANT: You must not exceed the maximum drive and motor ratings. Refer to the Product Code or maximum rating label, and the motor rating plate.

Set the following parameters, but first select CONFIGURE ENABLE to be ENABLED.

MMI Menu Map

- 1 CONFIGURE DRIVE
 - CONFIGURE ENABLE
 - NOM MOTOR VOLTS
 - ARMATURE CURRENT
 - FIELD CURRENT
 - ZERO CAL INPUTS
 - FLD.CTRL MODE
 - FLD.VOLTS RATIO
 - CUR.LIMIT/SCALER
 - AUTOTUNE
 - SPEED FBK SELECT
 - ENCODER LINES
 - ENCODER RPM
 - ENCODER SIGN
 - SPD.INT.TIME
 - SPD.PROP.GAIN

FLD.CTRL MODE

Set the field control mode to Field Voltage or Field Current control. Refer to Chapter 6: "Programming Your Application" - Field Control for further information. By default, the drive is operating in Voltage Control mode.

FLD.VOLTS RATIO

Enter the calculated ratio into the parameter given by the equation:
The default setting of 90% is the maximum value obtainable,
i.e. field output = 0.9 x Vac

$$100 \times \frac{\text{FIELD VOLTS}}{\text{RMS AC INPUT VOLTS}}$$

Calibrating for Frames 1 & 2

AUXILIARY POWER ONLY IS CONNECTED AT THIS STAGE

NOM MOTOR VOLTS – Armature Voltage (VACAL)

If the drive's nominal power supply voltage is 220V, set DOUBLE the Armature Voltage value in the Configure Drive menu.

OR

If the drive's nominal power supply voltage is 500V, set the Armature Voltage value in the Configure Drive menu.

MMI Menu Map

- 1 CONFIGURE DRIVE
 - NOM MOTOR VOLTS

ARMATURE CURRENT (IA CAL)

Note the maximum armature current from the motor rating plate and set this value in the ARMATURE CURRENT parameter.

MMI Menu Map

- 1 CONFIGURE DRIVE
 - ARMATURE CURRENT

FIELD CURRENT (IF CAL)

Note the nominal field current from the motor rating plate and set this value in the FIELD CURRENT parameter.

MMI Menu Map

- 1 CONFIGURE DRIVE
 - FIELD CURRENT

4-6 Operating the Converter

Verifying the Power Board Calibration (Frames 4 & 5)

NO POWER IS CONNECTED AT THIS STAGE

With the drive door open, check the switch settings:

IA CAL – Armature Current Calibration Switch (SW1)

This switch is always set to LO on Frame 4 & 5 drives of 500A or less, and HI for drives greater than 500A.

IF CAL – Field Current Calibration Switch (SW2)

This switch should always be set to HI for Frame 4 & 5 drives. The maximum field current calibration is 30A.

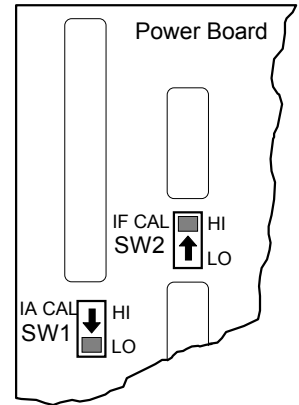

AUXILIARY POWER ONLY IS CONNECTED AT THIS STAGE

NOM MOTOR VOLTS – Armature Voltage (VACAL)

Set the Armature Voltage value in the Configure Drive menu.

MMI Menu Map

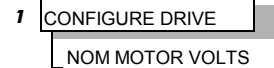

ARMATURE CURRENT (IA CAL)

Note the maximum armature current from the motor rating plate and set this value in the ARMATURE CURRENT parameter.

MMI Menu Map

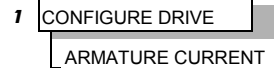

FIELD CURRENT (IF CAL)

Note the nominal field current from the motor rating plate and set this value in the FIELD CURRENT parameter.

MMI Menu Map

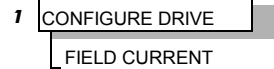

Verifying the Power Board Calibration (Frame H)

IMPORTANT: 590H units require the Calibration Switches on the Power Board to be set to specific positions before use.

AUXILIARY POWER ONLY IS CONNECTED AT THIS STAGE

To access the power board remove the terminal cover, unscrew the two fixings on the right hand side of the control door. Open the door to reveal the power board.

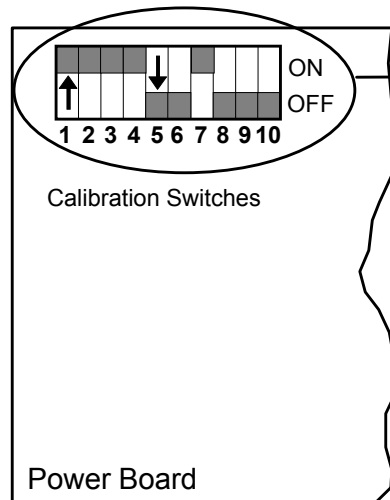

SW1 - 6	Armature Current Calibration	500A stages (factory setting = 2000A)
SW7	Reserved (factory setting = ON)	
SW8 - 9	Field Current Calibration	
	8 9	Field Current Range
0 = OFF	0 0	up to 20A (factory setting)
1 = ON	0 1	up to 40A
	1 0	up to 60A
	1 1	up to 80A (not required on standard build)
SW10	Armature Voltage Calibration	
	OFF = VA / 100 (for VA up to 875V) (factory setting)	
	ON = VA / 200 (for VA greater than 875V)	

Figure 4-1 Calibration Switches

Field Current (IF CAL)

1. Set the Field Current calibration switches 8 and 9 to give the required Field Current range. The drive's Product Code includes the value for Field Current. If you change the Field Current from the 20A factory setting to another value, you must now select the correct Product Code rating:

Note the current Product Code which is displayed on the MMI's Welcome screen at the top of the menu, e.g. DC 4Q 1700A **20** D (**20** = 20A Field Current range)

Now, for instance, if you have set the Field Current range to be 40A, you must select the appropriate Product Code for a Field Current range of 40A, e.g. DC 4Q 1700A **40** D

To do this, refer to Chapter 5: "The Operator Station" – Changing the Stack Size (3-button reset).

2. Note the nominal field current from the motor rating plate and set this value in the FIELD CURRENT parameter.

MMI Menu Map

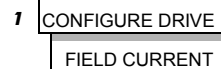

Armature Current (IA CAL)

1. Check that calibration switches 1 to 4 are in the "ON" position, and 5 to 6 are in the "OFF" position. Setting is for 2000A.
2. Note the maximum armature current from the motor rating plate and set this value in the ARMATURE CURRENT parameter.

MMI Menu Map

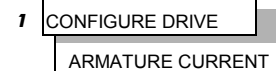

Armature Voltage

If the required Armature Voltage is 525V or less, set SW10 to OFF.

Set the Nominal Motor Voltage value in the Configure Drive menu.

OR

If the required Armature Voltage is greater than 525V, set SW10 to ON.

Set HALF the Nominal Motor Voltage value in the Configure Drive menu.

MMI Menu Map

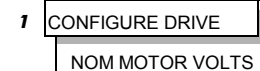

Now select CONFIGURE ENABLE to be DISABLED and perform a PARAMETER SAVE.

Selecting Speed Feedback

AUXILIARY POWER ONLY IS CONNECTED AT THIS STAGE

Use a digital voltmeter to check for the following: (relative to terminal B1)

+24V rail at terminal C9, +10V rail at terminal B3, -10V rail at terminal B4

Using the Operator Station, select the correct speed feedback option.

The default is ARM VOLTS FBK.

The selections are ARM VOLTS FBK, ANALOG TACH, ENCODER and ENCODER/ANALOG.

MMI Menu Map

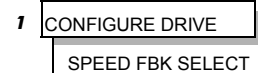

Note: Refer to Chapter 13: "Standard and Optional Equipment" - Speed Feedback Option Boards for further information.

4-8 Operating the Converter

Initial Start-up Routine

Complete steps 1 to 18, including steps 16 and 17 as appropriate.

Note: This routine assumes that the Converter's control terminals are wired as shown in Figure 3-9, Minimum Connection Requirements. The field is "Enabled" and is in Voltage Control (default settings).

IMPORTANT: Do not change any of the previously made calibration settings once the main contactor is energised.

1 Normally, the setpoint ramp input at control terminal A4 is the speed reference source.

Use the Operator Station to display the value of the ANIN 3 (A4). Vary the setpoint potentiometer and observe the input voltage display change.

Additional Setpoint Inputs may also appear at ANIN 1 (A2) and ANIN 2 (A3). Check these if present.

MMI Menu Map

1	DIAGNOSTICS
	ANIN 1 (A2)
	ANIN 2 (A3)
	ANIN 3 (A4)

The sum of all the setpoints is given by the value of the SPEED SETPOINT parameter, and is also output at terminal A8.

MMI Menu Map

1	DIAGNOSTICS
	SPEED SETPOINT

2 Use the Operator Station to check the external current clamp settings (refer to Chapter 6: "Programming Your Application" - ANALOG INPUTS for setting details):

- *If using a single external clamp, C6 low (0V):*

Check that ANIN 5 (A6) is +10V or is adjustable up to +10V.

- *If using dual external clamps, C6 high (+24V):*

Check the ANIN 5 (A6) is at +10V or is adjustable up to +10V and that ANIN 4 (A5) is at -10V or is adjustable up to -10V.

MMI Menu Map

1	DIAGNOSTICS
	ANIN 4 (A5)
	ANIN 5 (A6)

3 If possible, check the speed feedback by rotating the shaft manually in the forward direction.

- *Analog Tachogenerator:*

The voltage at G3 (DC Tach Input) should go positive.

- *MICROTACH/Encoder*

The ENCODER parameter should give a positive reading.

MMI Menu Map

1	DIAGNOSTICS
	TACH INPUT (B2)

MMI Menu Map

1	DIAGNOSTICS
	ENCODER

Also check the SPEED FEEDBACK parameter is reading a positive value. If there is no feedback signal from the Microtach, verify that both LEDs on the Microtach Option Board are illuminated. If either LED is extinguished, check that 24V is applied to the Microtach and all ancillary products, and that the fibre optic transmission length is not exceeded.

MMI Menu Map

1	DIAGNOSTICS
	SPEED FEEDBACK

4 Scroll through the SETUP PARAMETERS menu and take a note of the MAIN CURR. LIMIT parameter's value. You will need this later.

Set the MAIN CURR. LIMIT parameter to 0.00%.

Select the correct setting for the SPEED FBK SELECT.

MMI Menu Map

1	SETUP PARAMETERS
2	CURRENT LOOP
	MAIN CURR. LIMIT

Note: Save any parameters that have been changed. Refer to Chapter 5: "The Operator Station" - How to Save, Restore and Copy your Settings.

MMI Menu Map

1	CONFIGURE DRIVE
	SPEED FBK SELECT

5 With +24V present at terminals B8 and B9 (Program Stop and Coast Stop):

- Apply the "Start/Run" command to C3.

The main 3-phase contactor should pull-in and remain energised, (it may de-energise almost immediately due to the 3-phase fail alarm).

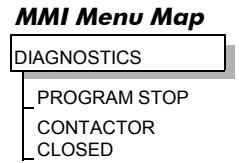

- Remove the "Start/Run" command from C3.

The main 3-phase contactor should drop-out and remain de-energised.

If the above sequence does not function, remove the auxiliary power and check start/stop sequencing and contactor wiring.

If the contactor is left energised for an extended time during this check, the controller will detect that 3-phase is not connected and switch off the contactor, flagging the 3-phase alarm.

The main contactor should never be operated by any means other than the drive internal controls, nor should any additional circuitry be placed around the contactor coil circuit.

WARNING!

Only continue with the set-up instructions if the stop/start circuits and contactor operate correctly.

6 Switch off all power supplies to the equipment and, when the whole system is totally isolated and safe, re-connect the main 3-phase power supply.

- Switch on the auxiliary supply.
- Switch on the main 3-phase supply.

MAIN & AUXILIARY POWER ARE CONNECTED AT THIS STAGE

7 Set the Speed Setpoints to zero so that the value of the SPEED SETPOINT parameter is zero, this is also output at Terminal A8.

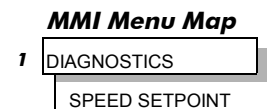

8 Verify that the MAIN CURR. LIMIT is set to 0.00%, or that the ANIN 5 (A6) parameter in the DIAGNOSTICS menu at level 1 is displaying 0.00V.

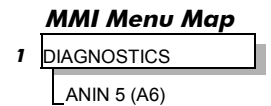
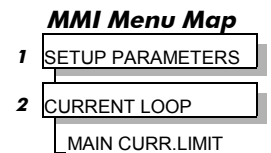

9 Apply the Start/Run command and check that 3-phase mains is applied to Power Terminals L1, L2 and L3. Initiate "Enable" (C5) and immediately check that the correct field voltage appears between the auxiliary supply terminals F+ and F-.

This is high voltage DC, proceed with caution. Do not continue if this is incorrect, switch off all supplies and check connections. Refer to 9.1 or 9.2 on the next page:

4-10 Operating the Converter

If the field voltage is not correct, make the following checks:

9.1 Internally Supplied Field:

- Check that 3-phase is applied to terminals L1, L2 and L3 when the main contactor is closed.
- Check that the coding fuses on the power board or suppression board are healthy.
- The FIELD ENABLE parameter should be set to ENABLE.
- With the FIELD ENABLE parameter in view, press the ↓ (DOWN) key. The display changes to FLD CTRL MODE. Press the **M** key. Is this set to VOLTAGE CONTROL or CURRENT CONTROL?

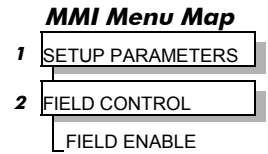

- If set to VOLTAGE CONTROL, check the value of the FLD. VOLTS RATIO parameter. Set this to 65% to obtain 300V fields from 460V lines.
- If set to CURRENT CONTROL, check the field current calibration set-up, refer back to “Calibration”.

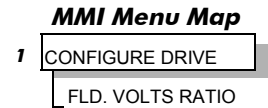

If the field volts are at maximum, check the field continuity. (The field current may initially be lower than the rated value due to a cold field.)

9.2 Externally Supplied Field: (not available on Frame 1 units)

Refer to Chapter 3: “Installing the Converter” - Motor Field Connections for conversion details.

- Check the voltage applied (externally fused) to terminals FL1 and FL2.
- Check the phasing of voltage applied to FL1 and FL2:

FL1 must be connected directly or indirectly to the Red phase on main power terminal L1.

FL2 must be connected directly or indirectly to the Yellow phase on main power terminal L2.

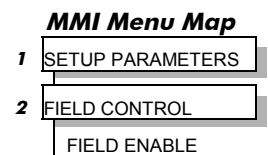

- The FIELD ENABLE should be set to ENABLE.
- With the FIELD ENABLE parameter in view, press the ↓ (DOWN) key. The display changes to FLD CTRL MODE. Press the **M** key. Is this set to VOLTAGE CONTROL or CURRENT CONTROL?

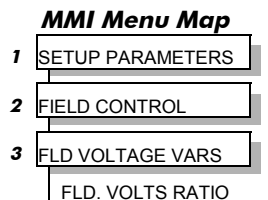

■ If set to VOLTAGE CONTROL, check the value of the FLD. VOLTS RATIO parameter. Set this to 65% to obtain 300V fields from 460V lines.

■ If set to CURRENT CONTROL, check the field current calibration set-up, refer back to “Calibration”.

Check that 3-phase is applied to terminals L1, L2 and L3.

10 Check that the HEALTH and STOP Operator Station LEDs are now illuminated, also either the FWD or REV LED. Note that any external interlocks which affect the Enable input C5 will affect the operation of the drive.

11 If the STANDSTILL LOGIC parameter in the STANDSTILL menu at level 2 is ENABLED, temporarily set it to DISABLED.

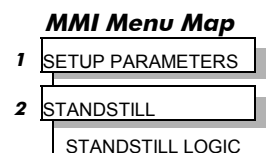

Caution

During the following set-up instructions, be ready to STOP the converter should the motor try to overspeed.

12 Set the Speed Setpoints so that the value of the SPEED SETPOINT is about 5%, 0.5V at setpoint input (terminal A8).

Perform the next operation with ARM VOLTS FBK selected for the SPEED FBK SELECT parameter (because it is hard-wired and therefore the sign will be correct). Select it now.

MMI Menu Map

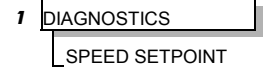

Slowly increase the MAIN CURR.LIMIT parameter up to a maximum of about 20%. The motor should begin to rotate if all connections are made correctly. The motor speed will settle at about 5% of full speed if the motor is unloaded. Check the feedback from the Tacho or Encoder using the appropriate Diagnostic menu.

MMI Menu Map

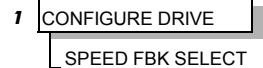

Now stop the drive. Re-instate your selection for the SPEED FBK SELECT parameter (if other than ARM VOLTS FBK) and perform the same test again.

If the test was successful perform a PARAMETER SAVE and go to 14. If just direction of rotation is wrong, go to 13, otherwise check as below.

If 5% speed (approx.) is exceeded and the motor continues to accelerate a reversed connection is implied, decrease the MAIN CURR.LIMIT parameter to zero.

MMI Menu Map

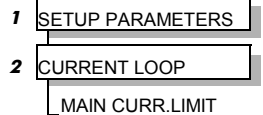

12.1 Reversed Connections - Analog Tachogenerator:

Open the main contactor and switch off all supplies, then correct the connections.

- If the motor is turning in the correct direction, reverse the tachogenerator connections only.
- If the motor is turning in the wrong direction, reverse the field connections only.

12.2 Reversed Connections - MICROTACH/Encoder:

Open the main contactor.

- If the motor is turning in the right direction, change over the ENCODER SIGN parameter.
- If the motor is turning in the wrong direction, switch off all supplies then reverse the field connections only.

MMI Menu Map

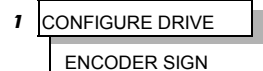

Re-connect the supplies if disconnected and repeat the test from the beginning.

If the motor still runs out of control, check the tachogenerator and the wiring continuity. In the case of the MICROTACH there are two LED's on the MICROTACH option board, both LED's should be ON indicating healthy operation of the wiring and tacho. If in doubt about the operation of the tachogenerator either Analog or MICROTACH during this test, monitor terminal A7 with respect to signal ground on a meter. This will show if a feedback is present.

Note: *If the drive trips on speed feedback alarm with tachogenerator feedback of the correct polarity, check the armature voltage calibration.*

Check the SPEED FBK SELECT. This could be set incorrectly allowing the drive to run open loop.

MMI Menu Map

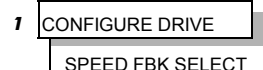

If the motor does not turn at all when the MAIN CURR.LIMIT is increased to 20%, check the CURRENT FEEDBACK parameter to verify that current is flowing into the armature. If no current is flowing, switch off and check the armature connections.

Is the motor connected to the converter?

- Verify that calibration has been carried out correctly.

MMI Menu Map

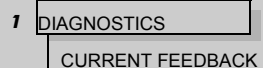

4-12 Operating the Converter

WARNING!

Only continue with the set-up instructions if this test is completed satisfactorily.

13 If the drive has run satisfactorily without any need for reconnection of the field or tachogenerator but the direction of rotation is wrong, open the main contactor and disconnect all supplies.

13.1 *Analog Tachogenerator:*

Reverse both field and tachogenerator connections.

13.2 *MICROTACH/Encoder:*

Reverse the field, re-establish the auxiliary supply and reverse the ENCODER SIGN parameter.

MMI Menu Map

- 1 CONFIGURE DRIVE
 - ENCODER SIGN

IMPORTANT: When satisfactory operation has been achieved, perform a PARAMETER SAVE. Refer to Chapter 5: "The Operator Station" - Saving Your Application.

14 With the MAIN CURR.LIMIT parameter set to 20% or the level required to achieve rotation, set the Speed Setpoints so that the value of the SPEED SETPOINT is about 10%, 1.0V at setpoint input (Terminal A8). The motor will accelerate to this speed setting.

14.1 *4 Quadrant Drives which require reverse rotation:*

Alter the Speed Setpoints so that the value of the SPEED SETPOINT parameter is about -10% and check that motor runs in the reverse direction.

MMI Menu Map

- 1 DIAGNOSTICS
 - SPEED SETPOINT

14.2 *Adjustment of ZERO SPEED OFFSET parameter:*

(Ensure STANDSTILL is DISABLED as in item 11)

■ *4 Quadrant, non-reversing drives*

Set the Speed Setpoint potentiometer to zero and adjust the ZERO SPEED OFFSET parameter for minimum shaft rotation.

MMI Menu Map

- 1 SETUP PARAMETERS
- 2 CALIBRATION
 - ZERO SPD.OFFSET

■ *2 Quadrant, non-reversing drives*

Set the Speed Setpoint potentiometer to zero and adjust the ZERO SPEED OFFSET parameter until the shaft is just rotating then reduce level until the shaft stops.

■ *4 Quadrant, reversing drives*

Set the ZERO SPEED OFFSET parameter to balance maximum speed in forward and reverse directions.

MMI Menu Map

- 1 SETUP PARAMETERS
- 2 STANDSTILL
 - STANDSTILL LOGIC

You can also set the STANDSTILL LOGIC parameter to ENABLE if a stationary shaft is required.

15 Gradually increase the Speed Setpoints so that the value of the SPEED SETPOINT (DIAGNOSTIC menu) is at maximum. Check the shaft speed is correct.

If fine adjustment is required adjust the calibration as appropriate to the speed feedback selection:

- Armature Voltage feedback has a +2/-10% trim, greater changes outside this range require re-setting of the calibration switches.
- Analog Tachogenerator has a +2/-10% trim, greater changes outside this range require re-setting of the calibration switches.
- The MICROTACH/Encoder should give an absolute rotational speed for which adjustment is unnecessary however the motor speed may not be the relevant factor thus speed of rotation can be altered by simply adjusting the calibration.

MMI Menu Map

- 1 SETUP PARAMETERS
- 2 CALIBRATION
 - ARMATURE V CAL.
 - ANALOG TACH CAL.
 - ENCODER RPM

16 Adjustment for field weakening:

If the drive is to be run with a top speed greater than the base speed then 'field weakening' is used to achieve that top speed. (Refer to Chapter 9: "Control Loops" - Field Control for a more detailed explanation.

Note: Note that the drive must be operating in Field Current Control. Select *CURRENT CONTROL* on the *FLD CTRL MODE* parameter. Also, field weakening cannot be used if you have *Armature Voltage feedback* selected.

Run the drive up to base speed and check the motor volts are correct.

In the *FLD WEAK VARS* menu, verify that field weakening is selected (*FIELD WEAK ENABLE*) and that the *MIN FLD CURRENT* parameter is set appropriately. Adjust the maximum armature volts to the required scaled level by setting the *MAX VOLTS* parameter.

Increase the speed above the base speed, checking that the armature volts remain constant whilst the field current reduces.

Gradually increase to maximum speed. Monitor the armature volts at maximum speed and trim the speed using the appropriate control as detailed in Step 15. *PROCEED WITH CARE - MAKE SMALL ADJUSTMENTS.*

Trim the *MIN FLD CURRENT* parameter to the appropriate setting (5% lower than the field current at full speed).

IR COMPENSATION (*CALIBRATION* function block) is also used in field weakening applications to improve dynamic response and speed holding stability.

To set up *IR COMPENSATION*:

Set *FIELD ENABLE* to *DISABLED* (*FIELD CONTROL* function block). Start the drive with a 5% speed demand and ensure the *ACTUAL POS I LIMIT* is 100% (diagnostic). This should stall the drive at zero speed and cause it to pass 100% current. Monitor the *BACK EMF* diagnostic and note the value (typically anything up to 17% is normal). Stop the drive and enter this value into *IR COMPENSATION* and repeat the test to ensure that *BACK EMF* then reads zero.

MMI Menu Map

- 1 CONFIGURE DRIVE
 - FLD CTRL MODE

MMI Menu Map

- 1 SETUP PARAMETERS
- 2 FIELD CONTROL
- 3 FLD CURRENT VARS
- 4 FLD WEAK VARS
 - FLD. WEAK ENABLE
 - MIN FLD CURRENT
 - MAX VOLTS

17 Adjustment for reversing drives:

For reversing drives, check the maximum reverse speed.

Imbalance in reversing drives can only be corrected by adjusting the *ZERO SPD OFFSET* parameter, which may be to the detriment of operation at Zero Setpoint.

MMI Menu Map

- 1 SETUP PARAMETERS
- 2 CALIBRATION
 - ZERO SPD.OFFSET

18 Re-set the *MAIN CURR. LIMIT* parameter to the original setting that you previously noted. If in doubt, set it to 100% to correspond to 100% full load current (FLC).

Note: The controller cannot achieve 200% current unless the *CUR. LIMIT/SCALER* parameter is increased to 200% (from its default setting of 100%). Until this is done, the *External Current Clamp* will limit the current to 100%, refer to Chapter 6: "Programming Your Application" - *CURRENT LOOP*.

MMI Menu Map

- 1 SETUP PARAMETERS
- 2 CURRENT LOOP
 - MAIN CURR.LIMIT

- If the current limit is set higher (maximum 200%) and the motor runs into an overload condition, the current is automatically reduced from the current limit level down to 103% FLC (continual rating).
- If the motor is overloaded, the controller will reduce the current to 103% of the current calibration. (If the motor continues to rotate it may overheat and thermal protection should be provided).
- If the motor is overloaded and the current provided by the controller is not enough to maintain rotation, i.e. it stalls, the controller will trip out showing *STALL TRIP* alarm, if enabled.

4-14 Operating the Converter

Performance Adjustment

Current Loop - The Autotune Feature

Now perform an Autotune to identify and store the following Current Loop parameters:

PROP. GAIN
INT. GAIN
DISCONTINUOUS

Initial Conditions

1. Main contactor open, i.e. no Start/Run signal at terminal C3.
2. Set the AUTOTUNE parameter to OFF.
3. Program Stop (terminal B8) and Coast Stop (terminal B9) should be high, i.e. 24V.
4. If the field is being supplied by a third-party controller, remove the field manually. (If the field is internally regulated, Autotune automatically quenches the field).

Note: *The shaft may require clamping for certain motors to prevent rotation >20% during the Autotune sequence. If using a permanent magnet motor, the shaft MUST be clamped.*

Performing an Autotune

- Set the AUTOTUNE parameter to ON.
- Close the main contactor, i.e. Start/Run signal to terminal C3.
- Energise the Enable terminal (C5).

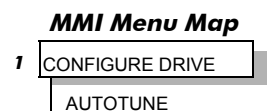

The Autotune sequence is initiated. When complete (after approximately 10 seconds), the main contactor is opened automatically signalling the end of the sequence and the AUTOTUNE parameter is reset to OFF.

- **Perform a PARAMETER SAVE now.** Refer to Chapter 5: “The Operator Station - Saving Your Application.
- If necessary, restore field connections and remove the mechanical clamp.

Autotune Failed?

- The Operator Station displays the message AUTOTUNE ABORTED
If any one of the Initial Conditions above are removed, or the Autotune sequence times out (after 2 minutes), then the Autotune sequence is aborted causing the main contactor to drop out.
- The Operator Station displays the message AUTOTUNE ERROR
If during the Autotune sequence the motor speed feedback is greater than 20% of rated speed, or the field current is detected above 6% of rated field current, then the Autotune sequence is suspended causing the main contactor to drop out.

Note: *Refer to Chapter 9: “Control Loops” - Current Control for manual tuning instructions.*

Speed Loop

You will need to adjust the Speed Loop for your particular application although in most cases the default settings are acceptable.

The optimum Speed Loop performance is achieved by adjusting the PROP. GAIN and INT. TIME CONST. parameters.

Produce a small step-change to the speed setpoint and observe the response on the tachogenerator feedback. If the Converter is using Microtach/Encoder feedback, then the speed response can be monitored on Terminal A7.

Adjust the two parameters until you have rapid change of speed feedback between the setpoint values, but with minimum overshoot.

Incorrect Speed Response

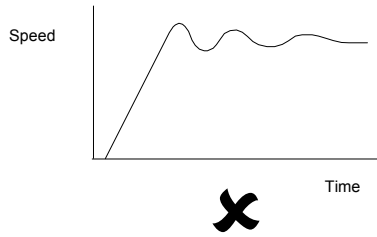

Under damped response causing overshoot or 'ringing'

Incorrect Speed Response

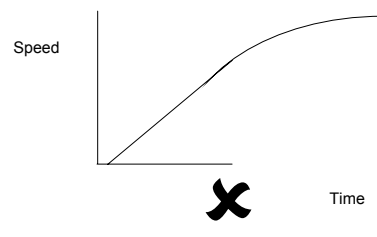

Over damped response takes a long time to reach Steady State

Correct Response

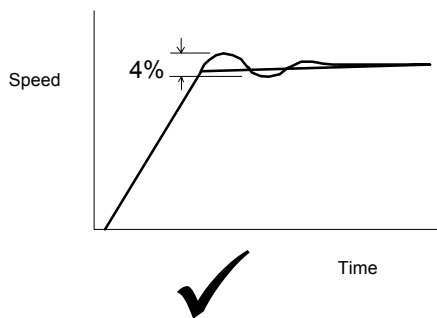

Critically Damped Response with no more than 4% of maximum speed from first overshoot to first undershoot

Starting and Stopping Methods

Stopping Methods

Note:

- If the Converter is “non-regenerative” (2-quad - 591+) it effectively coasts to a stop once the current demand reverses.
- If the Converter is “regenerative” (4-quad - 590+) then it can stop faster because it uses energy from the load, i.e. reverse current is allowed to flow.

Normal Stop and Program Stop are only relevant for a “regenerative” controller.

The parameters STOP TIME and PROG STOP TIME have associated timers which initiate a Coast Stop after the timed period.

The Coast Stop has direct control of the Run relay with no intervening electronics.

All associated parameters can be found in the STOP RATES menu.

MMI Menu Map

1	SETUP PARAMETERS
2	STOP RATES

Terminal	Description	Function	Parameter	Priority
B9	Coast Stop	Motor coasts to rest	--	Overrides Program Stop and Normal Stop
B8	Program Stop	Motor decelerates at Program Stop rate	PROG STOP TIME	Overrides Normal Stop
C3	Start/Run (Normal Stop)	Motor decelerates at Normal Stop rate	STOP TIME	--

4-16 Operating the Converter

Normal Stop (C3)

This is achieved by removing 24V from Terminal C3.

The motor speed is brought to zero in a time defined by the STOP TIME parameter.

MMI Menu Map

- 1 SETUP PARAMETERS
- 2 STOP RATES
- STOP TIME

NORMAL STOP

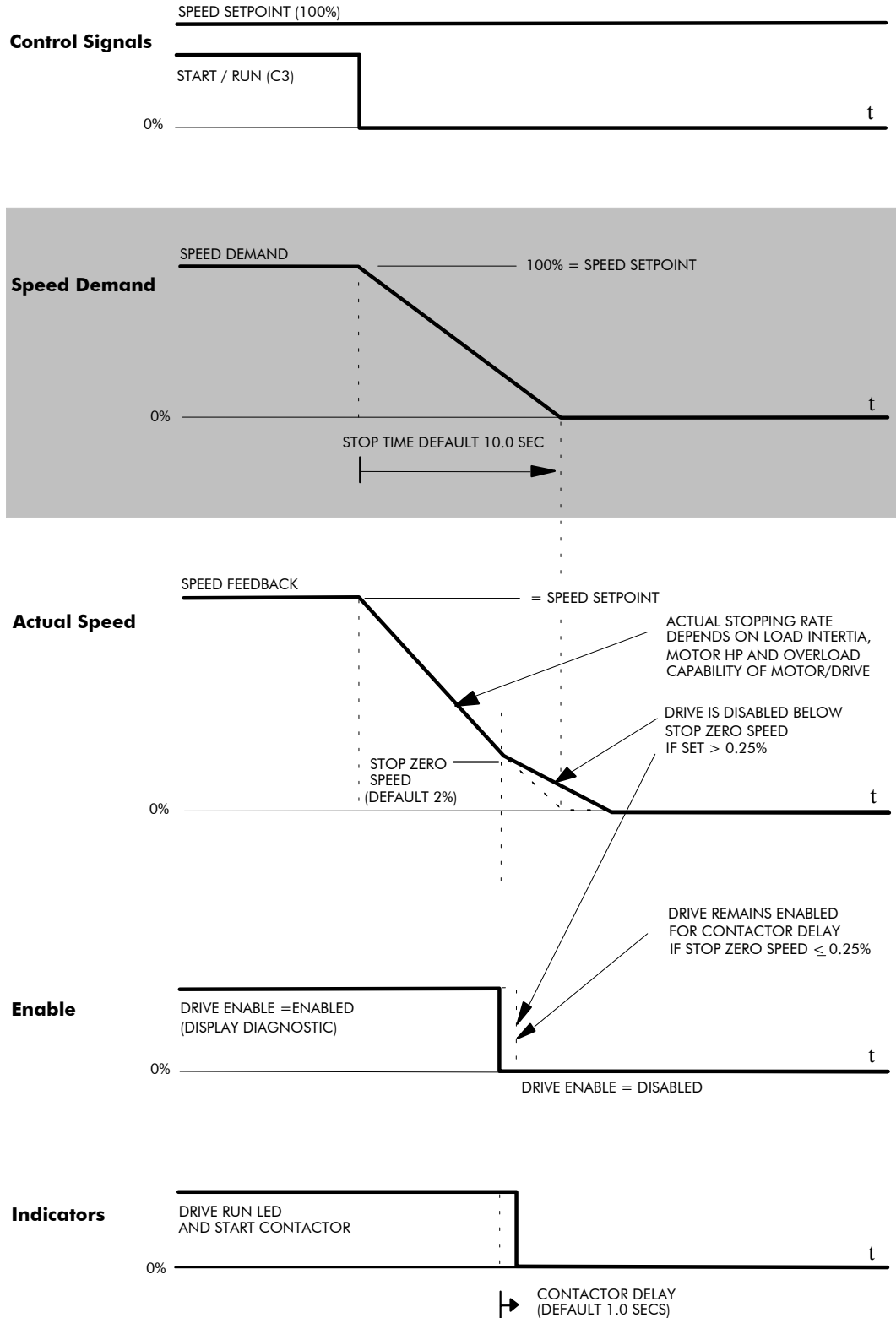

TIME-OUT IN NORMAL STOP

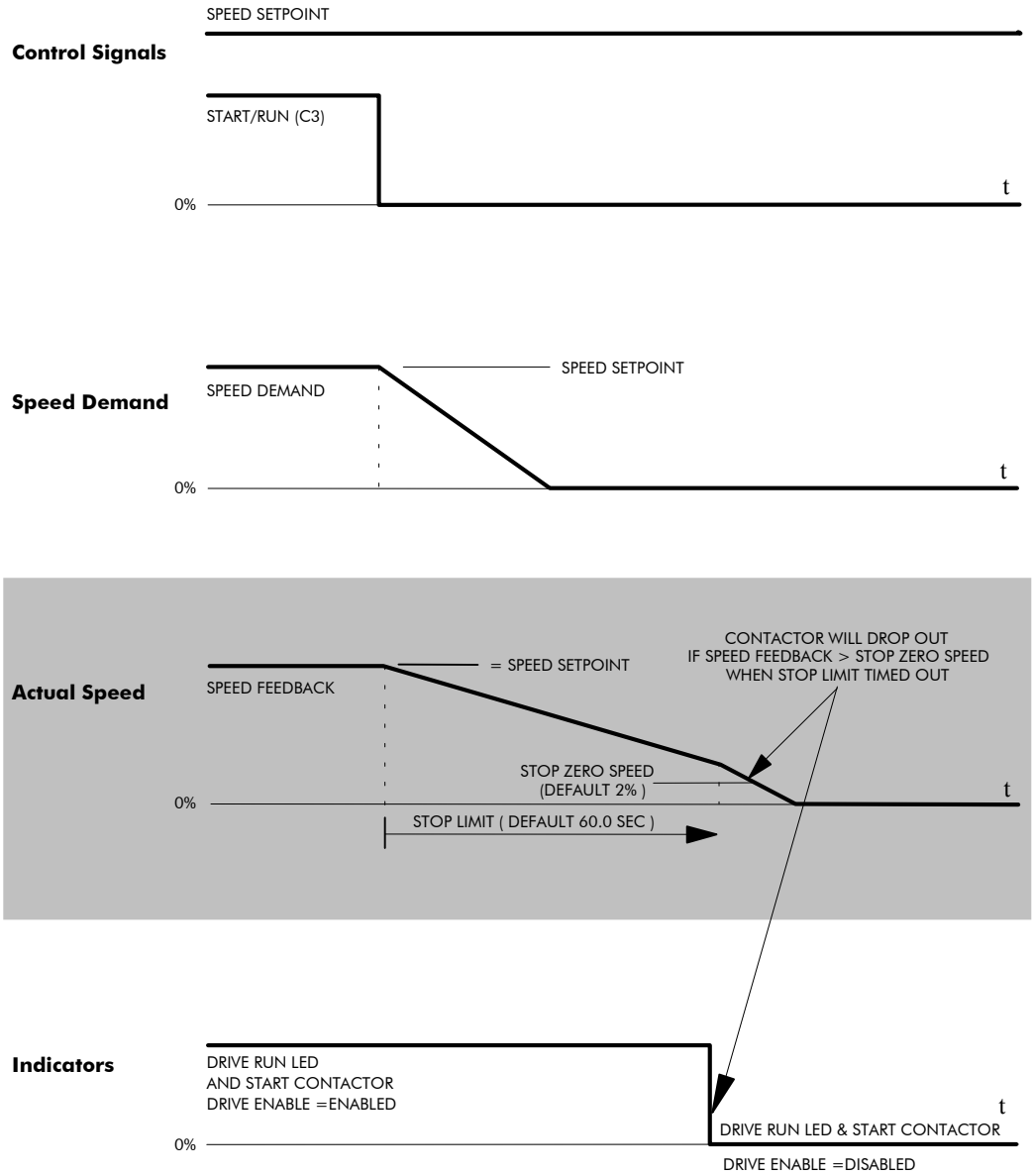

4-18 Operating the Converter

Program Stop (B8)

This is achieved by removing 24V from Terminal B8.

The motor speed is brought to zero under conditions defined by the PROG. STOP TIME (ramp rate) and PROG. STOP I LIMIT parameters.

MMI Menu Map

- 1 SETUP PARAMETERS
- 2 STOP RATES
 - PROG. STOP TIME
 - PROG. STOP I LIMIT

PROGRAM STOP TIMING

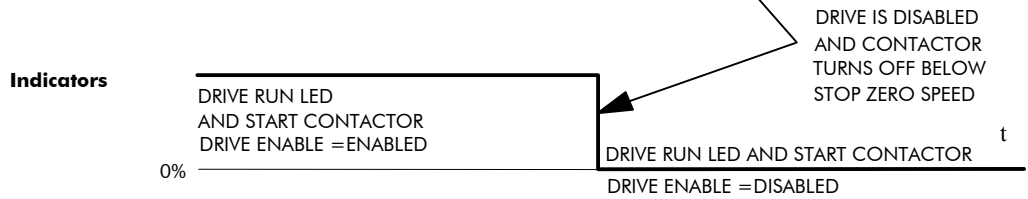
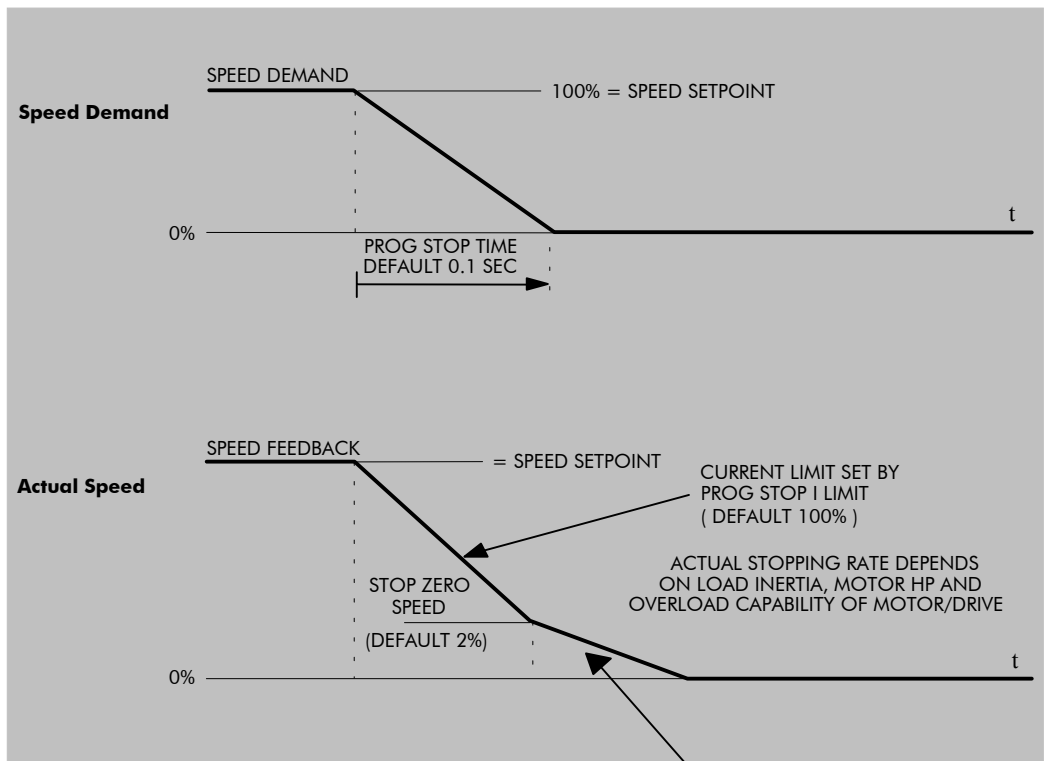
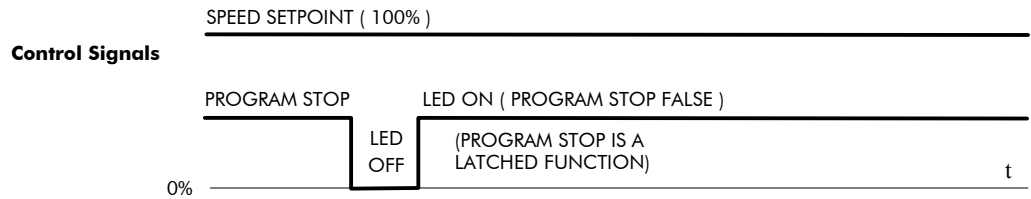

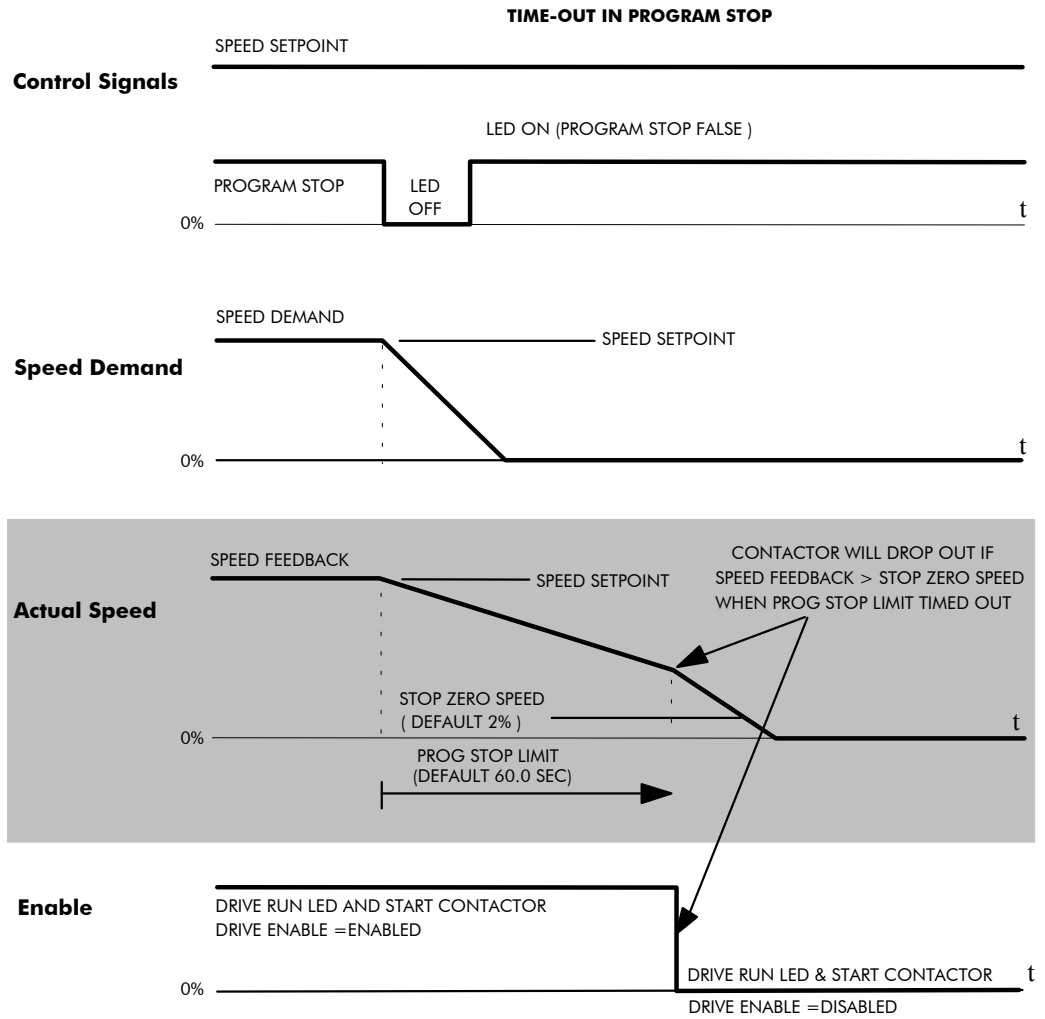

Coast Stop (B9)

This is achieved by removing 24V from Terminal B9.

The stack is automatically quenched and the contactor is opened. The motor coasts to a stop.

Note: The motor coast stop rate is dictated by the motor inertia - the drive does not control the motion.

Standstill

Refer to Chapter 6: “Programming Your Application” - STANDSTILL.

MMI Menu Map

- 1 SETUP PARAMETERS
- 2 STANDSTILL
 - STANDSTILL LOGIC
 - ZERO THRESHOLD

The Trip Condition

When a trip condition is detected, a similar stopping method to Coast Stop is used. The power stack cannot be re-enabled until the trip condition has been cleared and successfully reset. Refer to Chapter 7: “Trips and Fault Finding” for further details.

4-20 Operating the Converter

Normal Starting Method

To achieve a normal start of the Converter:

1. Apply 24V to Terminal C5 (Enable)
2. Apply 24V to Terminal C3 (Start)

Note: *The Converter will not start if there are alarms present, or if Terminals B8 (Program Stop) or B9 (Coast Stop) are low, 0V.*

Ensure that Program Stop and Coast Stop are valid before Start/Run is applied.

Advanced Starting Methods

Starting Several Converters Simultaneously

1. Apply 24V to Terminal C3 (Start)
2. Use Terminal C5 (Enable) to synchronise the start-up of the Converters

Jog

1. Apply 24V to Terminal C5 (Enable)
2. Apply 24V to Terminal C4 (Jog Mode)

Note: *The Converter will not start if there are alarms present.*

The Converter can be started using JOG SPEED 1, JOG SPEED 2 (allowing for two different setpoints, or perhaps to provide an Inch Forward/Inch Reverse).

Refer to Chapter 6: “Programming Your Application” - JOG/SLACK for further information. Also refer to the STOP RATES function block: the CONTACTOR DELAY parameter is used to prevent multiple operations of the main contactor from rapid use of the Jog switch.

Crawl

1. Apply 24V to Terminal C3 (Start)
2. Apply 24V to Terminal C4 (Jog Mode)

Note: *The Converter will not start if there are alarms present.*

Start the Converter using a crawl speed, in Forward or Reverse.

Refer to Chapter 6: “Programming Your Application” - JOG/SLACK for further information.

THE OPERATOR STATION

Connecting the Operator Station

The Operator Station is a plug-in MMI (Man-Machine Interface) option that allows full use of the Converter's features.

It provides local control of the Converter, monitoring, and complete access for application programming.

Insert the Operator Station into the front of the Converter (replacing the blank cover and plugging into the RS232 programming port); or mount it up to 3 metres away using the optional panel mounting kit with connecting lead. Refer to Chapter 3: "Installing the Converter" - Fitting the Remote 6901 Operator Station.

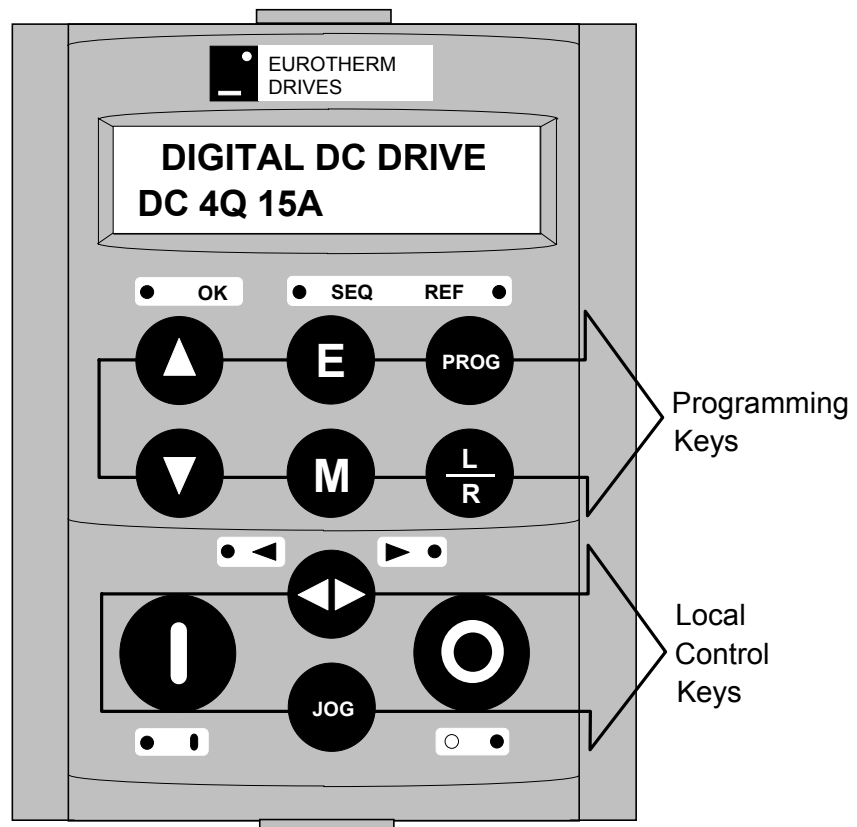

Figure 5-1 Operator Station displaying Welcome screen

Controlling the Operator Station

On power-up, a calibration message is displayed. This is quickly replaced by a default Welcome screen showing the product description and Product Code (an example code is shown in the figure above). This screen is at the top of the menu system.

The drive can operate in one of two modes:

Remote Control Mode: Allowing complete access for application programming

Local Control Mode: Providing local control and monitoring of the drive

Local control keys are inactive when Remote control mode is selected and vice versa, with one exception; the L/R key toggles Local or Remote control modes and so is always operative.







The drive always initialises in Remote control mode, and with the Local control keys inactive, it is unlikely that the motor could be started accidentally.

5-2 The Operator Station





Control Key Definitions

Keys for Programming the Converter

Note: See "Navigating the Menu", page 5-6 for a quick-start to using the menu.

<p>UP</p> 	<p><i>Navigation</i> - Moves upwards through the list of parameters.</p> <p><i>Parameter</i> - Increments the value of the displayed parameter.</p> <p><i>Command Acknowledge</i> - Confirms action when in a command menu.</p>
<p>DOWN</p> 	<p><i>Navigation</i> - Moves downwards through the list of parameters.</p> <p><i>Parameter</i> - Decrements the value of the displayed parameter.</p>
<p>ESCAPE</p> 	<p><i>Navigation</i> - Displays the previous level's Menu.</p> <p><i>Parameter</i> - Returns to the parameter list.</p> <p><i>Trip Acknowledge</i> - Acknowledges displayed Trip or Error message.</p>
<p>MENU</p> 	<p><i>Navigation</i> - Displays the next Menu level, or the first parameter of the current Menu.</p> <p><i>Parameter</i> - Holding M down when a parameter is displayed shows that parameter's Tag No. Repeated pressing at a writable parameter moves a cursor across the value to allow rapid increment/decrement of the parameter value.</p>
<p>PROG</p> 	<p><i>Navigation</i> - When in Local mode, displays the previous MMI menu whilst remaining in Local mode enabling changes to be made to parameters not available in Local menu. The key has no function in Remote mode.</p>
<p>LOCAL/ REMOTE</p> 	<p><i>Control</i> - Toggles between Remote and Local Control Modes for both Start/Stop (Seq) and Speed Control (Ref). When toggling, the display automatically goes to the relevant SETPOINT screen, and the SETPOINT (LOCAL) screen will have the ▲ and ▼ keys enabled to alter the setpoint.</p>



Keys for Operating the Converter Locally

<p>FORWARD/ REVERSE</p> 	<p><i>Control</i> - Changes the direction of motor rotation when in Local mode, indicated by the display. Selects between two jog speeds when in Jog mode. This key has no function in Remote mode.</p>
<p>JOG</p> 	<p><i>Control</i> - Runs the motor at a speed determined by the JOG SPEED 1 parameter. When the key is released, the Converter returns to "stopped". Only operates when the Converter is "stopped" and in Local mode. This key has no function in Remote mode.</p>
<p>RUN</p> 	<p><i>Control</i> - Runs the motor at a speed determined by the LOCAL SETPOINT.</p> <p><i>Trip Reset</i> - Resets any trips and then runs the motor as above. Only operates when the Converter is in Local mode.</p>
<p>STOP/RESET</p> 	<p><i>Control</i> - Stops the motor. Only operates when the Converter is in Local mode.</p> <p><i>Trip Reset</i> - Resets any trips and clears displayed message if trip is no longer active.</p>





























Indications











Operator Station LEDs





There are seven LEDs that indicate the status of the Converter. Each LED is considered to operate in three different ways:

-  OFF
-  FLASH
-  ON

The LEDs are labelled HEALTH, LOCAL (as SEQ and REF), FWD, REV, RUN, and STOP. Combinations of these LEDs have the following meanings:

HEALTH	RUN	STOP	Converter State
 	 	 	Re-Configuration
 			Tripped
			Stopped
			Stopping
	 		Running with zero reference
			Running
	 	 	Autotuning

FWD	REV	Forward / Reverse State
		Requested direction and actual direction are forward
		Requested direction and actual direction are reverse
 		Requested direction is forward but actual direction is reverse
	 	Requested direction is reverse but actual direction is forward

LOCAL SEQ	LOCAL REF	Local / Remote Mode
		Start/Stop (Seq) and Speed Control (Ref) are controlled from the terminals
		Start/Stop (Seq) and Speed Control (Ref) are controlled using the Operator Station keys

Operator Station Alarm Messages

An alarm message will be displayed on the MMI when the unit is tripped.

- The Converter has tripped.
The top line indicates a trip has occurred while the bottom line gives the reason for the trip. See example opposite.

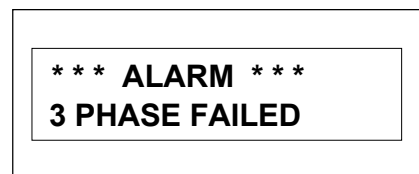

Acknowledge the trip message by pressing the **E** key. Press the **RESET** key to restore the Health LED.

Refer to Chapter 7: “Trips and Fault Finding” for trip messages and reasons.

The Menu System

The menu system is divided into a 'tree' structure with 9 "MENU LEVEL" main menus. Consider these main menus to be at Menu Level 1 (refer to the Menu System Map on the next page). Parameters contained in Menu Level 1 are the most frequently used, as you descend the menu levels the parameters are less frequently used.

The Operator Station has selectable "viewing levels" which can restrict the view of the Remote menu system, refer to "Selecting a Menu Viewing Level", page 5-10.

Below is a simple description of the main menus:

- **DIAGNOSTICS:** a view of important diagnostic parameters contained in the FUNCTION BLOCKS menu.
- **SETUP PARAMETERS:** contains all the function block parameters for programming your application, including parameters for tuning the Converter.
- **PASSWORD:** contains all the Password parameters required for security.
- **ALARM STATUS:** a view of the alarm diagnostic parameters contained in the FUNCTION BLOCKS menu.
- **MENUS:** allows full or reduced menu displays on the Operator Station.
- **PARAMETER SAVE:** Save the application/parameters.
- **SERIAL LINKS:** contains all the parameters for external communications set-up and operation.
- **SYSTEM:** contains all the parameters for I/O configuration.
- **CONFIGURE DRIVE:** a view of the important parameters used when setting-up of the drive.

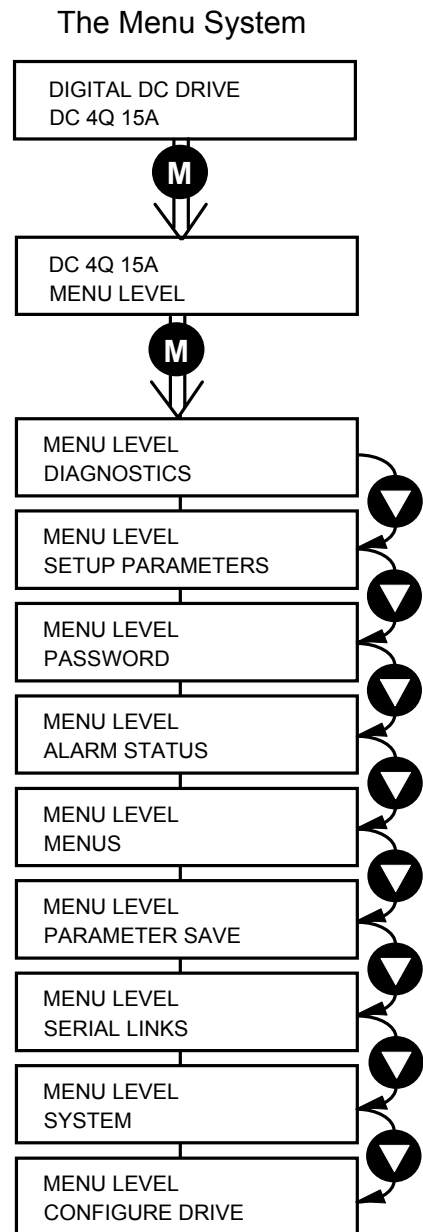

Figure 5-2 The Menu System showing Main Menus and Key Presses

The Local Menu

There is also a separate Local menu which provides Local Setpoint information. This menu can be accessed from anywhere in the Menu System by pressing the **L/R** key. Holding the **M** key down in the Local menu will display additional Feedback information.

A toggle to the Local menu displays whichever is in force, Forward or Reverse, previously selected by the **FWD/REV** key.

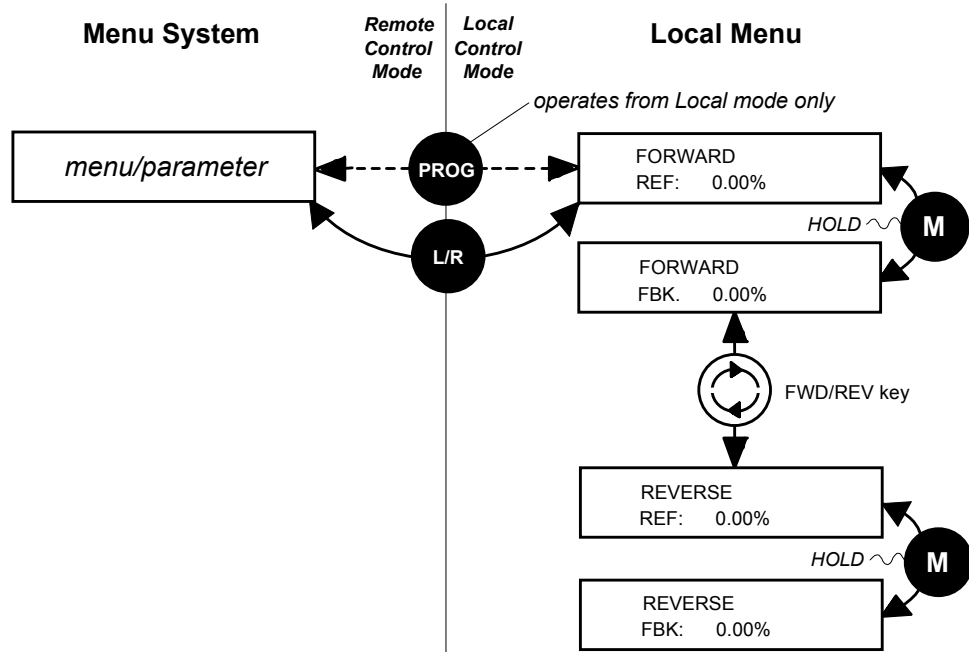

Figure 5-3 Viewing the Local Menu

The L/R Key

The **L/R** key (Local/Remote) only operates when the motor is stopped.

It toggles the drive between Local or Remote control and an appropriate menu on the Operator Station is displayed; either a Local menu when in Local control, or a main programming menu from the Menu System when in Remote control.

When in Local control, the Local LEDs, SEQ and REF, are illuminated and the RUN, STOP, JOG, FORWARD/REVERSE, UP and DOWN local control keys can be used to control the motor speed and direction.

Pressing the **L/R** key when in Local control mode selects Remote control mode and returns you to your previous menu in the Menu System.

The PROG Key

The **PROG** key only operates when in Local control mode.

It toggles the display between the Local menu and the main Menu System but the drive remains in Local control.

Thus, the **PROG** key allows you to make changes to parameters normally available in Remote control mode whilst remaining in Local mode operation.

HINT: When operating the drive locally, it is quite useful to have a relevant parameter selected in the main Menu System for easy access.

5-6 The Operator Station

Navigating the Menu System

The Menu System can be thought of as a map which is navigated using the four keys shown opposite.

- Keys *E* and *M* navigate through the menu levels.
- The up (▲) and down (▼) keys scroll through the Menu and Parameter lists.

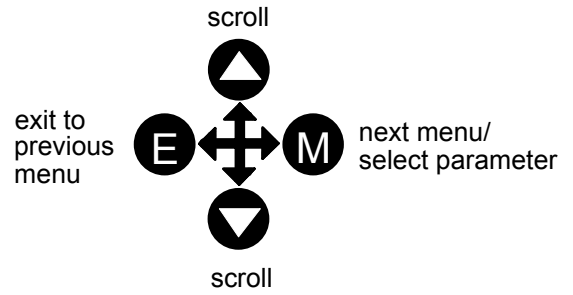

NAVIGATING THE MENU

Menus can contain other menus at a lower level in the tree structure, parameters, or a mixture of both.

The keys are used as above to select a parameter (a parameter has a selection (i.e. ON/OFF) or a value displayed on the bottom line).

HINT: Remember that because the Menu and Parameter lists are looped, the ▲ key can quickly move you to the last Menu or Parameter in the loop. The keys will repeat if you hold them down. This is an easy way to step through and view a menu's contents.

Changing a Parameter Value

With the Parameter you want on view, three of the keys now perform different functions:

- Change a selection (i.e. ON/OFF) using the up (▲) and down (▼) keys.
- Change a value as follows:

The up (▲) and down (▼) keys increment/decrement the value at a rate determined by the right hand character of the value, indicated by the appearance of a cursor.

- ◆ If the cursor is positioned as 100.0, then the value will change by tenths of a unit
- ◆ If the cursor is positioned as 100.0, then the value will change in whole units, etc.

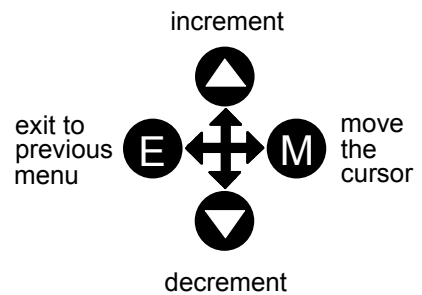

EDITING PARAMETERS

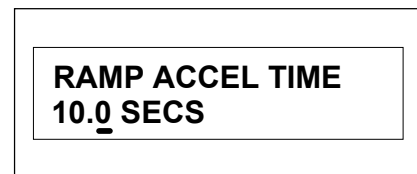

A Parameter showing a cursor under the value

The up (▲) and down (▼) keys will repeat if you hold them down and, at a preset point, the cursor will progressively move one character to the left and increment/decrement the value at an increased rate.

Alternatively, you can move the cursor manually by pressing the M key. Repeated pressing moves the cursor right to left along the value.

The cursor times-out after approximately half a second, so use the M key and up (▲) and down (▼) keys promptly once the cursor is in position.

Note: A cursor appears under all numerical values except for parameters in the Diagnostics and Alarm Status menus whose values provide information only.

The Menu System Map

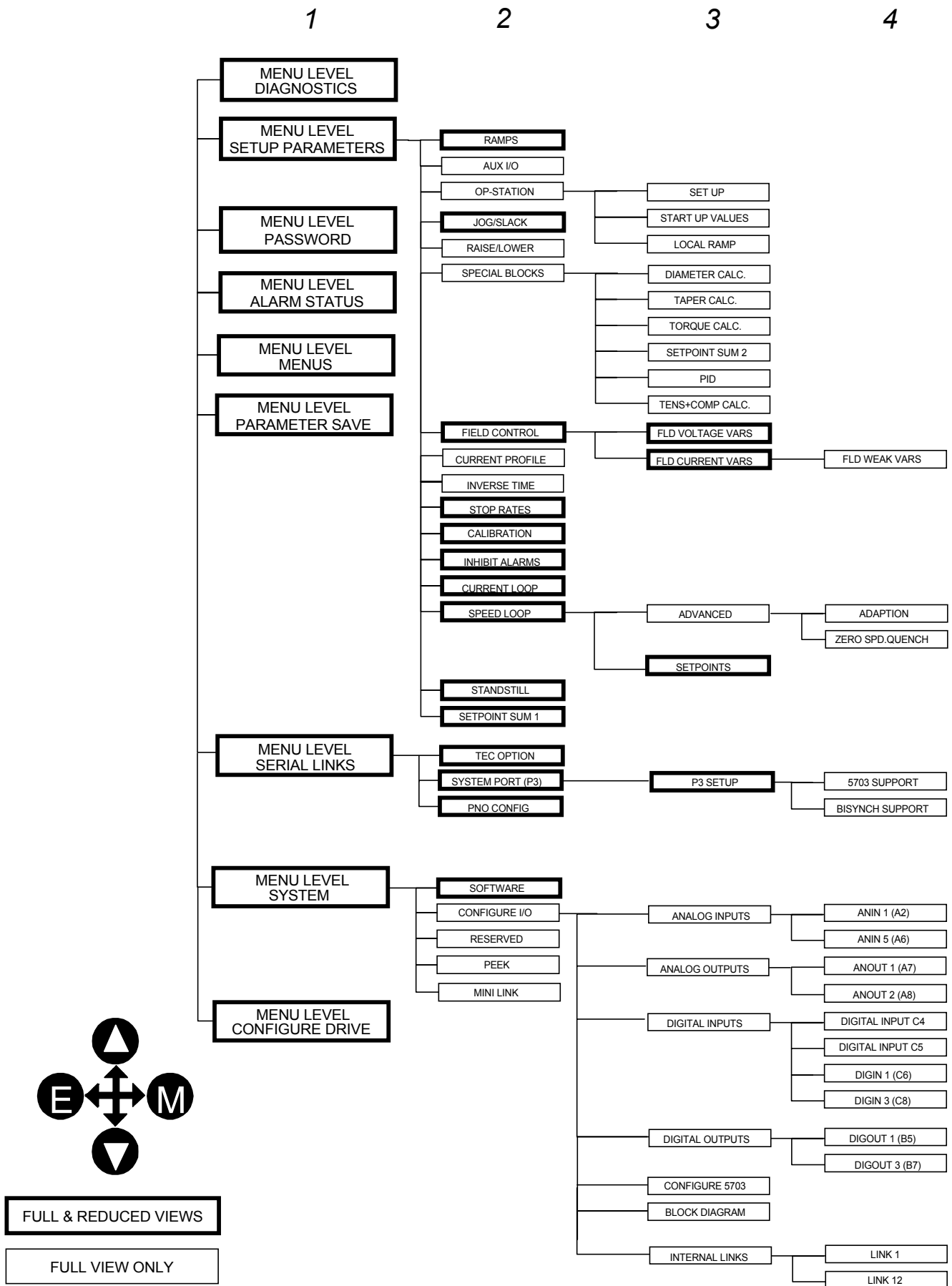

5-8 The Operator Station

Menu Shortcuts and Special Key Combinations

Quick Tag Information

Hold down the **M** key for approximately ½ second in any Menu System parameter to display the Tag number for that parameter.

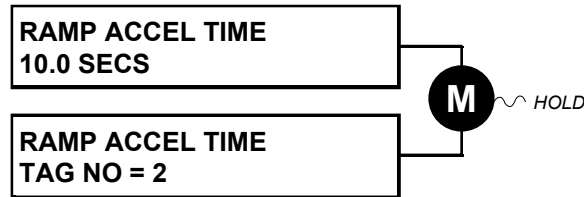

Changing the Stack Size (3-button reset)

Note: This is only necessary if you are installing a new control board on an existing stack.

Power-up the drive holding three keys as described below.

Caution

At this point, the 590+ thinks that it is a 34A model. It is vitally important that it is configured for the correct power rating or irreparable damage may occur to the drive when it attempts to run the motor.

Continue to select the correct Product Code rating. Perform a PARAMETER SAVE now (refer to Saving Your Application, page 5-13).

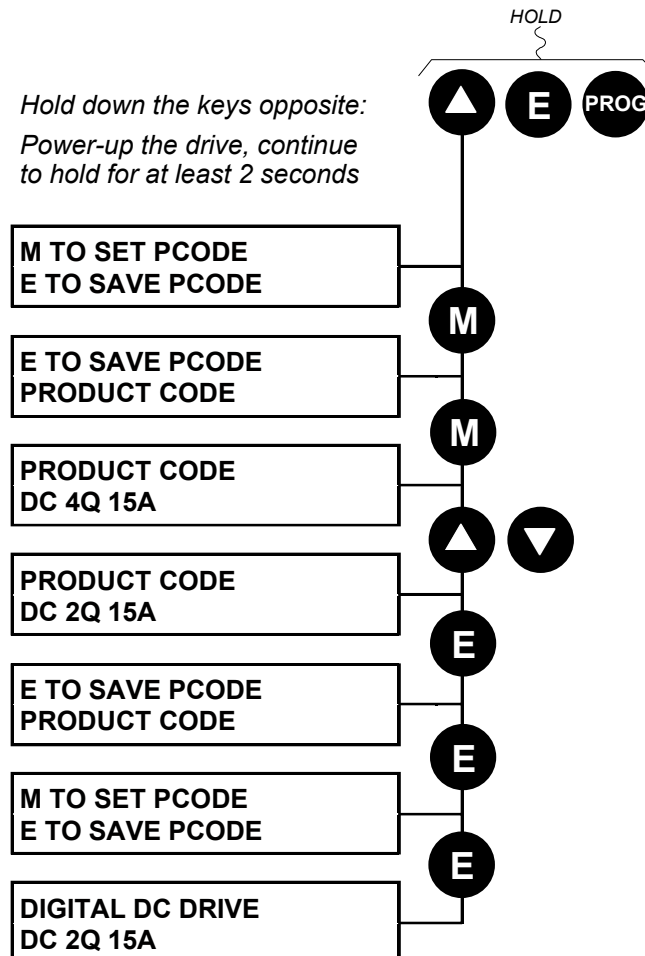

This is the preferred way of selecting a new product code. The available product codes are restricted to the set of codes that match the stack that the control board is fitted to.

If the product code is changed during the 3-button reset, the following parameters are set to their default value for the new product code:

Tag 523	ARMATURE CURRENT
Tag 524	FIELD CURRENT
Tag 201	REGEN MODE

Note: The 3-button reset does not cause the default configuration to be loaded.

Resetting to Factory Defaults (2-button reset)

Power-up the drive holding two keys as described below.

The drive is now safely configured with the default settings detailed in this manual for the existing product code.

The default configuration is not automatically saved to non-volatile memory, so you must perform a PARAMETER SAVE (refer to Saving Your Application, page 5-13).

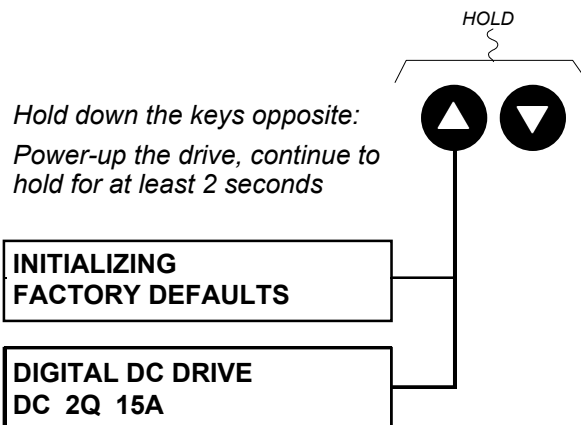

Special Menu Features

Selecting a Menu Viewing Level

For ease of operation there are two `viewing levels` for the MMI: full view or reduced view. The setting for the viewing level decides how much of the menu system will be displayed.

Refer to the Menu System Map, page 5-5 to see how the viewing level changes the displayed menu.

To change the viewing level, go to the MENUS menu. The first parameter in this menu, FULL MENUS selects the viewing level.

- Select DISABLED to use the reduced menu system.
- Select ENABLED to use the full menu system.

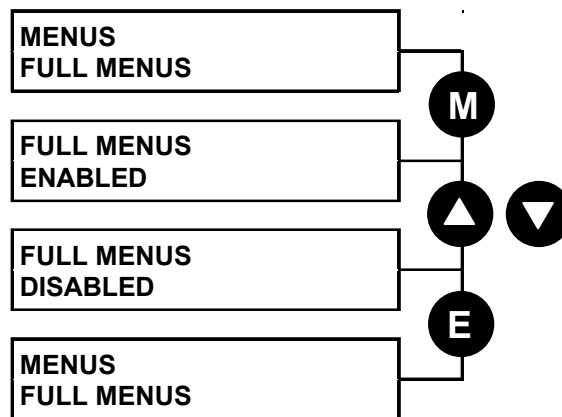
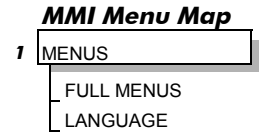

Selecting the Display Language

There is an option to select a different display language.

The choice of display language is selected by the LANGUAGE parameter in the MENUS menu. Remember to perform a PARAMETER SAVE if you need the new language to be saved on power-down.

ENGLISH is the default language and is permanently saved (in Read Only Memory).

A second language is loaded (typically French), however German, Italian and Spanish are available by contacting Eurotherm Drives. When a new language is downloaded it replaces the current second language.

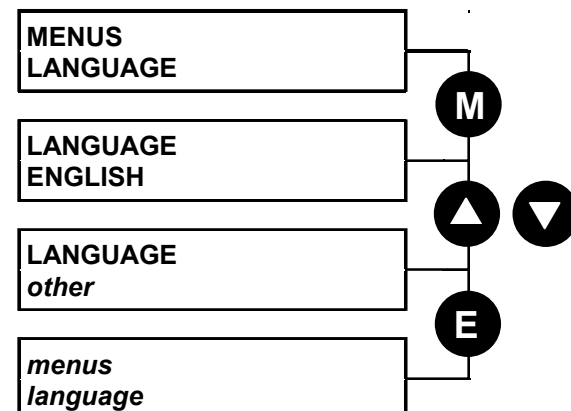
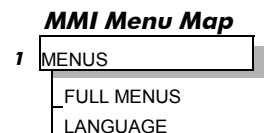

Password Protection

When in force, the password prevents unauthorised parameter modification by making all parameters “read-only”.

If you attempt to modify a password protected parameter, it will cause “PASSWORD ??” to flash on the display.

The password protection is activated/deactivated using the ENTER PASSWORD and CHANGE PASSWORD parameters.

Activated: ENTER PASSWORD and CHANGE PASSWORD values are different

Deactivated: ENTER PASSWORD and CHANGE PASSWORD values are the same

MMI Menu Map

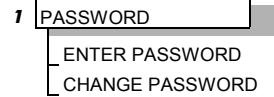

To Activate Password Protection

By default, the password feature is disabled, i.e. both parameters have the same value, 0x0000.

1. Set a new password (anything other than the default value of 0x0000) in the CHANGE PASSWORD parameter, for example 0x0002.
2. The ENTER PASSWORD parameter will now automatically display the new password (e.g. 0x0002). Enter any number other than the password in the ENTER PASSWORD parameter.

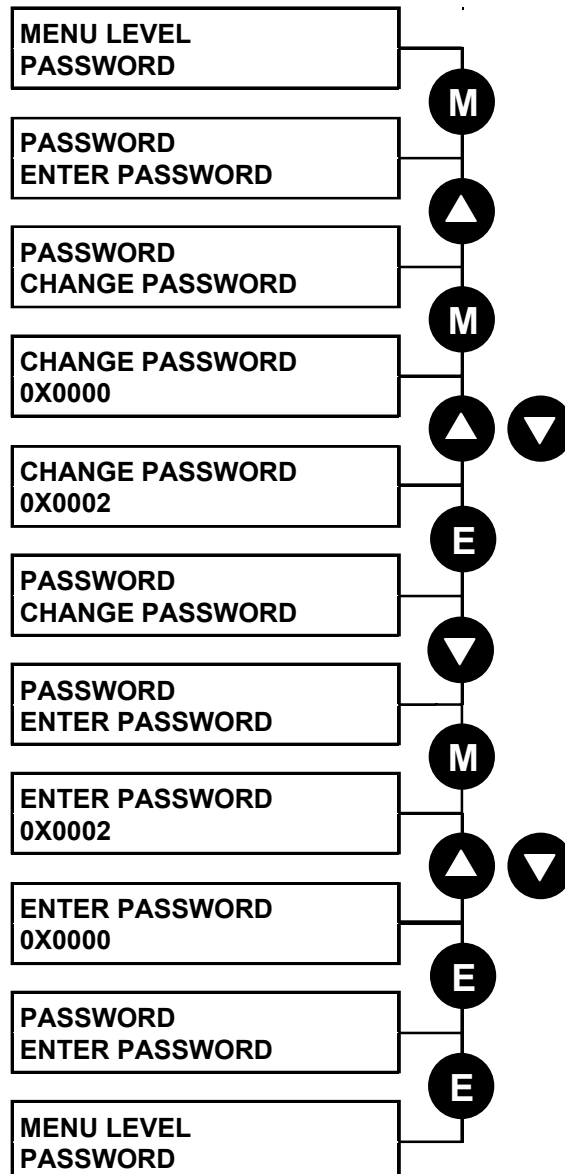

5-12 The Operator Station

To Deactivate Password Protection

With password protection activated, you can no longer edit the CHANGE PASSWORD parameter until you deactivate the password protection (because the value is hidden by “*****”).

1. Enter the current password (e.g. 0x0002) in the ENTER PASSWORD parameter.

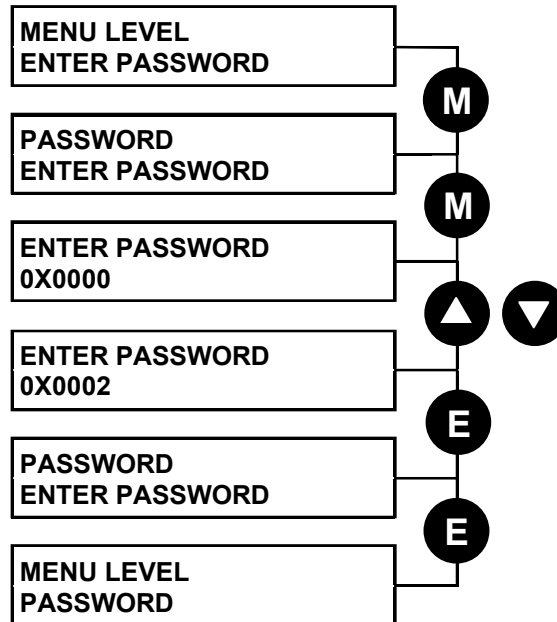

Note: Because the ENTER PASSWORD parameter value is always reset to 0x0000 when powering-up the drive, 0x0000 is the default value for the CHANGE PASSWORD parameter, i.e. by default, the two parameter values are the same and so password protection is disabled.

How to Save, Restore and Copy your Settings

Saving Your Application

Note: Always ensure that CONFIGURE ENABLE = DISABLED before performing a PARAMETER SAVE (when set to ENABLED, the drive cannot run).

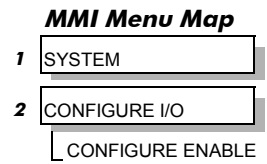
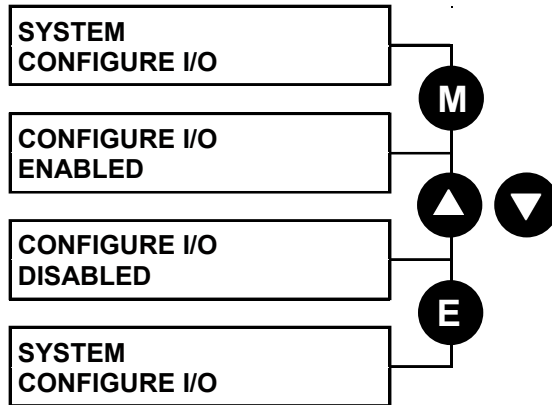

The PARAMETER SAVE menu, available in both the full and reduced view levels, is used to save any changes you make to the MMI settings.

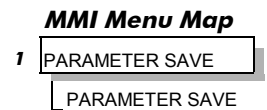
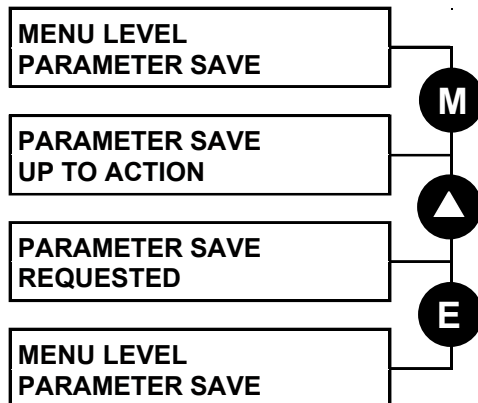

Pressing the ▲ (UP) key, as instructed, saves all parameter values (with one exception, below) in non-volatile memory, i.e. values are stored during power-down.

Note: The local setpoint parameter value is not saved on power-down.

Restoring Saved Settings

If you are unsure about any changes you have made and you have not yet performed a PARAMETER SAVE, simply switch the Converter off, and power-up again. The “last saved” parameter settings will be restored.

Copying an Application

Copying an application requires a host computer connection to the Converter’s System Port (P3). Information can then be downloaded to the computer (and uploaded to the Converter).

Refer to Chapter 14: “Serial Communications” for further information.

5-14 The Operator Station

PROGRAMMING YOUR APPLICATION

Programming with Block Diagrams

You can program the Converter for specific applications using the MMI or suitable programming tool, such as “ConfigEd Lite” which is Eurotherm Drives’ block programming software.

The Converter is supplied with a basic set-up which can be used as a starting point for application-specific programming. This programming could simply involve the inputting of parameter values, or it may require the making or breaking of programmable links, which is a feature of this unit.

Block diagram programming provides a visual method of planning the software to suit your application. The basic block diagram is provided in Chapter 15 and shows the software connections consisting of *function blocks* and *links*:

- Each function block contains the parameters required for setting-up a particular processing feature. Sometimes more than one function block is provided for a feature, i.e. for multiple digital inputs.
- Software links are used to connect the function blocks. Each link transfers the value of an output parameter to an input parameter of another (or the same) function block.

Each individual block is a processing feature, i.e. it takes the input parameter, processes the information, and makes the result available as one or more output parameters.

Modifying a Block Diagram

Configuration and Parameterisation Modes

There are two modes of operation used while modifying a block diagram: *Parameterisation* and *Configuration* modes.

The CONFIGURE ENABLE command is used to toggle between these two modes of operation.

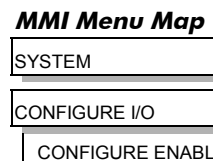

DEFAULT

Parameterisation Mode (CONFIGURE ENABLE = DISABLED)

In parameterisation mode you can change parameter values. The Converter can be running or stopped. Note that some parameters can only be changed when the Converter is stopped. It is not possible to modify the internal links when the Converter is in parameterisation mode.

Configuration Mode (CONFIGURE ENABLE = ENABLED)

In the configuration mode you can modify the links in the function block diagram. You can also change parameter values, as above. The Converter cannot run in this mode. Output values are not updated.

Making and Breaking Links in Configuration Mode

Links can be moved, added or deleted from a block diagram whilst in the Configuration mode. There are 12 general-purpose links available, each has its own identification number (“link” number). You make a link by setting the link’s “source” and “destination” tags to be the two parameter tag numbers to be linked. The outputs of function blocks are not updated whilst in this mode.

Note: Links 11 and 12 can be configured to perform one of a number of basic functions upon the source and/or auxiliary source tag values, to be output at the selected destination tag.

Special Links

In addition to these 12 general-purpose links, there are some links permanently associated with particular input parameters. It is only necessary to enter the source tag number to activate these links. Similarly, there are some links permanently associated with particular output parameters. It is only necessary to enter the destination tag number to activate these links.

All these links may be found in the SYSTEM::CONFIGURE I/O menu.

6-2 Programming Your Application

Programming Rules

The following rules apply when programming:

Parameterisation Mode (**CONFIGURE ENABLE = DISABLED**)

- Function block output parameter values cannot be changed (because they are a result of the function block's processing)
- Function block input parameter values that receive their values from a link cannot be changed (as they will change back to the value they receive from the link when the Converter is running).

Configuration Mode (**CONFIGURE ENABLE = ENABLED**)

- A link's destination tag must be set to an input parameter (only one link per input parameter).
- A link's source tag may be set to any parameter. Both input and output parameters can be used as a source.
- Disable a link/function block by setting the "destination" and "source" tag to zero.

Saving Your Modifications

Ensure that CONFIGURE ENABLE = DISABLED before performing a PARAMETER SAVE.

If parameter values or links have been modified, the new settings must be saved. The Converter will then retain the new settings during power-down. Refer to Chapter 5: "The Operator Station" - Saving Your Application.

Understanding the Function Block Description

The following function blocks show the parameter information necessary for programming the Converter.

Input parameters are shown on the left hand side, and output parameters are shown on the right hand side of the block.

Some parameters are indicated as "Reserved", these parameters are for use by Eurotherm.

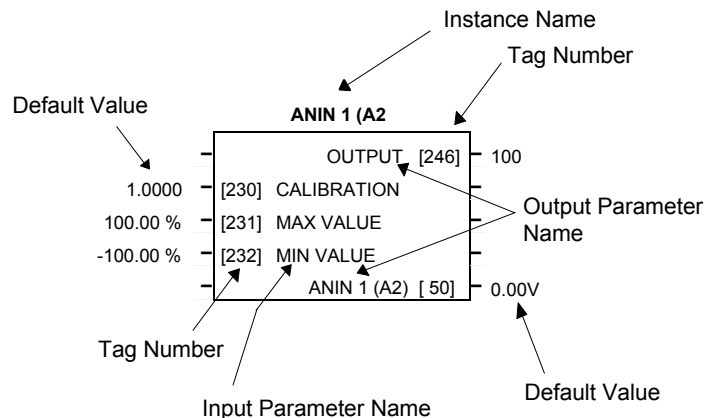
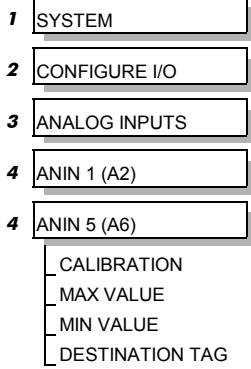

Figure 6-1 Function Block Parameter Information

Instance Name	Names the function block type
Default Value	The default value of the unmodified factory set-up
Input/Output Parameter Name	The name shown on ConfigEd Lite
Tag Number	Unique identification used for linking and communications

Note: Decimal Places - some internally held parameters with two decimal places are only displayed with one decimal place. These parameters are indicated in the Parameter Description tables. The Range parameter highlights these with "(h)".

MMI Menu Map



MMI Menu Maps

The function block descriptions include an easy-find menu showing the menu levels and titles encountered to find the appropriate menu title, and the parameters contained in the menu(s).

The menu maps are shown as if the full view level is selected.

Where there is more than one sub-menu, i.e. ANALOG INPUTS as illustrated, the parameters shown will be for the last sub-menu. In many cases, these parameters will reflect the name and number of the last sub-menu.

Because of this intuitive naming of parameters, which is designed to make using the Operator Station easier, MMI parameter names may vary slightly from Function Block names.

A function block may also be represented by more than one MMI menu, e.g. FIELD CONTROL. In contrast, the DIAGNOSTICS menu on the MMI is greatly reduced in the DIAGNOSTICS function block, the remaining parameters being included in related function blocks.

6-4 Programming Your Application

Function Block Descriptions

Note: Remember to select the correct mode, Parameterisation or Configuration, whilst editing. Refer back to "Modifying a Block Diagram", page 6-1. You must select the full view level to see all of the function blocks, go to MENUS menu at level 1 on the MMI.

Function Block	Page	Function Block	Page
ANALOG INPUTS	6-5 *	OP STATION	6-44
ANALOG OUTPUTS	6-7 *	↳ SET UP	
AUX I/O	6-8 *	↳ START UP VALUES	
BLOCK DIAGRAM (MMI only)	6-13	↳ LOCAL RAMP	
CALIBRATION	6-14 *	PASSWORD (MMI only)	6-46
↳ CONFIGURE DRIVE		PID	6-47 *
CONFIGURE DRIVE (MMI only)	6-17	RAISE/LOWER	6-50 *
CURRENT LOOP	6-18 *	RAMPS	6-52 *
↳ CONFIGURE DRIVE		SETPOINT SUM 1	6-56 *
CURRENT PROFILE	6-21	SETPOINT SUM 2	6-57
DIAGNOSTICS	6-22 *	SPEED LOOP	6-59 *
DIAMETER CALC	6-27	↳ SETPOINTS	
DIGITAL INPUTS	6-29 *	↳ CONFIGURE DRIVE	
↳ DIGITAL INPUT C4 & C5		ADVANCED (Speed Loop)	6-59
DIGITAL OUTPUTS	6-31 *	↳ ADAPTION	
FIELD CONTROL	6-32 *	↳ ZERO SPD QUENCH	
↳ FLD VOLTAGE VARS		STANDSTILL	6-64 *
↳ FLD CURRENT VARS		STOP RATES	6-65 *
↳ FLD WEAK VARS		SYSTEM PORT P3	6-67
↳ CONFIGURE DRIVE		↳ P3 SETUP	
ALARMS	6-35 *	↳ BISYNCH SUPPORT	
↳ INHIBIT ALARMS		5703 SUPPORT	6-68
↳ ALARM STATUS		TAPER CALC	6-69
↳ CALIBRATION		TEC OPTION	6-70
JOG/SLACK	6-38 *	TENS+COMP CALC	6-71
LINK 11 & LINK 12	6-40	↳ BLOCK DIAGRAM	
MENUS	6-42	TORQUE CALC	6-73
miniLINK	6-43	↳ BLOCK DIAGRAM	
		USER FILTER	6-74

* These function blocks contain parameters from the DIAGNOSTICS menu on the MMI.

ANALOG INPUTS

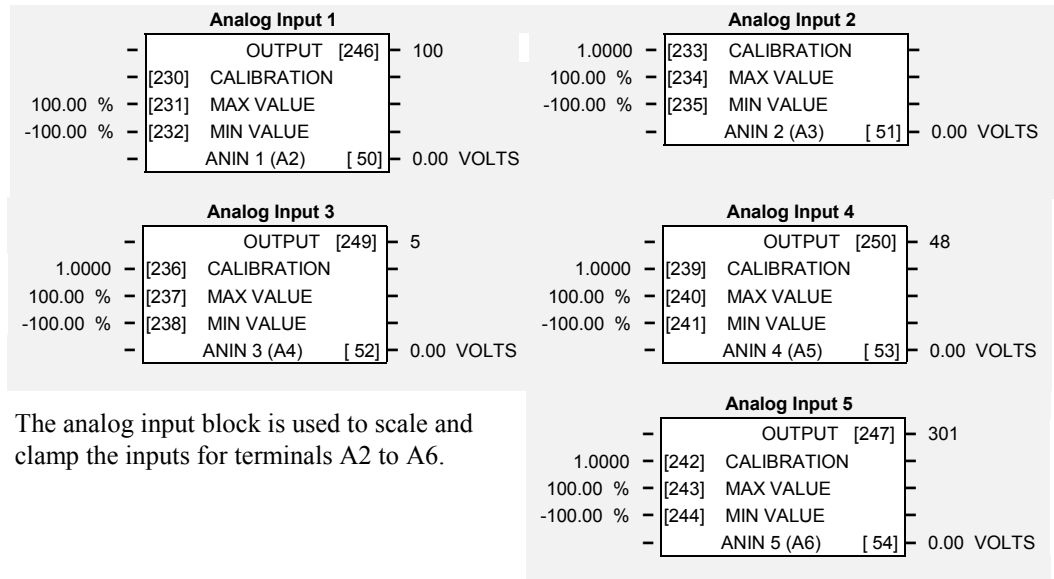
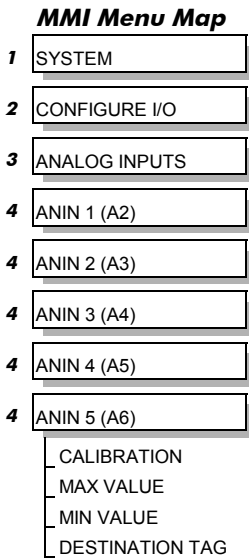

The analog input block is used to scale and clamp the inputs for terminals A2 to A6.

Note: ANIN 2 (A3) is not reconfigurable and is connected directly to the SETUP PARAMETERS:: SPEED LOOP:: SETPOINTS:: RATIO 2 (A3) input, and the SETUP PARAMETER:: CURRENT LOOP:: I DMD. ISOLATE switch. Refer to Chapter 15: "The Default Application" - Main Block Diagram for more information.

Tag 493 allows access to the calibrated value of ANIN 2 (via an internal link for example). To avoid interference with other drive functions the parameter RATIO 2 (A3) must be set to zero, and the I DMD. ISOLATE parameter must be set to DISABLED, i.e. selecting the Speed Loop as shown in the Main Block Diagram.

ANIN 2 (A3) is a direct input into the speed loop/current loop and is scanned synchronously with the current loop (typically every 3.33ms) rather than every micro cycle time (typically 7ms). Therefore it should be used for any signal whose response is critical e.g. a trim input from a digital speed and position locking system.

Parameter Descriptions

OUTPUT

Range: 0 to 549

(DESTINATION TAG)

The destination Tag No. of the scaled analog input value. Refer to "Special Links", page 6-1.

CALIBRATION

Range: -3.0000 to 3.0000

The analog input scaling ratio.

MAX VALUE

Range: -300.00 to 300.00 %

The maximum value of the scaled analog input.

MIN VALUE

Range: -300.00 to 300.00 %

The minimum value of the scaled analog input

ANIN 1 (A2) to ANIN 5 (A6)

Range: xxx.xx VOLTS

Refer to the DIAGNOSTICS function block description, page 6-22.

6-6 Programming Your Application

Functional Description

Configurable Analog Inputs

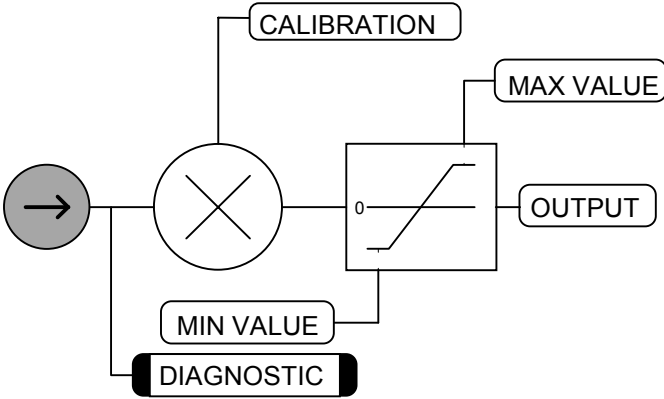

ANALOG OUTPUTS

MMI Menu Map

- 1 SYSTEM
- 2 CONFIGURE I/O
- 3 ANALOG OUTPUTS
- 4 ANOUT 1 (A7)
 - % TO GET 10V
 - MODULUS
 - OFFSET
 - SOURCE TAG

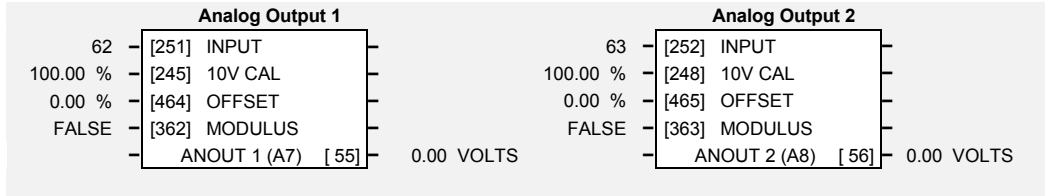

This function block converts the demand percentage into a form suitable for driving the analog output electronics of the Converter.

Parameter Descriptions

INPUT

Range: 0 to 549

(SOURCE TAG)

The source Tag No. of the output value.

10V CAL

Range: -300.00 to 300.00 %

(% TO GET 10V)

Scaler value which produces 10V output.

OFFSET

Range: -100.00 to 100.00 %

Offset value added to the normal output value after the scaler and before the modulus.

MODULUS

Range: See below

Unsigned analog output enable.

0 : FALSE

1 : TRUE

ANOUT 1 (A7) to ANOUT 2 (A8)

Range: xxx.xx VOLTS (h)

Refer to the *DIAGNOSTICS* function block description, page 6-22.

Functional Description

Configurable Analog Outputs

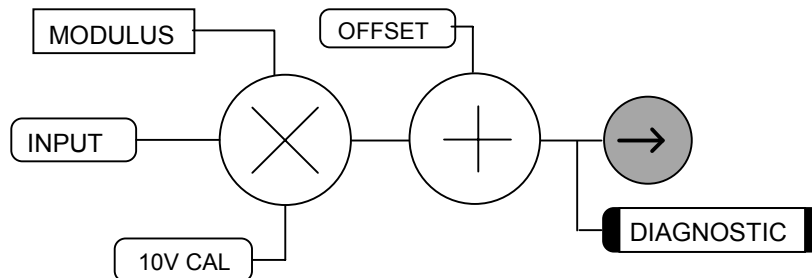

6-8 Programming Your Application

MMI Menu Map

1	SETUP PARAMETERS
2	AUX I/O
	AUX START
	AUX JOG
	AUX ENABLE
	AUX DIGOUT 1
	AUX DIGOUT 2
	AUX DIGOUT 3
	ANOUT 1
	ANOUT 2
	JOG/SLACK
	ENABLE
	REM.SEQ.ENABLE
	REM.SEQUENCE
	SEQ STATUS

AUX I/O

The auxiliary I/O parameters are primarily intended to extend the functionality of the serial links by allowing them access to the drive analog and digital terminals.

START, JOG and ENABLE from digital input terminals C3, C4 and C5 respectively connect directly to the AUX I/O block.

Output signals are then sent to the drive start and drive enable logic and the JOG/SLACK function block.

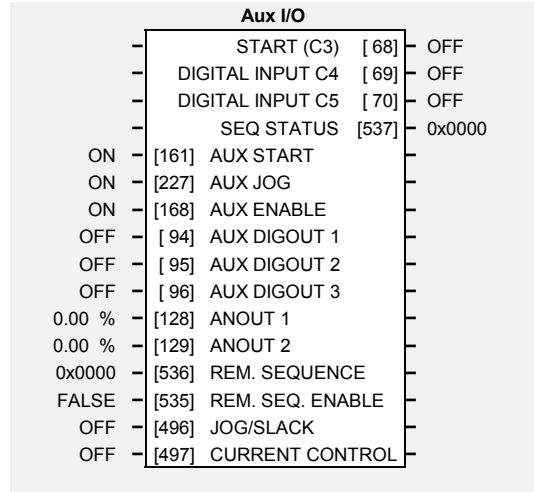

Parameter Descriptions

START (C3)

Range: See below

Refer to the *DIAGNOSTICS* function block description, page 6-22.

- 0 : OFF
- 1 : ON

DIGITAL INPUT C4

Range: See below

Refer to the *DIAGNOSTICS* function block description, page 6-22.

- 0 : OFF
- 1 : ON

DIGITAL INPUT C5

Range: See below

Refer to the *DIAGNOSTICS* function block description, page 6-22.

- 0 : OFF
- 1 : ON

SEQ STATUS

Range: 0x0000 to 0xFFFF

A status word that groups important system flags together for use by remote device over a network. (Refer to “Remote Sequencing” below).

AUX START

Range: See below

Software Start/Run command.

- 0 : OFF
- 1 : ON

AUX JOG

Range: See below

Software Jog command.

- 0 : OFF
- 1 : ON

AUX ENABLE

Range: See below

Software Enable command.

- 0 : OFF
- 1 : ON

- AUX DIGOUT 1** *Range: See below*
 Software digital output 1.
 0 : OFF
 1 : ON
- AUX DIGOUT 2** *Range: See below*
 Software digital output 2.
 0 : OFF
 1 : ON
- AUX DIGOUT 3** *Range: See below*
 Software digital output 3.
 0 : OFF
 1 : ON
- ANOUT 1** *Range: -100.00 to 100.00 %*
 Software analog output 1.
- ANOUT 2** *Range: -100.00 to 100.00 %*
 Software analog output 2.
- REM. SEQUENCE** *Range: 0x0000 to 0xFFFF*
 (REM.SEQUENCE)
 A control word that allows the device to be operated remotely. REM. SEQ. ENABLE must be True to enable this function. (Refer to "Remote Sequencing" below).
- REM. SEQ. ENABLE** *Range: See below*
 (REM.SEQ.ENABLE)
 (Refer to "Remote Sequencing" below).
 0 : FALSE - disables REM. SEQUENCE
 1 : TRUE - enables REM. SEQUENCE
- JOG/SLACK** *Range: See below*
 Jog input which is connected to DIGITAL INPUT C4 by default.
 0 : OFF
 1 : ON
- CURRENT CONTROL** *Range: See below*
 (ENABLE)
 Enable input which is connected to DIGITAL INPUT C5 by default.
 0 : OFF
 1 : ON

Functional Description

The external device sends its signal directly to the required tag (PNO). In the case of auxiliary digital inputs AUX START, AUX JOG and AUX ENABLE, the overall input will be the result of the "AND" gating of the normal terminal signal with the auxiliary signal from an external computer or PLC.

The remaining auxiliary outputs allow external computers to directly control the output terminals. These connections are set in SYSTEM::CONFIGURE I/O.

ANOUT 1 & 2 can also be used as general "staging posts" for connecting inputs to outputs.

Example: Connect Analog Input 1 (A2) directly to Analog Output 1 (A7)

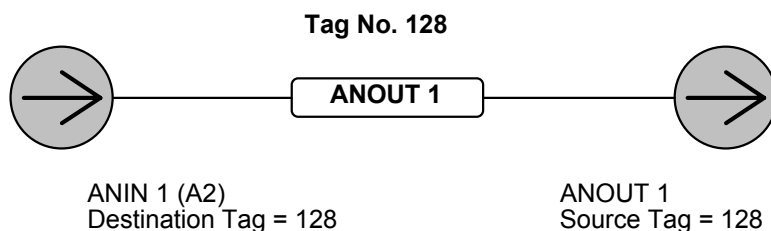

6-10 Programming Your Application

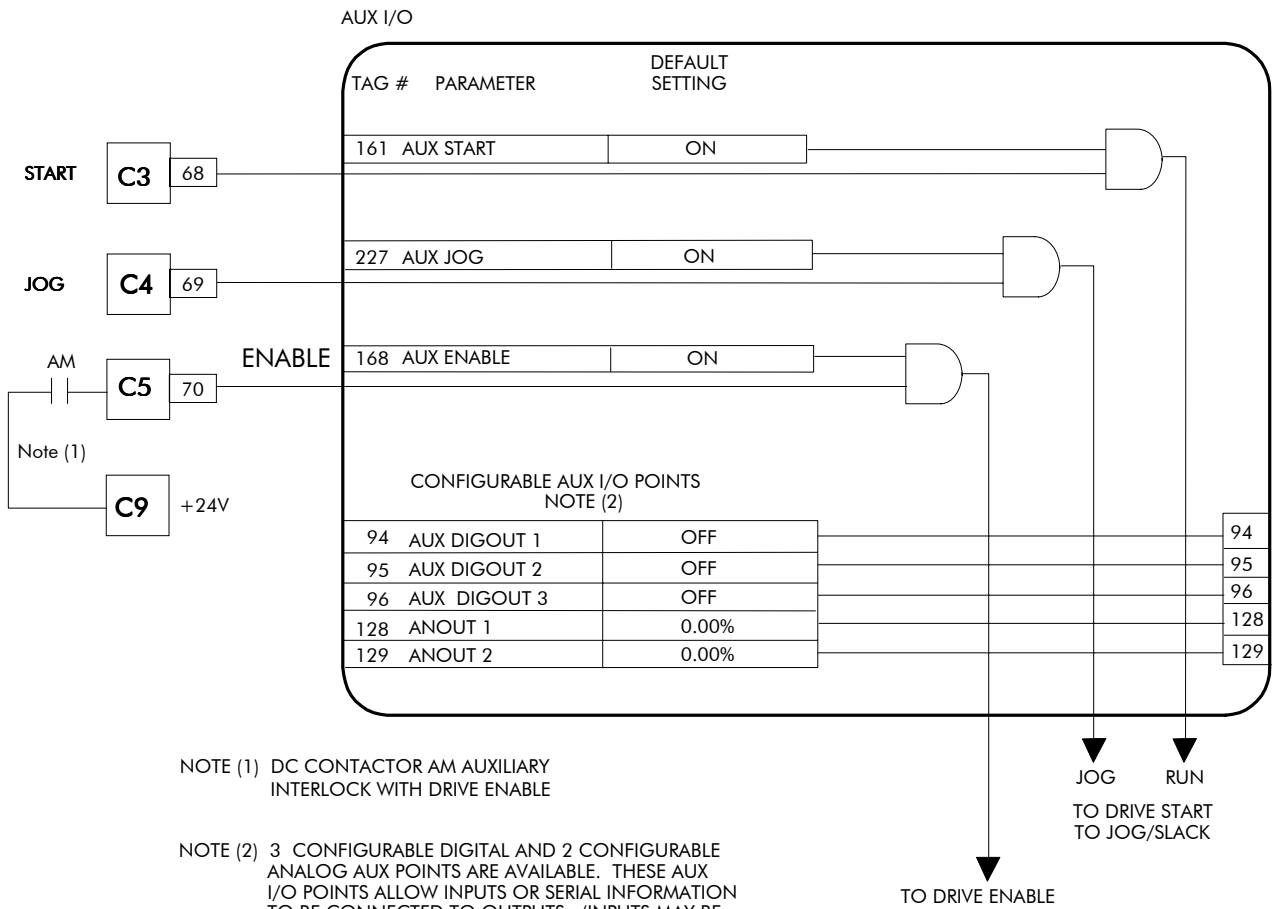

Remote Sequencing

REM. SEQUENCE

Tag 536, Mnemonic "ow", Default = 0x0000

Reserved bits are undefined when read and should be set Zero when written.

Bit Number	Mask	Name	Comment
0 (lsb)	0x0001	Remote Enable	
1	0x0002	Remote Start	
2	0x0004	Remote Jog	
3	0x0008	Remote Jog Mode	Selects Jog Speed
4	0x0010	Reserved	
5	0x0020	Reserved	
6	0x0040	Reserved	
7	0x0080	Reserved	
8	0x0100	Remote Alarm Ack	Alarm Acknowledge
9	0x0200	Remote/Remote Trip	Remote Trip (High for OK)
10	0x0400	Reserved	
11	0x0800	Reserved	
12	0x1000	Reserved	
13	0x2000	Reserved	
14	0x4000	Reserved	
15	0x8000	Reserved	

SEQ STATUS

Tag 537, Mnemonic "ox" (Read Only) , Default = FALSE

Reserved bits are undefined when read.

Bit Number	Mask	Name	Comment
0 (lsb)	0x0001	Coast Stop	Coast Stop demanded
1	0x0002	Program Stop	Program (Fast) Stop demanded
2	0x0004	Disable	/Enable demanded
3	0x0008	Run	Drive Start demanded
4	0x0010	Jog	Drive Jog demanded
5	0x0020	Reserved	Undefined
6	0x0040	Alarm	Unacknowledged alarm (Health Store != 0)
7	0x0080	Reserved	Undefined
8	0x0100	Running	Contactor in and drive ready to be enabled
9	0x0200	Enabled	Drive is enabled.
10	0x0400	Zero Speed	Zero speed Output TAG 17
11	0x0800	Healthy Output	Healthy Output TAG 12
12	0x1000	Ready	Ready Output TAG 559
13	0x2000	Reserved	Undefined
14	0x4000	Reserved	Undefined
15	0x8000	Reserved	Undefined

Useful Bit Patterns

Sequence Status	Comment
0001 1011 0000 1011	Running
0000 0100 0100 1011	Tripped, Run High
0000 0100 0100 0111	Tripped, Run Low, Enable Low
0000 1100 0100 0111	Trip Acknowledged, Healthy o/p TRUE Alarm stays high until drive is restarted.

Useful commands using EI-ASCII - REM. SEQUENCE

Tag 536, Mnemonic "ow", Default = 0x0C07

	/Remote Trip	Alarm Ack	Jog Mode	Jog	Start	Enable	Command
Start Drive	1	0	X	0	1	1	ow>0203
Stop Drive	1	0	X	0	0	1	ow>0201
Disable Drive	1	0	X	X	X	0	ow>0200
Jog Setpoint 1	1	0	0	1	0	1	ow>0205
Jog Setpoint 2	1	0	1	1	0	1	ow>020C
Remote Trip	0	0	X	X	X	X	ow>0000
Reset Alarm a)	1	1	0	0	0	0	ow>0300
Reset Alarm b)							Healthy Output Bit 11
Reset Alarm c)	1	0	50	0	0	0	ow>0200

6-12 Programming Your Application

Drive Enable

To Enable the drive in remote mode the following parameters must be TRUE:

REM.SEQ.ENABLE[535] and REM SEQUENCE [536] BIT 1.

Drive Start

To Start the drive in remote mode the following parameters must be TRUE:

REM.SEQ.ENABLE[535] and REM SEQUENCE [536] BIT 0.

Drive Jog

To Jog the drive in remote mode the following parameters must be TRUE:

REM.SEQ.ENABLE[535] and REM SEQUENCE [536] BIT 3.

Jog Mode

To select the jog setpoint in remote mode the following parameters must be TRUE:

REM.SEQ.ENABLE[535] and REM SEQUENCE [536] BIT 4.

ACK Alarm

To Acknowledge an alarm the following parameter must be TRUE:

REM SEQUENCE [536] BIT 8.

NOTE: if remote sequencing is not enabled then REM SEQUENCE [536] BIT 8 is forced TRUE.

Remote Trip Alarm

The Remote trip alarm is designed to signal a network fault to the drive. When using the Profibus interface, all outputs are set to zero on link fail. If one of the outputs is REM SEQUENCE [536] the drive will trip after a delay specified by REM TRIP DELAY (541). The Drive will then need a low -> high transition on ACK Alarm and Start before the drive may run again.

REM TRIP INHIBIT [540]	REM TRIP DELAY [541]	REMOTE TRIP [542]
Disable remote trip.	Delay before trip becomes active after bit being cleared.	Status of the Remote trip alarm, OK, Warning (Remote Seq Bit 9 FALSE and delay not expired), Active (Trip active, timer expired and remote not inhibited).

BLOCK DIAGRAM (MMI only)

The parameters in Block Diagram connect the outputs of RAISE/LOWER, RAMPS, SETPOINT SUM 1, and the Special Blocks (MMI menu) functions to destinations as required. These functions are only executed when the destinations are connected to a non-zero tag. If a function is not required, set its destination tag to zero. This causes the processor to ignore the function and reduces processor loading.

MMI Menu Map

1	SYSTEM
2	CONFIGURE I/O
3	BLOCK DIAGRAM
	RAISE/LOWER DEST
	RAMP O/P DEST
	SPT SUM 1 DEST
	PID O/P DEST
	DIAMETER
	TAPER
	SETPOINT SUM 2
	POS. I CLAMP
	NEG. I CLAMP
	TENS+COMP CALC.

Parameter Descriptions

<p>RAISE/LOWER DEST Refer to RAISE/LOWER, page 6-50.</p>	<p><i>Range: 0 to 549</i></p>
<p>RAMP O/P DEST Refer to RAMPS, page 6-52.</p>	<p><i>Range: 0 to 549</i></p>
<p>SPT SUM 1 DEST Refer to SETPOINT SUM 1, page 6-56.</p>	<p><i>Range: 0 to 549</i></p>
<p>PID O/P DEST Refer to PID, page 6-47.</p>	<p><i>Range: 0 to 549</i></p>
<p>DIAMETER Refer to DIAMETER CALC., page 6-27.</p>	<p><i>Range: 0 to 549</i></p>
<p>TAPER Refer to Error! Not a valid result for table., page 6-72.</p>	<p><i>Range: 0 to 549</i></p>
<p>SETPOINT SUM 2 Refer to SETPOINT SUM 2, page 6-57.</p>	<p><i>Range: 0 to 549</i></p>
<p>POS. I CLAMP Refer to CURRENT LOOP, page 6-18.</p>	<p><i>Range: 0 to 549</i></p>
<p>NEG. I CLAMP Refer to CURRENT LOOP, page 6-18.</p>	<p><i>Range: 0 to 549</i></p>
<p>TENS+COMP CALC. Refer to TENS+COMP CALC., page 6-71.</p>	<p><i>Range: 0 to 549</i></p>

CALIBRATION

This function block contains motor-specific parameters.

CONFIGURE ENABLE: The operation of the Block Diagram is suspended and all Operator Station LEDs will flash whilst **CONFIGURE ENABLE = TRUE**.

MMI Menu Map

1	SETUP PARAMETERS
2	CALIBRATION
	CONFIGURE ENABLE
	NOM MOTOR VOLTS
	ARMATURE CURRENT
	FIELD CURRENT
	ARMATURE V CAL.
	IR COMPENSATION
	ENCODER RPM
	ENCODER LINES
	ANALOG TACH CAL
	ZERO SPD. OFFSET
	ARMATURE I (A9)
	SPDFBK ALM LEVEL
	STALL THRESHOLD
	STALL TRIP DELAY
	REM TRIP DELAY
	OVER SPEED LEVEL
	FIELD I CAL.

MMI Menu Map

1	CONFIGURE DRIVE
	CONFIGURE ENABLE
	NOM MOTOR VOLTS
	ARMATURE CURRENT
	FIELD CURRENT
	ENCODER LINES
	ENCODER RPM

Calibration		
	TERMINAL VOLTS [57]	0.00%
	TACH INPUT (B2) [58]	0.0%
	ENCODER [59]	0 RPM
	BACK EMF [60]	0.00%
	FIELD FBK. [181]	0.0%
1.0000	[20] ARMATURE V CAL.	
0.00 %	[21] IR COMPENSATION	
1000 RPM	[22] ENCODER RPM	
1000	[24] ENCODER LINES	
1.0000	[23] ANALOG TACH CAL	
0.00 %	[10] ZERO SPD. OFFSET	
BIPOLAR	[25] ARMATURE I (A9)	
50.00 %	[180] SPDFBK ALM LEVEL	
95.00 %	[263] STALL THRESHOLD	
10.0 SECS	[224] STALL TRIP DELAY	
125.00 %	[188] OVERSPEED LEVEL	
1.0000	[182] FIELD I CAL	
0x0000	[267] POSITION COUNT	
1	[275] POSITION DIVIDER	
100 VOLTS	[521] NOM MOTOR VOLTS	
2.0 AMPS	[523] ARMATURE CURRENT	
0.2 AMPS	[524] FIELD CURRENT	

Parameter Descriptions

TERMINAL VOLTS

Range: xxx.xx % (h)

Refer to the *DIAGNOSTICS* function block description, page 6-22.

TACH INPUT (B2)

Range: xxx.xx % (h)

(RAW TACH INPUT)

Refer to the *DIAGNOSTICS* function block description, page 6-22.

ENCODER

Range: xxxxx RPM

(RAW ENCODER RPM)

Refer to the *DIAGNOSTICS* function block description, page 6-22.

BACK EMF

Range: xxx.xx % (h)

Refer to the *DIAGNOSTICS* function block description, page 6-22.

FIELD FBK.

Range: xxx.xx %

(RAW FIELD FBK)

Refer to the *DIAGNOSTICS* function block description, page 6-22.

ARMATURE V CAL.

Range: 0.9800 to 1.1000

Trim adjustment of the motor armature volts to give exactly 100% at the required actual voltage value (e.g. 460V etc.).

Note: - Primary voltage calibration is achieved by adjusting VA calibration values using SW7.

IR COMPENSATION

Range: 0.00 to 100.00 %

Compensation for motor IR drop to improve regulation when using armature voltage feedback as the speed feedback. This is also used in field weakening applications to improve dynamic response and speed holding stability, refer to “Initial Start-up Routine” in Chapter 4, Item 16.

ENCODER RPM

Range: 0 to 6000 RPM

Motor top speed setting when using encoder feedback.

ENCODER LINES

Range: 10 to 5000

The 5901 Microtach has 1000 lines per revolution as standard. Proprietary encoders of other specifications can be normalised by setting this parameter as appropriate.

ANALOG TACH CAL

Range: 0.9800 to 1.1000

Trim adjustment of the motor speed to give exactly 100% at the required actual speed value (e.g. 1500 RPM etc). *Note: Primary tacho calibration is achieved by adjusting SW1 - 3 on the tacho calibration board.*

ZERO SPD. OFFSET

Range: -5.00 to 5.00 %

If the speed feedback is not zero when the drive is stationary (possibly due to hardware offsets etc.) the setting of this parameter to the value of the offset will result in a zero reading from the speed feedback.

ARMATURE I (A9)

Range: See below

Selects operation of the current meter output (terminal A9), either bipolar or unipolar.

0 : UNIPOLAR

1 : BIPOLAR

SPDFBK ALM LEVEL

Range: 0.00 to 100.00 % (h)

The speed feedback alarm compares speed feedback to armature voltage. The alarm level is the threshold which the difference between the two signals should exceed for the alarm to activate.

STALL THRESHOLD

Range: 0.00 to 200.00 %

Stall comparator current feedback threshold level.

STALL TRIP DELAY

Range: 0.1 to 600.0 SECS

Stall comparator time-out delay before stall output becomes true.

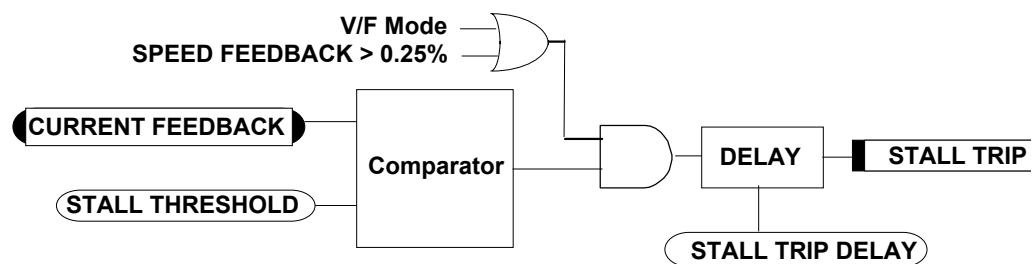

OVERSPEED LEVEL

Range: 0.00 to 200.00 %

(OVER SPEED LEVEL)

Speed feedback level for overspeed alarm

FIELD I CAL

Range: 0.9800 to 1.1000

(FIELD I CAL.)

Trim adjustment of the motor field current to give exactly 100% at the required actual current value (e.g. 1.5A etc.). *Note: Primary field calibration is achieved by adjusting IF calibration using SW1 - 3.*

POSITION COUNT

Range: 0x0000 to 0xFFFF

Reserved parameter for use by Eurotherm Drives.

POSITION DIVIDER

Range: 1 to 30000

Reserved parameter for use by Eurotherm Drives.

NOM MOTOR VOLTS

Range: 100 to 875 VOLTS

Sets the 100% value for Armature Volts VA. Set this value to match the motor in use.

ARMATURE CURRENT

Range: 2.0 to 15.0 AMPS

Sets the 100% value for Armature Current IA. Set this value to match the motor in use.

FIELD CURRENT

Range: 0.2 to 5.0 AMPS

Sets the 100% value for Field Current IF. Set this value to match the motor in use.

6-16 Programming Your Application

Functional Description

CALIBRATION

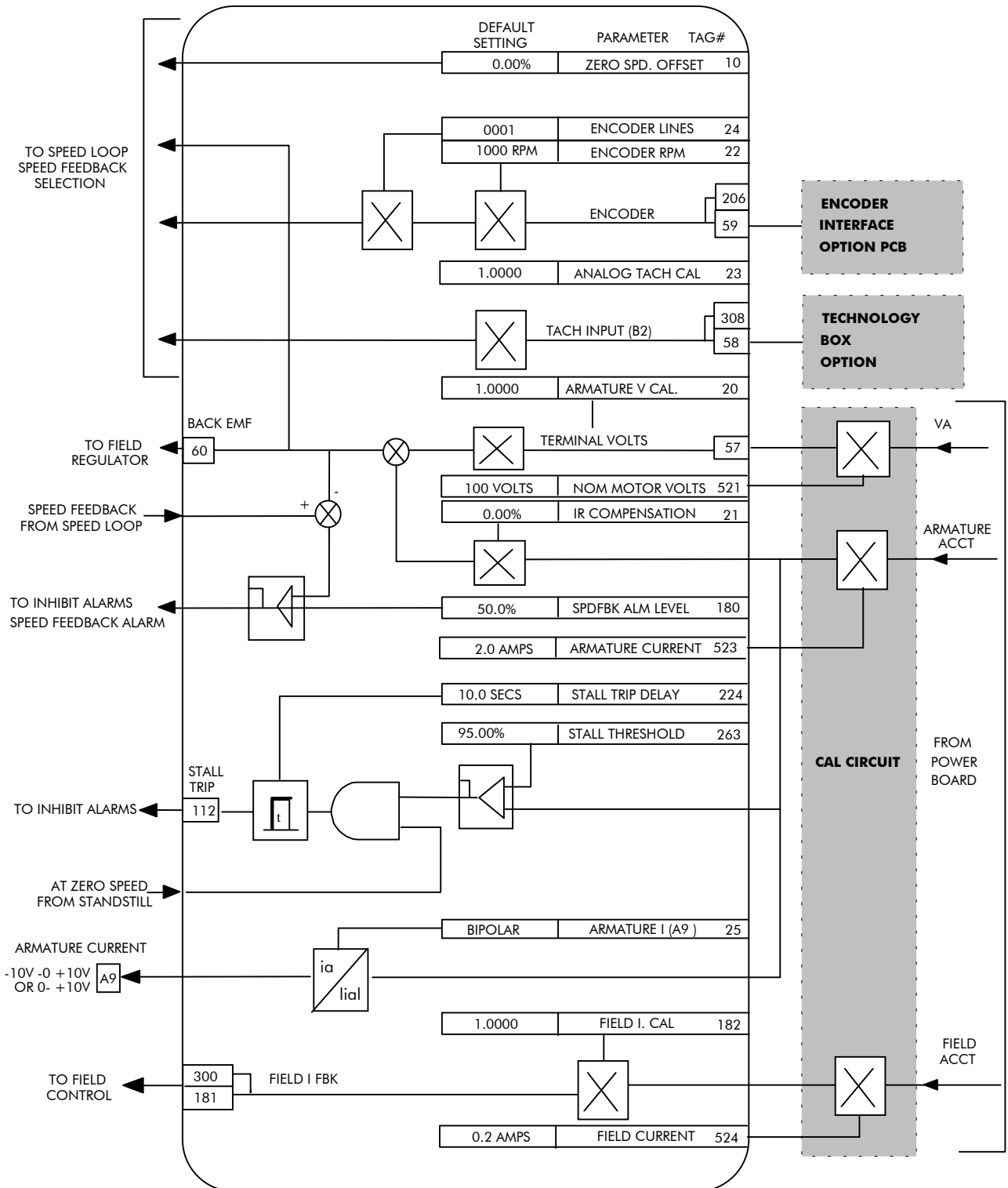

MMI Menu Map

1	CONFIGURE DRIVE
	CONFIGURE ENABLE
	NOM MOTOR VOLTS
	ARMATURE CURRENT
	FIELD CURRENT
	FLD. CTRL MODE
	FLD. VOLTS RATIO
	MAIN CURR. LIMIT
	AUTOTUNE
	SPEED FBK SELECT
	ENCODER LINES
	ENCODER RPM
	ENCODER SIGN
	SPD. INT. TIME
	SPD. PROP. GAIN

CONFIGURE DRIVE (MMI only)

This MMI menu contains many of the parameters required for configuring the drive.

CONFIGURE ENABLE: The operation of the Block Diagram is suspended and all Operator Station LEDs will flash whilst CONFIGURE ENABLE = TRUE.

Note: *The CONFIGURE ENABLE parameter is also available in the following MMI menus for ease of use:*

CALIBRATION
CONFIGURE I/O

Parameter Descriptions

CONFIGURE ENABLE *Tag Number 39* *Range: See below*

Selects Parameterisation Mode (DISABLED) or Configuration Mode (ENABLED). Refer to “Modifying a Block Diagram”, page 6-1.

0 : DISABLED
1 : ENABLED

NOM MOTOR VOLTS

Refer to CALIBRATION, page 6-14.

ARMATURE CURRENT

Refer to CALIBRATION, page 6-14.

FIELD CURRENT

Refer to CALIBRATION, page 6-14.

FLD. CTRL MODE

Refer to FIELD CONTROL, page 6-32.

FLD. VOLTS RATIO

Refer to FIELD CONTROL, page 6-32.

MAIN CURR. LIMIT

Refer to CURRENT LOOP, page 6-18.

AUTOTUNE

Refer to CURRENT LOOP, page 6-18.

SPEED FBK SELECT

Refer to SPEED LOOP, page 6-59.

ENCODER LINES

Refer to CALIBRATION, page 6-14.

ENCODER RPM

Refer to CALIBRATION, page 6-14.

ENCODER SIGN

Refer to SPEED LOOP, page 6-59.

SPD. INT. TIME

Refer to SPEED LOOP, page 6-59.

SPD. PROP. GAIN

Refer to SPEED LOOP, page 6-59.

6-18 Programming Your Application

CURRENT LOOP

This function block allows user parameterisation of the conventional current/torque loop of the converter.

MMI Menu Map

1	SETUP PARAMETERS
2	CURRENT LOOP
	MAIN CURR. LIMIT
	PROP. GAIN
	INT. GAIN
	AUTOTUNE
	FEED FORWARD
	DISCONTINUOUS
	ADDITIONAL DEM
	BIPOLAR CLAMPS
	REGEN MODE
	MASTER BRIDGE
	POS. I CLAMP
	NEG. I CLAMP
	I DMD. ISOLATE
	CUR. LIMIT/SCALER

MMI Menu Map

1	CONFIGURE DRIVE
	AUTOTUNE
	MAIN CURR. LIMIT

Current Loop		
-	AT CURRENT LIMIT [42]	FALSE
-	IA DEMAND [66]	0.00 %
-	IA FEEDBACK [65]	0.00 %
-	IA FEEDBACK [538]	0.0 AMPS
-	IF FEEDBACK [539]	0.0 AMPS
-	AUTOTUNE [18]	OFF
-	ILOOP SUSPEND [46]	FALSE
-	MASTER BRIDGE [527]	OFF
200.00 %	[421] MAIN CURR. LIMIT	-
45.00	[16] PROP GAIN	-
3.50	[17] INT. GAIN	-
2.00	[136] FEED FORWARD	-
12.00 %	[137] DISCONTINUOUS	-
0.00 %	[30] ADDITIONAL DEM	-
DISABLED	[90] BIPOLAR CLAMPS	-
4Q (REGEN)	[201] REGEN MODE	-
100.00 %	[301] POS. I CLAMP	-
-100.00 %	[48] NEG. I CLAMP	-
DISABLED	[119] I DMD. ISOLATE	-
100.00 %	[15] CUR. LIMIT/SCALER	-

Parameter Descriptions

AT CURRENT LIMIT

Range: See below

Refer to the *DIAGNOSTICS* function block description, page 6-22.

- 0 : FALSE
- 1 : TRUE

IA DEMAND

Range: xxx.xx % (h)

(IaDmd UNFILTERED)

Refer to the *DIAGNOSTICS* function block description, page 6-22.

IA FEEDBACK

Range: xxx.xx % (h)

(IaFbk UNFILTERED)

Refer to the *DIAGNOSTICS* function block description, page 6-22.

IA FEEDBACK

Range: xxxx.x AMPS

(CURRENT FBK.AMPS)

Refer to the *DIAGNOSTICS* function block description, page 6-22.

IF FEEDBACK

Range: xxxx.x AMPS

(FIELD I FBK.AMPS)

Refer to the *DIAGNOSTICS* function block description, page 6-22.

AUTOTUNE

Range: See below

This is the autotune function trigger input.

- 0 : OFF
- 1 : ON

ILOOP SUSPEND

Range: See below

Reserved parameter for use by Eurotherm Drives.

- 0 : FALSE
- 1 : TRUE

MASTER BRIDGE

Range: See below

A diagnostic indicating currently active bridge; master = ON, slave = OFF.

- 0 : OFF
- 1 : ON

MAIN CURR. LIMIT

Range: 0.00 to 200.00 %

Main current limit parameter which is independent of current limit scaler and in series with the other three current limit blocks.

PROP GAIN

Range: 0.00 to 200.00

(PROP. GAIN)

Proportional gain control for armature current PI loop. This parameter is set during the autotune function.

INT. GAIN

Range: 0.00 to 200.00

Integral gain control for armature current PI loop. This parameter is set during the autotune function.

FEED FORWARD

Range: 0.10 to 50.00

Set by Autotune but not used by the default I-Loop mode.

DISCONTINUOUS

Range: 0.00 to 200.00 %

Discontinuous-to-continuous mean armature current boundary level. This parameter is set during the autotune function and affects the performance of the adaptive algorithm.

ADDITIONAL DEM

Range: -200.00 to 200.00 %

Additional current demand input.

BIPOLAR CLAMPS

Range: See below

Select input for bipolar (asymmetric) or unipolar (symmetric) current clamps for the 4 quadrants of operation. Default setting of DISABLED means UNIPOLAR clamps selected.

- 0 : DISABLED
- 1 : ENABLED

REGEN MODE

Range: See below

Select input for regenerative (4-quadrant) or non-regenerative (2-quadrant) mode of operation.

Note: We recommend that this parameter is not changed whilst the machine is running.

- 0 : 2Q (NON-REGEN)
- 1 : 4Q (REGEN)

POS. I CLAMP

Range: -100.00 to 100.00 %

Positive current clamp in Bipolar Clamp mode.

NEG. I CLAMP

Range: -100.00 to 100.00 %

Negative current clamp in Bipolar Clamp mode.

Note on bipolar current clamps: these clamps in bipolar mode can cross-over onto the same quadrant as long as the POS. I CLAMP is always greater (algebraically) than the NEG. I CLAMP.

I DMD. ISOLATE

Range: See below

Speed loop bypass; the current demand is taken from ANIN 2 (A3).

The simplified diagram below shows how the I DMD ISOLATE parameter selects the controlling loop.

- 0 : DISABLED
- 1 : ENABLED

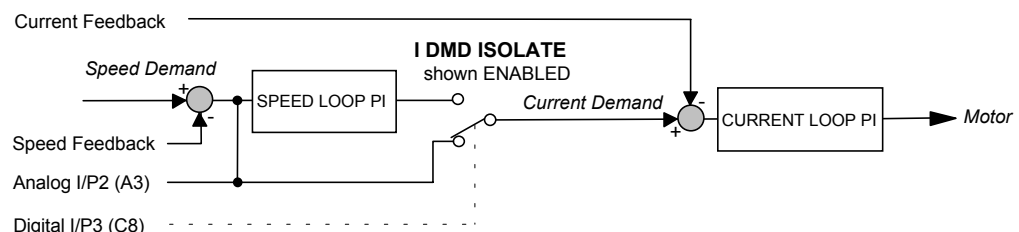

CUR. LIMIT/SCALER

Range: 0.00 to 200.00 %

(CUR.LIMIT/SCALER)

Current limit scaler. It scales bipolar/unipolar clamps.

6-20 Programming Your Application

Functional Description

CURRENT LOOP

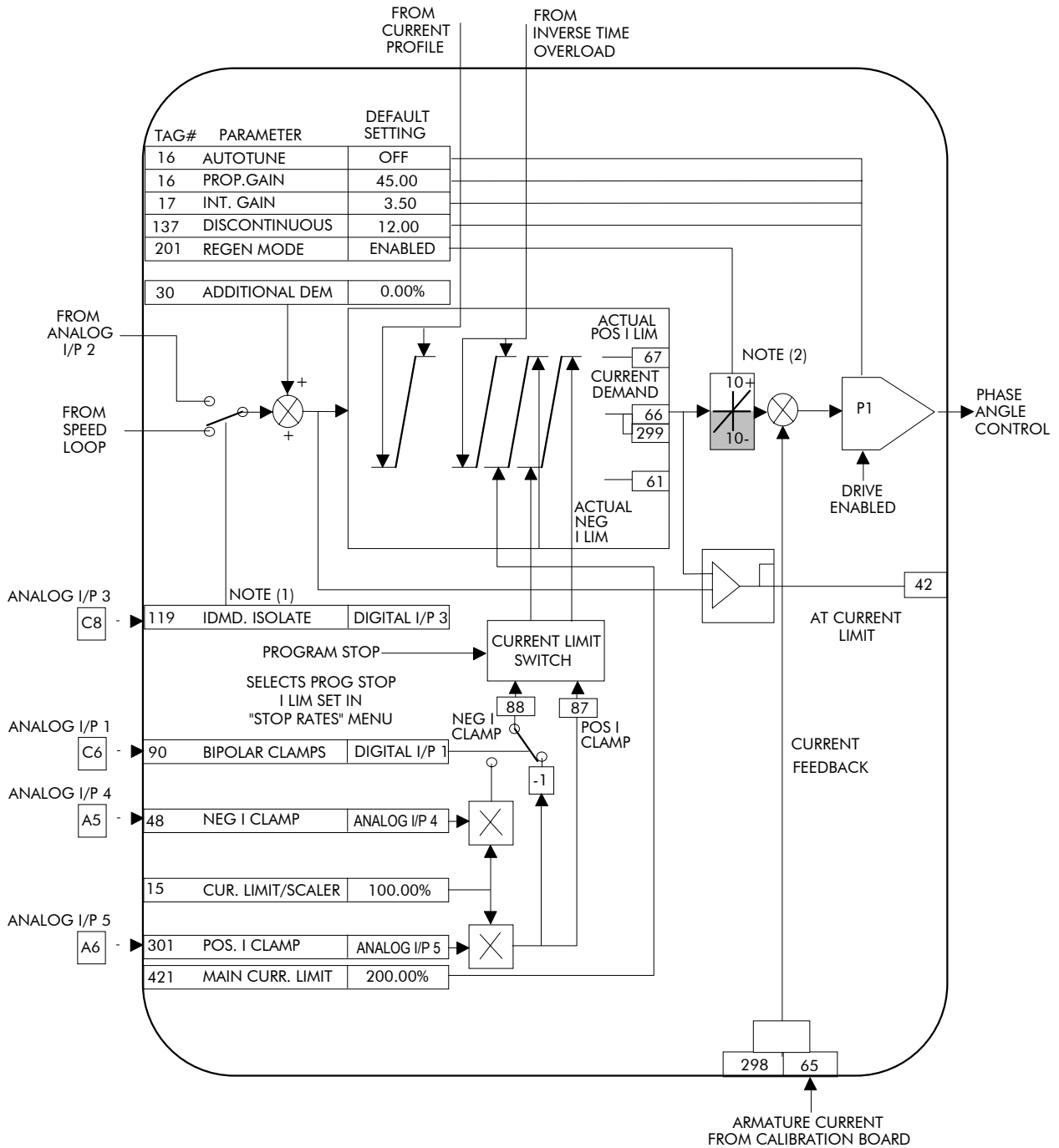

Note 1: IDMD isolate removes speed loop demand and selects analog I/P 2 as current regulator demand. IDMD isolate is overridden by program stop and stop to return drive to speed regulation.

Note 2: Regen mode disable prevents negative current demand. Non-regenerative drives should have regen mode disabled.

MMI Menu Map

- 1 SETUP PARAMETERS
- 2 CURRENT PROFILE
 - SPD BRK1 (LOW)
 - SPD BRK2 (HIGH)
 - IMAX BRK1 (SPD1)
 - IMAX BRK2 (SPD2)

CURRENT PROFILE

When speed control is obtained by field weakening, the ability of the motor to commutate armature current is reduced at low field currents. Also some motors exhibit commutation limitations at higher speeds even with rated field current.

Current Profile	
100.00 %	[32] SPD BRK 1 (LOW)
100.00 %	[31] SPD BRK 2 (HIGH)
200.00 %	[93] IMAX BRK 1 (SPD1)
200.00 %	[33] IMAX BRK 2 (SPD2)

Parameter Descriptions

SPD BRK 1 (LOW)

Range: 0.00 to 100.00 % (h)

(SPD BRK1 (LOW))

This is the motor speed at which current limit profiling begins.

SPD BRK 2 (HIGH)

Range: 0.00 to 100.00 % (h)

(SPD BRK2 (HIGH))

This is the upper speed limit at which current limit profiling ends.

IMAX BRK 1 (SPD1)

Range: 0.00 to 200.00 % (h)

(IMAX BRK1 (SPD1))

This sets the current limit value at or below speed break-point 1, provided the other current limits are greater than this setting.

IMAX BRK 2 (SPD2)

Range: 0.00 to 200.00 % (h)

(IMAX BRK2 (SPD2))

This sets the current limit value at or above speed break-point 2, provided the other current limits are greater than this setting.

Functional Description

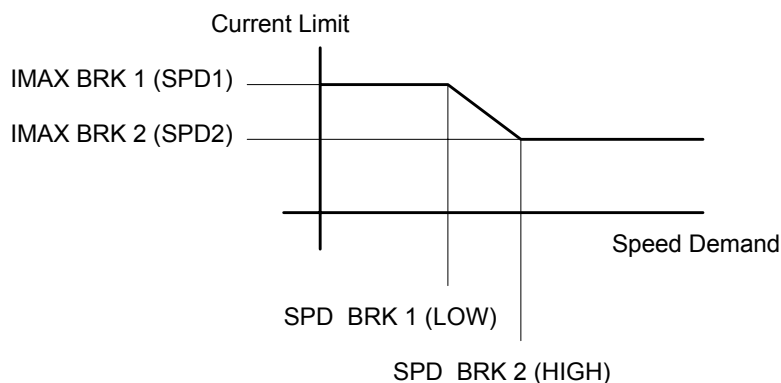

DIAGNOSTICS

MMI Menu Map

1	DIAGNOSTICS
	SPEED DEMAND
	SPEED FEEDBACK
	SPEED ERROR
	SPD LOOP OUTPUT
	CURRENT DEMAND
	CURRENT FEEDBACK
	CURRENT FBK AMPS
	IABFK UNFILTERED
	IADMD UNFILTERED
	POS. I CLAMP
	NEG. I CLAMP
	ACTUAL POS I LIM
	ACTUAL NEG I LIM
	INVERSE TIME O/P
	AT CURRENT LIMIT
	AT ZERO SPEED
	AT ZERO SETPOINT
	AT STANDSTILL
	RAMPING
	PROGRAM STOP
	COAST STOP
	DRIVE START
	DRIVE ENABLE
	OPERATING MODE
	FIELD ENABLED
	FIELD DEMAND
	FIELD I FBK.
	FIELD I FBK. AMPS
	RAW FIELD FBK
	FLD. FIRING ANGLE
	ANIN 1 (A2)
	ANIN 2 (A3)
	ANIN 3 (A4)
	ANIN 4 (A5)
	ANIN 5 (A6)
	ANOUT 1 (A7)
	ANOUT 2 (A8)
	START (C3)
	DIGITAL INPUT C4
	DIGITAL INPUT C5
	DIGIN 1 (C6)
	DIGIN 2 (C7)
	DIGIN 3 (C8)
	DIGOUT 1 (B5)
	DIGOUT 2 (B6)
	DIGOUT 3 (B7)
	RAISE/LOWER O/P
	PID OUTPUT
	PID CLAMPED
	PID ERROR
	SPT SUM OUTPUT
	RAMP OUTPUT
	SPEED SETPOINT
	TERMINAL VOLTS
	BACK EMF
	TACH INPUT (B2)
	RAW TACH INPUT
	ENCODER
	RAW ENCODER RPM

MMI Menu Map cont.

1	DIAGNOSTICS
	RAW SPEED FBK
	RAW SPEED ERROR
	CONTACTOR CLOSED
	HEALTH LED
	READY
	DRIVE RUNNING
	SYSTEM RESET

This function block is used to monitor the status of the drive, internal variables, and its inputs and outputs.

The Parameter Descriptions table on this page describes the parameters contained in the DIAGNOSTICS function block.

The MMI DIAGNOSTICS Menu listing on the next page describes all the parameters in the MMI's DIAGNOSTICS menu, with references in brackets where parameters appear in other function blocks.

Parameter Descriptions

SPEED FEEDBACK	<i>Range: xxx.xx %</i>
Speed loop feedback. (Refer to <i>SPEED LOOP</i> , page 6-59)	
SPEED ERROR	<i>Range: xxx.xx %</i>
Speed loop error. (<i>DIAGNOSTIC only</i>)	
CURRENT DEMAND	<i>Range: xxx.xx %</i>
Current loop demand (speed error PI output or external current demand clamped by all the current limits). (<i>DIAGNOSTIC only</i>)	
CURRENT FEEDBACK	<i>Range: xxx.xx %</i>
Scaled and filtered armature current. (<i>DIAGNOSTIC only</i>)	
POS. I CLAMP	<i>Range: xxx.xx % (h)</i>
Positive current clamp. (<i>DIAGNOSTIC only</i>)	
NEG. I CLAMP	<i>Range: xxx.xx % (h)</i>
Negative current clamp. (<i>DIAGNOSTIC only</i>)	
ACTUAL POS I LIM	<i>Range: xxx.xx % (h)</i>
Overall positive current limit value. (<i>DIAGNOSTIC only</i>)	
ACTUAL NEG I LIM	<i>Range: xxx.xx % (h)</i>
Overall negative current limit value. (<i>DIAGNOSTIC only</i>)	
DRIVE START	<i>Range: See below</i>
Controller start/run command. (<i>DIAGNOSTIC only</i>)	
	0 : OFF
	1 : ON
DRIVE ENABLE	<i>Range: See below</i>
Drive speed and current loop are enabled/quenched. (<i>DIAGNOSTIC only</i>)	
	0 : DISABLED
	1 : ENABLED
FIELD I FBK.	<i>Range: xxx.xx %</i>
Scaled field current feedback. (<i>DIAGNOSTIC only</i>)	
TACH INPUT (B2)	<i>Range: xxx.xx % (h)</i>
Scaled analog tachogenerator feedback. (<i>DIAGNOSTIC only</i>)	
ENCODER	<i>Range: xxxxx RPM</i>
Encoder speed feedback in RPM. (<i>DIAGNOSTIC only</i>)	

Diagnostics		
-	SPEED FEEDBACK [207]	0.00 %
-	SPEED ERROR [297]	0.00 %
-	CURRENT DEMAND [299]	0.00 %
-	CURRENT FEEDBACK [298]	0.00 %
-	POS. I CLAMP [87]	0.00 %
-	NEG. I CLAMP [88]	0.00 %
-	ACTUAL POS I LIM [67]	0.00 %
-	ACTUAL NEG I LIM [61]	0.00 %
-	DRIVE START [82]	OFF
-	DRIVE ENABLE [84]	DISABLED
-	FIELD I FBK. [300]	0.00 %
-	TACH INPUT (B2) [308]	0.00 %
-	ENCODER [206]	0 RPM

The MMI DIAGNOSTICS Menu

SPEED DEMAND Speed loop total setpoint after the ramp-to-zero block. <i>(Refer to STOP RATES, page 6-65)</i>	Tag No. 89	xxx.xx%
SPEED FEEDBACK Speed loop feedback. <i>(Refer to SPEED LOOP, page 6-59)</i>	Tag No. 207	xxx.xx%
SPEED ERROR Speed loop error. <i>(Refer to SPEED LOOP, page 6-59)</i>	Tag No. 297	xxx.xx%
SPEED LOOP OUTPUT Output from speed loop PI. <i>(Refer to SPEED LOOP, page 6-59)</i>	Tag No. 356	xxx.xx%
CURRENT DEMAND Current loop demand (speed error PI output or external current demand clamped by all the current limits). <i>(DIAGNOSTIC only)</i>	Tag No. 299	xxx.xx%
CURRENT FEEDBACK Scaled and filtered armature current. <i>(DIAGNOSTIC only)</i>	Tag No. 298	xxx.xx%
CURRENT FBK. AMPS Scaled and filtered armature current in Amps. <i>(Refer to CONFIGURE DRIVE (MMI only), page 6-17)</i>	Tag No. 538	xxx.xx AMPS
IaFBK UNFILTERED Scaled armature current. <i>(Refer to CONFIGURE DRIVE (MMI only), page 6-17)</i>	Tag No. 65	xxx.xx%
IaDmd UNFILTERED Scaled demanded armature current. <i>(Refer to CONFIGURE DRIVE (MMI only), page 6-17)</i>	Tag No. 66	xxx.xx%
POS I CLAMP Positive current clamp. <i>(DIAGNOSTIC only)</i>	Tag No. 87	xxx.xx%
NEG I CLAMP Negative current clamp. <i>(DIAGNOSTIC only)</i>	Tag No. 88	xxx.xx%
ACTUAL POS I LIM Overall positive current limit value. <i>(DIAGNOSTIC only)</i>	Tag No. 67	xxx.xx%
ACTUAL NEG I LIM Overall negative current limit value. <i>(DIAGNOSTIC only)</i>	Tag No. 61	xxx.xx%
INVERSE TIME O/P Inverse time clamp output level. <i>(Reference to INVERSE TIME - reserved menu)</i>	Tag No. 203	xxx.xx%
AT CURRENT LIMIT Current demand is being restrained by the overall current limit. <i>(Refer to CONFIGURE DRIVE (MMI only), page 6-17)</i>	Tag No. 42	FALSE /TRUE
AT ZERO SPEED At zero speed feedback. <i>(Refer to STANDSTILL, page 6-64)</i>	Tag No. 77	FALSE /TRUE
AT ZERO SETPOINT At zero speed demand. <i>(Refer to STANDSTILL, page 6-64)</i>	Tag No. 78	FALSE /TRUE

6-24 Programming Your Application

AT STANDSTILL AT ZERO SPEED and AT ZERO SETPOINT. <i>(Refer to STANDSTILL, page 6-64)</i>	Tag No. 79	FALSE /TRUE
RAMPING If the difference between the ramp input and the ramp output is greater than the RAMP THRESHOLD, then RAMPING is TRUE. <i>(Refer to RAMPS, page 6-52)</i>	Tag No. 113	FALSE /TRUE
PROGRAM STOP State of program stop (Terminal B8). When B8 is at 24V, then PROGRAM STOP is FALSE and the program stop front panel LED is also ON. <i>(Refer to STOP RATES, page 6-65)</i>	Tag No. 80	FALSE /TRUE
COAST STOP State of coast stop (Terminal B9). When B9 is at 24V, then COAST STOP is FALSE. <i>(DIAGNOSTIC only)</i>	Tag No. 525	FALSE /TRUE
DRIVE START Controller start/run command. <i>(DIAGNOSTIC only)</i>	Tag No. 82	ON/OFF
DRIVE ENABLE Drive speed and current loop are enabled/quenched. <i>(DIAGNOSTIC only)</i>	Tag No. 84	ENABLED/DISABLED
OPERATING MODE Indicates whether the drive is in RUN, JOG 1....STOP etc. 0 : STOP 1 : STOP 2 : JOG SP. 1 3 : JOG SP. 2 4 : RUN 5 : TAKE UP SP. 1 6 : TAKE UP SP. 2 7 : CRAWL <i>(Refer to JOG/SLACK, page 6-38)</i>	Tag No. 212	0 to 7
FIELD ENABLED Drive field loop is enabled/quenched. <i>(Refer to FIELD CONTROL, page 6-32)</i>	Tag No. 169	ENABLED/DISABLED
FIELD DEMAND The meaning of field demand depends upon which mode of field control is in force; in current control FIELD DEMAND is the current setpoint to the field loop, in voltage mode FIELD DEMAND is the voltage ratio to the field controller. <i>(Refer to FIELD CONTROL, page 6-32)</i>	Tag No. 183	xxx.xx%
FIELD I FBK Scaled and filtered field current feedback. <i>(DIAGNOSTIC only)</i>	Tag No. 300	xxx.xx%
FIELD I FBK AMPS Scaled and filtered field current feedback in Amps. <i>(Refer to CONFIGURE DRIVE (MMI only), page 6-17)</i>	Tag No. 539	xxxx.x AMPS
RAW FIELD FBK Scaled field current. <i>(Refer to Error! Reference source not found. , page 6-14)</i>	Tag No. 181	xxx.xx%
FLD. FIRING ANGLE Field firing angle in degrees: 155 degrees is the value for back stop (min field) and 5 degrees is the value for front stop (max field). <i>(Refer to FIELD CONTROL, page 6-32)</i>	Tag No. 184	xxx.xx DEG
ANIN 1 (A2) Speed setpoint no. 1. <i>(Refer to ANALOG INPUTS, page 6-5)</i>	Tag No. 50	xxx.xx VOLTS
ANIN 2 (A3) Speed setpoint no. 2/current demand. <i>(Refer to ANALOG INPUTS, page 6-5)</i>	Tag No. 51	xxx.xx VOLTS

ANIN 3 (A4) Speed setpoint no. 3 (ramped).	Tag No. 52	xxx.xx VOLTS
<i>(Refer to ANALOG INPUTS, page 6-5)</i>		
ANIN 4 (A5) Negative current clamp; this is only active if bipolar clamps are enabled (C6 = ON).	Tag No. 53	xxx.xx VOLTS
<i>(Refer to ANALOG INPUTS, page 6-5)</i>		
ANIN 5 (A6) Main current limit or positive current clamp if C6 = ON.	Tag No. 54	xxx.xx VOLTS
<i>(Refer to ANALOG INPUTS, page 6-5)</i>		
ANOUT 1 (A7) Scaled speed feedback.	Tag No. 55	xxx.xx VOLTS
<i>(Refer to ANALOG OUTPUTS, page 6-7)</i>		
ANOUT 2 (A8) Total speed setpoint.	Tag No. 56	xxx.xx VOLTS
<i>(Refer to ANALOG OUTPUTS, page 6-7)</i>		
START (C3) Start/Run terminal.	Tag No. 68	ON/OFF
<i>(Refer to AUX I/O, page 6-8)</i>		
DIGITAL INPUT C4 Jog/Take-up Slack terminal.	Tag No. 69	ON/OFF
<i>(Refer to DIGITAL INPUTS, page 6-29 and AUX I/O, page 6-8)</i>		
DIGITAL INPUT C5 Electronic enable/quench terminal (ON = Enabled).	Tag No. 70	ON/OFF
<i>(Refer to DIGITAL INPUTS, page 6-29 and AUX I/O, page 6-8)</i>		
DIGIN 1 (C6) Symmetrical current clamps/Asymmetrical (bipolar) current clamps (ON = Bipolar).	Tag No. 71	ON/OFF
<i>(Refer to DIGITAL INPUTS, page 6-29)</i>		
DIGIN 2 (C7) Ramp hold input (ON = Hold).	Tag No. 72	ON/OFF
<i>(Refer to DIGITAL INPUTS, page 6-29)</i>		
DIGIN 3 (C8) Current demand isolate; giving speed or current mode of operation. (ON = Current mode).	Tag No. 73	ON/OFF
<i>(Refer to DIGITAL INPUTS, page 6-29)</i>		
DIGOUT 1 (B5) At zero speed.	Tag No. 74	ON/OFF
<i>(Refer to DIGITAL OUTPUTS, page 6-31)</i>		
DIGOUT 2 (B6) Drive healthy. Health is also displayed on the front panel LED, always ON when the start is low.	Tag No. 75	ON/OFF
<i>(Refer to DIGITAL OUTPUTS, page 6-31)</i>		
DIGOUT 3 (B7) Drive ready to run (all alarms healthy and mains synchronisation achieved)	Tag No. 76	ON/OFF
<i>(Refer to DIGITAL OUTPUTS, page 6-31)</i>		
RAISE/LOWER O/P (OUTPUT) Value of the raise/lower ramp function.	Tag No. 264	xxx.xx%
<i>(Refer to RAISE/LOWER, page 6-50)</i>		
PID OUTPUT PID block output.	Tag No. 417	xxx.xx%
<i>(Refer to PASSWORD (MMI only), page 6-46)</i>		
PID CLAMPED Logic output indicating whether the PID limits are active.	Tag No. 416	FALSE /TRUE
<i>(Refer to PASSWORD (MMI only), page 6-46)</i>		
PID ERROR PID error = Input 1 - Input 2	Tag No. 415	xxx.xx%
<i>(Refer to PASSWORD (MMI only), page 6-46)</i>		

6-26 Programming Your Application

SPT SUM OUTPUT Setpoint sum 1 output.	Tag No. 86	xxx.xx%
	<i>(Refer to SETPOINT SUM 1, page 6-56)</i>	
RAMP OUTPUT Setpoint ramp output.	Tag No. 85	xxx.xx%
	<i>(Refer to RAMPS, page 6-52)</i>	
SPEED SETPOINT Speed loop total setpoint including the ramp output before the ramp-to-zero function.	Tag No. 63	xxx.xx%
	<i>(Refer to SPEED LOOP, page 6-59)</i>	
TERMINAL VOLTS Scaled terminal volts.	Tag No. 57	xxx.xx%
	<i>(Refer to BLOCK DIAGRAM (MMI only), page 6-13)</i>	
BACK EMF Calculated motor back EMF including IR. compensation.	Tag No. 60	xxx.xx%
	<i>(Refer BLOCK DIAGRAM (MMI only), page 6-13)</i>	
TACH INPUT (B2) Scaled analog tachogenerator feedback.	Tag No. 308	xxx.xx%
	<i>(DIAGNOSTIC only)</i>	
RAW TACH INPUT Unfiltered analog tachogenerator feedback.	Tag No. 58	xxx.xx%
	<i>(Refer to BLOCK DIAGRAM (MMI only), page 6-13)</i>	
ENCODER Encoder speed feedback in RPM.	Tag No. 206	xxxxx RPM
	<i>(DIAGNOSTIC only)</i>	
RAW ENCODER RPM Unfiltered encoder speed feedback in RPM.	Tag No. 59	xxxxx RPM
	<i>(Refer to BLOCK DIAGRAM (MMI only), page 6-13)</i>	
RAW SPEED FBK Unfiltered speed feedback.	Tag No. 62	xxx.xx%
	<i>(Refer to SPEED LOOP, page 6-59)</i>	
RAW SPEED ERROR Unfiltered speed error.	Tag No. 64	xxx.xx%
	<i>(Refer to SPEED LOOP, page 6-59)</i>	
CONTACTOR CLOSED Main contactor control signal.	Tag No. 83	ON/OFF
	<i>(DIAGNOSTIC only)</i>	
HEALTH LED State of Health LED on Operator Station.	Tag No. 122	FALSE/ TRUE
	<i>(Refer to ALARMS, page 6-35)</i>	
READY The drive is ready to accept an enable signal.	Tag No. 125	FALSE/ TRUE
	<i>(Refer to ALARMS, page 6-35)</i>	
DRIVE RUNNING Drive is enabled and may make current when TRUE. A diagnostic for those parameters that can only be written to when the drive is stopped (parameters marked with Note 2 in the Parameter Specification Table).	Tag No. 376	FALSE/ TRUE
	<i>(DIAGNOSTIC only)</i>	
SYSTEM RESET Set for one cycle as the drive is enabled.	Tag No. 374	FALSE/ TRUE
	<i>(DIAGNOSTIC only)</i>	

MMI Menu Map

- 1 **SETUP PARAMETERS**
- 2 **SPECIAL BLOCKS**
- 3 **DIAMETER CALC.**
 - LINE SPEED
 - REEL SPEED
 - MIN DIAMETER
 - MIN SPEED
 - RESET VALUE
 - EXTERNAL RESET
 - RAMP RATE
 - DIAMETER
 - MOD OF LINE SPD
 - MOD OF REEL SPD
 - UNFILT DIAMETER

DIAMETER CALC.

This block calculates the diameter of a reel as a function of the reel speed and the line speed.

Diameter Calc.		
-	DIAMETER	[427] 0.00 %
-	MOD OF LINE SPEED	[428] 0.00 %
-	MOD OF REEL SPEED	[429] 0.00 %
-	UNFILTERED DIAMETER	[430] 0.00 %
0.00 %	[424] LINE SPEED	
0.00 %	[437] REEL SPEED	
10.00 %	[425] MIN DIAMETER	
5.00 %	[426] MIN SPEED	
10.00 %	[462] RESET VALUE	
DISABLED	[463] EXTERNAL RESET	
5.0 SECS	[453] RAMP RATE	

Parameter Descriptions

DIAMETER

Range: xxx.xx %

This is the output of the block and it can be connected to the appropriate points in the winder block.

MOD OF LINE SPEED

Range: xxx.xx %

(MOD OF LINE SPD)

Modulus of line speed.

MOD OF REEL SPEED

Range: xxx.xx %

(MOD OF REEL SPD)

Modulus of reel speed.

UNFILTERED DIAMETER

Range: xxx.xx %

(UNFILT DIAMETER)

Unfiltered value of “diameter”.

LINE SPEED

Range: -105.00 to 105.00 %

This will usually be configured to be the analog tacho input and scaled appropriately during calibration.

REEL SPEED

Range: -105.00 to 105.00 %

This will usually be configured to be the drive's own speed feedback, i.e. encoder or arm.volts feedback

MIN DIAMETER

Range: 0.00 to 100.00 %

This is normally the empty core diameter.

MIN SPEED

Range: 0.00 to 100.00 %

This is the minimum LINE SPEED level below which the diameter calculation is frozen.

RESET VALUE

Range: 0.00 to 100.00 %

Normally for winders this will be set to the MIN DIAMETER value. This value will be preloaded into the ramp (filter) output when EXTERNAL RESET is enabled.

EXTERNAL RESET

Range: See below

Whilst this input is being enabled the ramp is held at the RESET VALUE.

- 0 : DISABLED
- 1 : ENABLED

RAMP RATE

Range: 0.1 to 600.0 SECS

This is used to filter the output of the diameter calculator.

6-28 Programming Your Application

Functional Description

DIAMETER CALC.

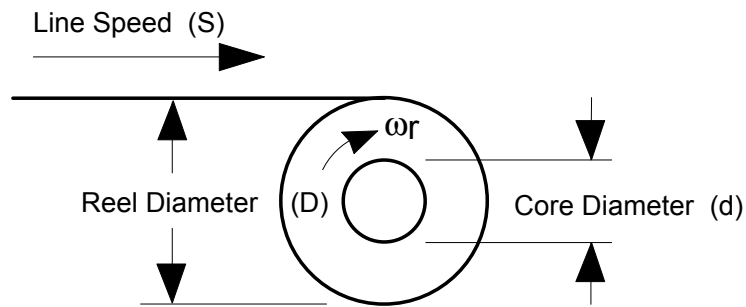
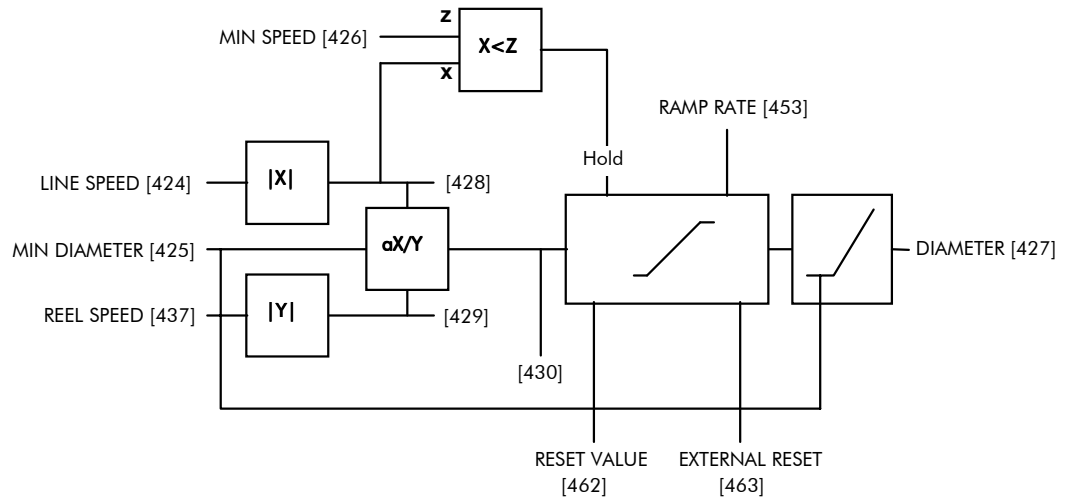

Circumference = πD or Line Speed (S) = Reel Speed (ωr) x D

Thus $D = \frac{S}{\omega r}$

i.e. $D \propto \frac{\text{Line Speed (S)}}{\text{Reel Speed } (\omega r)}$

Therefore with the web intact we can calculate the diameter from the two speeds

DIGITAL INPUTS

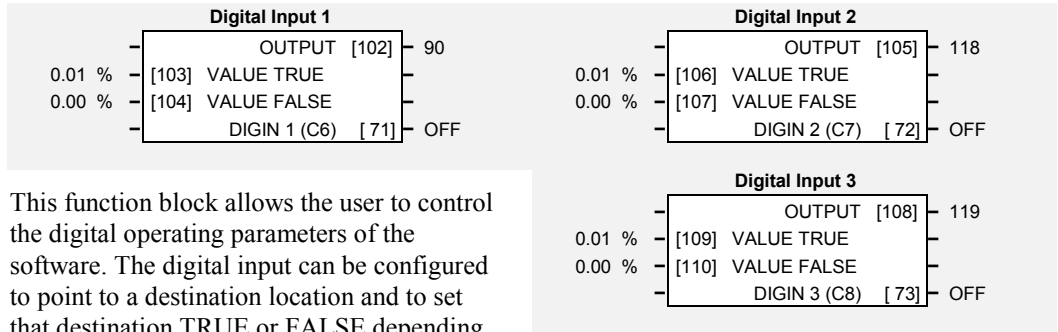
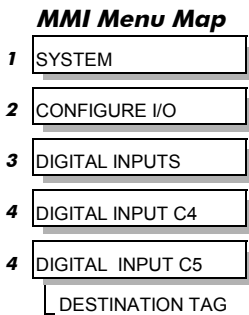
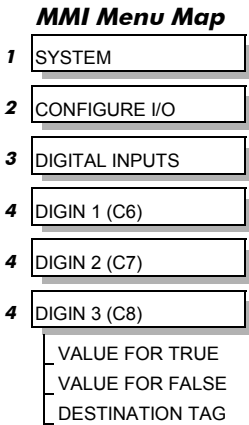

This function block allows the user to control the digital operating parameters of the software. The digital input can be configured to point to a destination location and to set that destination TRUE or FALSE depending upon programmable values.

Parameter Descriptions

OUTPUT

(DESTINATION TAG)

The destination Tag No. of the assumed value. Refer to “Special Links”, page 6-1.

Range: 0 to 549

VALUE TRUE

(VALUE FOR TRUE)

The value that OUTPUT assumes when input is TRUE.

Range: -300.00 to 300.00 %

VALUE FALSE

(VALUE FOR FALSE)

The value that OUTPUT assumes when input is FALSE.

Range: -300.00 to 300.00 %

DIGIN 1 (C6) to DIGIN 3 (C8)

Refer to the *DIAGNOSTICS* function block description, page 6-22.

Range: See below

0 : OFF
1 : ON

Functional Description

The destination for a digital input can be any valid Tag No, this means that a digital input can be used to select one of two values for a given parameter. It is also possible to treat the values for TRUE and FALSE as destination tags from other functions or inputs.

With regard to destinations expecting logic parameters, 0.00% is regarded as Logic 0 and any other value is regarded as Logic 1. This refers to the values set in both VALUE TRUE and VALUE FALSE.

Inverting the digital input is therefore simple; set VALUE TRUE to 0.00% and VALUE FALSE to 0.01% or any other non-zero number.

Configurable Digital Inputs

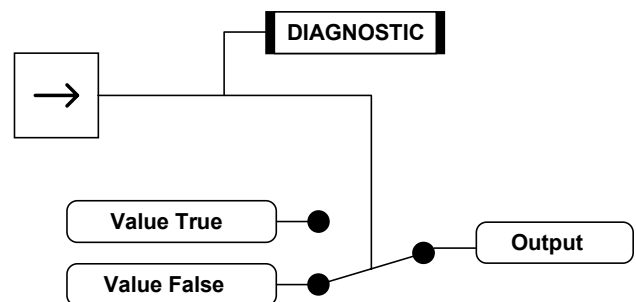

6-30 Programming Your Application

Additional Inputs

It is possible to use an Analog Input as a Digital Input to extend the number of Digital Inputs available. Again, 0.00% is regarded as Logic 0 and any other value is regarded as Logic 1.

Using Analog I/P as Digital I/P

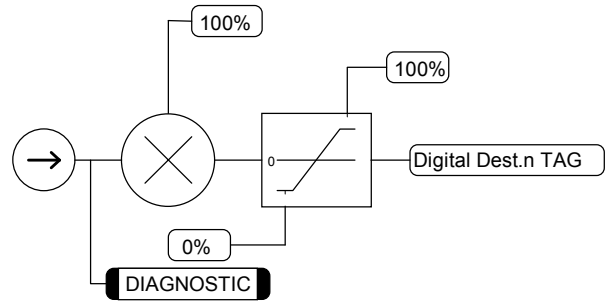

DIGITAL INPUT C4 and DIGITAL INPUT C5

Digital Inputs C4 and C5 have DESTINATION TAGs only. They do not support VALUE TRUE and VALUE FALSE, (VALUE TRUE is fixed at 0.01%, and VALUE FALSE is fixed at 0.00%).

DIGITAL INPUT C4

Refer to the *DIAGNOSTICS* function block description, page 6-22.

Only the OUTPUT (DESTINATION TAG) parameter of this digital input can be configured. By default it is set to 496, which is the Tag No. for JOG/SLACK in the AUX I/O function block.

DESTINATION TAG

Destination of DIGITAL INPUT C4

Range: 0 to 549
Default: 496
TAG N°: 494

DIGITAL INPUT C5

Refer to the *DIAGNOSTICS* function block description, page 6-22.

Only the OUTPUT (DESTINATION TAG) parameter of this digital input can be configured. By default it is set to 497, which is the Tag No. for ENABLE in the AUX I/O function block.

DESTINATION TAG

Destination of DIGITAL INPUT C5

Range: 0 to 549
Default: 497
TAG N°: 495

If terminal C5 is used for anything other than “drive enable”, i.e. DESTINATION TAG (Tag No. 495) is *not* set to 497, then the ENABLE parameter, Tag No. 497, must be set to ON, otherwise the drive will not run.

DIGITAL OUTPUTS

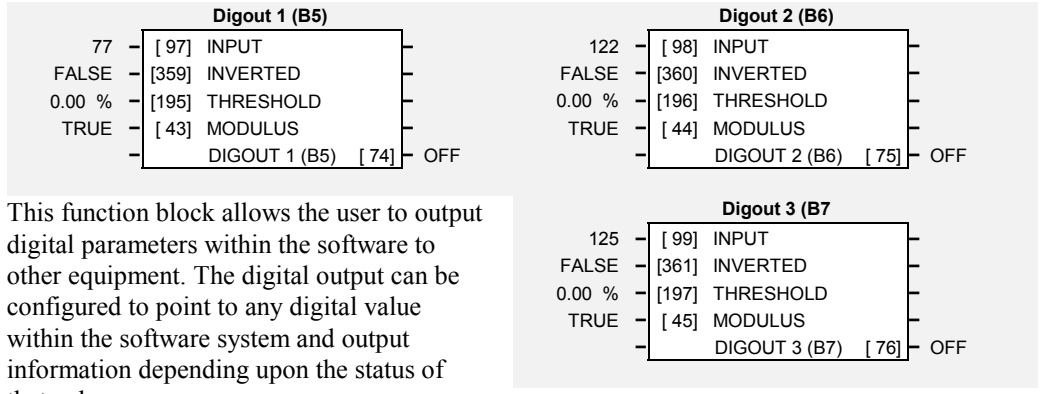
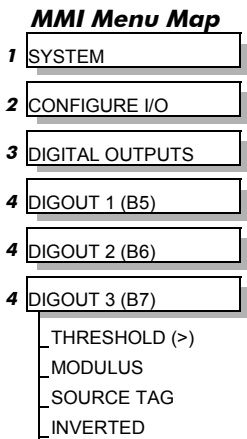

This function block allows the user to output digital parameters within the software to other equipment. The digital output can be configured to point to any digital value within the software system and output information depending upon the status of that value.

Parameter Descriptions

INPUT

Range: 0 to 549

(SOURCE TAG)

Defines the source of the variable to control the digital output. Refer to “Special Links”, page 6-1.

INVERTED

Range: See below

Selects inverted output.

- 0 : FALSE
- 1 : TRUE

THRESHOLD

Range: -300.00 to 300.00 %

(THRESHOLD (>))

The threshold which the value must exceed to set the output to TRUE.

MODULUS

Range: See below

Output set TRUE for absolute or modulus of the Tag No. value.

- 0 : FALSE
- 1 : TRUE

DIGOUT 1 (B5) to DIGOUT 3 (B7)

Range: See below

Refer to the *DIAGNOSTICS* function block description, page 6-22.

- 0 : OFF
- 1 : ON

Functional Description

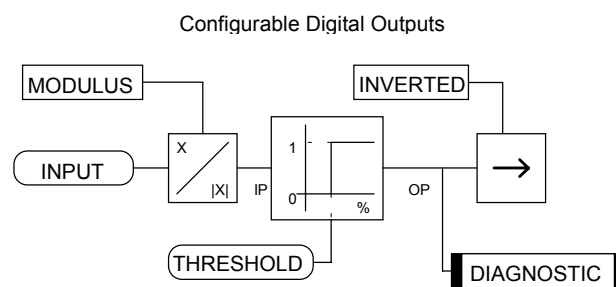

MMI Menu Map

- 1 SETUP PARAMETERS
- 2 FIELD CONTROL
 - FIELD ENABLE
 - FLD CTRL MODE
 - FLD QUENCH DELAY
 - FLD. QUENCH MODE

MMI Menu Map

- 1 SETUP PARAMETERS
- 2 FIELD CONTROL
- 3 FLD VOLTAGE VARS
 - FLD. VOLTS RATIO

MMI Menu Map

- 1 SETUP PARAMETERS
- 2 FIELD CONTROL
- 3 FLD CURRENT VARS
 - SETPOINT
 - PROP. GAIN
 - INT. GAIN

MMI Menu Map

- 1 SETUP PARAMETERS
- 2 FIELD CONTROL
- 3 FLD CURRENT VARS
- 4 FLD WEAK VARS
 - FLD. WEAK ENABLE
 - EMF LEAD
 - EMF LAG
 - EMF GAIN
 - MIN FLD. CURRENT
 - MAX VOLTS
 - BEMF FBK LEAD
 - BEMF FBK LAG

MMI Menu Map

- 1 CONFIGURE DRIVE
 - FLD CTRL MODE
 - FLD. VOLTS RATIO

FIELD CONTROL

This function block contains all the parameters for the field operating mode. It is viewed in three separate menus on the MMI.

In the FIELD CONTROL menu, you select the field operating mode: open loop voltage control or closed loop current control.

FLD VOLTAGE VARS

Contains the parameter for the open loop voltage control mode.

FLD CURRENT VARS

Contains the parameters for the closed loop current control mode.

FLD WEAK VARS

Contains the parameters for the closed loop current control mode.

In certain applications of a DC motor controller, high speeds can only be achieved by reducing the field current and therefore the resultant torque. This is termed as the Constant-Horsepower region or Field-Weakening region, and the speed at which it begins is known as the Base Speed.

Field Control			
-	FIELD ENABLE	[169]	DISABLED
-	FIELD DEMAND	[183]	0.00 %
-	FLD. FIRING ANGLE	[184]	0.00 DEG
ENABLED	[170]	FIELD ENABLE	
VOLTAGE CONTROL	[209]	FLD CTRL MODE IS	
90.00 %	[210]	RATIO OUT/IN	
100.00 %	[171]	SETPOINT	
0.10	[173]	PROP. GAIN	
1.28	[172]	INT. GAIN	
DISABLED	[174]	FLD. WEAK ENABLE	
2.00	[175]	EMF LEAD	
40.00	[176]	EMF LAG	
0.30	[177]	EMF GAIN	
10.00 %	[179]	MIN FIELD CURRENT	
100.00 %	[178]	MAX VOLTS	
100	[191]	BEMF FBK LEAD	
100	[192]	BEMF FBK LAG	
0.0 SECS	[185]	FLD. QUENCH DELAY	
QUENCH	[186]	FLD. QUENCH MODE	

Parameter Descriptions

FIELD ENABLED

Range: See below

Refer to the *DIAGNOSTICS* function block description, page 6-22.

- 0 : DISABLED
- 1 : ENABLED

FIELD DEMAND

Range: xxx.xx %

Refer to the *DIAGNOSTICS* function block description, page 6-22.

FLD. FIRING ANGLE

Range: xxx.xx DEG

(FLD.FIRING ANGLE)

Refer to the *DIAGNOSTICS* function block description, page 6-22.

FIELD ENABLE

Range: See below

Unquenches field current loop.

- 0 : DISABLED
- 1 : ENABLED

FLD CTRL MODE IS

Range: See below

(FLD.CTRL MODE)

There are two field control modes:

- (a) Field Voltage Control is an open loop phase angle control to give a certain voltage output.
- (b) Field Current Control is a closed loop current control for accurate field control or expansion to field weakening.

- 0 : VOLTAGE CONTROL
- 1 : CURRENT CONTROL

RATIO OUT/IN

Range: 0.00 to 100.00 % (h)

(FLD.VOLTS RATIO)

This parameter controls the output voltage from the open loop voltage control. The ratio is defined as the DC output voltage over the AC RMS input voltage.

The default setting is equivalent to a single-phase diode rectifier.

SETPOINT

Range: 0.00 to 100.00 %

Field current setpoint.

PROP. GAIN

Range: 0.00 to 100.00

This is the proportional gain adjustment of the field current PI loop. The default of 0.10 is equivalent to a real gain of 10.

INT. GAIN

Range: 0.00 to 100.00

This is the integral gain adjustment of the field current PI loop.

FLD. WEAK ENABLE

Range: See below

Activates the additional motor back emf PID loop for field weakening (field spillover) control.

0 : DISABLED

1 : ENABLED

EMF LEAD

Range: 0.10 to 50.00

With field weakening control enabled, a PID loop is brought into operation. This is the lead time constant adjustment of the field weakening PID loop.

With a default of 2.00, real time constant = 200ms.

EMF LAG

Range: 0.00 to 200.00

This is the lag time constant adjustment of the field weakening PID loop

With a default of 4.00, real time constant = 4000ms.

EMF GAIN

Range: 0.00 to 100.00

This is the gain adjustment of the field weakening PID loop.

With a default of 3.00, real gain = 30.

MIN FIELD CURRENT

Range: 0.00 to 100.00 %

(MIN FLD.CURRENT)

The field weakening loop reduces the field current to achieve speed control above base speed. At top speed the field reaches a minimum value. The Min Fld Current should be set below this minimum value to allow reasonable margin for transient control near the top speed but not lower than 6% as this could then cause the "Field Fail" alarm to operate.

MAX VOLTS

Range: 0.00 to 100.00 %

Maximum volts is the voltage level at which field weakening begins. It is also known as "Spillover Bias". The default value is 100% of the nominal value as set by the armature voltage calibration value. For commissioning purposes this value can be set to another (lower) desirable level. Subsequently, it is advisable to return it to 100% for normalisation.

BEMF FBK LEAD

Range: 10 to 5000

This is the lead time constant of the back emf feedback filter which is used for reducing armature voltage overshoots when accelerating fast through base speed.

BEMF FBK LAG

Range: 10 to 5000

This is the lag time constant of the above feedback filter. If the filter is active, the ratio of lead / lag should always be greater than 1 to give an overall lead action which reduces the voltage overshoot and less than, typically, 3 for stable control. The default values 100/100 = 1 cancel each other and make the filter inactive.

FLD. QUENCH DELAY

Range: 0.0 to 600.0 SECS

(FLD.QUENCH DELAY)

If dynamic braking is used the field must be maintained for a period after the drive is disabled. The field quench delay is the period of time which the field is maintained for.

FLD. QUENCH MODE

Range: See below

After the field quench delay has expired, the field can be entirely quenched or put into a standby mode at 50% of rated current or volts depending whether in current or voltage control mode respectively. (The default standby value of 50% can be modified through the "SYSTEM / Reserved" Menu which is primarily for factory use only and requires the "super" password.)

0 : QUENCH

1 : STANDBY

6-34 Programming Your Application

FIELD CONTROL

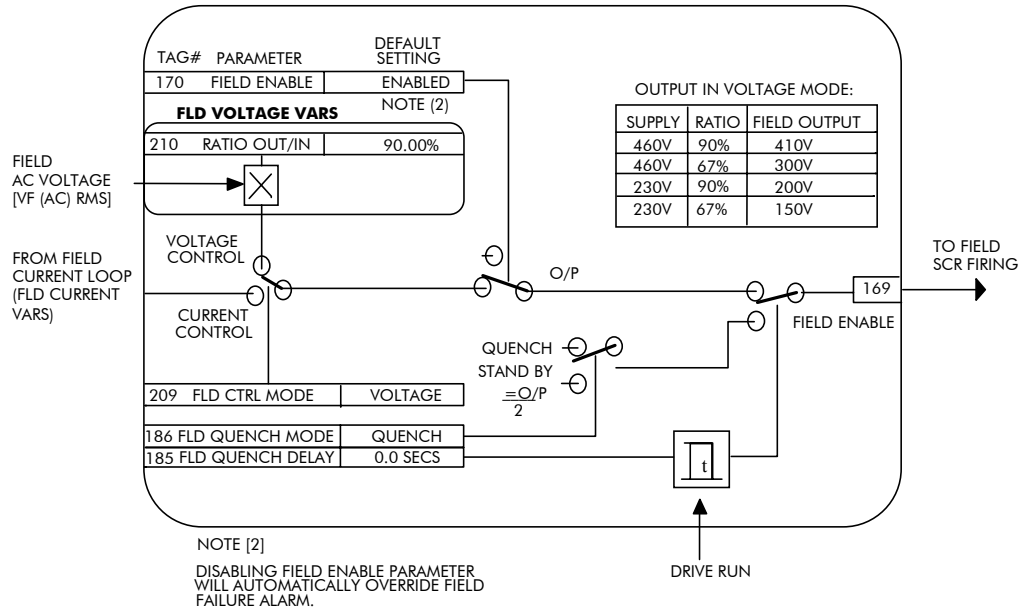

FLD CURRENT VARS

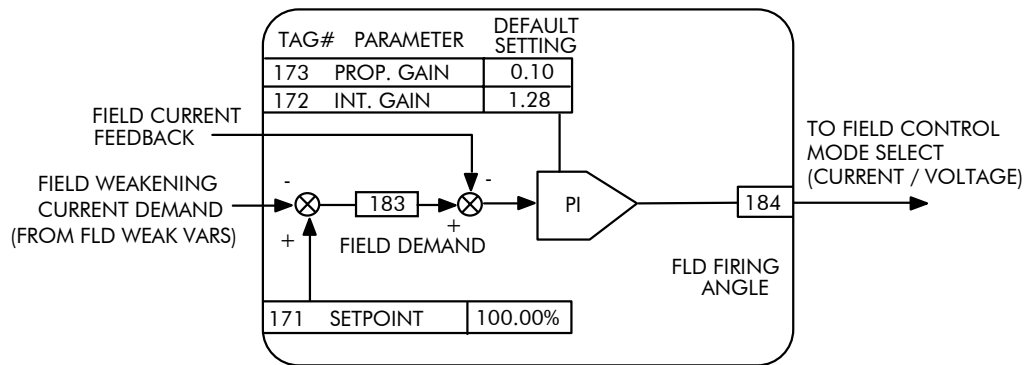

FLD WEAK VARS

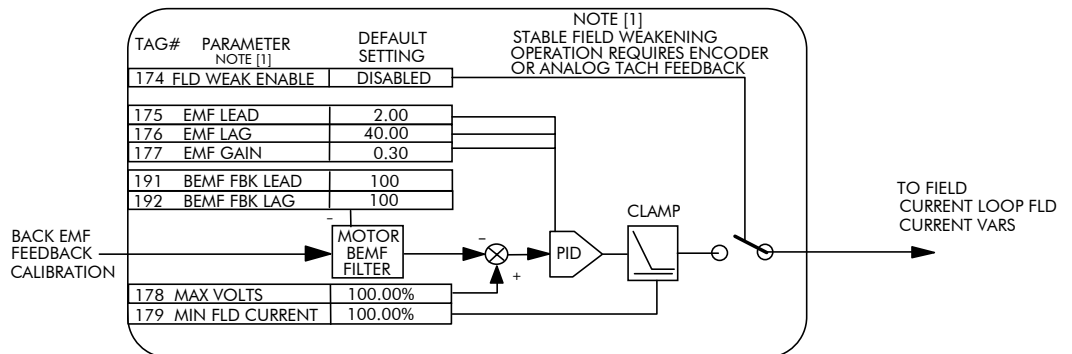

ALARMS

This function block is contained in three menus on the MMI. It provides a view into the current and past trip conditions, and allows some trips to be disabled.

MMI Menu Map

- 1 SETUP PARAMETERS
- 2 INHIBIT ALARMS
 - FIELD FAIL
 - 5703 RCV ERROR
 - STALL TRIP
 - TRIP RESET
 - SPEED FBK ALARM
 - ENCODER ALARM
 - REM TRIP INHIBIT

MMI Menu Map

- 1 ALARM STATUS
 - LAST ALARM
 - HEALTH WORD
 - HEALTH STORE
 - THERMISTOR STATE
 - SPEED FBK STATE
 - STALL TRIP
 - REMOTE TRIP

MMI Menu Map

- 1 SETUP PARAMETERS
- 2 CALIBRATION
 - REM TRIP DELAY

Alarms		
	READY [125]	FALSE
	HEALTHY [122]	TRUE
	HEALTH WORD [115]	0x0000
	HEALTH STORE [116]	0x0000
	REMOTE TRIP [542]	FALSE
	STALL TRIP [112]	OK
	LAST ALARM [528]	NO ACTIVE ALARMS
ENABLED	[19] FIELD FAIL	
ENABLED	[111] 5703 RCV ERROR	
INHIBITED	[28] STALL TRIP INHIBIT	
TRUE	[305] TRIP RESET	
ENABLED	[81] SPEED FBK ALARM	
ENABLED	[92] ENCODER ALARM	
ENABLED	[540] REM TRIP INHIBIT	
10.0 SECS	[541] REM TRIP DELAY	

Parameter Descriptions

READY

Range: See below

Refer to the *DIAGNOSTICS* function block description, page 6-22.

- 0 : FALSE
- 1 : TRUE

HEALTHY

Range: See below

(HEALTH LED)

Refer to the *DIAGNOSTICS* function block description, page 6-22.

- 0 : FALSE
- 1 : TRUE

HEALTH WORD

Range: 0x0000 to 0xFFFF

The hexadecimal sum of any alarms present. Refer to Chapter 7: “Trips and Fault Finding” - Alarm Messages.

HEALTH STORE

Range: 0x0000 to 0xFFFF

The hexadecimal value of the first (or only) alarm. Refer to Chapter 7: “Trips and Fault Finding” - Alarm Messages.

REMOTE TRIP

Range: See below

The state of Remote Trip.

- 0 : FALSE
- 1 : TRUE

STALL TRIP

Range: See below

Armature current is above STALL THRESHOLD and AT ZERO SPEED but not AT ZERO SETPOINT.

- 0 : OK
- 1 : FAILED

6-36 Programming Your Application

LAST ALARM

Range: See below

The hexadecimal value of the last (or only) alarm. Refer to Chapter 7: "Trips and Fault Finding" - Alarm Messages.

0x0000 : NO ACTIVE ALARMS
0x0001 : OVER SPEED
0x0002 : MISSING PULSE
0x0004 : FIELD OVER I
0x0008 : HEATSINK TRIP
0x0010 : THERMISTOR
0x0020 : OVER VOLTS (VA)
0x0040 : SPD FEEDBACK
0x0080 : ENCODER FAILED
0x0100 : FIELD FAILED
0x0200 : 3 PHASE FAILED
0x0400 : PHASE LOCK
0x0800 : 5703 RCV ERROR
0x1000 : STALL TRIP
0x2000 : OVER I TRIP
0xf005 : EXTERNAL TRIP
0x8000 : ACCTS FAILED
0xf001 : AUTOTUNE ERROR
0xf002 : AUTOTUNE ABORTED
0xf200 : CONFIG ENABLED
0xf400 : NO OP-STATION
0xf006 : REMOTE TRIP
0xff05 : PCB VERSION
0xff06 : PRODUCT CODE

FIELD FAIL

Range: See below

Inhibits the field fail alarm.

0 : ENABLED
1 : INHIBITED

5703 RCV ERROR

Range: See below

Inhibits 5703 serial communications receive error. Only active in Slave Mode.

0 : ENABLED
1 : INHIBITED

STALL TRIP INHIBIT

Range: See below

(STALL TRIP)

Inhibits the stall trip alarm from tripping the contactor out.

0 : ENABLED
1 : INHIBITED

TRIP RESET

Range: See below

When this is FALSE the faults are latched permanently and the HEALTHY output remains inactive after toggling the Start input (C3) off/on. The Trip Reset must then be set to TRUE for the faults to be reset and the HEALTHY output to go active (high) when C3 goes low. This feature can be used in applications where you want to reset the faults under your own control, rather than automatically with the Start/Run command.

0 : FALSE
1 : TRUE

SPEED FBK ALARM

Range: See below

Inhibits the speed feedback alarm.

0 : ENABLED
1 : INHIBITED

ENCODER ALARM

Range: See below

Inhibits the encoder option board alarm.

0 : ENABLED
1 : INHIBITED

REM TRIP INHIBIT

Range: See below

Inhibits the remote trip

0 : ENABLED
1 : INHIBITED

REM TRIP DELAY

Range: 0.1 to 600.0 SECS

The delay between the remote trip alarm being activated and the drive tripping.

Functional Description

INHIBIT ALARMS

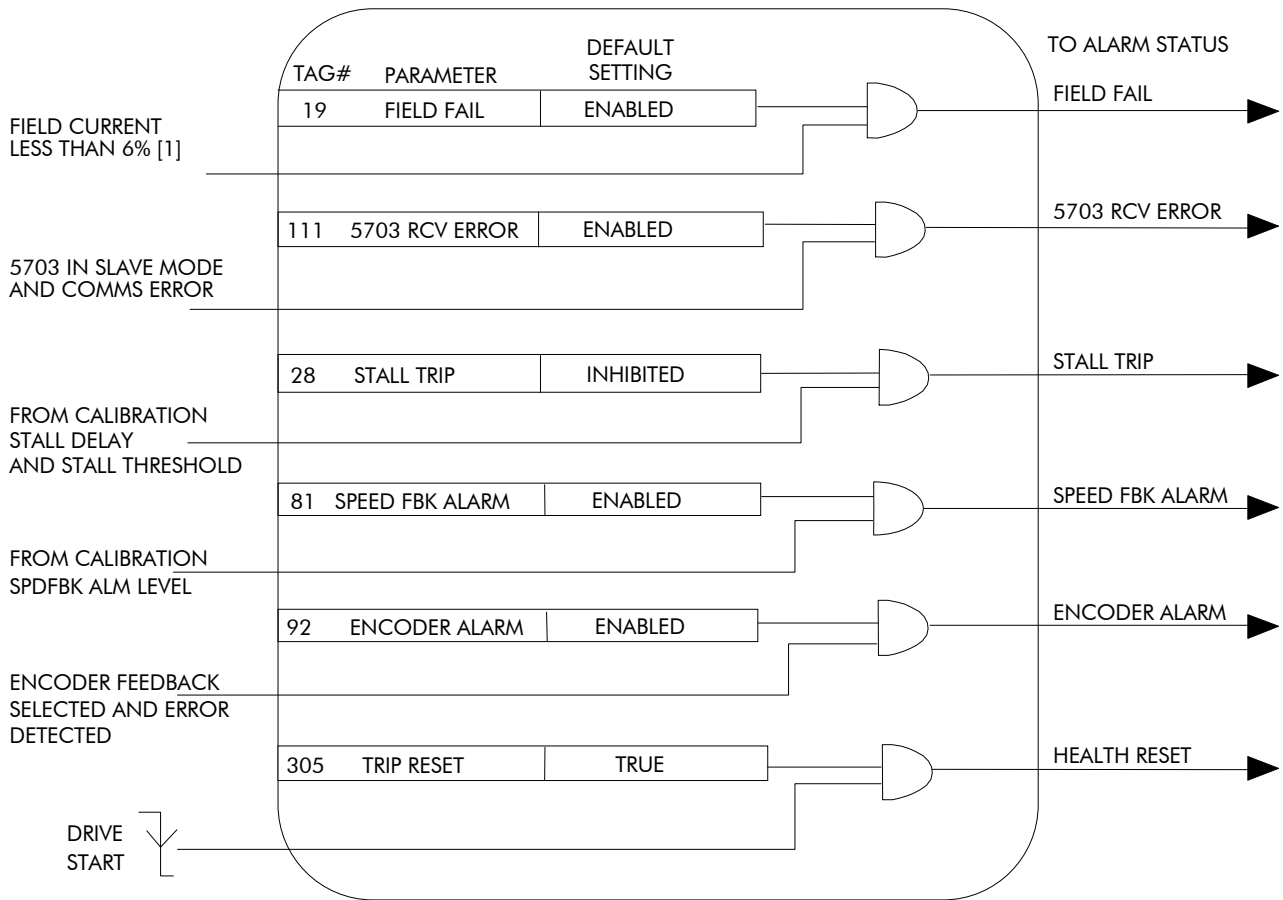

NOTE [1]:

FIELD FAIL THRESHOLD IS 6% IN CURRENT CONTROL
12% IN VOLTAGE CONTROL

6-38 Programming Your Application

MMI Menu Map

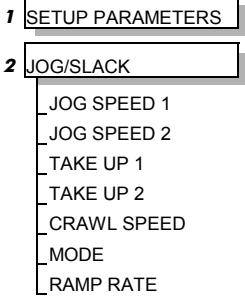

JOG/SLACK

This block holds all the parameters that concern the Jog functionality on the converter.

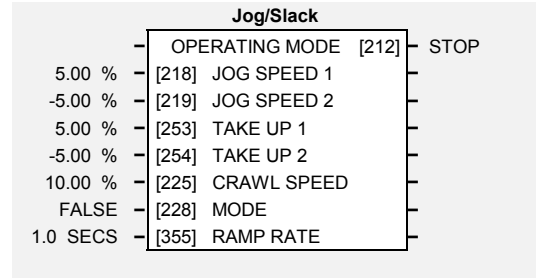

Parameter Descriptions

OPERATING MODE

Range: See below

Refer to the DIAGNOSTICS function block description, page 6-22.

- 0 : STOP
- 1 : STOP
- 2 : JOG SP. 1
- 3 : JOG SP. 2
- 4 : RUN
- 5 : TAKE UP SP. 1
- 6 : TAKE UP SP. 2
- 7 : CRAWL

JOG SPEED 1

Range: -100.00 to 100.00 %

Jog speed 1 setpoint.

JOG SPEED 2

Range: -100.00 to 100.00 %

Jog speed 2 setpoint.

TAKE UP 1

Range: -100.00 to 100.00 %

Take-up slack speed setpoint 1.

TAKE UP 2

Range: -100.00 to 100.00 %

Take-up slack speed setpoint 2.

CRAWL SPEED

Range: -100.00 to 100.00 %

Crawl speed setpoint.

MODE

Range: See below

Jog/Slack operating mode select. To use the full block functionality, MODE must be connected to a digital input.

- 0 : FALSE
- 1 : TRUE

RAMP RATE

Range: 0.1 to 600.0 SECS

The ramp rate used while jogging is independent of the main ramp rate during normal running. The acceleration and deceleration times in jog are always equal.

Functional Description

To fully make use of all the modes of operation the MODE select input (Tag No. 228) must be connected to a free digital input.

Note: The setpoint column in the table below refers to the Ramp Input ONLY as indicated in the relevant column of the table. Any direct setpoints present will also add to this setpoint to make the total speed setpoint. If this is not desirable, as for example during jogging, then the direct setpoints should be disconnected during the appropriate conditions.

Operating Mode	Mode Tag No 228	Start C3	Jog C4	Ramp Input	Ramp Time	Contactor
Stop	False	OFF	OFF	Setpoint	Default	OFF
Stop	True	OFF	OFF	Setpoint	Default	OFF
Run	False	ON	OFF	Setpoint	Default	ON
Take-Up Slack 1	False	ON	ON	Setpoint + Take-Up Slack 1	Default	ON
Take-Up Slack 2	True	ON	OFF	Setpoint + Take-Up Slack 2	Default	ON
Inch / Jog 1	False	OFF	ON	Jog Speed 1	Jog Ramp Rate	ON
Inch / Jog 2	True	OFF	ON	Jog Speed 2	Jog Ramp Rate	ON
Crawl	True	ON	ON	Crawl Speed	Default	ON

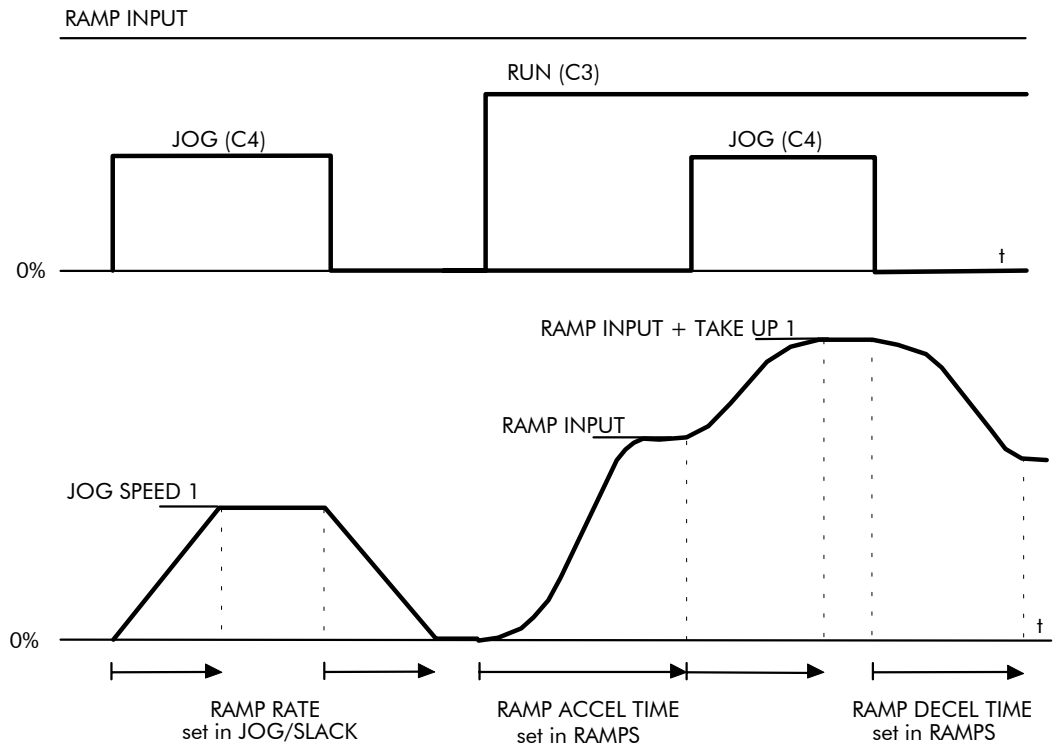

Block Diagram

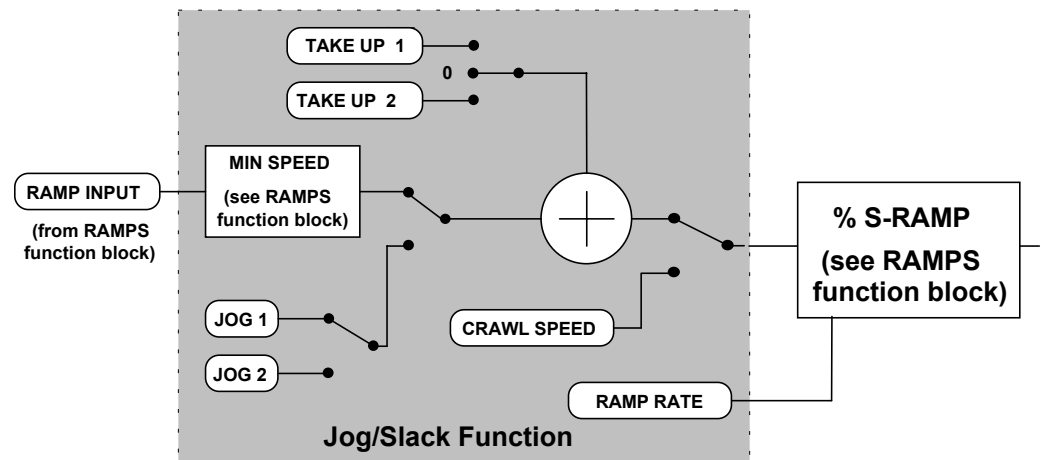

LINK 11 & LINK 12

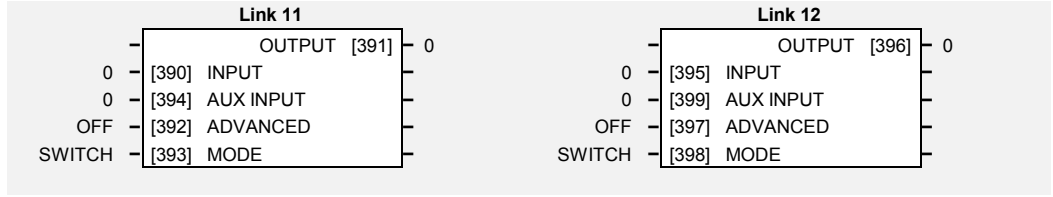
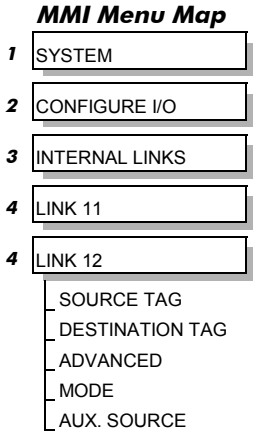

Links 11 and 12 allow further functionality within the block diagram. The following diagram shows the internal schematic for an advanced link.

Parameter Descriptions

OUTPUT

Range: 0 to 549

(DESTINATION TAG)

Selects the tag to where the output will be written. Refer to “Special Links”, page 6-1.

INPUT

Range: 0 to 549

(SOURCE TAG)

Selects the source tag for the primary input. Refer to “Special Links”, page 6-1.

AUX INPUT

Range: 0 to 549

(AUX.SOURCE)

Provides the second input for the two-input functions of the MODE selection. Refer to “Special Links”, page 6-1.

ADVANCED

Range: See below

When OFF it makes the extended link appear as a standard link, i.e. it copies INPUT to OUTPUT. When ON it extends the link’s functionality according to the MODE selected (see below).

- 0 : OFF
- 1 : ON

MODE

Range: See below

This determines which operation is performed on the INPUT (and sometimes also the AUX INPUT) before copying the result into the OUTPUT. It can be combined with ADVANCED to dynamically **switch** the OUTPUT between two inputs (INPUT and AUX INPUT). The functionality of the various MODE selections are shown in the table.

- 0 : SWITCH
- 1 : INVERTER
- 2 : AND
- 3 : OR
- 4 : SIGN CHANGER
- 5 : MODULUS
- 6 : COMPARATOR

Functional Description

Link 11 & Link 12

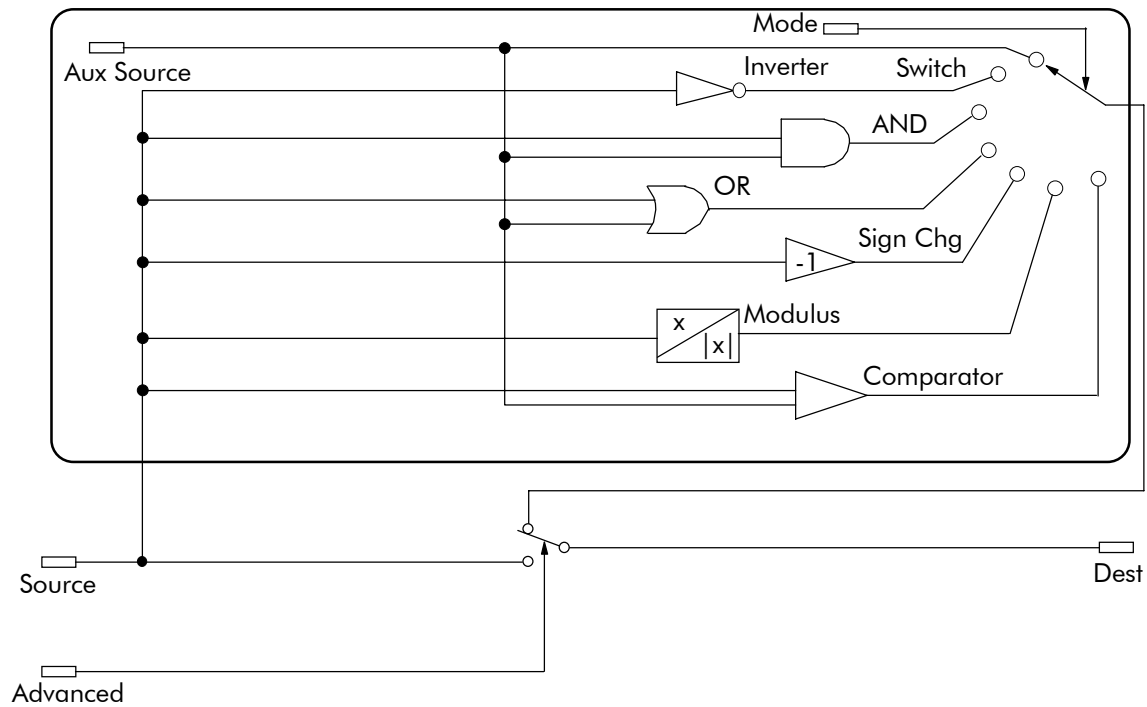

Mode	Description
SWITCH	If ADVANCED = OFF DESTINATION = SOURCE If ADVANCED = ON DESTINATION = AUX SOURCE
INVERTER	If ADVANCED = OFF DESTINATION = SOURCE If ADVANCED = ON DESTINATION = Logic Inversion of SOURCE
AND	If ADVANCED = OFF DESTINATION = SOURCE If ADVANCED = ON DESTINATION = SOURCE AND AUX SOURCE
OR	If ADVANCED = OFF DESTINATION = SOURCE If ADVANCED = ON DESTINATION = SOURCE OR AUX SOURCE
SIGN CHANGER	If ADVANCED = OFF DESTINATION = SOURCE If ADVANCED = ON DESTINATION = Value sign change of SOURCE
MODULUS	If ADVANCED = OFF DESTINATION = SOURCE If ADVANCED = ON DESTINATION = Modulus of SOURCE
COMPARATOR	If ADVANCED = OFF DESTINATION = SOURCE If ADVANCED = ON If SOURCE < AUX SOURCE DESTINATION = 0 If ADVANCED = ON If SOURCE > AUX SOURCE DESTINATION = 1

MENUS

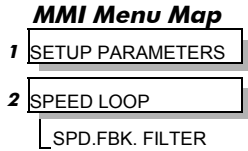
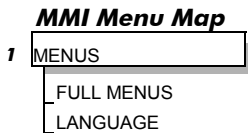

This function block allows selection of either the full menu structure, or a reduced menu structure for easier navigation of the menu. It also selects the display language for the MMI.

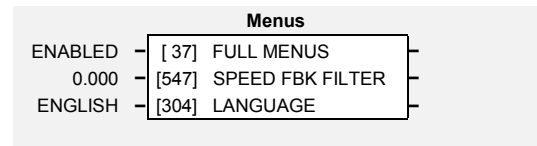

Parameter Descriptions

FULL MENU

Range: See below

When enabled, the full MMI menu structure is displayed on the MMI.

- 0 : DISABLED
- 1 : ENABLED

SPEED FBK FILTER

Range: 0.000 to 1.000

(SPD.FBK.FILTER)

A simple filter function that is applied to speed feedback to reduce ripple caused by low line count encoders. A value of 0 disables the filter action, and 1.00 is the maximum value. A typical value would be between 0.5 and 0.75.

INCREASING THE FILTER VALUE MAY MAKE THE SPEED LOOP UNSTABLE.

The filter time constant τ in milliseconds can be calculated from the following equation:

$$\tau = \frac{3.3}{\text{Log}_e\left(\frac{1}{\alpha}\right)}$$

Where α is the value of SPD FBK FILTER. A value of 0.5 equates to a filter time of 4.8ms, 0.8 to 14.7ms, and 0.9 to 31.2ms.

LANGUAGE

Range: See below

Selects the MMI display language. Other languages are available, please contact Eurotherm Drives. Refer also to Chapter 5: "The Operator Station" - Selecting the Display Language.

- 0 : ENGLISH
- 1 : Other

miniLINK

This function block is no longer supported.

MMI Menu Map

1	SYSTEM
2	miniLINK
	VALUE 1
	VALUE 2
	VALUE 3
	VALUE 4
	VALUE 5
	VALUE 6
	VALUE 7
	VALUE 8
	VALUE 9
	VALUE 10
	VALUE 11
	VALUE 12
	VALUE 13
	VALUE 14
	LOGIC 1
	LOGIC 2
	LOGIC 3
	LOGIC 4
	LOGIC 5
	LOGIC 6
	LOGIC 7
	LOGIC 8

miniLINK	
0.00 %	[339] VALUE 1
0.00 %	[340] VALUE 2
0.00 %	[341] VALUE 3
0.00 %	[342] VALUE 4
0.00 %	[343] VALUE 5
0.00 %	[344] VALUE 6
0.00 %	[345] VALUE 7
0.00 %	[379] VALUE 8
0.00 %	[380] VALUE 9
0.00 %	[381] VALUE 10
0.00 %	[382] VALUE 11
0.00 %	[383] VALUE 12
0.00 %	[384] VALUE 13
0.00 %	[385] VALUE 14
OFF	[346] LOGIC 1
OFF	[347] LOGIC 2
OFF	[348] LOGIC 3
OFF	[349] LOGIC 4
OFF	[350] LOGIC 5
OFF	[351] LOGIC 6
OFF	[352] LOGIC 7
OFF	[353] LOGIC 8

Parameter Descriptions

VALUE 1 to VALUE 14

Range: -300.00% to 300.00%

LOGIC 1 to LOGIC 8

Range: See below

0 : OFF
1 : ON

OP STATION

This function block is viewed in three separate menus on the MMI: SET UP, START UP VALUES and LOCAL RAMP.

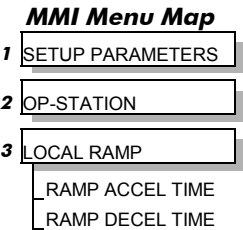
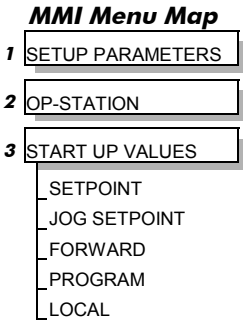
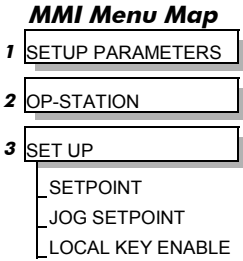
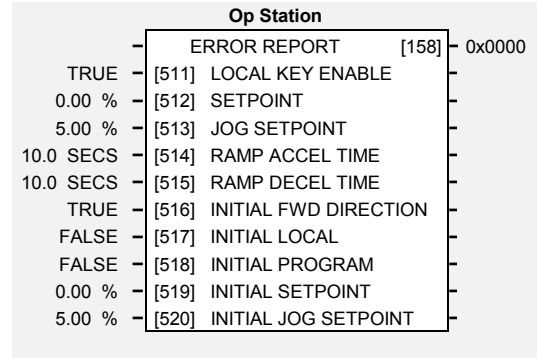

Parameter Descriptions

ERROR REPORT

(OP STATION ERROR)

Reserved parameter for use by Eurotherm Drives.

Range: 0x0000 to 0xFFFF

LOCAL KEY ENABLE

Enables the "local key" on the op-station, this must be set TRUE to allow the operator to toggle between local and remote modes.

Range: See below

- 0 : FALSE
- 1 : TRUE

SETPOINT

Actual value of local setpoint.

SET UP menu

Range: 0.00 to 100.00 %

JOG SETPOINT

Actual value of local jog setpoint.

SET UP menu

Range: 0.00 to 100.00 %

RAMP ACCEL TIME

Acceleration time used while in Local mode.

Range: 0.1 to 600.0 SECS

RAMP DECEL TIME

Deceleration time used while in Local mode.

Range: 0.1 to 600.0 SECS

INITIAL FWD DIRECTION

(FORWARD)

Start-up mode of local direction on power-up. Set to TRUE for Forward.

Range: See below

- 0 : FALSE
- 1 : TRUE

INITIAL LOCAL

(LOCAL)

Start-up mode of Operator Station L/R key on power-up. Set to TRUE for Local mode.

Range: See below

- 0 : FALSE
- 1 : TRUE

INITIAL PROGRAM

(PROGRAM)

Start-up mode of Operator Station PROG key on power-up. Set to TRUE for Program mode, to see the local setpoint.

Range: See below

- 0 : FALSE
- 1 : TRUE

INITIAL SETPOINT

(SETPOINT)

Default value of local setpoint on power-up.

START UP VALUES menu

Range: 0.00 to 100.00 %

INITIAL JOG SETPOINT

(JOG SETPOINT)

Default Value of local jog setpoint on power up.

START UP VALUES menu

Range: 0.00 to 100.00 %

Functional Description

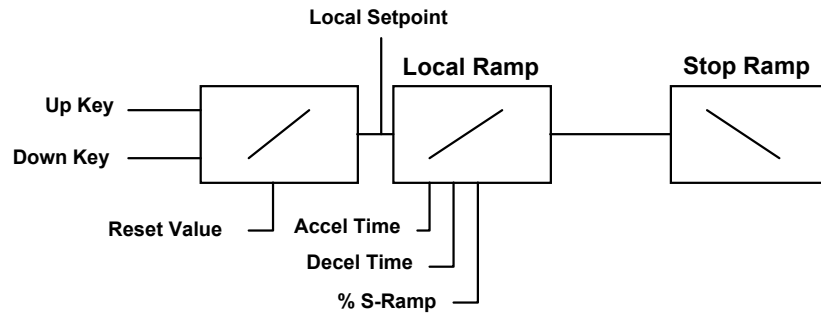
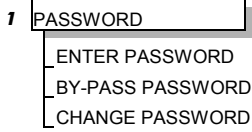

Figure 5. 2 Local Setpoint (only active when the drive is in Local mode)

6-46 Programming Your Application

MMI Menu Map



PASSWORD (MMI only)

Use this MMI menu to activate or deactivate the password protection feature. Refer to Chapter 5: “The Operator Station” - Password Protection for further instruction.

Parameter Descriptions

ENTER PASSWORD *Tag 120* *Range: 0x0000 to 0xFFFF*
Default = 0x0000.

BY-PASS PASSWORD *Tag 526* *Range: See below*
Default = FALSE
Reserved parameter for use by Eurotherm Drives.

0 : FALSE
1 : TRUE

CHANGE PASSWORD *Tag 121* *Range: 0x0000 to 0xFFFF*
Default = 0x0000.

MMI Menu Map

- 1 **SETUP PARAMETERS**
- 2 **SPECIAL BLOCKS**
- 3 **PID**
 - PROP. GAIN
 - SPD.INT.TIME
 - DERIVATIVE TC
 - POSITIVE LIMIT
 - NEGATIVE LIMIT
 - O/P SCALER(TRIM)
 - INPUT 1
 - INPUT 2
 - RATIO 1
 - RATIO 2
 - DIVIDER 1
 - DIVIDER 2
 - ENABLE
 - INT. DEFEAT
 - FILTER T.C.
 - MODE
 - MIN PROFILE GAIN
 - PROFILED GAIN

PID

This is a general purpose PID block which can be used for many different closed loop control applications. The PID feedback can be loadcell tension, dancer position or any other transducer feedback such as pressure, flow etc.

Features:

- Independent adjustment of gain and time constants.
- Additional first-order filter (F).
- Functions P, PI, PD, PID with/without F individually selected.
- Ratio and divider for scaling each input.
- Independent positive and negative limits.
- Output scaler (Trim).
- Gain profiled by diameter for centre-driven winder control.

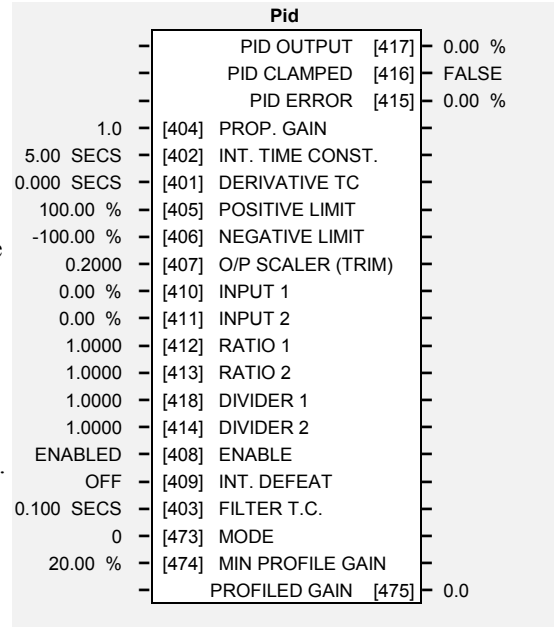

Parameter Descriptions

PID OUTPUT *Range: xxx.xx %*

Refer to the DIAGNOSTICS function block description, page 6-22.

PID CLAMPED *Range: See below*

Refer to the DIAGNOSTICS function block description, page 6-22.

0 : FALSE
1 : TRUE

PID ERROR *Range: xxx.xx %*

Refer to the DIAGNOSTICS function block description, page 6-22.

PROP. GAIN *Range: 0.0 to 100.0*

This is a pure gain factor which shifts up or down the whole Bode PID transfer function leaving the time constants unaffected. A value of P = 10.0 means that, for an error of 5%, the proportional part (initial step) of the PID output will be:

$$10 \times [1 + (T_d/T_i)] \times 5 \% , \quad \text{i.e. approx. 50\% for } T_d \ll T_i.$$

INT. TIME CONST. *Range: 0.01 to 100.00 SECS*

(SPD.INT.TIME)

The integrator time constant (Ti)

DERIVATIVE TC *Range: 0.000 to 10.000 SECS*

The differentiator time constant (Td). When Td = 0 the transfer function of the block becomes a P+I.

POSITIVE LIMIT *Range: 0.00 to 105.00 %*

The upper limit of the PID algorithm.

NEGATIVE LIMIT *Range: -105.00 to 0.00 %*

The lower limit of the PID algorithm.

O/P SCALER (TRIM) *Range: -3.0000 to 3.0000*
(O/P SCALER(TRIM))
The ratio which the limited PID output is multiplied by in order to give the final PID Output. Normally this ratio would be between 0 and 1.

INPUT 1 *Range: -300.00 to 300.00 %*
This can be either a position/tension feedback or a reference/offset.

INPUT 2 *Range: -300.00 to 300.00 %*
This can be either a position/tension feedback or a reference/offset

RATIO 1 *Range: -3.0000 to 3.0000*
This multiplies Input 1 by a factor (Ratio 1).

RATIO 2 *Range: -3.0000 to 3.0000*
This multiplies Input 2 by a factor (Ratio 2).

DIVIDER 1 *Range: -3.0000 to 3.0000*
This divides Input 1 by a factor (Divider 1).

DIVIDER 2 *Range: -3.0000 to 3.0000*
This divides Input 2 by a factor (Divider 2).

ENABLE *Range: See below*
A digital input which resets the (total) PID Output as well as the integral term when FALSE.
0 : DISABLED
1 : ENABLED

INT. DEFEAT *Range: See below*
A digital input which resets the integral term when TRUE. The block transfer function then becomes P+D only.
0 : OFF
1 : ON

FILTER T.C. *Range: 0.000 to 10.000 SECS*
In order to attenuate high-frequency noise a first order filter is added in conjunction with the differentiator. The ratio k of the Derivative Time Constant (Td) over the Filter Time Constant (Tf) (typically 4 or 5) determines the high-frequency lift of the transfer function. For Tf = 0 this filter is eliminated.

MODE *Range: 0 to 4*
This determines the law which the profiler follows versus diameter.
For Mode = 0, Profiled Gain = constant = P.
For Mode = 1, Profiled Gain = A * (diameter - min diameter) + B.
For Mode = 2, Profiled Gain = A * (diameter - min diameter)^2 + B.
For Mode = 3, Profiled Gain = A * (diameter - min diameter)^3 + B.
For Mode = 4, Profiled Gain = A * (diameter - min diameter)^4 + B.

MIN PROFILE GAIN *Range: 0.00 to 100.00 %*
This expresses the minimum gain required at min diameter (core) as a percentage of the (max) P gain at full diameter (100%).

PROFILED GAIN *Range: xxxx.x*
The output of a profiler block which varies the gain versus diameter. This is primarily to be used with Speed Profiled Winders for compensation against varying diameter and therefore inertia. When MODE is not ZERO (see above) this overrides the P gain above.

Functional Description

The following block diagram shows the internal structure of the PID block.

PID is used to control the response of any closed loop system. It is used specifically in system applications involving the control of drives to allow zero steady state error between Reference and Feedback, together with good transient performance.

Proportional Gain (PROP. GAIN)

This is used to adjust the basic response of the closed loop control system. It is defined as the portion of the loop gain fed back to make the complete control loop stable. The PID error is multiplied by the Proportional Gain to produce an output.

Integral (INT. TIME CONST.)

The Integral term is used to give zero steady state error between the setpoint and feedback values of the PID. If the integral is set to a small value, this will cause an underdamped or unstable control system.

Derivative (DERIVATIVE TC)

This is used to correct for certain types of control loop instability, and therefore improve response. It is sometimes used when heavy or large inertia rolls are being controlled. The derivative term has an associated filter to suppress high frequency signals.

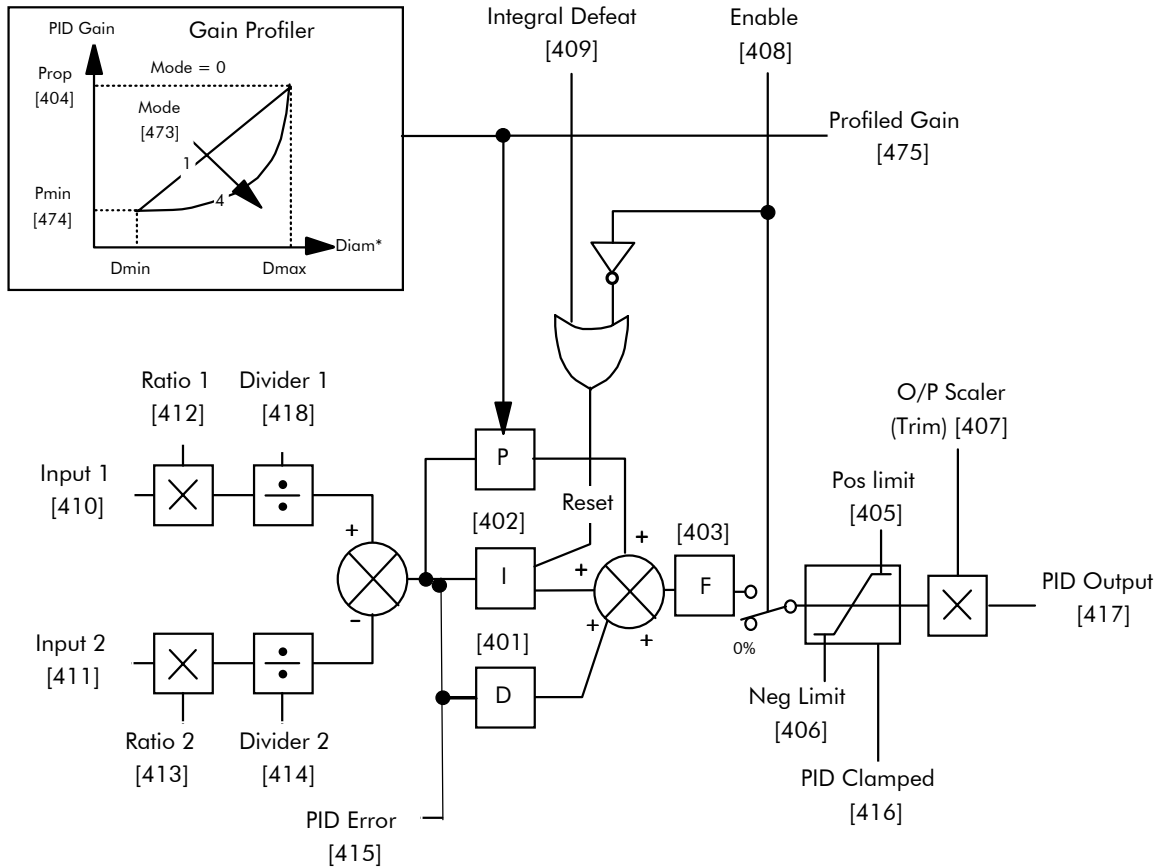

Critically Damped Response

You should achieve a critically damped response, which allows the mechanics to track as precisely as possible a step change on the setpoint.

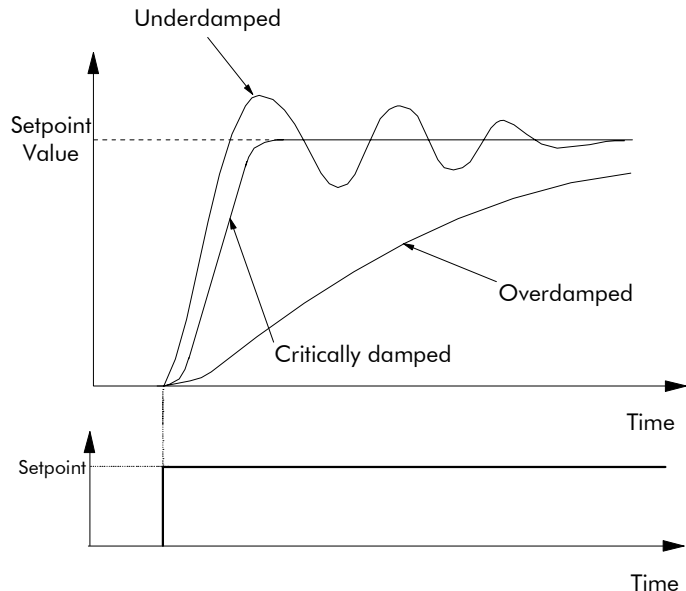

6-50 Programming Your Application

MMI Menu Map

- 1 SETUP PARAMETERS
- 2 RAISE/LOWER
 - RESET VALUE
 - INCREASE RATE
 - DECREASE RATE
 - RAISE INPUT
 - LOWER INPUT
 - MIN VALUE
 - MAX VALUE
 - EXTERNAL RESET

RAISE/LOWER

This function block acts as an internal motorised potentiometer (MOP).

The OUTPUT is not preserved during the power-down of the Converter.

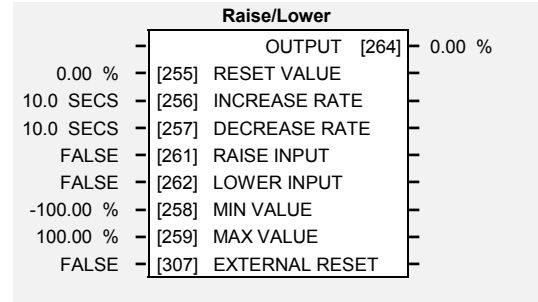

Parameter Descriptions

OUTPUT

Range: xxx.xx %

(RAISE/LOWER O/P)

Refer to the *DIAGNOSTICS* function block description, page 6-22..

RESET VALUE

Range: -300.00 to 300.00 %

This reset value is pre-loaded directly into the output when EXTERNAL RESET is TRUE, or at power-up. It will be clamped by min and max values.

INCREASE RATE

Range: 0.1 to 600.0 SECS

Rate of change of increasing output value.

DECREASE RATE

Range: 0.1 to 600.0 SECS

Rate of change of decreasing output value.

RAISE INPUT

Range: See below

Command to raise output.

- 0 : FALSE
- 1 : TRUE

LOWER INPUT

Range: See below

Command to lower output.

- 0 : FALSE
- 1 : TRUE

MIN VALUE

Range: -300.00 to 300.00 %

Minimum ramp output clamp. This is a plain clamp, not a ramped "min speed" setting.

MAX VALUE

Range: -300.00 to 300.00 %

Maximum ramp output clamp.

EXTERNAL RESET

Range: See below

If EXTERNAL RESET is TRUE, the output of the Raise/Lower block is set to the RESET VALUE.

- 0 : FALSE
- 1 : TRUE

Functional Description

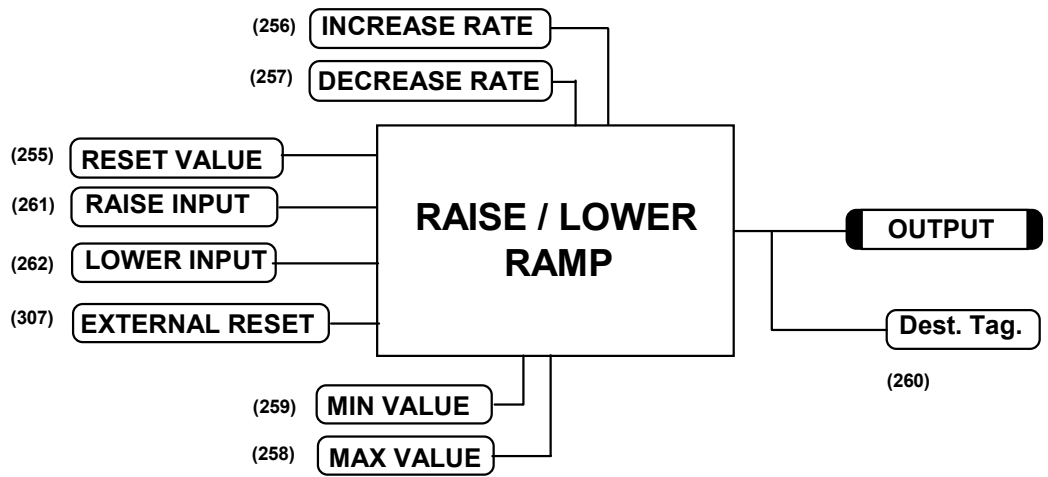
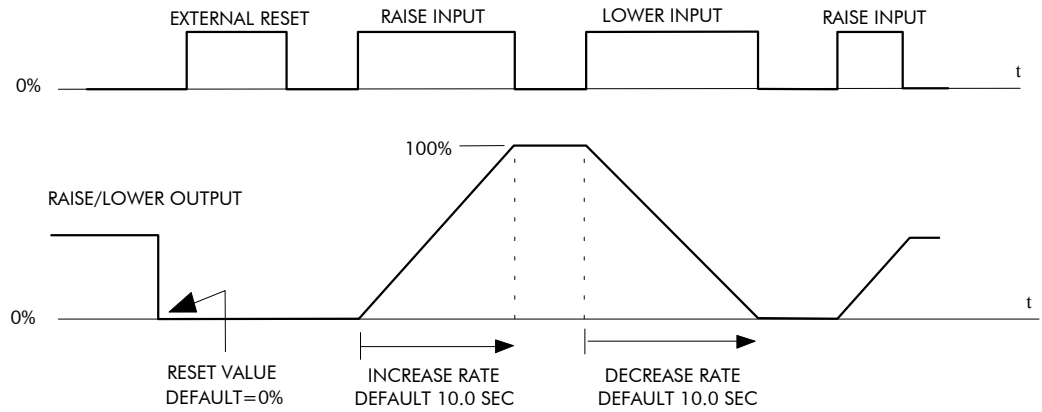

If Reset, Output = Reset Value (Clamped)

MMI Menu Map

1	SETUP PARAMETERS
2	RAMPS
	RAMP ACCEL TIME
	RAMP DECEL TIME
	CONSTANT ACCEL
	RAMP HOLD
	RAMP INPUT
	% S-RAMP
	RAMPING THRESH.
	AUTO RESET
	EXTERNAL RESET
	RESET VALUE
	MIN SPEED

RAMPS

This function block forms part of the reference generation. It provides the facility to control the rate at which the Converter will respond to a changing setpoint.

Ramps		
	RAMP OUTPUT [85]	0.00 %
	RAMPING [113]	FALSE
10.0 SECS	[2] RAMP ACCEL TIME	
10.0 SECS	[3] RAMP DECEL TIME	
ENABLED	[4] CONSTANT ACCEL	
OFF	[118] RAMP HOLD	
0.00 %	[5] RAMP INPUT	
2.50 %	[266] % S-RAMP	
0.50 %	[286] RAMPING THRESH.	
ENABLED	[287] AUTO RESET	
DISABLED	[288] EXTERNAL RESET	
0.00 %	[422] RESET VALUE	
0.00 %	[126] MIN. SPEED	

Parameter Descriptions

RAMP OUTPUT

Range: xxx.xx %

Refer to the *DIAGNOSTICS* function block description, page 6-22.

RAMPING

Range: See below

Refer to the *DIAGNOSTICS* function block description, page 6-22.

0 : FALSE
1 : TRUE

RAMP ACCEL TIME

Range: 0.1 to 600.0 SECS

Acceleration time (100% change)

RAMP DECEL TIME

Range: 0.1 to 600.0 SECS

Deceleration time (100% change)

CONSTANT ACCEL

Range: See below

Reserved parameter for use by Eurotherm Drives.

0 : DISABLED
1 : ENABLED

RAMP HOLD

Range: See below

While ON, the ramp output is held at its last value. This is overridden by *Ramp Reset*.

0 : OFF
1 : ON

RAMP INPUT

Range: -105.00 to 105.00 %

Ramp Input TAG.

% S-RAMP

Range: 0.00 to 100.00 %

Percentage of ramp with S-shaped rate of change. A value of zero is equivalent to a linear ramp. Changing this value affects the ramp times.

RAMPING THRESH.

Range: 0.00 to 100.00 %

Ramping flag threshold level. The threshold is used to detect whether the ramp is active.

AUTO RESET

Range: See below

If TRUE, then the ramp is reset whenever SYSTEM RESET is TRUE, that is each time the Speed/Current loop is unquenched. (SYSTEM RESET Tag No. 374 is an internal flag that is set TRUE for one cycle after the Speed/Current loop is enabled, i.e. every time the drive is started).

0 : DISABLED
1 : ENABLED

EXTERNAL RESET

Range: See below

If TRUE, then the ramp is held in reset. EXTERNAL RESET does not depend on AUTO RESET for its operation.

- 0 : DISABLED
- 1 : ENABLED

RESET VALUE

Range: -300.00 to 300.00 %

This value is pre-loaded into the output when RAMP RESET is TRUE, or at power-up. In order to catch a spinning load smoothly ('bumpless transfer') connect SPEED FEEDBACK Tag No. 62 (source) to RESET VALUE Tag No. 422 (destination).

MIN. SPEED

Range: 0.00 to 100.00 %

(MIN SPEED)

The minimum speed clamp is fully bi-directional and operates with a 0.5% hysteresis. This clamp operates on the input to the ramp and it can therefore be overridden by the RESET VALUE as far as the ramp output is concerned.

Minimum Speed

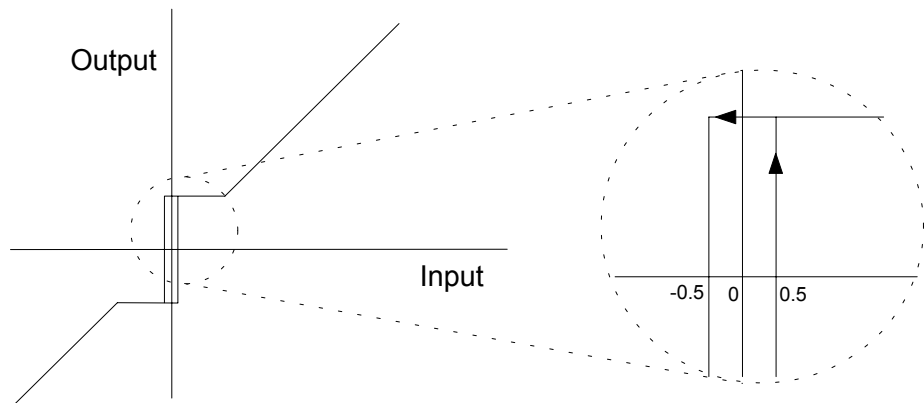

Functional Description

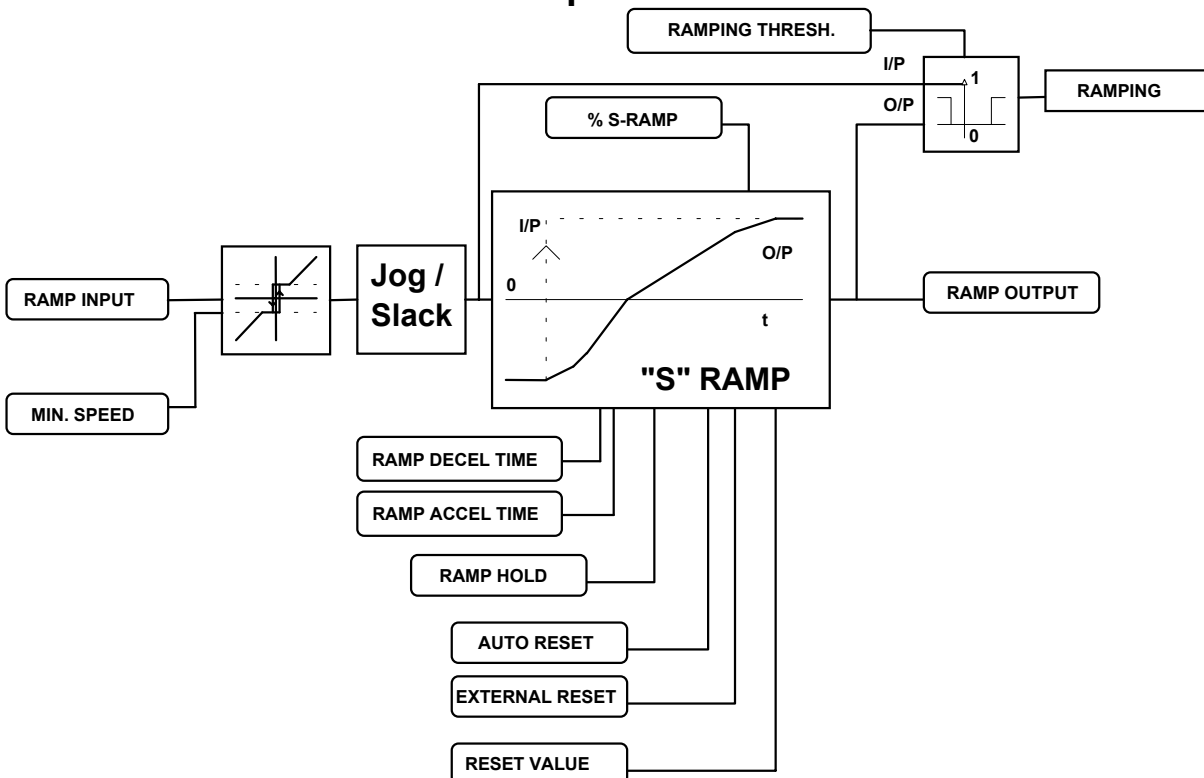

6-54 Programming Your Application

ACCELERATION/DECELERATION RATES

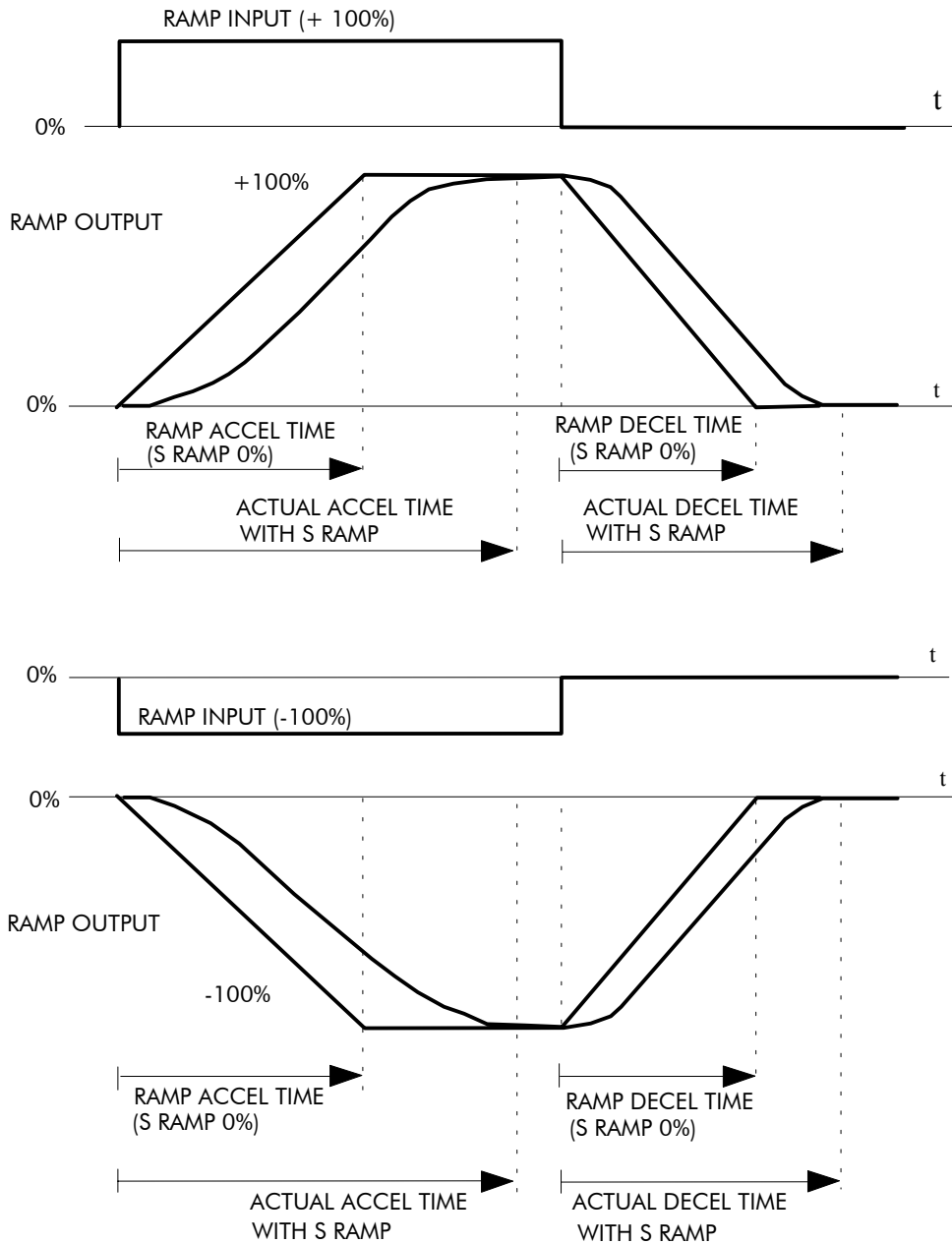

RAMP HOLD

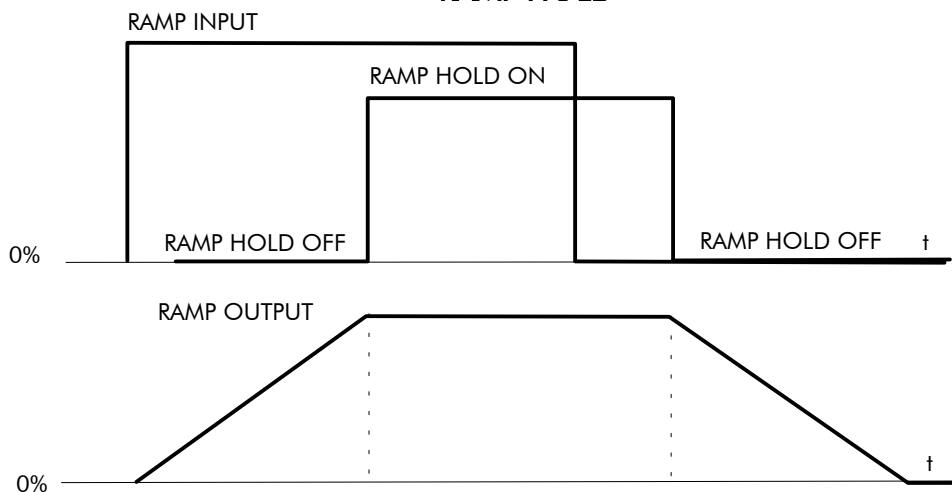

RAMP RESET

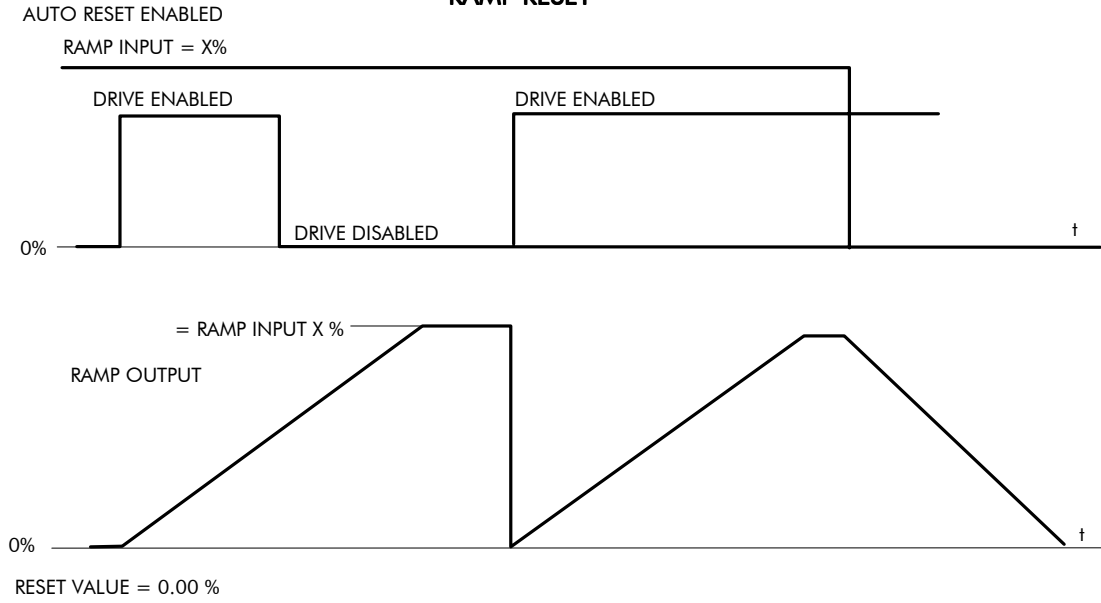

EXTERNAL RESET

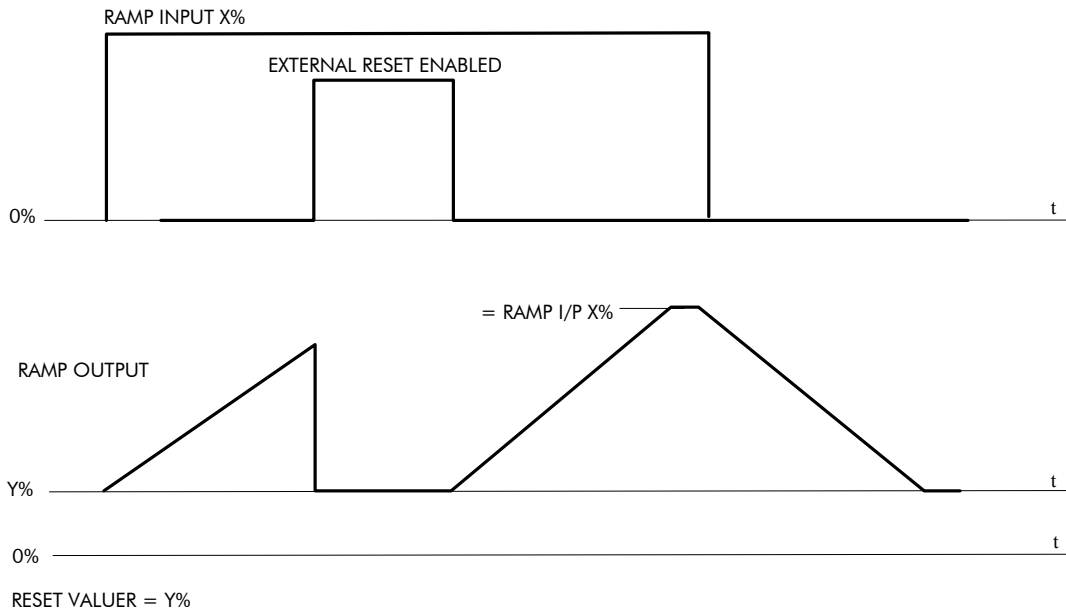

MIN SPEED

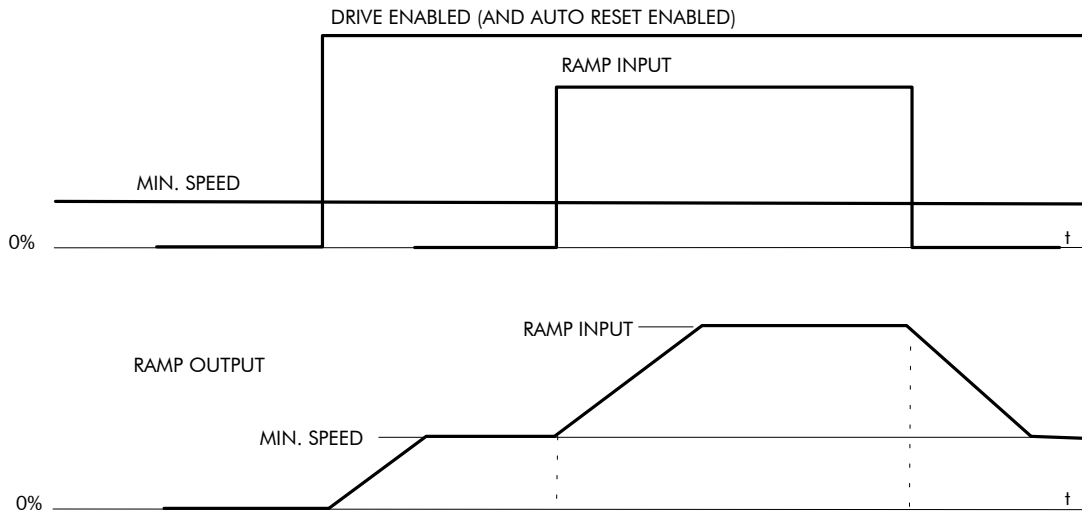

NOTE: THE POLARITY OF SPEED SETPOINT DETERMINES THE DIRECTION OF MIN. SPEED

MMI Menu Map

- 1 SETUP PARAMETERS
- 2 SETPOINT SUM 1
 - RATIO 1
 - RATIO 0
 - SIGN 1
 - SIGN 0
 - DIVIDER 1
 - DIVIDER 0
 - DEADBAND WIDTH
 - LIMIT
 - INPUT 2
 - INPUT 1
 - INPUT 0

SETPOINT SUM 1

This can be configured to perform one of a number of functions upon a fixed number of inputs.

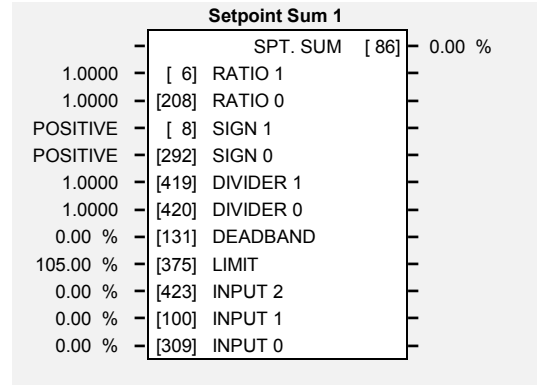

Parameter Descriptions

SPT. SUM

(SPT SUM OUTPUT)

Refer to the *DIAGNOSTICS* function block description, page 6-22.

Range: xxx.xx %

RATIO 1

Analog input 1 scaling.

Range: -3.0000 to 3.0000

RATIO 0

Input 0 scaling.

Range: -3.0000 to 3.0000

SIGN 1

Analog input 1 polarity.

Range: See below

- 0 : NEGATIVE
- 1 : POSITIVE

SIGN 0

Input 0 polarity.

Range: See below

- 0 : NEGATIVE
- 1 : POSITIVE

DIVIDER 1

Analog input 1 scaling. Dividing by 0 (zero) results in a zero output.

Range: -3.0000 to 3.0000

DIVIDER 0

Input 0 scaling. Dividing by 0 (zero) results in a zero output.

Range: -3.0000 to 3.0000

DEADBAND

(DEADBAND WIDTH)

Analog input 1 deadband width.

Range: 0.00 to 100.00 % (h)

LIMIT

The Setpoint Sum programmable limit is symmetrical and has the range 0.00% to 200.00%. The limit is applied both to the intermediate results of the RATIO calculation and the total output.

Range: 0.00 to 200.00 %

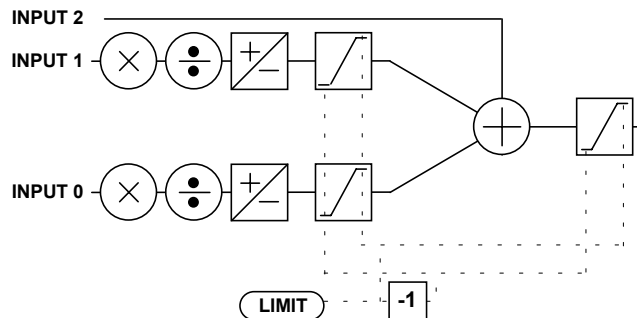

INPUT 2

Input 2 value. By default this is not connected to any analog input.

Range: -200.00 to 200.00 %

INPUT 1

Input 1 value. By default this is connected to Analog Input 1 (A2).

Range: -200.00 to 200.00 %

INPUT 0

Input 0 value. By default this is not connected to any analog input.

Range: -200.00 to 200.00 %

MMI Menu Map

- 1 **SETUP PARAMETERS**
- 2 **SPECIAL BLOCKS**
- 3 **SETPOINT SUM 2**
 - INPUT 2
 - INPUT 1
 - INPUT 0
 - RATIO 1
 - RATIO 0
 - DIVIDER 1
 - DIVIDER 0
 - LIMIT
 - SPT SUM OUTPUT
 - STPT SUM 2 OUT 0
 - STPT SUM 2 OUT 1

SETPOINT SUM 2

Setpoint Sum 2 is a general purpose summing and ratio block. Additional outputs are provided to gain access to each of Input 0 and Input 1 channel sub-calculations.

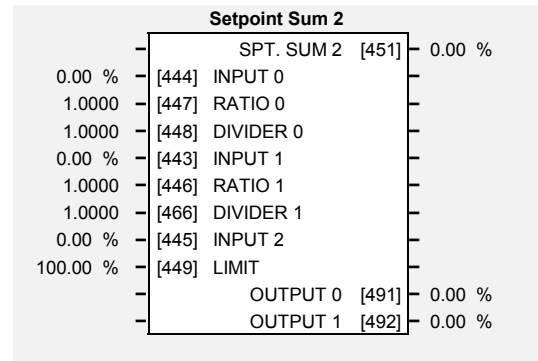

Parameter Descriptions

SPT. SUM 2

(SPT SUM OUTPUT)

Main output of Setpoint Sum 2.

This output is connected using the SYSTEM / CONFIGURE I/O / BLOCK DIAGRAM menu.

Range: xxx.xx %

INPUT 0

Input 0 value. By default this is not connected to any analog input.

Range: -300.00 to 300.00 %

RATIO 0

Input 0 scaling.

Range: -3.0000 to 3.0000

DIVIDER 0

Input 0 scaling. Dividing by 0 (zero) results in a zero output.

Range: -3.0000 to 3.0000

INPUT 1

Input 1 value. By default this is connected to analog input 1 (A2).

Range: -300.00 to 300.00 %

RATIO 1

Analog input 1 scaling.

Range: -3.0000 to 3.0000

DIVIDER 1

Analog input 1 scaling. Dividing by 0 (zero) results in a zero output.

Range: -3.0000 to 3.0000

INPUT 2

Input 2 value. By default this is not connected to any analog input.

Range: -300.00 to 300.00 %

LIMIT

The Setpoint Sum programmable limit is symmetrical and has the range 0.00% to 200.00%. The limit is applied both to the intermediate results of the RATIO calculation and the total output.

Range: 0.00 to 200.00 %

OUTPUT 0

(STPT SUM 2 OUT 0)

The result of (INPUT 0 x RATIO 0) / DIVIDER 0 clamped to within ± LIMIT.

Range: xxx.xx %

OUTPUT 1

(STPT SUM 2 OUT 1)

The result of (INPUT 1 x RATIO 1) / DIVIDER 1 clamped to within ± LIMIT.

Range: xxx.xx %

6-58 Programming Your Application

Functional Description

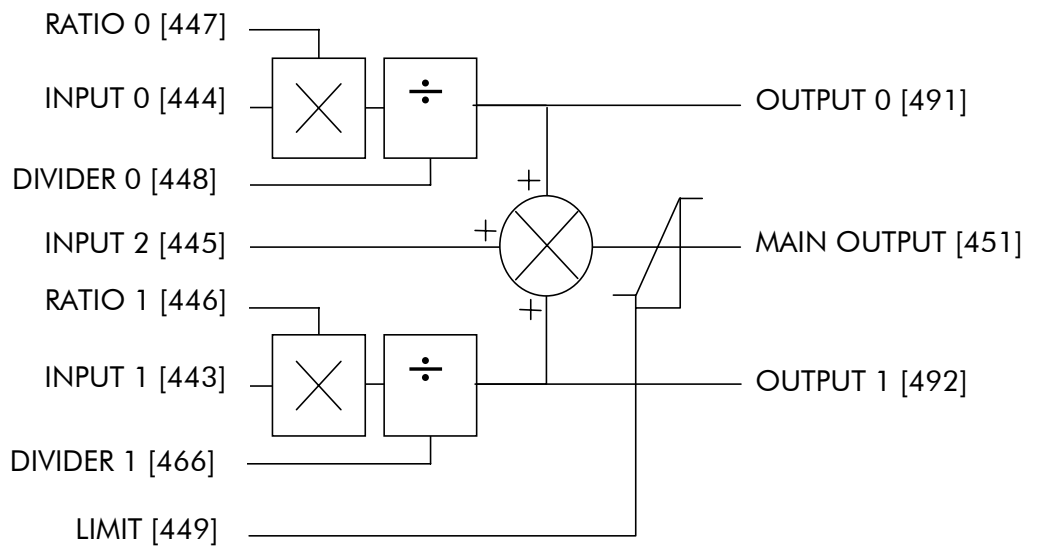

MMI Menu Map

- 1 SETUP PARAMETERS
- 2 SPEED LOOP
 - SPD.PROP.GAIN
 - SPD.INT.TIME
 - INT. DEFEAT
 - ENCODER SIGN
 - SPEED FBK SELECT
 - SPD.FBK.FILTER

MMI Menu Map

- 1 SETUP PARAMETERS
- 2 SPEED LOOP
- 3 SETPOINTS
 - SETPOINT 1
 - SIGN 2 (A3)
 - RATIO 2 (A3)
 - SETPOINT 2 (A3)
 - SETPOINT 3
 - SETPOINT 4
 - MAX DEMAND
 - MIN DEMAND

MMI Menu Map

- 1 CONFIGURE DRIVE
 - SPEED FBK SELECT
 - ENCODER SIGN
 - SPD. INT. TIME
 - SPD PROP GAIN

SPEED LOOP

This function block contains parameters for setting-up the speed loop. The block is viewed in two menus on the MMI.

SETPOINTS

This MMI menu contains the setpoint parameter reference inputs for the function block.

ADVANCED

Refer to page 6-63.

Speed Loop			
	OUTPUT	[356]	0.00 %
	SPEED FEEDBACK	[62]	0.00 %
	SPEED SETPOINT	[63]	0.00 %
	SPEED ERROR	[64]	0.00 %
10.00	[14] PROP. GAIN		
0.500 SECS	[13] INT. TIME CONST.		
OFF	[202] INT. DEFEAT		
POSITIVE	[49] ENCODER SIGN		
ARM VOLTS FBK	[47] SPEED FBK SEL		
0.00 %	[289] SETPOINT 1		
POSITIVE	[9] SIGN 2 (A3)		
1.0000	[7] RATIO 2 (A3)		
	SETPOINT 2 (A3)	[290]	0.00 %
0.00 %	[291] SETPOINT 3		
0.00 %	[41] SETPOINT 4		
105.00 %	[357] MAX DEMAND		
-105.00 %	[358] MIN DEMAND		

Parameter Descriptions

OUTPUT

Range: xxx.xx %

(SPD LOOP OUTPUT)

Refer to the *DIAGNOSTICS* function block description, page 6-22.

SPEED FEEDBACK

Range: xxx.xx %

(RAW SPEED FBK)

The speed feedback value from the source chosen by SPEED FBK SEL.

SPEED SETPOINT

Range: xxx.xx %

Refer to the *DIAGNOSTICS* function block description, page 6-22.

SPEED ERROR

Range: xxx.xx %

(RAW SPEED ERROR)

Refer to the *DIAGNOSTICS* function block description, page 6-22.

PROP. GAIN

Range: 0.00 to 200.00

(SPD.PROP.GAIN)

Speed loop PI proportional gain adjustment.

INT. TIME CONST.

Range: 0.001 to 30.000 SECS

(SPD.INT.TIME)

Speed loop PI integral gain adjustment.

6-60 Programming Your Application

INT. DEFEAT

Range: See below

Inhibits the integral part of the speed loop PI control to give proportional only control.

- 0 : OFF
- 1 : ON

ENCODER SIGN

Range: See below

Since the encoder feedback cannot be reversed electrically, the signal polarity can be reversed by the control software.

- 0 : NEGATIVE
- 1 : POSITIVE

SPEED FBK SEL

Range: See below

(SPEED FBK SELECT)

Four options are available:

- 0 : ARM VOLTS FBK
- 1 : ANALOG TACH
- 2 : ENCODER
- 3 : ENCODER/ANALOG

SETPOINT 1

Range: -105.00 to 105.00 %

Speed Setpoint 1 (Default Setpoint Sum 1 O/P).

SIGN 2 (A3)

Range: See below

Speed Setpoint 2 Sign.

- 0 : NEGATIVE
- 1 : POSITIVE

RATIO 2 (A3)

Range: -3.0000 to 3.0000

Speed Setpoint 2 Ratio.

SETPOINT 2 (A3)

Range: xxx.xx %

Speed Setpoint 2 - Fixed (non-configurable) setpoint scanned synchronously with the current loop

SETPOINT 3

Range: -105.00 to 105.00 %

Speed Setpoint 3 (Default Ramp O/P).

SETPOINT 4

Range: -105.00 to 105.00 %

Speed Setpoint 4 (Default 5703 I/P).

MAX DEMAND

Range: 0.00 to 105.00 %

Sets the maximum input to the speed loop. It is clamped at 105% to allow for overshoot in the external loops.

MIN DEMAND

Range: -105.00 to 105.00 %

Sets the minimum input to the speed loop.

Functional Description

Speed Loop PI Output

The PI output is accessible via Tag No. 356. This point is before the I Limit clamps and the summing of the additional current demand.

This Tag is not visible on the MMI.

Speed Loop PI with Current Demand Isolate

The speed loop output is still valid (active) with the I DMD. ISOLATE parameter enabled.

- Note:**
- 1 The speed loop is reset by unquenching the speed loop/current loop.
 - 2 I DMD. ISOLATE is overridden by Program Stop (B8) or Normal Stop (C3).
 - 3 The speed loop PI is holding the integral term as soon as the PI output reaches current limit. This is true even in Current Demand Isolate mode where it may interfere depending on the way the speed PI is used. This feature is currently not suppressible.

105% Speed Demands

The speed demand clamping allows the speed setpoint to reach 105%. This applies only to the final summing junction immediately before the speed loop and also to the Setpoint Sum 1 output. Individual speed setpoints are still clamped to 100%.

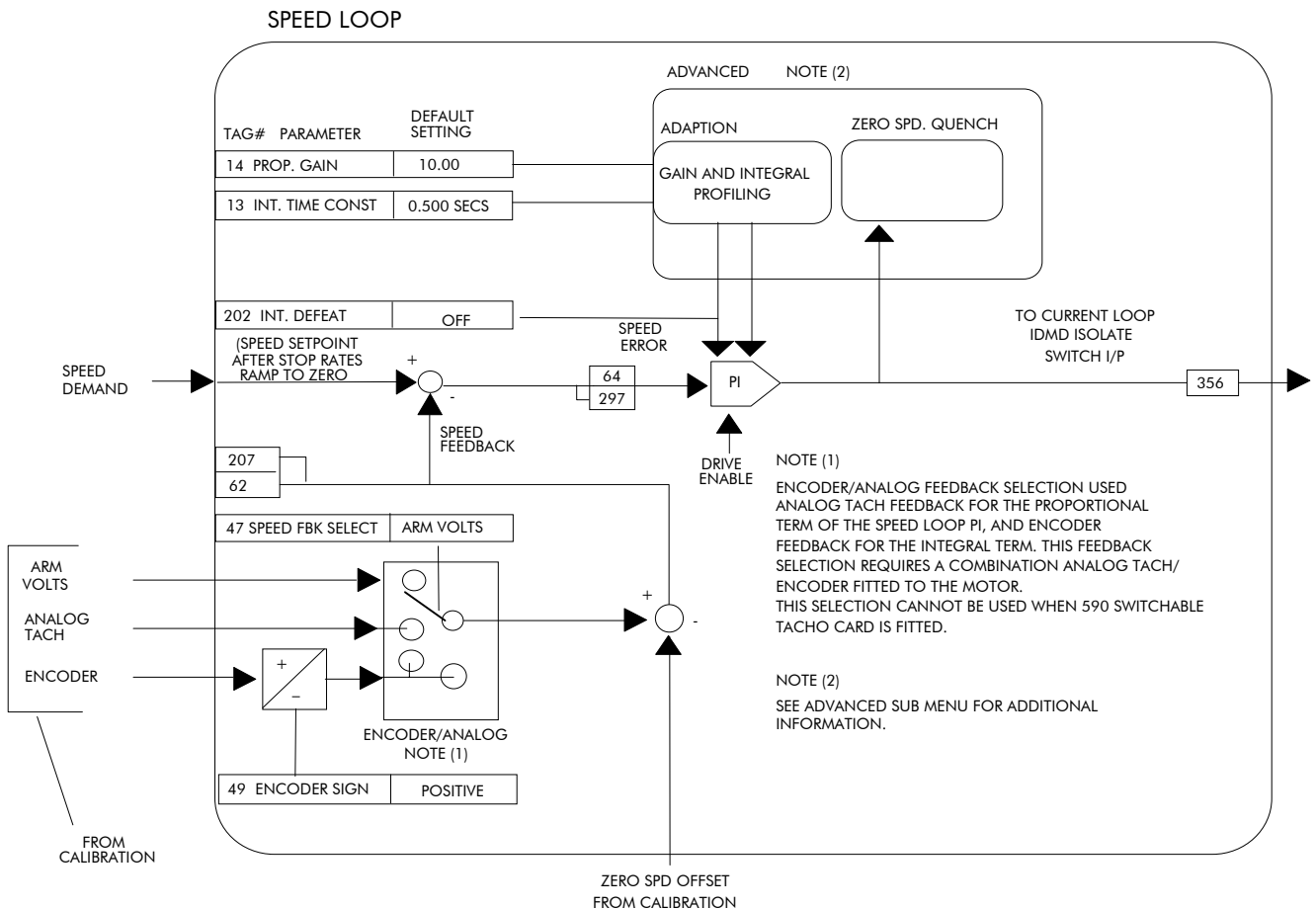

6-62 Programming Your Application

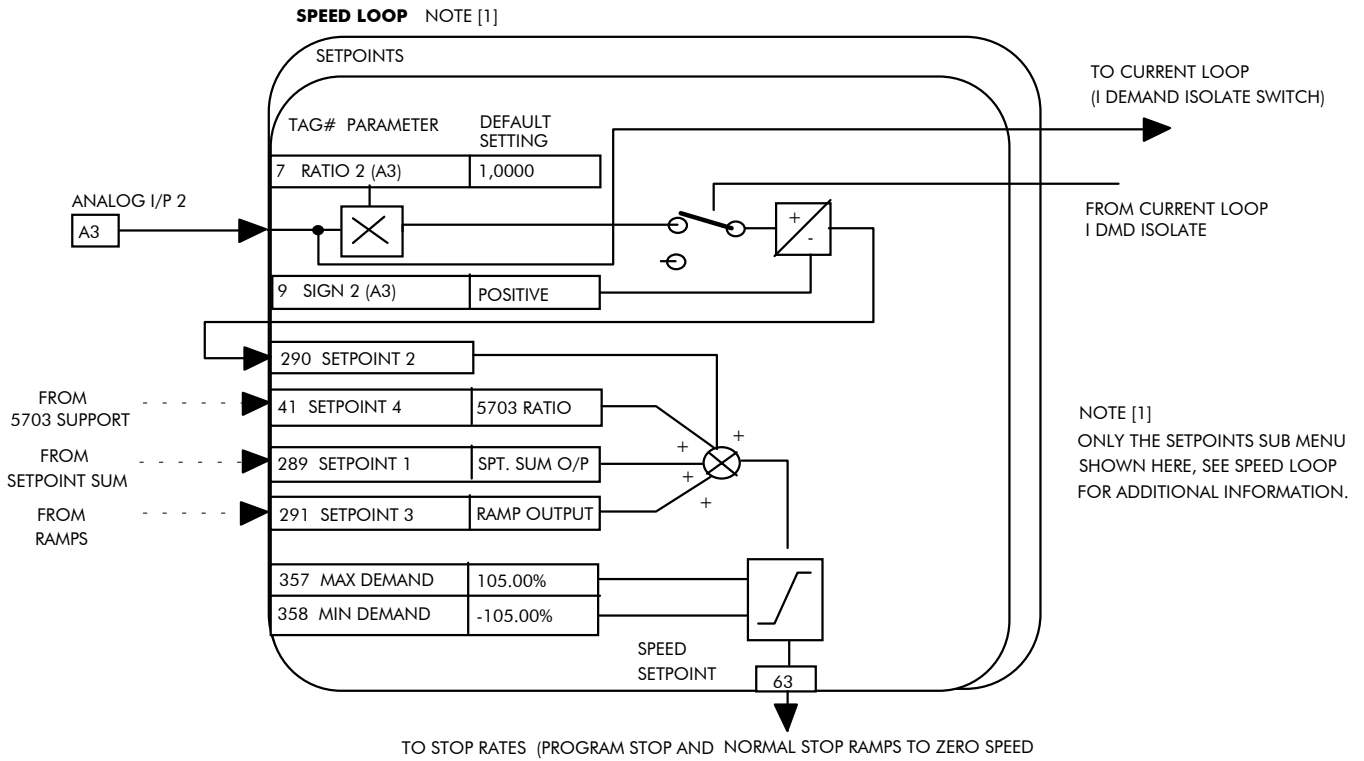

MMI Menu Map

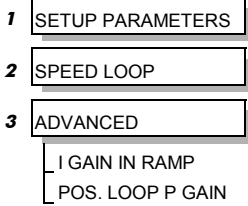

MMI Menu Map

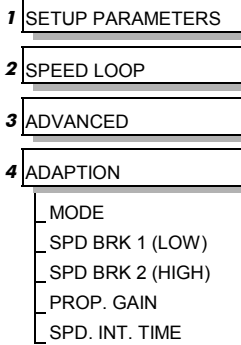

MMI Menu Map

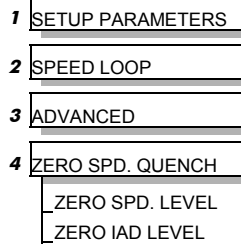

ADVANCED

This function block is viewed in three menus on the MMI and contains the parameters for the advanced-user.

ADAPTION

This MMI menu contains parameters for speed loop gain scheduling.

ZERO SPD. QUENCH

Similar to Standstill logic (i.e. it stops making current but keeps the contactor in) except that the speed loop remains enabled and will cause the current loop to unquench very quickly.

Advanced	
0	[268] MODE
1.00 %	[269] SPD BRK 1 (LOW)
5.00 %	[270] SPD BRK 2 (HIGH)
5.00	[271] PROP. GAIN
0.500 SECS	[272] INT. TIME CONST.
1.0000	[274] I GAIN IN RAMP
0.00 %	[273] POS. LOOP P GAIN
0.50 %	[284] ZERO SPD. LEVEL
1.50 %	[285] ZERO IAD LEVEL

Parameter Descriptions

MODE

Range: 0 to 3

- 0 - Disabled
- 1 - Speed Feedback Dependent
- 2 - Speed Error Dependent
- 3 - Current Demand Dependent

SPD BRK 1 (LOW)

Range: 0.00 to 100.00 %

(SPD BRK1 (LOW))

- IF MODE = 1 Then BRK-points correspond to speed feedback.
- ELSE IF MODE = 2 Then BRK-points correspond to speed error.
- ELSE IF MODE = 3 Then BRK-points correspond to current demand.

SPD BRK 2 (HIGH)

Range: 0.00 to 100.00 %

(SPD BRK2 (HIGH))

Above SPD BRK 2 (HIGH) the normal gains (as per main menu above) prevail. Between the two break-points, a linear variation of the gains is implemented.

PROP. GAIN

Range: 0.00 to 200.00

Prop gain used below SPD BRK 1 (LOW)

INT. TIME CONST.

Range: 0.001 to 30.000 SECS

(SPD.INT.TIME)

Integral time constant used below SPD BRK 1 (LOW)

I GAIN IN RAMP

Range: 0.0000 to 2.0000

While the RAMPING (Tag No. 113) flag is TRUE the integral gain is scaled by I GAIN IN RAMP. This can be used to help prevent integral wind-up while the drive is ramping (particularly high inertia loads).

POS. LOOP P GAIN

Range: -200.00 to 200.00 %

Reserved parameter for use by Eurotherm Drives.

ZERO SPD. LEVEL

Range: 0.00 to 200.00 %

Sets the threshold of speed feedback below which Zero Speed Quench is active.

ZERO IAD LEVEL

Range: 0.00 to 200.00 %

Sets the threshold of current feedback below which Zero Speed Quench is active.

MMI Menu Map

1	SETUP PARAMETERS
2	STANDSTILL
	STANDSTILL LOGIC
	ZERO THRESHOLD
	SOURCE TAG

STANDSTILL

Standstill logic is used to inhibit rotation when operating with Zero Speed demand.

If the drive is below the Zero Speed threshold and Standstill logic is enabled, then the speed and current loops are quenched. This prevents shaft oscillation around zero speed.

It is useful in preventing gearbox wear due to “chattering”.

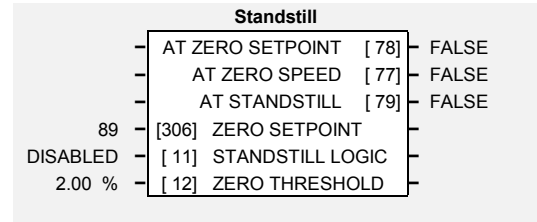

Parameter Descriptions

AT ZERO SETPOINT

Range: See below

Refer to the *DIAGNOSTICS* function block description, page 6-22.

- 0 : FALSE
- 1 : TRUE

AT ZERO SPEED

Range: Same as tag 42

Refer to the *DIAGNOSTICS* function block description, page 6-22.

- 0 : FALSE
- 1 : TRUE

AT STANDSTILL

Range: Same as tag 42

Refer to the *DIAGNOSTICS* function block description, page 6-22.

- 0 : FALSE
- 1 : TRUE

ZERO SETPOINT

Range: 0 to 549

(SOURCE TAG)

Reserved parameter for use by Eurotherm Drives.

STANDSTILL LOGIC

Range: Same as tag 4

If TRUE, the Converter is quenched (although the contactor remains in) when the Speed Feedback and Speed Setpoint values are less than ZERO THRESHOLD.

- 0 : DISABLED
- 1 : ENABLED

ZERO THRESHOLD

Range: 0.00 to 100.00 %

Threshold level which defines zero setpoint and zero speed diagnostic outputs and also controls the zero speed relay output.

Functional Description

Standstill Logic inhibits the controller at zero setpoint and zero speed, i.e. at standstill.

The main contactor remains in and the Run LED remains ON.

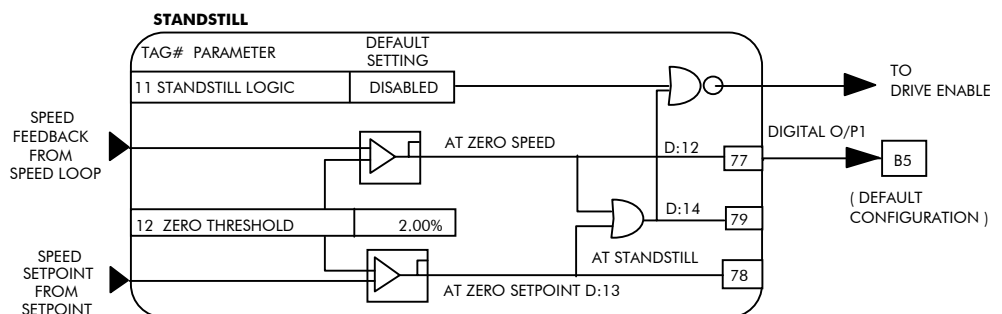
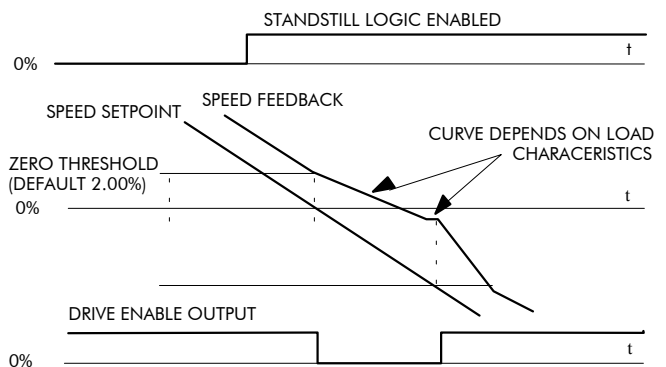

MMI Menu Map

1	SETUP PARAMETERS
2	STOP RATES
	STOP TIME
	STOP LIMIT
	CONTACTOR DELAY
	PROG STOP TIME
	PROG STOP LIMIT
	PROG STOP I LIM
	STOP ZERO SPEED

STOP RATES

This function block holds all the parameters concerning the stopping method of the converter.

The stopping methods of the converter are described in more detail in Chapter 4: “Operating the Converter” - Starting and Stopping Methods.

Stop Rates		
	SPEED DEMAND [89]	0.00 %
	PROGRAM STOP [80]	FALSE
10.0 SECS	[27] STOP TIME	
60.0 SECS	[217] STOP LIMIT	
1.0 SECS	[302] CONTACTOR DELAY	
0.1 SECS	[26] PROG STOP TIME	
60.0 SECS	[216] PROG STOP LIMIT	
100.00 %	[91] PROG STOP I LIM	
2.00 %	[29] STOP ZERO SPEED	

Parameter Descriptions

SPEED DEMAND

Range: xxx.xx %

Refer to the *DIAGNOSTICS* function block description, page 6-22.

PROGRAM STOP

Range: See below

Refer to the *DIAGNOSTICS* function block description, page 6-22.

0 : FALSE
1 : TRUE

STOP TIME

Range: 0.1 to 600.0 SECS

Time to reach zero speed from 100% set speed in normal stop mode (C3 OFF).

STOP LIMIT

Range: 0.0 to 600.0 SECS

Delay time limit to allow normal stop action (regenerative braking) to achieve zero speed before drive quench and coast stop. The timer is triggered by Start command (C3) going low.

CONTACTOR DELAY

Range: 0.1 to 600.0 SECS

This defines the time between the drive reaching STOP ZERO SPEED (Tag No. 29) and the contactor being opened. This is particularly useful during the jog cycle to prevent multiple operations of the main contactor.

If STOP ZERO SPEED is $\geq 0.25\%$, the drive will be quenched during the contactor delay. The Contactor delay is *overridden* by Enable (C5).

Maintain zero speed during contactor delay.

If STOP ZERO SPEED is $< 0.25\%$, the drive will not be quenched until CONTACTOR DELAY expires.

PROG STOP TIME

Range: 0.1 to 600.0 SECS

Time to reach zero speed from 100% set speed in program stop mode(B8 OFF).

PROG STOP LIMIT

Range: 0.0 to 600.0 SECS

Delay time limit to allow program stop action (regenerative braking) to achieve zero speed before drive quench and coast stop. The timer is triggered by Program Stop command (B8) going low.

PROG STOP I LIM

Range: 0.00 to 200.00 %

Main current limit level in program stop mode assuming current limit not overridden by I Profile or Inverse Time limits.

STOP ZERO SPEED

Range: 0.00 to 100.00 %

Zero speed level in program stop and normal stop modes at which the contactor delay timer starts timing-out. At the end of this delay the contactor is de-energised.

See also CONTACTOR DELAY above.

Functional Description

Stop Hierarchy

- Coast Stop - Terminal B9**
 - Disables the drive and opens the contactor via the pilot output
- Enable - Terminal C5**
 - Suspends and resets the Control Loops
- Program Stop - Terminal B8**
 - Independent ramp time
 - Stop Timer
 - Independent Current Limit that may be higher than normal Current Limit
 - Independent zero speed
- Normal Run/Stop - Terminal C3**
 - Independent ramp time
 - Contactor Delay

Note: The Converter's reaction to commands is defined by a state machine. This determines which commands provide the demanded action, and in which sequence. Consequently, COAST STOP and PROGRAM STOP must be FALSE, i.e. the Converter is not in Coast or Program mode, before a Run signal is applied otherwise the controller assumes a Stop mode and remains disabled. Refer to Chapter 4: "Operating the Converter" - Stopping Methods for descriptions of Coast Stop and Program Stop.

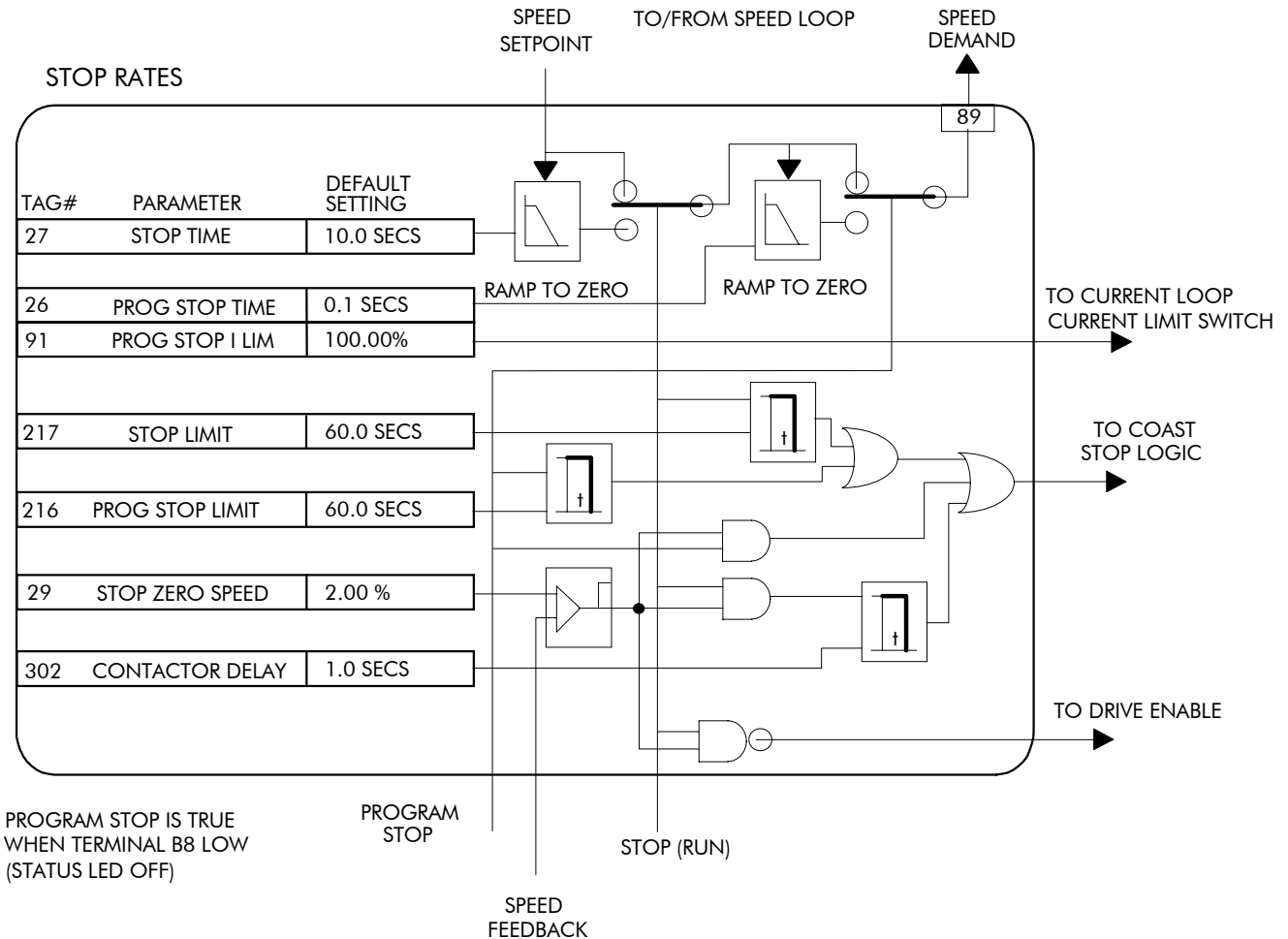

MMI Menu Map

- 1 SERIAL LINKS
- 2 SYSTEM PORT P3
 - _ DUMP MMI (TX)
 - _ UDP XFER (RX)
 - _ UDP XFER (TX)
 - _ VERSION NO.

MMI Menu Map

- 1 SERIAL LINKS
- 2 SYSTEM PORT (P3)
- 3 P3 SETUP
 - _ MODE
 - _ 5703 SUPPORT
 - _ P3 BAUD RATE

MMI Menu Map

- 1 SERIAL LINKS
- 2 SYSTEM PORT (P3)
- 3 P3 SETUP
- 4 BISYNCH SUPPORT
 - _ GROUP ID (GID)
 - _ UNIT ID (UID)
 - _ ERROR REPORT

SYSTEM PORT P3

Refer to Chapter 14: “Serial Communications” - System Port P3 for further information.

This function block contains parameters for configuring the port for connection to ConfigEd Lite (or other suitable PC programming tool), or another VSD.

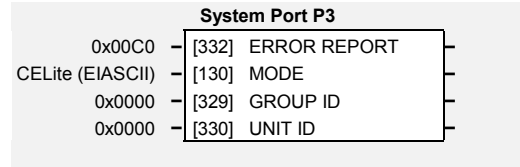

SYSTEM PORT P3

This MMI menu contains parameters for transferring data to and from a PC.

P3 SETUP

This MMI menu contains communication set-up parameters for System Port P3.

5703 SUPPORT

Refer to page 6-68.

BISYNCH SUPPORT

This MMI menu contains parameters for supporting the BISYNCH protocol.

Parameter Descriptions

ERROR REPORT

Range: 0x0000 to 0xFFFF

Displays the last error as a hexadecimal code. Writing any value to this parameter will set the value to >00C0 (No Error). Refer to Chapter 14: “Serial Communications” - Reference for a list of codes.

MODE

Range: See below

Four options are available:

- 0 : DISABLED
- 1 : 5703 MASTER
- 2 : 5703 SLAVE
- 3 : CELite (EIASCII)

P3 BAUD RATE

Range: See below

Four options are available:

- 0 : DISABLED
- 1 : 5703 MASTER
- 2 : 5703 SLAVE
- 3 : CELite (EIASCII)

GROUP ID

Range: 0x0000 to 0x0007

(GROUP ID (GID))

The Eurotherm protocol group identity address.

UNIT ID

Range: 0x0000 to 0x000F

(UNIT ID (UID))

The Eurotherm protocol unit identity address.

6-68 Programming Your Application

MMI Menu Map

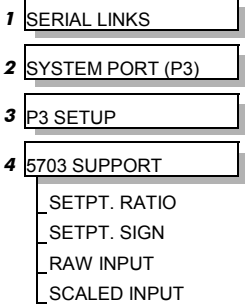

MMI Menu Map

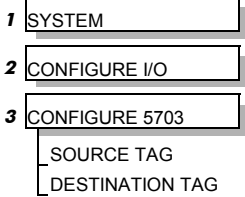

5703 SUPPORT

This function block contains the parameters for connecting a 5703 Setpoint Repeater Unit. The 5703 peer-to-peer communication option transfers parameters from drive to drive through the serial port, P3.

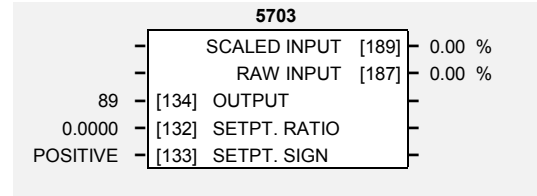

Parameter Descriptions

SCALED INPUT

Scaled input.

Range: xxx.xx %

RAW INPUT

Raw input.

Range: xxx.xx %

OUTPUT

(SOURCE TAG)

Range: 0 to 549

The source tag of the value to be sent to the 5703. The default is 89, SPEED DEMAND.

SETPT. RATIO

Input scaler.

Range: -3.0000 to 3.0000

SETPT. SIGN

Input sign.

Range: See below

- 0 : NEGATIVE
- 1 : POSITIVE

DESTINATION TAG (MMI only) is the destination tag of the value received from the 5703. The default is SETPOINT 4 in the speed loop.

MMI Menu Map

- 1 SETUP PARAMETERS
- 2 SPECIAL BLOCKS
- 3 TAPER CALC.
 - TAPER
 - TENSION SPT.
 - TAPERED DEMAND
 - TENSION TRIM
 - TOT.TENS.DEMAND

TAPER CALC.

The purpose of this block is to profile the tension demand with diameter.

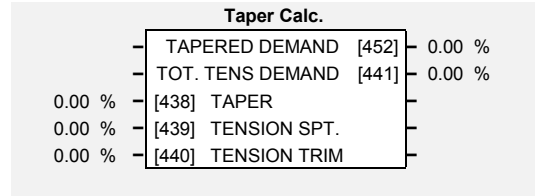

Parameter Descriptions

TAPERED DEMAND

Range: xxx.xx %

This is the output of the TAPER calculation on the TENSION SPT.

TOT. TENS DEMAND

Range: xxx.xx %

(TOT.TENS.DEMAND)

This is the final output of this block (total tension demand) which can be connected to the appropriate points in the block diagram.

TAPER

Range: -100.00 to 100.00 %

This defines the amount of tapering in the tension demand with diameter variation. When TAPER is positive, the tension demand is hyperbolically decreased as diameter increases

TENSION SPT.

Range: 0.00 to 100.00 %

This is the required tension setpoint.

TENSION TRIM

Range: -100.00 to 100.00 %

This is the additional tension demand in the form of a trim.

Functional Description

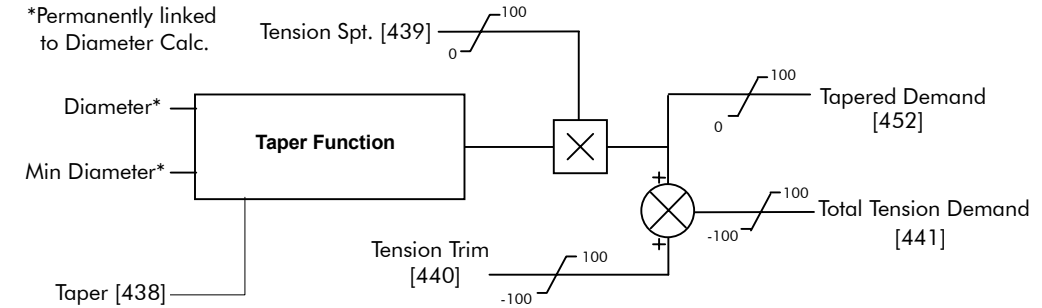

Hyperbolic Taper Tension

The taper block provides hyperbolic taper tension according to the following equation: -

$$\text{Tapered Demand} = \text{Tension Spt} \times \left\{ 100\% - \frac{\text{Taper}}{\text{Diameter}} \times (\text{Diameter} - \text{Min Diameter}) \right\}$$

The taper tension characteristics are shown below: -

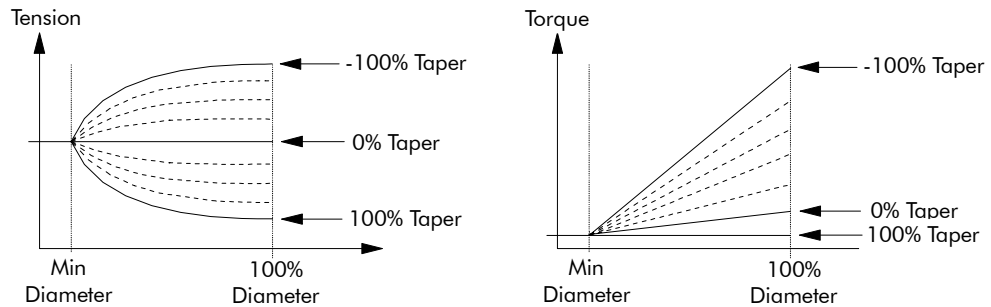

100% taper tension is equivalent to constant torque on the centre wind spindle.

MMI Menu Map

1	SERIAL LINKS
2	TEC OPTION
	TEC OPTION TYPE
	TEC OPTION IN 1
	TEC OPTION IN 2
	TEC OPTION IN 3
	TEC OPTION IN 4
	TEC OPTION IN 5
	TEC OPTION FAULT
	TEC OPTION VER
	TEC OPTION OUT 1
	TEC OPTION OUT 2

TEC OPTION

This function block is used to configure the inputs and outputs of the various Technology Options that can be fitted.

The Technology Option provides a communications interface for external control of the Converter.

Refer to the appropriate Technology Option Technical Manual supplied with the option for further details.

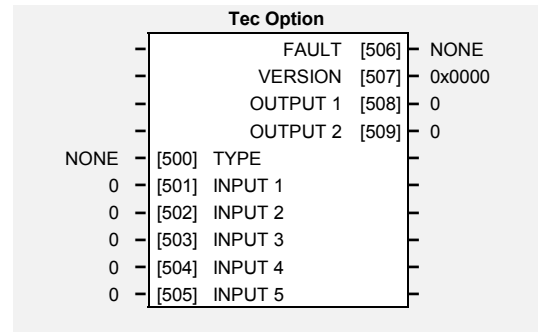

Parameter Descriptions

FAULT

Range: See below

(TEC OPTION FAULT)

The fault state of the Technology Option.

0 : NONE	no faults
1 : PARAMETER	parameter out-of-range
2 : TYPE MISMATCH	TYPE parameter mismatch
3 : SELF TEST	hardware fault - internal
4 : HARDWARE	hardware fault - external
5 : MISSING	no option fitted
6 : VERSION NUMBER	older than Version 2.x

If the VERSION NUMBER error message is displayed, the Technology Option is using software that doesn't fully support the drive; refer to Eurotherm Drives.

VERSION

Range: 0x0000 to 0xFFFF

(TEC OPTION VER)

The version of the Technology Option. If no option is fitted then the version is reset to zero.

OUTPUT 1 to OUTPUT 2

Range: xxxxx

(TEC OPTION OUT 1 to TEC OPTION OUT 2)

The use of these output parameters depends upon the type of Technology Option fitted. Refer to the Technology Option Technical Manual.

TYPE

Range: See below

(TEC OPTION TYPE)

Selects the type of Technology Option.

0 : NONE
1 : RS485
2 : PROFIBUS DP
3 : LINK
4 : DEVICE NET
5 : CAN OPEN
6 : LONWORKS
7 : TYPE 7

INPUT 1 to INPUT 5

Range: -32768 to 32767

(TEC OPTION IN 1 to TEC OPTION IN 5)

The use of these input parameters depends upon the type of Technology Option fitted. Refer to the Technology Option Technical Manual.

TENS+COMP CALC.

This block, Tension + Compensation Calculator, compensates for static and dynamic friction, as well as the load inertia.

It achieves this by profiling the motor torque demand as a function of speed and acceleration.

Tension & Comp		
-	TENS+COMP [478]	0
-	INERTIA COMP [485]	0.00 %
0.00 %	[487] STATIC COMP	
0.00 %	[488] DYNAMIC COMP	
ENABLED	[489] REWIND	
0.00 %	[479] FIX. INERTIA COMP	
0.00 %	[480] VAR. INERTIA COMP	
100.00 %	[481] ROLL WIDTH/MASS	
0.00 %	[498] LINE SPEED SPT	
10	[482] FILTER T.C.	
10.00	[483] RATE CAL	
0.00 %	[484] NORMALISED dv/dt	
1.0000	[486] TENSION SCALER	

MMI Menu Map

- 1 SETUP PARAMETERS
- 2 SPECIAL BLOCKS
- 3 TENS+COMP CALC.
 - STATIC COMP
 - DYNAMIC COMP
 - REWIND
 - FIX.INERTIA COMP
 - VAR.INERTIA COMP
 - ROLL WIDTH/MASS
 - LINE SPEED SPT
 - FILTER T.C.
 - RATE CAL
 - NORMALISED dv/dt
 - INERTIA COMP O/P
 - TENSION SCALER

Parameter Descriptions

TENS+COMP

(TENS+COMP CALC.)

Destination tag.

Range: 0 to 549

INERTIA COMP

(INERTIA COMP O/P)

Monitor point on the total inertia compensations.

Range: xxx.xx %

STATIC COMP

Static friction compensation set-up parameter.

Range: -300.00 to 300.00 %

DYNAMIC COMP

Variable friction compensation set-up parameter.

Range: -300.00 to 300.00 %

REWIND

Switches the sign of the friction compensations when the motor changes direction. This should be done when the line reverses.

Range: See below

- 0 : DISABLED
- 1 : ENABLED

FIX. INERTIA COMP

(FIX.INERTIA COMP)

Fixed inertia compensation set-up parameter.

Range: -300.00 to 300.00 %

VAR. INERTIA COMP

(VAR.INERTIA COMP)

Variable inertia compensation set-up parameter.

Range: -300.00 to 300.00 %

ROLL WIDTH/MASS

Scales the inertia compensations dependant on roll width. 100% is maximum roll width.

Range: 0.00 to 100.00 %

LINE SPEED SPT

Used to calculate the line speed acceleration rate value for the inertia compensations.

Range: -105.00 to 105.00 %

FILTER T.C.

The line speed acceleration rate value is calculated from the line speed input. The calculated rate value may have a large ripple content which will disturb the motor torque. The rate signal is therefore filtered, and this filter has a time constant given by this parameter.

Range: 0 to 20000

MMI Menu Map

- 1 SYSTEM
- 2 CONFIGURE I/O
- 3 BLOCK DIAGRAM
 - TENS+COMP CALC.

6-72 Programming Your Application

RATE CAL

Range: -100.00 to 100.00

Scales the inertia compensation acceleration rate value to 100% for the maximum line ramp rate. This parameter should be set to the maximum line full speed ramp rate in Seconds. The resultant rate value can be observed on the NORMALISED dv/dt value.

Note - Inertia compensation does not work well for line ramp rates above 100 secs and therefore this parameter is limited to 100.00.

NORMALISED dv/dt

Range: -300.00 to 300.00 %

1. RATE CAL = 0.00: Allows an externally generated rate signal to be used in place of the calculated value described above. This rate signal must be normalised to 100% for maximum line ramp rate. Useful for large line ramp rates (>100 Secs)
2. RATE CAL not 0.00: Allows the internally calculated rate value to be monitored.

TENSION SCALER

Range: -3.0000 to 3.0000

Scales the Tension Demand which is directly connected from the Taper Calculator.

TORQUE CALC.

This block is used to split the motor current demand and use the appropriate current limit clamp dependant on winding roll direction.

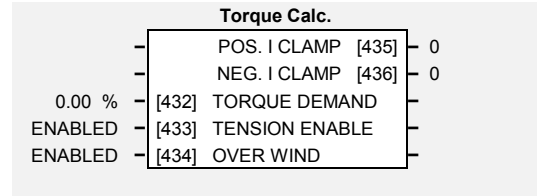

MMI Menu Map

- 1 SETUP PARAMETERS
- 2 SPECIAL BLOCKS
- 3 TORQUE CALC.
 - TORQUE DEMAND
 - TENSION ENABLE
 - OVER WIND

MMI Menu Map

- 1 SYSTEM
- 2 CONFIGURE I/O
- 3 BLOCK DIAGRAM
 - POS. I CLAMP
 - NEG. I CLAMP

Parameter Descriptions

POS. I CLAMP

Range: 0 to 549

Positive clamp output destination. The default is no connection.

NEG. I CLAMP

Range: 0 to 549

Negative clamp output destination. The default is no connection.

TORQUE DEMAND

Range: -200.00 to 200.00 %

This is the torque input of the block.

TENSION ENABLE

Range: See below

When enabled, torque demand is applied. When disabled, the torque demand is zero.

- 0 : DISABLED
- 1 : ENABLED

OVER WIND

Range: See below

When enabled, Over Wind is selected which means the torque demand is applied in the positive quadrant (POS. I CLAMP, Tag No. 301). When disabled, Under Wind is selected which means the torque demand is applied in the negative quadrant (NEG. I CLAMP, Tag No. 48).

- 0 : DISABLED
- 1 : ENABLED

Functional Description

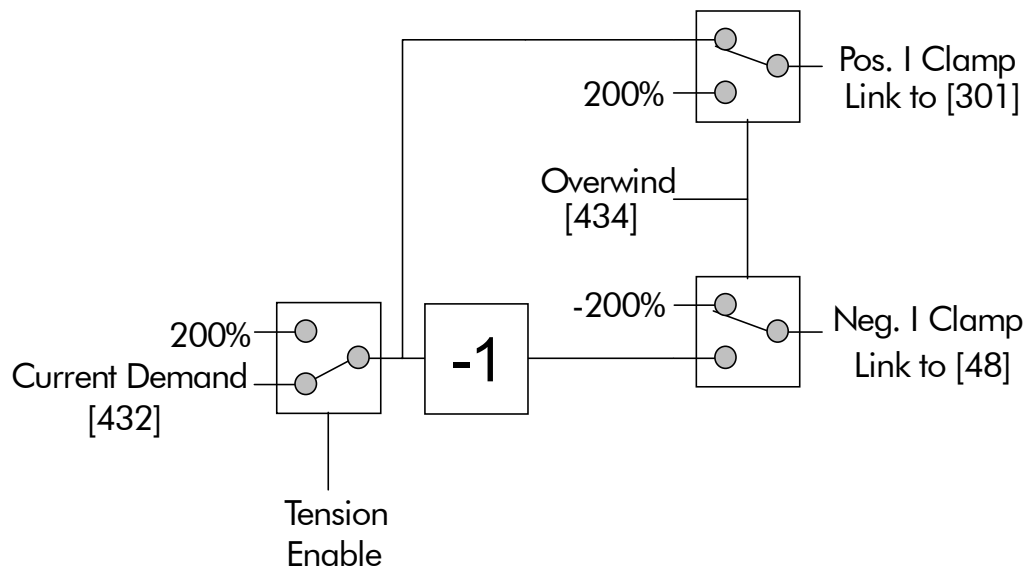

6-74 Programming Your Application

USER FILTER

This is an internal function block and does not appear as a menu on the MMI.

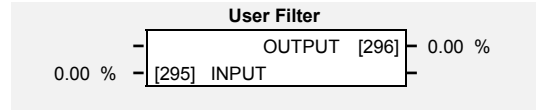

Parameter Descriptions

INPUT

Reserved parameter for use by Eurotherm Drives.

Range: -300.00 to 300.00 %

OUTPUT

Reserved parameter for use by Eurotherm Drives.

Range: xxx.xx %

TRIPS AND FAULT FINDING

Trips

What Happens when a Trip Occurs

When a trip occurs, the Converter's power stage is immediately disabled causing the motor and load to coast to a stop. The trip is latched until action is taken to reset it. This ensures that trips due to transient conditions are captured and the Converter is disabled, even when the original cause of the trip is no longer present.

Converter Indications

If a trip condition is detected the unit displays and performs the following actions.

1. The HEALTH LED goes out indicating a Trip condition has occurred. (Investigate, find and remove the cause of the trip.)
2. Terminal B6 (Healthy) goes low (0V).

Operator Station Indications

If a trip condition is detected the MMI displays and performs the following actions.

1. The HEALTH LED goes out indicating a Trip condition has occurred. The MMI displays the activated alarm. (Investigate, find and remove the cause of the trip.)
2. Terminal B6 (Healthy) goes low (0V).
3. The alarm message(s) can be acknowledged by pressing the E key, however, the unit will not restart at this point.

Resetting a Trip Condition

All trips must be reset before the Converter can be re-enabled. A trip can only be reset once the trip condition is no longer active, i.e. a trip due to a heatsink over-temperature will not reset until the temperature is below the trip level.

Note: *More than one trip can be active at any time. For example, it is possible for both the HEATSINK TRIP and the OVERVOLTS (VA) trips to be active. Alternatively it is possible for the Converter to trip due to a FIELD OVER I error and then for the HEATSINK TRIP trip to become active after the Converter has stopped (this may occur due to the thermal time constant of the heatsink).*

You can reset the trip(s) in one of two ways:

1. Power-up, or remove and re-apply the auxiliary power supply.
2. Stop and start the converter, i.e. remove and re-apply the Start/Run signal (terminal C3 or C4, or the STOP and RUN keys on the MMI).

Success is indicated by the HEALTH LED (on the unit or MMI) illuminating. The MMI will return to its original display.

7-2 Trips and Fault Finding

Fault Finding

Problem	Possible Cause	Remedy
Converter will not power-up	Fuse blown	Check supply details, replace with correct fuse. Check Product Code against Model No.
	Faulty cabling	Check all connections are correct and secure. Check cable continuity
Converter fuse keeps blowing	Faulty cabling or connections wrong	Check for problem and rectify before replacing with correct fuse
	Faulty Converter	Contact Eurotherm Drives
Cannot obtain HEALTH state	Incorrect or no supply available	Check supply details
Motor will not run at switch on	Motor jammed	Stop the Converter and clear the jam
Motor runs and stops	Motor becomes jammed	Stop the Converter and clear the jam
Motor runs at full speed only	Reversed tachogenerator or open circuit tachogenerator	Check tachogenerator connections
	Open circuit speed reference potentiometer	Check terminal

Table 7-1 Fault Finding

Alarm Messages

When a trip occurs an alarm message is displayed on the MMI, and information about the trip is stored in the ALARM STATUS menu.

The alarm message and the LAST ALARM parameter are displayed in the selected language of the MMI.

The HEALTH STORE and HEALTH WORD parameters display information as hexadecimal values, or the sum of the hexadecimal values when more than one alarm is active. Thus the unique value can represent one or more alarms.

Note: *Hexadecimal refers to the common practice of counting to the base of 16 in computing rather than the base of 10. The sixteen 'numbers' used being 0 to 9, A to F. Thus an 8 bit byte is represented by two characters in the range 00 to FF, while a 16 bit word is represented by four characters in the range 0000 to FFFF.*

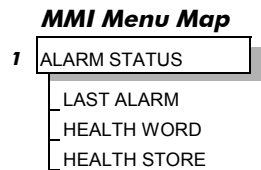

LAST ALARM

(Tag 528). This display shows the last alarm message to have been displayed. To reset the parameter simply press the ▼ (DOWN) key to clear the alarm. Alternatively, you can switch the auxiliary supply off and on, causing NO ACTIVE ALARMS to be displayed.

HEALTH WORD

(Tag 115). This parameter is used to continuously monitor the status of the Converter. As alarms are added or removed, the display will immediately update to show the hexadecimal sum of these alarms.

The value reverts to 0x0000 when the Start (C3) input is raised (+24V), and when no trip condition is present.

HEALTH STORE

(Tag 116). This displays the hexadecimal value of the first (or only) alarm to occur causing the trip condition.

The display reverts to 0x0000 when the Start (C3) input is raised (+24V).

Hexadecimal Representation of Trips

The LAST ALARM, HEALTH WORD and HEALTH STORE parameters use a four digit hexadecimal number to identify individual trips. Each trip has a unique corresponding number as shown below.

LAST ALARM, HEALTH WORD and HEALTH STORE					
Trip		Trip Code			
		First Digit	Digit	Digit	Last Digit
	NO ACTIVE ALARMS				
0	OVERSPEED				1
1	MISSING PULSE				2
2	FIELD OVER I				4
3	HEATSINK TRIP *				8
4	THERMISTOR			1	
5	OVER VOLTS (VA)			2	
6	SPD FEEDBACK			4	
7	ENCODER FAILED			8	
8	FIELD FAILED		1		
9	3 PHASE FAILED *		2		
10	PHASE LOCK		4		
11	5703 RCV ERROR		8		
12	STALL TRIP	1			
13	OVER I TRIP	2			
14	OTHER •	4			
15	ACCTS FAILED *	8			
* Refer to "Power Board LED Trip" below					
• For the LAST ALARM parameter, OTHER is replaced with the trip codes below.					

LAST ALARM only					
14	AUTOTUNE ERROR	F	0	0	1
14	AUTOTUNE ABORTED	F	0	0	2
14	EXTERNAL TRIP	F	0	0	5
14	REMOTE TRIP	F	0	0	6
14	CONFIG ENABLED	F	2	0	0
14	NO OP-STATION	F	4	0	0
14	PCB VERSION	F	F	0	5
14	PRODUCT CODE	F	F	0	6

When more than one trip is to be represented at the same time then the trip codes are simply added together to form the value displayed. Within each digit, values between 10 and 15 are displayed as letters A to F

For example, if the HEALTH WORD parameter is **01A8** then this represents a "1" in digit 3, an "8" and a "2" in digit 2, (8+2 = 10, displayed as A) and an 8 in digit 1. This in turn represents the active trips FIELD FAILED, ENCODER FAILED, OVER VOLTS (VA) and HEATSINK TRIP (an unlikely situation).

Decimal number	Display
10	A
11	B
12	C
13	D
14	E
15	F

7-4 Trips and Fault Finding

Power Board LED Trip Information (Frame 4, 5 & H)

The HEATSINK TRIP, 3 PHASE FAILED and ACCTS FAILED trips are associated with the following LED indications:

Frame 4

Check the LEDs on the power board for more HEATSINK TRIP information.

The LEDs light to indicate a problem.

<u>Trips</u>		
HEATSINK TRIP	field heatsink overtemperature	FLD HS OT <input type="checkbox"/>
	armature heatsink overtemperature	ARM HS OT <input type="checkbox"/>
3 PHASE FAILED	phase loss	PHASE LOSS <input type="checkbox"/>

Frame 5

The master power board (on the left hand side of the unit) is fitted with a Parallel Expansion Board. This board has four additional LEDs providing information about the slave power board (on the right hand side of the unit), and about the general status of the unit.

The LEDs light to indicate a problem.

<u>Trips</u>	Master Power Board	Slave Power Board (indicated by the Parallel Expansion Board)
HEATSINK TRIP	field heatsink overtemperature	FLD HS OT <input type="checkbox"/>
	armature heatsink overtemperature	ARM HS OT <input type="checkbox"/>
3 PHASE FAILED	phase loss	PHASE LOSS <input type="checkbox"/>
	phase rotation fault	PH ROT FLT <input type="checkbox"/>
ACCTS FAILED	current imbalance	CUR IMBALANCE <input type="checkbox"/>

It is essential that the phase sequence applied to the two stacks are identical otherwise the converter will trip on 3 PHASE FAILED.

If there is a current imbalance between the stacks which exceeds 10% the converter will trip on ACCTS FAILED.

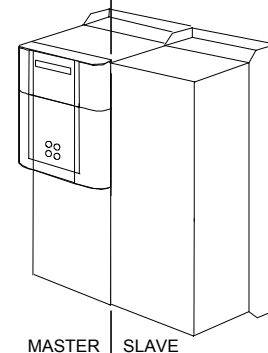

Frame H

The power board has six LEDs indicating further trip information, and general status of the unit.

The LEDs go out to indicate a problem (note that LED1 may also flash as the SMPS attempts to power-up repeatedly, indicating a fault).

<u>Trips</u>		Power Board
	switched mode power supply on	SMPS OK <input type="checkbox"/> LED1
ACCTS FAILED	trigger board connection status	TRIGGER BOARD PRESENT <input type="checkbox"/> LED4
	ac current transformer connection status	ACCTS PRESENT <input type="checkbox"/> LED3
3 PHASE FAILED	thyristor fuses status	THYRISTOR FUSES <input type="checkbox"/> LED6
HEATSINK TRIP	field heatsink temperature normal	FIELD HEATSINK <input type="checkbox"/> LED2
	armature heatsink temperature normal	STACK THERMOSTATS <input type="checkbox"/> LED5

Using the MMI to Manage Trips

Trip Messages

Most of the alarms have a delay timer so that the Converter only trips if the condition persists for the whole of the delay period.

If the Converter trips, then the display immediately shows a message indicating the reason for the trip. The possible trip messages are given in the table below.

Trip Message and Meaning	Possible Reason for Trip
<p>OVERSPEED</p> <p>Motor overspeed - the speed feedback signal has exceeded 125% of rated speed.</p>	<p>Badly adjusted speed loop (alarm only operates with encoder or armature volts feedback selected)</p> <p>Alarm time delay : 0.1 seconds</p>
<p>MISSING PULSE</p> <p>A missing pulse from the 6-pulse armature current waveform. Trips when the motor loading exceeds 1.5 times the DISCONTINUOUS parameter value.</p>	<p>Firing plug failure</p> <p>Connection failure</p> <p>Alarm time delay : 60 seconds</p>
<p>FIELD OVER I</p> <p>The motor field current has exceeded 120% of the calibrated value</p>	<p>Regulator failure</p> <p>Badly tuned control loop (alarm only operates with field current control mode selected)</p> <p>Alarm time delay : 15 seconds</p>
<p>HEATSINK TRIP</p> <p>The Converter heatsink temperature is too high</p>	<p>The ambient air temperature is too high</p> <p>Poor ventilation or spacing between Converters</p> <p>Fan failure, check fuse on power board, wrong rotation (models above 70A bridge rating)</p> <p>Blocked ventilation slots</p> <p>Clogged air filters</p> <p>Excessive armature current - nominal armature current on motor nameplate should be checked against the current calibration for the Converter.</p> <p>Note: <i>The stack must be allowed to cool in order to re-start the Converter.</i></p> <p>Alarm time delay : 0.75 seconds</p>
<p>THERMISTOR</p> <p>The motor temperature is too high</p>	<p>Inadequate ventilation</p> <p>Blower failure -check for direction, clogged air filters (models above 70A bridge rating)</p> <p>Excessive armature current - check nominal armature current on nameplate against current calibration)</p> <p>Note: <i>The motor must be allowed to cool in order to re-start the Converter.</i></p> <p>Alarm time delay : 15 seconds</p>
<p>OVER VOLTS (VA)</p> <p>Motor armature voltage has exceeded 120% of rated volts</p>	<p>Loose armature connection</p> <p>Badly adjusted field voltage setting</p> <p>Badly adjusted field current loop</p> <p>Badly adjusted field-weakening bemf loop</p> <p>Badly adjusted speed loop</p> <p>Alarm time delay : 1.5 seconds</p>

7-6 Trips and Fault Finding

Trip Message and Meaning	Possible Reason for Trip
<p>SPEED FEEDBACK</p> <p>The difference between speed feedback and armature voltage feedback is greater than the SPDFBK ALM LEVEL parameter value</p> <p>If FLD WEAK ENABLE parameter is enabled, speed feedback is less than 10% when in the field weakening region</p>	<p>Analog tacho feedback polarity incorrect (terminals G3 and G4)</p> <p>The ENCODER SIGN parameter's polarity is incorrect</p> <p>Disconnection of wiring, including fibre optics</p> <p>Tachogenerator failure</p> <p>Tachogenerator coupling failure</p> <p>Alarm time delay : 0.4 seconds</p>
<p>ENCODER FAILED</p> <p>No speed feedback signal</p>	<p>The SPEED FBK SELECT parameter is set to ENCODER but an optional Encoder board is not fitted</p> <p>Where applicable, check fibre optic cable for damage, bend radius, operating length - refer to Microtach handbook.</p> <p>Check cable and connections on wire-ended encoder</p>
<p>FIELD FAIL</p> <p>Field current is less than 6% of rated current when in Current Control mode</p> <p>Field current is less than 50mA when in Voltage Control mode (with default current burden of 15K)</p>	<p>Open circuit motor field - check connection and measure field resistance</p> <p>Faulty operation of field controller</p> <p>Where an ac supply feeds the onboard field regulator, check connections FL1 & FL2 for line-to-line voltage (rather than line-to-neutral) - L1 into FL1, L2 into FL2. Note that the 3-phase supply must be present for mains synchronisation purposes.</p> <p>For loads where no field supply is required, e.g. a permanent magnet motor, set the FIELD ENABLE parameter to disable to suspend this alarm.</p> <p>Alarm time delay : 0.75 seconds</p>
<p>3-PHASE FAILED</p> <p>3-phase supply failure</p>	<p>Total failure of supply, or missing phase of 3-phase supply (detected under most circumstances) - check supply to the controller, check high-speed thyristor stack protection fuses, check power chassis coding fuses.</p> <p>Check the mains voltage of the Converter (refer to Product Code). This alarm may not operate properly with controller if the voltage is incorrect, i.e. wrong unit or controller.</p>
<p>PHASE LOCK</p> <p>Supply frequency is outside the frequency band limits 45 - 65Hz</p>	<p>Check supply frequency</p> <p>Synchronisation errors caused by distorted supply</p>
<p>5703 RCV ERROR</p> <p>Invalid data received via P3 port from another Converter</p>	<p>(Alarm only operates when MODE parameter is set to 5703 SLAVE)</p>
<p>STALL TRIP</p> <p>With motor stationary (AT ZERO SPEED parameter shows TRUE), current has exceeded the STALL THRESHOLD parameter value for longer than the STALL TRIP DELAY parameter value</p>	<p>(Alarm only operates when the STALL TRIP parameter is enabled).</p>

Trip Message and Meaning	Possible Reason for Trip
<p>OVER I TRIP</p> <p>Current feedback value has exceeded 280% of rated current</p>	<p>(300% loading not exceeding 15ms or 325% not exceeding 6.6ms is acceptable)</p> <p>Motor armature windings failure - check insulation resistance.</p> <p>Badly tuned current loop</p> <p>Faulty Converter - refer to Eurotherm Drives</p>
<p>ACCTS FAILED</p> <p>AC current transformer plug connection to Converter power board missing</p>	<p>Check armature current transformer plug for correct installation.</p> <p>Frame 5 only : Load imbalance between the two parallel power stacks</p> <p>Note: <i>The trip prevents the contactor closing and the current loop activating without armature current feedback - important in the case of external stack controllers where the thyristor stack is remote from the control board.</i></p>
<p>AUTOTUNE ERROR</p> <p>Speed feedback has exceeded 20% of rated speed, or field current feedback has exceeded 6% of rated field current</p>	<p>(Alarm only operates during the Autotune sequence).</p>
<p>AUTOTUNE ABORT</p> <p>The Autotune sequence has been aborted.</p>	<p>Coast Stop, Program Stop, Enable or Start Run terminal(s) disabled during Autotune sequence</p> <p>The AUTOTUNE parameter reset during the Autotune sequence</p> <p>Autotune sequence has timed-out (approximately 2 minutes).</p>
<p>REMOTE TRIP</p>	<p>REM. SEQUENCE parameter Remote Trip flag set to zero.</p>
<p>CONFIG INHIBIT</p>	<p>The drive was requested to start whilst in Configuration mode.</p>
<p>CALIB INHIBIT</p>	<p>Calibration fault</p>
<p>COMMS FAULT CODE x</p>	<p>Operator Station faulty</p>
<p>OP STATION</p>	<p>Operator Station has been disconnected from Converter whilst Converter is running in local control.</p>
<p>0xF100 ERROR CAM FULL INIT 0xFF02 UNIMPLEMENTED OPCODE 0xFF03 ERROR NMI 0xFF04 ERROR TRAP 0xFF05 ERROR PCB VERSION 0xFF06 ERROR PRODUCT CODE 0xFF07 ERROR HSO FULL</p>	<p>These are internal software errors. If these should occur please contact Eurotherm Drives Technical Support.</p>

Table 7-1 Trip Messages

7-8 Trips and Fault Finding

Symbolic Alarm Messages

These are generally internal software or hardware. If these should occur please investigate, or contact Eurotherm Drives Technical Support.

Number	Description	Action
0xF003	Pre-Ready Fault	Coding not present. Replace power board or chassis.
0xF004	Aux Contactor Open	The internal auxiliary 3-phase contactor failed to close.
0xF005	External Trip	Ext Trip (C2) open circuit.
0xF006	Remote Trip	REM. SEQUENCE parameter Remote Trip flag set to zero.
0xFF03	Aux Power Fail	Check Aux. Supply and/or Mains Input

Self Test Alarms

Self Test Alarm and Meaning	Possible Reason for Alarm
(EEPROM) CHECKSUM FAIL Parameters not saved, or are corrupted.	(The alarm appears at power-up or at the end of "Upload" UDP Transfer) Corrupted UDP file loaded - press the E key and perform a PARAMETER SAVE. The Converter will be returned to its factory default values.
ENABLE CONFIG. The ENABLE CONFIG. parameter has been left in the Enable state.	Select Disable for the ENABLE CONFIG. parameter
LANGUAGE CHECKSUM FAIL Incorrect language selected, or corrupted	(The alarm appears at power-up or at the end of "Upload" UDP Transfer) Corrupted UDP file loaded - press the E key and reload the correct language or de-select the second language.
INIT CAL FAIL Self calibration of analog inputs has exceeded normal tolerance	(The alarm appears at power-up) As a temporary measure, the tolerance can be increased by 0.1% with each press of the E key, however, this indicates a hardware fault - refer to Eurotherm Drives.
IA FBK CAL FAIL / IA INST CAL FAIL The self calibration of the armature current has failed	(The alarm appears at power-up) If powering the unit off and on does not remove the problem, a hardware failure is suspected. Refer to Eurotherm Drives.

Setting Trip Conditions

The following parameters in the CALIBRATION menu are used to set trip conditions:

OVER SPEED LEVEL
SPDFBK ALM LEVEL
STALL THRESHOLD
STALL TRIP DELAY
REMOTE TRIP DELAY

Viewing Trip Conditions

The following parameters in the ALARM STATUS menu can be viewed to investigate trip conditions:

- LAST ALARM
- HEALTH WORD
- HEALTH STORE
- THERMISTOR STATE
- SPEED FBK STATE
- STALL TRIP
- REMOTE TRIP

Inhibiting Alarms

The following alarms can be inhibited in the INHIBIT ALARMS menu.

- SPEED FBK ALARM
- ENCODER ALARM
- FIELD FAIL
- 5703 RCV ERROR
- STALL TRIP
- TRIP RESET
- REM TRIP INHIBIT

Note: The STALL TRIP parameter in the DIAGNOSTICS menu is set regardless of the state of STALL TRIP inhibit. The flag is set after the stall time-out expires. The relevant bit (bit 12) in the HEALTH WORD and HEALTH STORE parameters is only set when STALL TRIP is enabled.

Test Points

The following test points are located on the control board and can be accessed through the Technology Option housing. When used with a meter, they will provide valuable information in the event of a fault. Refer to Eurotherm Drives for further information.

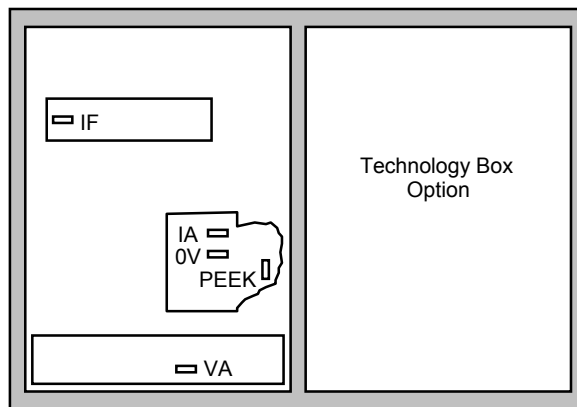

Test Point	Description
IF	Field current feedback 0.0V = 0% 4.0V = 100% (mean voltage), value of FIELD I FBK diagnostic, Tag No. 300
IA	Armature current feedback ± 1.1V ≅ ±100% (mean current), value of CURRENT FEEDBACK diagnostic, Tag No. 298
VA	Armature volts feedback ±10V ≅ ±100% calculated VA (mean voltage), value of TERMINAL VOLTS diagnostic, Tag No. 57
0V	0V
PEEK	PEEK software (Eurotherm Drives use)

7-10 Trips and Fault Finding

ROUTINE MAINTENANCE AND REPAIR

Maintenance

Because of its solid state design, the 590+ Digital drive has few items requiring service or maintenance. Service typically is a matter of replacing fuses, checking electrical contacts, and isolating problems in the overall system application.

Caution

Service procedures must be performed by qualified personnel with an understanding of the dangers inherent in high voltage applications and the precautions necessary when servicing industrial equipment. The customer is responsible for assessing the technical competency of in-house service personnel.

Service Procedures

Required Tools and Equipment

Tools needed for routine service operations include basic hand tools — screwdrivers, wrenches, etc.

WARNING!

Only qualified service personnel should attempt to repair or replace parts in the 590+.

Isolate the entire 590+ drive from electrical power before attempting to work on it.

Preventive Maintenance

You should perform regular preventive maintenance every six months to ensure long life and continued usefulness of the 590+. Keep the drive and its components clean, check auxiliary fans if fitted, and make sure connections and mounting bolts have not loosened from vibration.

The control and field wires can be checked by gently attempting pulling the wires out of the terminals. The terminals should hold the wires firmly in place.

All the remaining wires should be checked with a torque wrench. Refer to Chapter 11: Technical Specifications - Termination Tightening Torque tables.

Repair

There are no user-serviceable components.

IMPORTANT: MAKE NO ATTEMPT TO REPAIR THE UNIT - RETURN IT TO EUROTHERM DRIVES.

Saving Your Application Data

The Converter retains saved settings during power-down. You can download and upload this back into the repaired unit, if necessary. You may, depending upon your knowledge of the fault, attempt the back-up of your application data now, refer to Chapter 5: “The Operator Station” - Copying an Application.

If the fault clearly lies within the MMI, then return the unit for repair.

8-2 Routine Maintenance and Repair

Returning the Unit to Eurotherm Drives

Before calling Eurotherm Drives Customer Service, make sure you have the following information available:

Information	Source
Model number and serial number	590+Digital drive rating label
Motor horsepower, armature current and voltage, field current and voltage, base and top speed ratings	Motor nameplate
Speed voltage feedback per 1000 RPM (analog device), or counts per revolution(digital device)	Speed feedback device nameplate
Applications information and operating environment	System drawings.

Contact your nearest Eurotherm Drives Service Centre to arrange return of the item.

You will be given a *Returned Material Authorisation*. Use this as a reference on all paperwork you return with the faulty item.

Pack and despatch the item in the original packing materials; or at least an anti-static enclosure. Do not allow packaging chips to enter the unit.

Warranty Information

Warranty information precedes the *Contents* at the front of this manual.

Disposal

This product contains materials which are consignable waste under the Special Waste Regulations 1996 which complies with the EC Hazardous Waste Directive - Directive 91/689/EEC.

We recommend you dispose of the appropriate materials in accordance with the valid environmental control laws. The following table shows which materials can be recycled and which have to be disposed of in a special way.

Material	Recycle	Disposal
metal	yes	no
plastics material	yes	no
printed circuit board	no	yes

The printed circuit board should be disposed of in one of two ways:

1. High temperature incineration (minimum temperature 1200°C) by an incinerator authorised under parts A or B of the Environmental Protection Act
2. Disposal in an engineered land fill site that is licensed to take aluminium electrolytic capacitors. Do not dispose of in a land fill site set aside for domestic waste.

Packaging

During transport our products are protected by suitable packaging. This is entirely environmentally compatible and should be taken for central disposal as secondary raw material.

Technical Support Checks

The results of the following checks will be very useful to Eurotherm Drives' Technical Support.

Caution

Please only attempt these checks if you are electrically competent.

Miscellaneous Checks	✓ or ✗
Check 24V present at Terminals C1 to C9 (C1 is 0V) - dc	
Check ±10V present at Terminals B3 and B4 (B1 is 0V) - dc	
Check auxiliary supply present at Neutral & Line, 110/240V ac	
Check the fans rotate, where applicable	

WARNING!
Now isolate the unit completely from all supplies. It may be necessary to remove an armature and field connection to carry out the following checks.

Continuity Test on Fuses Using a Meter	
Check the coding fuses on the power board	
Check the auxiliary fuses etc. (fan fuse, if applicable)	
Diode Check on Power Terminals Using a Meter	
✓ or ✗	
A+ to L1, L2, L3 and Earth Terminal = Open Circuit	
A- to L1, L2, L3 and Earth Terminal = Open Circuit	
Internal Field Check Using a Meter	
✓ or ✗	
All the coding fuses must be OK before continuing with the following checks since the fuses are in the circuit.	
-ve to L1 & +ve to F+ = Diode Drop (approximately 0.5V)	
-ve to L2 & +ve to F+ = Diode Drop (approximately 0.5V)	
-ve to F- & +ve to F+ = Diode Drop (approximately 0.5V)	
-ve to L1 & +ve to F- = Open Circuit	
-ve to L2 & +ve to F- = Open Circuit	
External Field Check Using a Meter	
✓ or ✗	
-ve to FL1 & +ve to F+ = Diode Drop (approximately 0.5V)	
-ve to FL2 & +ve to F+ = Diode Drop (approximately 0.5V)	
-ve to F- & +ve to F+ = Diode Drop (approximately 0.5V)	
-ve to FL1 & +ve to F- = Open Circuit	
-ve to FL2 & +ve to F- = Open Circuit	

Make a note of the Serial No. and Model No.

Serial No.		Model No.	
-------------------	--	------------------	--

Re-establish all connections. All terminals should be secure and not over-torqued.

8-4 Routine Maintenance and Repair

Fuse Replacement (Frame H)

1. Remove the front cover.
2. Unplug the ribbon cables to the trigger boards.
3. Open the swing-frame using the two quick-release fixings at the right hand end.

590+ 4Q Product (Regenerative)

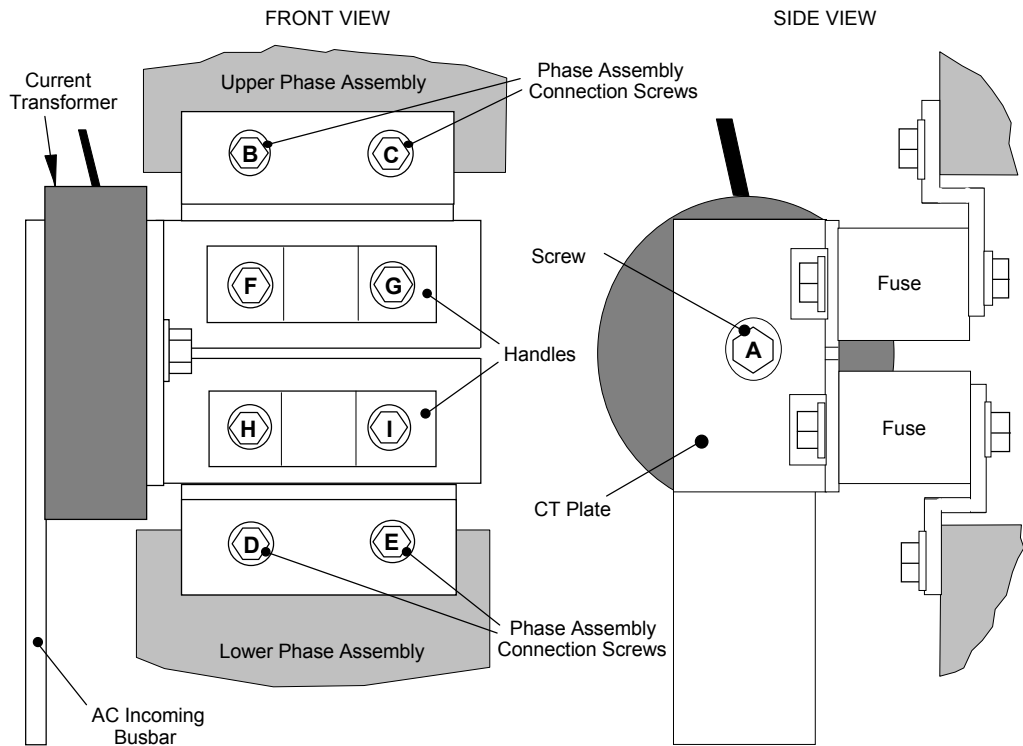

Figure 8-1 590+ (Frame H) Fuse Replacement Diagram

IMPORTANT: When re-assembling the unit, apply a 'zinc-loaded' jointing compound between the fuses and busbars, and between the busbars and phase assemblies (BICC BX1 - Eurotherm Part No. EA466241)

Observe all tightening torque levels, refer to Chapter 11: "Technical Specifications" - Fixing Types and Torques.

Bench-Top Replacement Procedure

1. Disconnect the relevant fuse microswitch assembly by unplugging the lead assembly from the rear trunking.
2. Remove the M12 (A).
3. Loosen (but do not remove) the four M10 screws (B, C, D, E).
4. Hold the fuse assembly handle in one hand and remove the two screws (D, E) from the lower phase assembly.

CAUTION: The fuse assembly weighs 9kg maximum.

5. Hold the fuse assembly handles and remove the two screws (B, C) from the upper phase assembly.
6. With the fuse assembly on the bench, remove the M12 screws (F, G, H, I) holding the fuses to the busbars. **Take a note of the fuse microswitch position on the fuse assembly, do not forget, as the lead assembly will not fit if mounted in the wrong position.**

Reverse the above procedure for replacement. Remember to re-connect the fuse microswitches.

In-Situ Replacement Procedure

1. Disconnect the relevant fuse microswitch assembly by unplugging the lead assembly from the rear trunking.
2. Remove the M12 screw (A), and the 4 screws (F, G, H, I). Remove the CT plate and handles.
3. Remove the relevant screws (B, C or D, E) and lift the fuse busbar assembly from the phase assembly.
4. Replace the fuse on the busbar and re-connect the microswitch. Fully tighten the fuse to the busbar.
5. Fit the fuse busbar assembly on to the phase assembly. Don't fully tighten the screws yet.
6. Position the CT plate on top of the fuses. The slack in the fuse busbar assembly will allow the fixing holes to be aligned. Insert the screws.
7. Fully tighten all screws (including those in 5 above).
8. Re-connect the fuse microswitches.

591 + 2Q Product (Non-Regenerative)

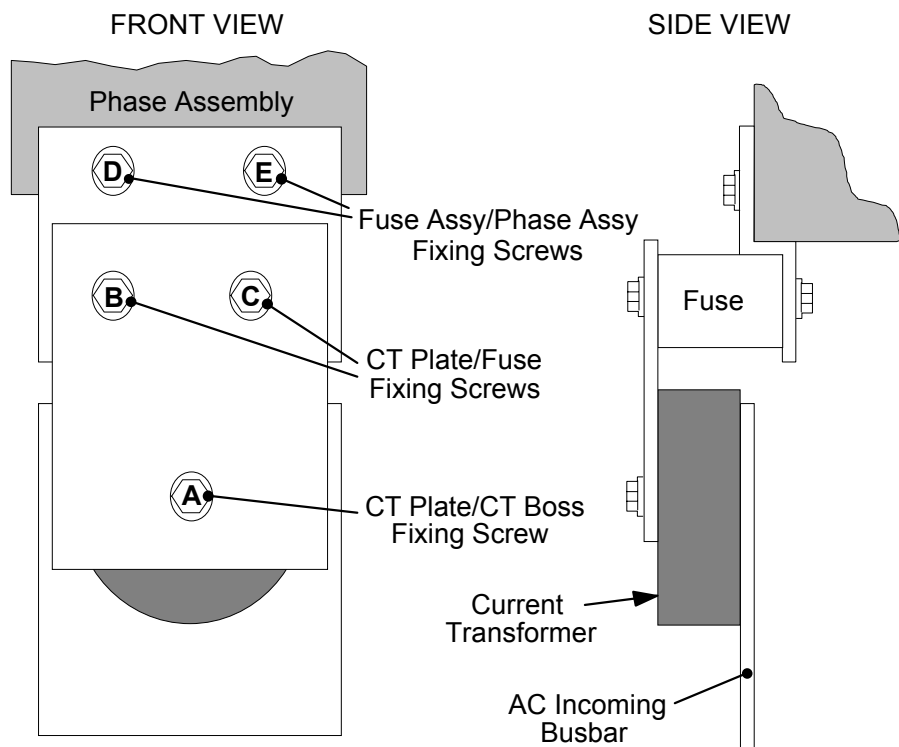

Figure 8-2 591+ Fuse Replacement Diagram

IMPORTANT: When re-assembling the unit, apply a 'zinc-loaded' jointing compound between the fuses and busbars, and between the busbars and phase assemblies (BICC BX1 - Eurotherm Part No. EA466241)

Observe all tightening torque levels, refer to Chapter 11: "Technical Specifications" - Fixing Types and Torques.

Bench-Top Replacement Procedure

Working on the relevant fuse assemblies:

1. Remove the M12 screw (A).
2. Release the two M12 screws (B, C) and remove the CT plate.
3. Remove the two M10 screws (D, E) fixing the fuse assembly to the phase assembly.
4. On the bench, replace the relevant fuse on the fuse assembly.
5. Reverse the procedure for re-fitting.

8-6 Routine Maintenance and Repair

Phase Assembly Replacement (Frame H)

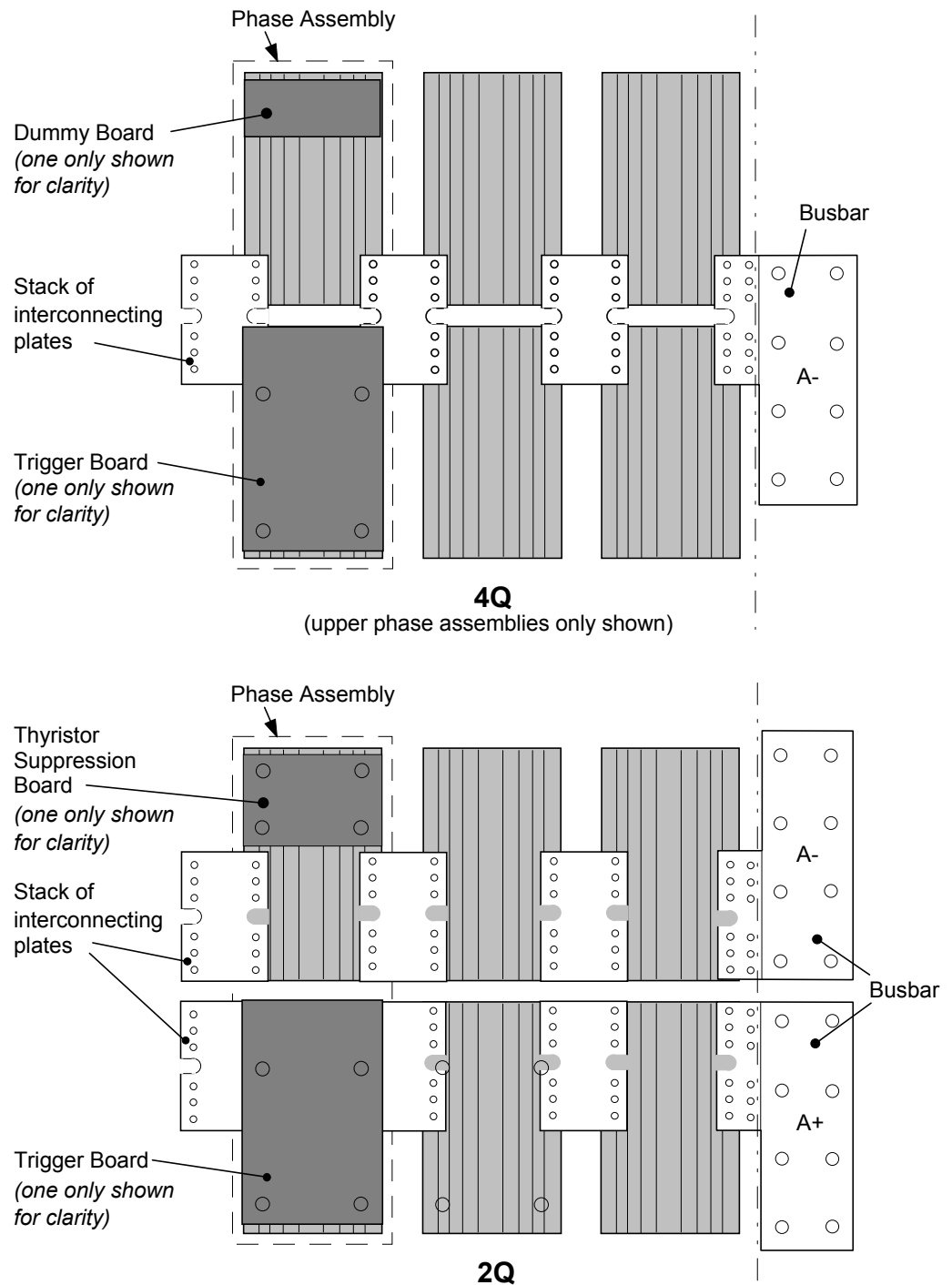

Figure 8-3 Front View of Phase Assemblies

IMPORTANT: When re-assembling the unit, apply a 'zinc-loaded' jointing compound between the fuses and busbars, between the busbars and phase assemblies and between the interconnection plates and the heatsink (BICC BX1 - Eurotherm Part No. EA466241)

Observe all tightening torque levels, refer to Chapter 11: "Technical Specifications" - Fixing Types and Torques.

Phase Assembly Removal Procedure

1. Referring to Figure 8-1 (590+) or Figure 8-2 (591+), remove the M12 screw (A). Undo the four screws (B, C, D, E) which allows the CT plate and fuse assembly to be removed.
2. Unplug the thyristor gate leads and the heatsink overtemperature leads from the relevant phase assembly trigger board. Remove the same leads from the adjacent phase assembly or assemblies (this is necessary to gain complete access to the interconnecting plates.) If you are removing the phase assembly from a 591+ (2Q) product, also disconnect the thyristor suppression lead from the trigger boards.
3. Remove the trigger board by releasing the four M6 Sems nuts fixing the PCB to the assembly. If you are working on a 590+ (4Q), remove the dummy trigger board, or if working on a 591+ (2Q) remove the thyristor suppression board. Remove the air duct from the top of the phase assembly to gain access to the DC interconnection plates.
Do not remove the trigger board support spacers.
4. Remove the DC interconnection plates between the phase assembly and its adjacent assemblies, either output terminals or phase assemblies.
5. If changing an upper phase assembly on a 590+ or 591+ remove the top baffle. This is achieved by pushing out the two end flaps of the plenum chamber and unclipping the top baffle from the top cover baffle stops and the top of the phase assemblies. Remove the vertical baffles between phase assemblies.
6. If changing a lower phase assembly on a 590+, remove the lower air duct.
7. Remove the complete phase assembly by removing the four M6 Sems nuts at the top and bottom of the phase assembly.

Note: *On the 591 + 2Q, the left hand screw retains the phase coding connection which should be pushed to one side before lifting the phase assembly.*

Phase Assembly Fitting Procedure

1. Position the repaired or spare phase assembly on to the back panel spacer. (Remember to re-connect the coding lead to the bottom of the phase assembly when working on a 591+ 2Q).

Check for correct orientation of the assembly. Fix in position with 4 x M6 Sems nuts and tighten to the correct torque level.

Refit the interconnecting plate stacks between the phase assemblies. A stack of three plates are used on a 1200 Amp unit, four on a 1700 Amp unit, five on a 2200 Amp unit and six on a 2700 Amp unit. On a 4Q unit the plates interconnect both the upper and lower thyristors and adjacent phase assemblies. On the 2Q unit the plates interconnect adjacent phase assemblies. Tighten to the correct torque level.

Note: *a) When fitting a spare phase assembly there may be some misalignment to the new phase where the interconnection plates do not fit easily. In this case, loosen the trigger support spacers which will allow adjustment of the support bars. Fit the interconnecting plates and re-tighten all units, including spacers.*

b) When re-assembling the interconnection plates it is important that a good electrical contact is made between the plates and the aluminium heatsink. Apply a layer of 'zinc-loaded' jointing compound between the interconnection plates and the heatsink.

3. Refit the air duct on the phase assembly ensuring that the duct fits inside the side ducting of the phase assembly.
4. Refit the trigger board (thyristor suppression board or dummy board as appropriate) and secure with the M6 Sems nuts.
5. Reconnect the gate leads, thermostat and suppression lead as necessary. The gate leads cannot be fitted incorrectly as they are polarised by the plugs.
6. Re-fit the top baffle (either plenum cover or lower 4Q air duct) and vertical baffles.
7. Replace the fuse.
8. Re-close the swing-frame.
9. Replace the trigger board connectors.

8-8 Routine Maintenance and Repair

Replacing the Fan (Frames 4 & 5)

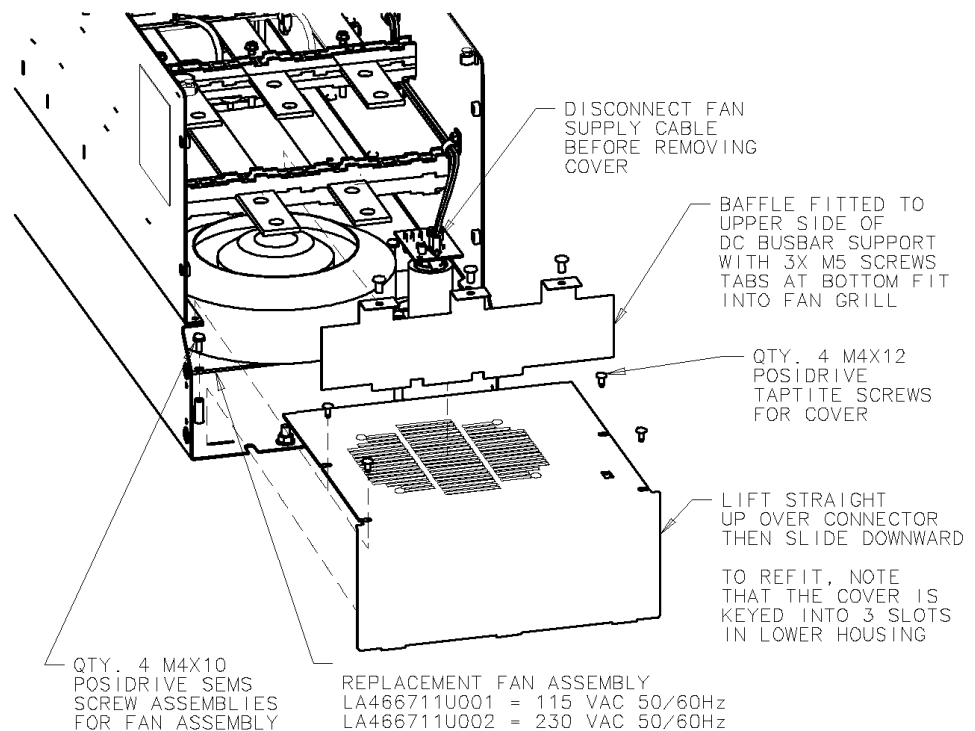

WARNING!

Ensure that all wiring is electrically isolated and cannot be made "live" unintentionally by other personnel.

Remove the terminal cover. Unscrew the three screws securing the baffle and remove. Disconnect the fan supply cable. Remove the two M8 earth/ground screws on the back of the drive (Frame 5). Remove the fan cover. Remove the fan assembly and screws as detailed above.

Reverse the procedure for refitting the fan assembly – refer to the refitting note in the diagram above. The replacement fan assembly includes the fan, cover and capacitor, requiring just a simple connection of the supply cable.

Heatsink Cooling Fan Connections

These fans are connected on the power board to the cooling fan supplies, CONN 2 or 3 as described below:

- 380, 500, 725, 830A models have a single fan matched to the auxiliary supply and connected to CONN 2.
- 1580A models have two fans matched to the auxiliary supply connected to CONN 2 & 3.

CONTROL LOOPS

Principle of Operation

Note: Selection between Current Control or Speed Control (default) is made by the I DMD ISOLATE (current demand isolate) parameter using Digital I/P3 (Terminal C8). If ENABLED the Converter operates as a current controller, and if DISABLED (the default) it operates as a speed controller.

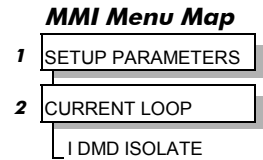

Current Loop

The current loop accepts a demand from either the speed loop, or directly from the plant, and forms an error signal which is the difference between demand and average value of feedback. The error signal is fed into a Proportional + Integral compensator which produces the output of the current loop, i.e. the firing angle signal.

In the Converter, the error signal is created in two different forms:

1. The *average* error is computed as the difference between demand and average value of feedback and fed into the Integral part of the P + I algorithm.
2. The *instantaneous* error is computed as the difference between demand and instantaneous value of feedback and is fed into the Proportional part of the P + I algorithm. This gives higher transient performance since it does not contain any time lag, unlike the average which has a built-in lag of 1/6 of mains cycle. However, the average is the true measurement of torque which is the objective of the current control and this is not affected by the small time lag in achieving zero steady-state error.

The firing angle signal is translated into a certain time delay from the mains zero cross point (obtained via a Phase-Lock-Loop) and this results in a firing command being issued to the thyristor stack every 1/6 of a mains cycle in steady-state.

Some special features of the current controller are discussed separately below.

Adaptive Current Control

The gain of a thyristor 6-pulse converter (voltage-time area over firing angle) drops dramatically at discontinuous values of armature current. Therefore a gain boost is required in the current controller to compensate for that.

In the Converter, this is handled by an adaptive algorithm which allows the current to follow the demand in one step (firing) within the discontinuous region of operation.

Back EMF (BEMF) Estimate

With the motor at standstill, the firing angle for zero current is 120 degrees. When the motor is rotating at different speeds the firing angle for zero current follows a cosine locus.

It is of paramount importance to track this locus as close as possible throughout the speed range if the current loop bandwidth is to be maintained at its highest possible level during current reversals from master to slave bridge and visa-versa.

There are two reasons for the loss of bandwidth at current reversals.

Firstly, the loss of converter gain needs to be compensated in an accurate way which is the objective of the adaptive algorithm.

Secondly, the above algorithm also relies on the right start-up value of firing angle in the incoming bridge in order to minimise both the "dead-time" (time interval of zero current referred to below) as well as the rise time to the required current demand.

In order to get the right start-up value of firing angle the knowledge of the operating BEMF is necessary. In the Converter, this is achieved by a combination of a hardware peak current detector and appropriate software algorithm.

9-2 Control Loops

Bridge Changeover Delay

The bridge changeover "dead-time", i.e. time interval of zero current, is programmable from 1 to 1500 (via Reserved Menu) with a default value of 1.

For values from 1 to 6:

The delay can be set at multiples of 1/6 mains period, i.e. max. $6 \times 3.33 = 20\text{ms}$ at 50Hz. This is relevant for use with large power converters where it is advisable to allow more time for snubber currents to subside before reversal is enabled. It is also relevant for motors with very large armature inductance where zero current detection is more sensitive and therefore a "factor of safety" in the bridge changeover delay is advisable.

For values from 7 to 1500:

The delay corresponds to $7 \times 1.33\mu\text{s}$ up to $1500 \times 1.33\mu\text{s} = 2\text{ms}$ maximum.

Manual Tuning

Note: *This procedure is rarely used or required, if possible use Autotune.*

You may need to perform a manual tuning as Autotune does have two limitations:

1. It requires the field to be switched off and therefore the shaft will need clamping when autotuning a permanent-magnet motor or very rarely with a wound-field motor of relatively high permanent magnetism.
2. Part 1 of Autotune determines the discontinuous to continuous boundary level, i.e. the average value at which the armature current becomes "just" continuous. This is achieved by automatically disabling the field and advancing the firing angle at small steps until the slope of the current "envelope" changes substantially indicating continuous region of operation.

Part 2 of Autotune applies a step change in the current demand within the continuous region as determined by Part 1. When the current feedback approaches the final settling value within 1 to 2 steps, the autotune function terminates and returns the "FIELD ENABLE" to its previous state. The P & I gains and the value of discontinuous boundary current should then be saved.

If the value of boundary current (Part 1) is very high (larger than 150% or so), then the Autotune Part 2 step change will be in the region above 200% which might result in overcurrent trip. In this case it is advisable to set the I gain to a large enough value (typically 10) to give fast response throughout the discontinuous region, a low value for the P gain (typically 1, not important since there is no effective armature time constant in the discontinuous region to compensate for) and finally eliminate the adaptive mode by setting "Discontinuous" to zero. At the same time though, one must disable the Missing Pulse alarm; this is activated when the load current is above the "Discontinuous" level and in this case it would give erroneous trips if left enabled. In order to disable this alarm the special "super-password" reserved for Eurotherm Drives personnel needs to be entered. Next in the "Reserved" menu, which will then appear as a submenu of "SYSTEM", a parameter called "Health Inhibit" should be set to the hexadecimal value 0x002.

The above suggestion assumes that the current limit will prevent the motor from operating in the continuous region, i.e. above 150% in the example above. If this is not the case, as for example when the current limit is set at 200%, then a manual tuning will be necessary.

Set the DISCONTINUOUS parameter to the correct value by disabling or disconnecting the field, set the current limit to zero and start the drive. Gradually increase the current limit observing the current feedback waveform (see Diagnostics below) on an oscilloscope beam. When the pulses "just come together", with no zero interval between them, read the value of current limit (or indeed current demand) and set the DISCONTINUOUS parameter to this value. If this value is very high (above the current limit), then it should be set to zero and follow the suggestion in 2 above. In this case the drive will not perform any adaption in the discontinuous region, so some loss in performance may be noticed in the current loop response.

Subsequently either

- a squarewave signal should be applied to the current demand input (Terminal A3) with Current Demand Isolate (terminal C8) on
- or "toggle" between two values of current limit into terminal A6 and operate in normal speed loop mode.

Ideally this input signal should be offset above the Discontinuous level, such that the drive is operating in the continuous current region. Then you could increase the value of I gain to give a fast rise with no more than 10% overshoot and subsequently increase the P gain towards critically damped response, i.e. practically no overshoot.

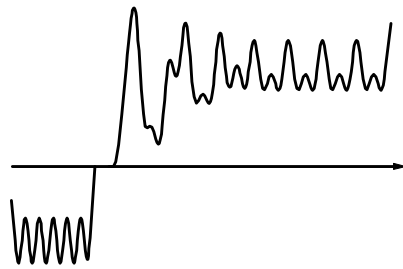

Current Loop controls incorrectly set.
Integral Time Constant too short
increase Current Loop Integral Time Constant

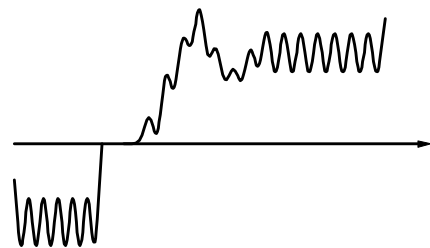

Current Loop controls incorrectly set.
Proportional Gain too low - increase
Current Loop Proportional Gain

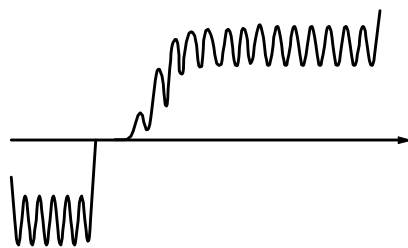

Current Loop response
correctly adjusted.

Tuning Hints

If the I gain is too high, the response will be underdamped (overshoot will be excessive with long oscillatory settling). If the I gain is too low, the response will be overdamped (long exponential rise).

With the I gain optimally set, if the P gain is too low the response will be overdamped. If P is too high the response will revert to underdamped with the tendency to go totally unstable.

Diagnostics

The diagnostic point for "real" armature current is the first (left-hand side) test point below the calibration panel. This will give 1.1V average for 100% current. It will also give the operating bridge, i.e. it will be negative for the Master bridge (positive current demand) and positive for the Slave bridge (negative current demand).

9-4 Control Loops

Speed Loop

The speed loop accepts a demand from either an outside loop (i.e. position loop) or directly from the plant and forms the error signal which is the difference between demand and feedback. The error signal is fed into a Proportional + Integral compensator which produces the output of the speed loop, i.e. the current demand signal.

The integral gain is translated into a Time Constant (secs) in the MMI which defines more clearly the function of the compensator against a certain load time constant.

Speed Loop Synchronised with Current Loop

The proportional part of the P+I algorithm is executed immediately before each run of the current loop, thus ensuring minimum time lag and therefore maximum bandwidth.

Combined Analog Tacho / Encoder Feedback

By using the analog tacho f/b on the Proportional part of the P + I algorithm and the encoder f/b on the Integral part (using similar principle as in the current loop), the Converter combines maximum transient response with the increased steady-state accuracy of the digital feedback. Please refer to Eurotherm Drives Engineering Department for assistance in the use of this feature.

Current Demand Rate Limit (di/dt)

Access to the di/dt limit is currently reserved for Eurotherm Drives personnel only in the Reserved Menu.

This is a limit imposed on the rate of change of the current demand. It is to be used for motors with commutation limitations, mechanical systems that cannot absorb rapid torque transients and also as a means of limiting current overshoot for large current swings (e.g. 0 \rightarrow 200%). The default value is set at 35% (i.e. maximum allowable change is 35% of FLC in 1/6 mains cycle) which has no practical effect on the current response between 0 and 100%.

Field Control

Set-up Notes

The setting of the P + I gains for the current controller is done manually in much the same way as described in Chapter 4: "Current Loop - Manual Tuning", and one convenient way is to switch several times from "quench" to "standby" mode and observe the current response 0 \rightarrow 50% for rise time and overshoot.

The setting of the field weakening gains is achieved by observing the armature voltage feedback for overshoot and settling time. The EMF GAIN parameter defaults to 0.30 (real gain of 30) and normally lies in the region 0.20 to 0.70 (larger settings normally lead to instability). The EMF LEAD parameter should be set at around the time constant for the field current loop. It defaults to 2.00 (200ms). Finally, the EMF LAG parameter defaults to 40.00 (4000ms) and it should generally lie in the region of 10 to 50 times the "emf lead".

The tuning of the field weakening loop is also very dependent on the acceleration rate through base speed and visa-versa. If armature voltage overshoot is a problem for rapid acceleration rates, then the use of the "feedback lead/lag" compensator is recommended to limit the overshoot as discussed above. If not, then the default values for the above bemf fbk gains are recommended (i.e. disabled) which will probably allow further increase in the forward path transfer function gains ("emf gain" and "emf lead") for faster field response.

In summary, the increased attenuation at the higher frequencies will allow an increase in the gain whilst maintaining the desired phase margin. Bearing in mind that the negative angle of the compensator lowers the angle curve, in order to maintain the desired phase margin (45 to 60 degrees) a reduction in the phase-margin frequency is required. This is the frequency at which the log magnitude curve crosses the 0db line. Since the phase-margin frequency is indicative of the speed of response of the system, its reduction should be kept to a minimum. This is achievable by trying to keep the value of the corner-frequency $1 / T1$ as low as possible by setting $T1$ at values greater than 100ms or so. The upper limit for $T1$ will be dictated by the settling time requirement.

Current Control

The field current loop can accept a demand directly from the plant and/or an outside field weakening loop and forms the error signal which is the difference between demand and feedback. The error signal is fed into a P + I compensator which produces the output of the field loop, i.e. the field firing angle signal.

The firing angle signal is translated into a certain time delay from the mains zero cross point (obtained via the same Phase-Lock-Loop as for the armature) and this results into a firing command being issued to the field bridge every 1/2 of a mains cycle in steady-state.

Voltage Control

This offers the facility of an open-loop voltage control for motors which do not provide in the nameplate the field current rating. The field voltage is controlled by the specified RATIO OUT/IN which defaults to 90%. This is the maximum dc Volts that can be obtained for a given ac RMS input in a single-phase rectifier, i.e. 370V dc for 415V ac supply. The specified ratio determines directly the firing angle at which the controller operates and therefore the thermal effects on the field resistance as well as mains voltage variations are not compensated for. It is also worth noting that in this mode the field overcurrent alarm is not active (since there is no current scaling) and therefore this mode is not recommended for use with supplies much greater than the field voltage rating.

Field Weakening

The field weakening loop accepts a demand for MAX VOLTS (default 100%) and forms the error signal which is the difference between demand and arm. volts feedback. The error signal is fed into a Lead/Lag compensator which produces the output of the field weakening loop, i.e. the field weakening demand. This gets subtracted from the field setpoint (default 100%) to produce the field demand into the field current loop. A MIN FLD CURRENT parameter (default 10%) limits the minimum level in the field weakening region.

The Lead/Lag compensator has a dc gain ("emf gain" = Kp), a lead time constant ("emf lead" = T1) and a lag time constant ("emf lag" = T2).

Note: *Field weakening is not possible when running with Armature Volts feedback. Although field weakening can be "enabled" in this instance, a software interlock clamps the field demand at 100% and will not allow the field weakening to reduce it.*

Lead/Lag

The slight disadvantage of Lead/Lag { transfer function = $K_p * (1+sT_1) / (1+sT_2)$ } versus P + I { transfer function = $K_p * (1+sT) / sT$ } is that the DC gain is not "infinity" and therefore there is a "finite" steady-state error. This is kept sufficiently small for values of "emf gain" > 0.20 (i.e. real 20).

The advantage of the Lead/Lag is that it allows greater attenuation at higher frequencies. The high frequency gain is $K_p T_1 / T_2$ and therefore by keeping the ratio T_2 / T_1 high (generally at values above 10) the log magnitude is reduced by $20\log(T_2/T_1)$ for frequencies above $1 / T_1$.

An extra feedback lead/lag compensator has been added into the arm. volts f/b to minimise the overshoot in volts. This is particularly useful when accelerating fast through base speed and therefore increasing the motor bemf at a faster rate than the field current can possibly weaken, due to the normally large field time constant. The ratio of "bemf fbk lead" / "bemf fbk lag" should always be greater than 1 to give a "lead" function to allow the field to start weakening early enough. However, it is not recommended to raise the ratio much higher than 2 to 3 times, otherwise instability will start creeping in. The absolute setting of the above parameters in milliseconds depends on the overall field time constant. The default value is set to 1 (100ms / 100ms) which means that the function is disabled.

Standby Field

When the armature current gets quenched, a timer starts timing-out and after a certain delay ("fld quench delay") it will either quench the field totally ("fld quench mode" = "quench") or will reduce it to 50% of the current or voltage setpoint ("fld quench mode" = "standby"). This applies to both current and voltage modes.

9-6 Control Loops

PARAMETER TABLES

The headings for the Tag No. table are described below.

Tag	A numeric identification of the parameter. It is used to identify the source and destinations of internal links.
Name	The parameter name as it appears on the MMI.
MMI Menu	The menu page under which the parameter is stored on the MMI.
CE Block	The Function Block under which the parameter is stored in the ConfigEd Lite programming software.
Range	<p>This varies with parameter type:</p> <p>INT The upper and lower limits of the parameter, indicating the parameter's true, internally-held, number of decimal.</p> <p>Note: Decimal Places - some internally held parameters with two decimal places are only displayed with one decimal place. These parameters are indicated in the Parameter Description tables. The Range parameter highlights these with "(h)".</p> <p>BOOL 0 = FALSE, 1 = TRUE</p> <p>WORD 0x0000 to 0xFFFF (hexadecimal)</p>
Mn	Serial Communications Mnemonic: Refer to Chapter 14: "Serial Communications"
Notes	<p>Output parameters are not saved in non-vol memory unless noted otherwise.</p> <p>Input parameters are saved in non-vol memory unless noted otherwise.</p> <p><i>Note 1.</i> This input parameter is not saved in non-volatile memory.</p> <p><i>Note 2.</i> This input parameter can only be written to when the drive is stopped.</p> <p><i>Note 3.</i> This input parameter can only be written to when the drive is in configuration mode.</p> <p><i>Note 4.</i> This parameter is reserved</p>

Parameter Types:

Parameters that look like 0x0000 are WORDS

Parameters that have text are BOOLS if they have a range of 0,1

Parameters that have text are WORDS if their range is 0 to greater than 1

All other parameters are INT

If a parameter can only be written to in Config mode, this implies that the drive is stopped.

10-2 Parameter Specification Table

Specification Table: Tag Number Order

Tag	Name	MMI Menu	CE Block	Range	MN Notes
888	NONVOL VERSION	Not on MMI		0x0000 to 0xFFFF	a1
2	RAMP ACCEL TIME	SETUP PARAMETERS::RAMPS	Ramps	0.1 to 600.0 SECS	a2
3	RAMP DECEL TIME	SETUP PARAMETERS::RAMPS	Ramps	0.1 to 600.0 SECS	a3
4	CONSTANT ACCEL	SETUP PARAMETERS::RAMPS	Ramps	0 : DISABLED 1 : ENABLED	a4 4
5	RAMP INPUT	SETUP PARAMETERS::RAMPS	Ramps	-105.00 to 105.00 %	a5
6	RATIO 1	SETUP PARAMETERS::SETPOINT SUM 1	Setpoint Sum 1	-3.0000 to 3.0000	a6
7	RATIO 2 (A3)	SETUP PARAMETERS::SPEED LOOP::SETPOINTS	Speed Loop	-3.0000 to 3.0000	a7
8	SIGN 1	SETUP PARAMETERS::SETPOINT SUM 1	Setpoint Sum 1	0 : NEGATIVE 1 : POSITIVE	a8
9	SIGN 2 (A3)	SETUP PARAMETERS::SPEED LOOP::SETPOINTS	Speed Loop	Same as tag 8	a9
10	ZERO SPD. OFFSET	SETUP PARAMETERS::CALIBRATION	Calibration	-5.00 to 5.00 %	aa
11	STANDSTILL LOGIC	SETUP PARAMETERS::STANDSTILL	Standstill	Same as tag 4	ab
12	ZERO THRESHOLD	SETUP PARAMETERS::STANDSTILL	Standstill	0.00 to 100.00 %	ac
13	SPD.INT.TIME	CONFIGURE DRIVE	Speed Loop	0.001 to 30.000 SECS	ad
14	SPD.PROP.GAIN	CONFIGURE DRIVE	Speed Loop	0.00 to 200.00	ae
15	CUR.LIMIT/SCALER	CONFIGURE DRIVE	Current Loop	0.00 to 200.00 %	af
16	PROP. GAIN	SETUP PARAMETERS::CURRENT LOOP	Current Loop	0.00 to 200.00	ag
17	INT. GAIN	SETUP PARAMETERS::CURRENT LOOP	Current Loop	0.00 to 200.00	ah
18	AUTOTUNE	CONFIGURE DRIVE	Current Loop	0 : OFF 1 : ON	ai 1
19	FIELD FAIL	SETUP PARAMETERS::INHIBIT ALARMS	Alarms	0 : ENABLED 1 : INHIBITED	aj
20	ARMATURE V CAL.	SETUP PARAMETERS::CALIBRATION	Calibration	0.9800 to 1.1000	ak
21	IR COMPENSATION	SETUP PARAMETERS::CALIBRATION	Calibration	0.00 to 100.00 %	al
22	ENCODER RPM	CONFIGURE DRIVE	Calibration	0 to 6000 RPM	am
23	ANALOG TACH CAL	SETUP PARAMETERS::CALIBRATION	Calibration	0.9800 to 1.1000	an
24	ENCODER LINES	CONFIGURE DRIVE	Calibration	10 to 5000	ao 2
25	ARMATURE I (A9)	SETUP PARAMETERS::CALIBRATION	Calibration	0 : UNIPOLAR 1 : BIPOLAR	ap
26	PROG STOP TIME	SETUP PARAMETERS::STOP RATES	Stop Rates	0.1 to 600.0 SECS	aq
27	STOP TIME	SETUP PARAMETERS::STOP RATES	Stop Rates	0.1 to 600.0 SECS	ar
28	STALL TRIP	SETUP PARAMETERS::INHIBIT ALARMS	Alarms	Same as tag 19	as
29	STOP ZERO SPEED	SETUP PARAMETERS::STOP RATES	Stop Rates	0.00 to 100.00 %	at
30	ADDITIONAL DEM	SETUP PARAMETERS::CURRENT LOOP	Current Loop	-200.00 to 200.00 %	au
31	SPD BRK2 (HIGH)	SETUP PARAMETERS::CURRENT PROFILE	Current Profile	0.00 to 100.00 % (h)	av 2
32	SPD BRK1 (LOW)	SETUP PARAMETERS::CURRENT PROFILE	Current Profile	0.00 to 100.00 % (h)	aw 2
33	IMAX BRK2(SPD2)	SETUP PARAMETERS::CURRENT PROFILE	Current Profile	0.00 to 200.00 % (h)	ax 2
34	FIELD FBKSTOP	RESERVED	Reserved	0 to 1000	ay 4
35	FIELD FFRSTOP	RESERVED	Reserved	0 to 10000	az 4
36	IFFB DELAY	RESERVED	Reserved	0 to 255	b0 4
37	FULL MENUS	MENUS	Menus	Same as tag 4	b1
39	CONFIGURE ENABLE	CONFIGURE DRIVE		Same as tag 4	b3 2
40	SYSTEM IO	RESERVED	Unallocated	0x0000 to 0xFFFF	b4 Output, 4

Parameter Specification Table 10-3

Tag	Name	MMI Menu	CE Block	Range	MN	Notes
41	SETPOINT 4	SETUP PARAMETERS::SPEED LOOP::SETPOINTS	Speed Loop	-105.00 to 105.00 %	b5	
42	AT CURRENT LIMIT	DIAGNOSTICS	Current Loop	0 : FALSE 1 : TRUE	b6	Output
43	MODULUS	SYSTEM::CONFIGURE I/O::DIGITAL OUTPUTS::DIGOUT 1 (B5)	Digout 1 (B5)	Same as tag 42	b7	
44	MODULUS	SYSTEM::CONFIGURE I/O::DIGITAL OUTPUTS::DIGOUT 2 (B6)	Digout 2 (B6)	Same as tag 42	b8	
45	MODULUS	SYSTEM::CONFIGURE I/O::DIGITAL OUTPUTS::DIGOUT 3 (B7)	Digout 3 (B7)	Same as tag 42	b9	
46	ILOOP SUSPEND	RESERVED	Current Loop	Same as tag 42	ba	Output, 4
47	SPEED FBK SELECT	CONFIGURE DRIVE	Speed Loop	0 : ARM VOLTS FBK 1 : ANALOG TACH 2 : ENCODER 3 : ENCODER/ANALOG	bb	2
48	NEG. I CLAMP	SETUP PARAMETERS::CURRENT LOOP	Current Loop	-100.00 to 100.00 %	bc	
49	ENCODER SIGN	CONFIGURE DRIVE	Speed Loop	Same as tag 8	bd	2
50	ANIN 1 (A2)	DIAGNOSTICS	Analog Input 1	xxx.xx VOLTS	be	Output
51	ANIN 2 (A3)	DIAGNOSTICS	Analog Input 2	xxx.xx VOLTS	bf	Output
52	ANIN 3 (A4)	DIAGNOSTICS	Analog Input 3	xxx.xx VOLTS	bg	Output
53	ANIN 4 (A5)	DIAGNOSTICS	Analog Input 4	xxx.xx VOLTS	bh	Output
54	ANIN 5 (A6)	DIAGNOSTICS	Analog Input 5	xxx.xx VOLTS	bi	Output
55	ANOUT 1 (A7)	DIAGNOSTICS	Analog Output 1	xxx.xx VOLTS (h)	bj	Output
56	ANOUT 2 (A8)	DIAGNOSTICS	Analog Output 2	xxx.xx VOLTS (h)	bk	Output
57	TERMINAL VOLTS	DIAGNOSTICS	Calibration	xxx.xx % (h)	bl	Output
58	UNFIL.TACH INPUT	DIAGNOSTICS	Calibration	xxx.xx % (h)	bm	Output
59	UNFIL.ENCODER RPM	DIAGNOSTICS	Calibration	xxxxx RPM	bn	Output
60	BACK EMF	DIAGNOSTICS	Calibration	xxx.xx % (h)	bo	Output
61	ACTUAL NEG I LIM	DIAGNOSTICS	Diagnostics	xxx.xx % (h)	bp	Output
62	UNFIL.SPD.FBK	DIAGNOSTICS	Speed Loop	xxx.xx %	bq	Output
63	SPEED SETPOINT	DIAGNOSTICS	Speed Loop	xxx.xx %	br	Output
64	UNFIL.SPD.ERROR	DIAGNOSTICS	Speed Loop	xxx.xx %	bs	Output
65	IaFbk UNFILTERED	DIAGNOSTICS	Current Loop	xxx.xx % (h)	bt	Output
66	IaDmd UNFILTERED	DIAGNOSTICS	Current Loop	xxx.xx % (h)	bu	Output
67	ACTUAL POS I LIM	DIAGNOSTICS	Diagnostics	xxx.xx % (h)	bv	Output
68	START (C3)	DIAGNOSTICS	Aux I/O	Same as tag 18	bw	Output
69	DIGITAL INPUT C4	DIAGNOSTICS	Aux I/O	Same as tag 18	bx	Output
70	DIGITAL INPUT C5	DIAGNOSTICS	Aux I/O	Same as tag 18	by	Output
71	DIGIN 1 (C6)	DIAGNOSTICS	Digital Input 1	Same as tag 18	bz	Output
72	DIGIN 2 (C7)	DIAGNOSTICS	Digital Input 2	Same as tag 18	c0	Output
73	DIGIN 3 (C8)	DIAGNOSTICS	Digital Input 3	Same as tag 18	c1	Output
74	DIGOUT 1 (B5)	DIAGNOSTICS	Digout 1 (B5)	Same as tag 18	c2	Output
75	DIGOUT 2 (B6)	DIAGNOSTICS	Digout 2 (B6)	Same as tag 18	c3	Output
76	DIGOUT 3 (B7)	DIAGNOSTICS	Digout 3 (B7)	Same as tag 18	c4	Output
77	AT ZERO SPEED	DIAGNOSTICS	Standstill	Same as tag 42	c5	Output
78	AT ZERO SETPOINT	DIAGNOSTICS	Standstill	Same as tag 42	c6	Output
79	AT STANDSTILL	DIAGNOSTICS	Standstill	Same as tag 42	c7	Output
80	PROGRAM STOP	DIAGNOSTICS	Stop Rates	Same as tag 42	c8	Output
81	SPEED FBK ALARM	SETUP PARAMETERS::INHIBIT ALARMS	Alarms	Same as tag 19	c9	
82	DRIVE START	DIAGNOSTICS	Diagnostics	Same as tag 18	ca	Output
83	CONTACTOR CLOSED	DIAGNOSTICS	Unallocated	Same as tag 18	cb	Output

10-4 Parameter Specification Table

Tag	Name	MMI Menu	CE Block	Range	MN	Notes
84	DRIVE ENABLE	DIAGNOSTICS	Diagnostics	Same as tag 4	cc	Output
85	RAMP OUTPUT	DIAGNOSTICS	Ramps	xxx.xx %	cd	Output
86	SPT SUM OUTPUT	DIAGNOSTICS	Setpoint Sum 1	xxx.xx %	ce	Output
87	POS. I CLAMP	DIAGNOSTICS	Diagnostics	xxx.xx % (h)	cf	Output
88	NEG. I CLAMP	DIAGNOSTICS	Diagnostics	xxx.xx % (h)	cg	Output
89	SPEED DEMAND	DIAGNOSTICS	Stop Rates	xxx.xx %	ch	Output
90	BIPOLAR CLAMPS	SETUP PARAMETERS::CURRENT LOOP	Current Loop	Same as tag 4	ci	
91	PROG STOP I LIM	SETUP PARAMETERS::STOP RATES	Stop Rates	0.00 to 200.00 %	cj	
92	ENCODER ALARM	SETUP PARAMETERS::INHIBIT ALARMS	Alarms	Same as tag 19	ck	
93	IMAX BRK1 (SPD1)	SETUP PARAMETERS::CURRENT PROFILE	Current Profile	0.00 to 200.00 % (h)	cl	2
94	AUX DIGOUT 1	SETUP PARAMETERS::AUX I/O	Aux I/O	Same as tag 18	cm	
95	AUX DIGOUT 2	SETUP PARAMETERS::AUX I/O	Aux I/O	Same as tag 18	cn	
96	AUX DIGOUT 3	SETUP PARAMETERS::AUX I/O	Aux I/O	Same as tag 18	co	
97	SOURCE TAG	SYSTEM::CONFIGURE I/O::DIGITAL OUTPUTS::DIGOUT 1 (B5)	Digout 1 (B5)	0 to 549	cp	2, 3
98	SOURCE TAG	SYSTEM::CONFIGURE I/O::DIGITAL OUTPUTS::DIGOUT 2 (B6)	Digout 2 (B6)	0 to 549	cq	2, 3
99	SOURCE TAG	SYSTEM::CONFIGURE I/O::DIGITAL OUTPUTS::DIGOUT 3 (B7)	Digout 3 (B7)	0 to 549	cr	2, 3
100	INPUT 1	SETUP PARAMETERS::SETPOINT SUM 1	Setpoint Sum 1	-200.00 to 200.00 %	cs	
101	MIN BS DEAD TIME	RESERVED	Reserved	1 to 6000	ct	4
102	DESTINATION TAG	SYSTEM::CONFIGURE I/O::DIGITAL INPUTS::DIGIN 1 (C6)	Digital Input 1	0 to 549	cu	2, 3
103	VALUE FOR TRUE	SYSTEM::CONFIGURE I/O::DIGITAL INPUTS::DIGIN 1 (C6)	Digital Input 1	-300.00 to 300.00 %	cv	
104	VALUE FOR FALSE	SYSTEM::CONFIGURE I/O::DIGITAL INPUTS::DIGIN 1 (C6)	Digital Input 1	-300.00 to 300.00 %	cw	
105	DESTINATION TAG	SYSTEM::CONFIGURE I/O::DIGITAL INPUTS::DIGIN 2 (C7)	Digital Input 2	0 to 549	cx	2, 3
106	VALUE FOR TRUE	SYSTEM::CONFIGURE I/O::DIGITAL INPUTS::DIGIN 2 (C7)	Digital Input 2	-300.00 to 300.00 %	cy	
107	VALUE FOR FALSE	SYSTEM::CONFIGURE I/O::DIGITAL INPUTS::DIGIN 2 (C7)	Digital Input 2	-300.00 to 300.00 %	cz	
108	DESTINATION TAG	SYSTEM::CONFIGURE I/O::DIGITAL INPUTS::DIGIN 3 (C8)	Digital Input 3	0 to 549	d0	2, 3
109	VALUE FOR TRUE	SYSTEM::CONFIGURE I/O::DIGITAL INPUTS::DIGIN 3 (C8)	Digital Input 3	-300.00 to 300.00 %	d1	
110	VALUE FOR FALSE	SYSTEM::CONFIGURE I/O::DIGITAL INPUTS::DIGIN 3 (C8)	Digital Input 3	-300.00 to 300.00 %	d2	
111	5703 RCV ERROR	SETUP PARAMETERS::INHIBIT ALARMS	Alarms	Same as tag 19	d3	
112	STALL TRIP	ALARM STATUS	Alarms	0 : OK 1 : FAILED	d4	Output
113	RAMPING	DIAGNOSTICS	Ramps	Same as tag 42	d5	Output

Parameter Specification Table 10-5

Tag	Name	MMI Menu	CE Block	Range	MN	Notes
114	SEQ STATE	RESERVED	Reserved	0 : SEQ DELAY STOP 1 : SEQ INIT 2 : SEQ HOLD 3 : SEQ STANDBY 4 : SEQ PRE READY 5 : SEQ READY 6 : SEQ AUTOTUNING 7 : SEQ RUN 8 : SEQ AT ZERO SPD. 9 : SEQ QUENCH 10 : SEQ PROGRAM STOP 11 : SEQ STOP 12 : SEQ COAST STOP 13 : SEQ ERROR 14 : ENGLISHNov 11 1999 15 : ENGLISHNov 11 1999	d6	Output, 4
115	HEALTH WORD	ALARM STATUS	Alarms	0x0000 to 0xFFFF	d7	Output
116	HEALTH STORE	ALARM STATUS	Alarms	0x0000 to 0xFFFF	d8	Output
117	HEALTH INHIBIT	RESERVED	Unallocated	0x0000 to 0xFFFF	d9	4
118	RAMP HOLD	SETUP PARAMETERS::RAMPS	Ramps	Same as tag 18	da	
119	I DMD. ISOLATE	SETUP PARAMETERS::CURRENT LOOP	Current Loop	Same as tag 4	db	
120	ENTER PASSWORD	PASSWORD		0x0000 to 0xFFFF	dc	1
121	CHANGE PASSWORD	PASSWORD		0x0000 to 0xFFFF	dd	
122	HEALTH LED	DIAGNOSTICS	Alarms	Same as tag 42	de	Output
123	PEEK DATA	SYSTEM::PEEK		0x0000 to 0xFFFF	df	
124	PEEK SCALE	SYSTEM::PEEK		-300.00 to 300.00	dg	
125	READY	DIAGNOSTICS	Alarms	Same as tag 42	dh	Output
126	MIN SPEED	SETUP PARAMETERS::RAMPS	Ramps	0.00 to 100.00 %	di	
128	ANOUT 1	SETUP PARAMETERS::AUX I/O	Aux I/O	-100.00 to 100.00 %	dk	
129	ANOUT 2	SETUP PARAMETERS::AUX I/O	Aux I/O	-100.00 to 100.00 %	dl	
130	MODE	SERIAL LINKS::SYSTEM PORT (P3)::P3 SETUP	System Port P3	0 : DISABLED 1 : 5703 MASTER 2 : 5703 SLAVE 3 : CELite (EIASCII)	dm	
131	DEADBAND WIDTH	SETUP PARAMETERS::SETPOINT SUM 1	Setpoint Sum 1	0.00 to 100.00 % (h)	dn	
132	SETPT. RATIO	SERIAL LINKS::SYSTEM PORT (P3)::P3 SETUP::5703 SUPPORT	5703	-3.0000 to 3.0000	do	
133	SETPT. SIGN	SERIAL LINKS::SYSTEM PORT (P3)::P3 SETUP::5703 SUPPORT	5703	Same as tag 8	dp	
134	SOURCE TAG	SYSTEM::CONFIGURE I/O::CONFIGURE 5703	5703	0 to 549	dq	2, 3
135	DESTINATION TAG	SYSTEM::CONFIGURE I/O::CONFIGURE 5703	Scaled 5703 Input	0 to 549	dr	2, 3
136	FEED FORWARD	SETUP PARAMETERS::CURRENT LOOP	Current Loop	0.10 to 50.00	ds	4
137	DISCONTINUOUS	SETUP PARAMETERS::CURRENT LOOP	Current Loop	0.00 to 200.00 %	dt	
154	II	RESERVED	Reserved	0x0000 to 0xFFFF	ea	Output, 4
155	VERSION NUMBER	SERIAL LINKS::SYSTEM PORT (P3)	Unallocated	0x0000 to 0xFFFF	eb	Output
158	OP STATION ERROR	RESERVED	Op Station	0x0000 to 0xFFFF	ee	Output, 1, 4
161	AUX START	SETUP PARAMETERS::AUX I/O	Aux I/O	Same as tag 18	eh	
162	MIN MMI CYCLE TM	RESERVED	Reserved	0x000A to 0x1388	ei	4
163	ILOOP PI MODE	RESERVED	Reserved	0x0000 to 0x0002	ej	2, 4
164	TOGGLE PERIOD	RESERVED	Reserved	0x0000 to 0xFFFF	ek	4
165	TOGGLE REF 1	RESERVED	Reserved	-300.00 to 300.00 %	el	4
166	SEL. INT/CUR/SPD	RESERVED	Reserved	0x0000 to 0x0004	em	2, 4
167	TOGGLE REF 2	RESERVED	Reserved	-300.00 to 300.00 %	en	4
168	AUX ENABLE	SETUP PARAMETERS::AUX I/O	Aux I/O	Same as tag 18	eo	

10-6 Parameter Specification Table

Tag	Name	MMI Menu	CE Block	Range	MN	Notes
169	FIELD ENABLED	DIAGNOSTICS	Field Control	Same as tag 4	ep	Output
170	FIELD ENABLE	SETUP PARAMETERS::FIELD CONTROL	Field Control	Same as tag 4	eq	2
171	SETPOINT	SETUP PARAMETERS::FIELD CONTROL::FLD.CURRENT VARS	Field Control	0.00 to 100.00 %	er	
172	INT. GAIN	SETUP PARAMETERS::FIELD CONTROL::FLD.CURRENT VARS	Field Control	0.00 to 100.00	es	
173	PROP. GAIN	SETUP PARAMETERS::FIELD CONTROL::FLD.CURRENT VARS	Field Control	0.00 to 100.00	et	
174	FLD. WEAK ENABLE	SETUP PARAMETERS::FIELD CONTROL::FLD.CURRENT VARS::FLD.WEAK VARS	Field Control	Same as tag 4	eu	2
175	EMF LEAD	SETUP PARAMETERS::FIELD CONTROL::FLD.CURRENT VARS::FLD.WEAK VARS	Field Control	0.10 to 50.00	ev	
176	EMF LAG	SETUP PARAMETERS::FIELD CONTROL::FLD.CURRENT VARS::FLD.WEAK VARS	Field Control	0.00 to 200.00	ew	
177	EMF GAIN	SETUP PARAMETERS::FIELD CONTROL::FLD.CURRENT VARS::FLD.WEAK VARS	Field Control	0.00 to 100.00	ex	
178	MAX VOLTS	SETUP PARAMETERS::FIELD CONTROL::FLD.CURRENT VARS::FLD.WEAK VARS	Field Control	0.00 to 100.00 %	ey	
179	MIN FLD.CURRENT	SETUP PARAMETERS::FIELD CONTROL::FLD.CURRENT VARS::FLD.WEAK VARS	Field Control	0.00 to 100.00 %	ez	2
180	SPDFBK ALM LEVEL	SETUP PARAMETERS::CALIBRATION	Calibration	0.00 to 100.00 % (h)	f0	
181	RAW FIELD FBK	DIAGNOSTICS	Calibration	xxx.xx %	f1	Output
182	FIELD I CAL.	SETUP PARAMETERS::CALIBRATION	Calibration	0.9800 to 1.1000	f2	
183	FIELD DEMAND	DIAGNOSTICS	Field Control	xxx.xx %	f3	Output
184	FLD.FIRING ANGLE	DIAGNOSTICS	Field Control	xxx.xx DEG	f4	Output
185	FLD.QUENCH DELAY	SETUP PARAMETERS::FIELD CONTROL	Field Control	0.0 to 600.0 SECS	f5	
186	FLD. QUENCH MODE	SETUP PARAMETERS::FIELD CONTROL	Field Control	0 : QUENCH 1 : STANDBY	f6	
187	RAW INPUT	SERIAL LINKS::SYSTEM PORT (P3)::P3 SETUP::5703 SUPPORT	5703	xxx.xx %	f7	Output
188	OVER SPEED LEVEL	SETUP PARAMETERS::CALIBRATION	Calibration	0.00 to 200.00 %	f8	4
189	SCALED INPUT	SERIAL LINKS::SYSTEM PORT (P3)::P3 SETUP::5703 SUPPORT	5703	xxx.xx %	f9	Output, 2
190	PEAK HW SLOPE	RESERVED	Reserved	-32768 to 32767	fa	2, 4
191	BEMF FBK LEAD	SETUP PARAMETERS::FIELD CONTROL::FLD.CURRENT VARS::FLD.WEAK VARS	Field Control	10 to 5000	fb	
192	BEMF FBK LAG	SETUP PARAMETERS::FIELD CONTROL::FLD.CURRENT VARS::FLD.WEAK VARS	Field Control	10 to 5000	fc	
193	TICK LENGTH	RESERVED	Reserved	xxxxx	fd	Output, 4
194	DISC ADAPT POT	RESERVED	Reserved	0 to 10000	fe	4
195	THRESHOLD (>)	SYSTEM::CONFIGURE I/O::DIGITAL OUTPUTS::DIGOUT 1 (B5)	Digout 1 (B5)	-300.00 to 300.00 %	ff	2
196	THRESHOLD (>)	SYSTEM::CONFIGURE I/O::DIGITAL OUTPUTS::DIGOUT 2 (B6)	Digout 2 (B6)	-300.00 to 300.00 %	fg	2
197	THRESHOLD (>)	SYSTEM::CONFIGURE I/O::DIGITAL OUTPUTS::DIGOUT 3 (B7)	Digout 3 (B7)	-300.00 to 300.00 %	fh	2

Parameter Specification Table 10-7

Tag	Name	MMI Menu	CE Block	Range	MN	Notes
198	P3 BAUD RATE	SERIAL LINKS::SYSTEM PORT (P3)::P3 SETUP		0 : 300 1 : 600 2 : 1200 3 : 2400 4 : 4800 5 : 9600 6 : 19200	fi	2
199	DELAY	SETUP PARAMETERS::INVERSE TIME	Inverse Time	0.1 to 600.0 SECS	fj	2, 4
200	RATE	SETUP PARAMETERS::INVERSE TIME	Inverse Time	0.1 to 600.0 SECS	fk	2, 4
201	REGEN MODE	SETUP PARAMETERS::CURRENT LOOP	Current Loop	0 : 2Q (NON-REGEN) 1 : 4Q (REGEN)	fl	2
202	INT. DEFEAT	SETUP PARAMETERS::SPEED LOOP	Speed Loop	Same as tag 18	fm	
203	INVERSE TIME O/P	DIAGNOSTICS	Inverse Time	xxx.xx %	fn	Output, 2, 4
204	AIMING POINT	SETUP PARAMETERS::INVERSE TIME	Inverse Time	0.00 to 103.00 %	fo	2, 4
205	dl/dt	RESERVED	Reserved	0.00 to 200.00 %	fp	4
206	ENCODER	DIAGNOSTICS	Diagnostics	xxxxx RPM	fq	Output
207	SPEED FEEDBACK	DIAGNOSTICS	Diagnostics	xxx.xx %	fr	Output
208	RATIO 0	SETUP PARAMETERS::SETPOINT SUM 1	Setpoint Sum 1	-3.0000 to 3.0000	fs	
209	FLD.CTRL MODE	CONFIGURE DRIVE	Field Control	0 : VOLTAGE CONTROL 1 : CURRENT CONTROL	ft	2
210	FLD.VOLTS RATIO	CONFIGURE DRIVE	Field Control	0.00 to 100.00 % (h)	fu	
211	HEALTH INHIBIT	RESERVED	Reserved	0x0000 to 0xFFFF	fv	2, 4
212	OPERATING MODE	DIAGNOSTICS	Jog/Slack	0 : STOP 1 : STOP 2 : JOG SP. 1 3 : JOG SP. 2 4 : RUN 5 : TAKE UP SP. 1 6 : TAKE UP SP. 2 7 : CRAWL	fw	Output
213	ZERO CUR OFFSET	RESERVED	Reserved	0x0000 to 0xFFFF	fx	Output, 4
214	ZCD THRESHOLD	RESERVED	Reserved	0x0000 to 0xFFFF	fy	4
215	G&L POWER METER	RESERVED	Unallocated	xxx.xx %	fz	Output, 4
216	PROG STOP LIMIT	SETUP PARAMETERS::STOP RATES	Stop Rates	0.0 to 600.0 SECS	g0	
217	STOP LIMIT	SETUP PARAMETERS::STOP RATES	Stop Rates	0.0 to 600.0 SECS	g1	
218	JOG SPEED 1	SETUP PARAMETERS::JOG/SLACK	Jog/Slack	-100.00 to 100.00 %	g2	
219	JOG SPEED 2	SETUP PARAMETERS::JOG/SLACK	Jog/Slack	-100.00 to 100.00 %	g3	
221	MMI FILTER T.C.	RESERVED	Reserved	0 to 20000	g5	4
222	PRED STEP	RESERVED	Reserved	0x0000 to 0xFFFF	g6	2, 4
223	SCAN THRESHOLD	RESERVED	Reserved	0x0000 to 0xFFFF	g7	2, 4
224	STALL TRIP DELAY	SETUP PARAMETERS::CALIBRATION	Calibration	0.1 to 600.0 SECS	g8	
225	CRAWL SPEED	SETUP PARAMETERS::JOG/SLACK	Jog/Slack	-100.00 to 100.00 %	g9	
226	PEAK HW OFFSET	RESERVED	Reserved	0 to 20000	ga	2, 4
227	AUX JOG	SETUP PARAMETERS::AUX I/O	Aux I/O	Same as tag 18	gb	
228	MODE	SETUP PARAMETERS::JOG/SLACK	Jog/Slack	Same as tag 42	gc	
230	CALIBRATION	SYSTEM::CONFIGURE I/O::ANALOG INPUTS::ANIN 1 (A2)	Analog Input 1	-3.0000 to 3.0000	ge	
231	MAX VALUE	SYSTEM::CONFIGURE I/O::ANALOG INPUTS::ANIN 1 (A2)	Analog Input 1	-300.00 to 300.00 %	gf	
232	MIN VALUE	SYSTEM::CONFIGURE I/O::ANALOG INPUTS::ANIN 1 (A2)	Analog Input 1	-300.00 to 300.00 %	gg	
233	CALIBRATION	SYSTEM::CONFIGURE I/O::ANALOG INPUTS::ANIN 2 (A3)	Analog Input 2	-3.0000 to 3.0000	gh	
234	MAX VALUE	SYSTEM::CONFIGURE I/O::ANALOG INPUTS::ANIN 2 (A3)	Analog Input 2	-300.00 to 300.00 %	gi	

10-8 Parameter Specification Table

Tag	Name	MMI Menu	CE Block	Range	MN Notes
235	MIN VALUE	SYSTEM::CONFIGURE I/O::ANALOG INPUTS::ANIN 2 (A3)	Analog Input 2	-300.00 to 300.00 %	gj
236	CALIBRATION	SYSTEM::CONFIGURE I/O::ANALOG INPUTS::ANIN 3 (A4)	Analog Input 3	-3.0000 to 3.0000	gk
237	MAX VALUE	SYSTEM::CONFIGURE I/O::ANALOG INPUTS::ANIN 3 (A4)	Analog Input 3	-300.00 to 300.00 %	gl
238	MIN VALUE	SYSTEM::CONFIGURE I/O::ANALOG INPUTS::ANIN 3 (A4)	Analog Input 3	-300.00 to 300.00 %	gm
239	CALIBRATION	SYSTEM::CONFIGURE I/O::ANALOG INPUTS::ANIN 4 (A5)	Analog Input 4	-3.0000 to 3.0000	gn
240	MAX VALUE	SYSTEM::CONFIGURE I/O::ANALOG INPUTS::ANIN 4 (A5)	Analog Input 4	-300.00 to 300.00 %	go
241	MIN VALUE	SYSTEM::CONFIGURE I/O::ANALOG INPUTS::ANIN 4 (A5)	Analog Input 4	-300.00 to 300.00 %	gp
242	CALIBRATION	SYSTEM::CONFIGURE I/O::ANALOG INPUTS::ANIN 5 (A6)	Analog Input 5	-3.0000 to 3.0000	gq
243	MAX VALUE	SYSTEM::CONFIGURE I/O::ANALOG INPUTS::ANIN 5 (A6)	Analog Input 5	-300.00 to 300.00 %	gr
244	MIN VALUE	SYSTEM::CONFIGURE I/O::ANALOG INPUTS::ANIN 5 (A6)	Analog Input 5	-300.00 to 300.00 %	gs
245	% TO GET 10V	SYSTEM::CONFIGURE I/O::ANALOG OUTPUTS::ANOUT 1 (A7)	Analog Output 1	-300.00 to 300.00 %	gt
246	DESTINATION TAG	SYSTEM::CONFIGURE I/O::ANALOG INPUTS::ANIN 1 (A2)	Analog Input 1	0 to 549	gu 2, 3
247	DESTINATION TAG	SYSTEM::CONFIGURE I/O::ANALOG INPUTS::ANIN 5 (A6)	Analog Input 5	0 to 549	gv 2, 3
248	% TO GET 10V	SYSTEM::CONFIGURE I/O::ANALOG OUTPUTS::ANOUT 2 (A8)	Analog Output 2	-300.00 to 300.00 %	gw
249	DESTINATION TAG	SYSTEM::CONFIGURE I/O::ANALOG INPUTS::ANIN 3 (A4)	Analog Input 3	0 to 549	gx 2, 3
250	DESTINATION TAG	SYSTEM::CONFIGURE I/O::ANALOG INPUTS::ANIN 4 (A5)	Analog Input 4	0 to 549	gy 2, 3
251	SOURCE TAG	SYSTEM::CONFIGURE I/O::ANALOG OUTPUTS::ANOUT 1 (A7)	Analog Output 1	0 to 549	gz 2, 3
252	SOURCE TAG	SYSTEM::CONFIGURE I/O::ANALOG OUTPUTS::ANOUT 2 (A8)	Analog Output 2	0 to 549	h0 2, 3
253	TAKE UP 1	SETUP PARAMETERS::JOG/SLACK	Jog/Slack	-100.00 to 100.00 %	h1
254	TAKE UP 2	SETUP PARAMETERS::JOG/SLACK	Jog/Slack	-100.00 to 100.00 %	h2
255	RESET VALUE	SETUP PARAMETERS::RAISE/LOWER	Raise/Lower	-300.00 to 300.00 %	h3
256	INCREASE RATE	SETUP PARAMETERS::RAISE/LOWER	Raise/Lower	0.1 to 600.0 SECS	h4
257	DECREASE RATE	SETUP PARAMETERS::RAISE/LOWER	Raise/Lower	0.1 to 600.0 SECS	h5
258	MIN VALUE	SETUP PARAMETERS::RAISE/LOWER	Raise/Lower	-300.00 to 300.00 %	h6
259	MAX VALUE	SETUP PARAMETERS::RAISE/LOWER	Raise/Lower	-300.00 to 300.00 %	h7
260	RAISE/LOWER DEST	SYSTEM::CONFIGURE I/O::BLOCK DIAGRAM	Raise/Lower Output	0 to 549	h8
261	RAISE INPUT	SETUP PARAMETERS::RAISE/LOWER	Raise/Lower	Same as tag 42	h9
262	LOWER INPUT	SETUP PARAMETERS::RAISE/LOWER	Raise/Lower	Same as tag 42	ha
263	STALL THRESHOLD	SETUP PARAMETERS::CALIBRATION	Calibration	0.00 to 200.00 %	hb
264	RAISE/LOWER O/P	DIAGNOSTICS	Raise/Lower	xxx.xx %	hc Output
265	ANALOG IP OFFSET	RESERVED	Reserved	-30000 to 30000	hd 4
266	% S-RAMP	SETUP PARAMETERS::RAMPS	Ramps	0.00 to 100.00 %	he
267	POSITION COUNT	RESERVED	Calibration	0x0000 to 0xFFFF	hf 4
268	MODE	SETUP PARAMETERS::SPEED LOOP::ADVANCED::ADAPTION	Advanced	0 to 3	hg
269	SPD BRK1 (LOW)	SETUP PARAMETERS::SPEED LOOP::ADVANCED::ADAPTION	Advanced	0.00 to 100.00 %	hh

Parameter Specification Table 10-9

Tag	Name	MMI Menu	CE Block	Range	MN	Notes
270	SPD BRK2 (HIGH)	SETUP PARAMETERS::SPEED LOOP::ADVANCED::ADAPTION	Advanced	0.00 to 100.00 %	hi	
271	PROP. GAIN	SETUP PARAMETERS::SPEED LOOP::ADVANCED::ADAPTION	Advanced	0.00 to 200.00	hj	
272	SPD.INT.TIME	SETUP PARAMETERS::SPEED LOOP::ADVANCED::ADAPTION	Advanced	0.001 to 30.000 SECS	hk	
273	POS. LOOP P GAIN	SETUP PARAMETERS::SPEED LOOP::ADVANCED	Advanced	-200.00 to 200.00 %	hl	4
274	I GAIN IN RAMP	SETUP PARAMETERS::SPEED LOOP::ADVANCED	Advanced	0.0000 to 2.0000	hm	
275	POSITION DIVIDER	RESERVED	Calibration	1 to 30000	hn	4
276	PLL PROP	RESERVED	Reserved	0 to 20000	ho	4
277	PLL INT	RESERVED	Reserved	0 to 20000	hp	4
278	PLL ERROR	RESERVED	Unallocated	xxxx	hq	Output, 4
279	ARM ENDSTOP	RESERVED	Reserved	0 to 20000	hr	2, 4
280	HF C/O DISC GAIN	RESERVED	Reserved	0 to 10000	hs	4
281	HF C/O FILTER TC	RESERVED	Reserved	0 to 20000	ht	4
282	BEMF THRESHOLD	RESERVED	Reserved	0 to 20000	hu	4
283	SCAN TC	RESERVED	Reserved	0 to 20000	hv	4
284	ZERO SPD. LEVEL	SETUP PARAMETERS::SPEED LOOP::ADVANCED::ZERO SPD. QUENCH	Advanced	0.00 to 200.00 %	hw	
285	ZERO IAD LEVEL	SETUP PARAMETERS::SPEED LOOP::ADVANCED::ZERO SPD. QUENCH	Advanced	0.00 to 200.00 %	hx	
286	RAMPING THRESH.	SETUP PARAMETERS::RAMPS	Ramps	0.00 to 100.00 %	hy	
287	AUTO RESET	SETUP PARAMETERS::RAMPS	Ramps	Same as tag 4	hz	
288	EXTERNAL RESET	SETUP PARAMETERS::RAMPS	Ramps	Same as tag 4	i0	
289	SETPOINT 1	SETUP PARAMETERS::SPEED LOOP::SETPOINTS	Speed Loop	-105.00 to 105.00 %	i1	
290	SETPOINT 2 (A3)	SETUP PARAMETERS::SPEED LOOP::SETPOINTS	Speed Loop	xxx.xx %	i2	Output
291	SETPOINT 3	SETUP PARAMETERS::SPEED LOOP::SETPOINTS	Speed Loop	-105.00 to 105.00 %	i3	
292	SIGN 0	SETUP PARAMETERS::SETPOINT SUM 1	Setpoint Sum 1	Same as tag 8	i4	
293	RAMP O/P DEST	SYSTEM::CONFIGURE I/O::BLOCK DIAGRAM	Ramp Output	0 to 549	i5	2, 3
294	SPT SUM 1 DEST	SYSTEM::CONFIGURE I/O::BLOCK DIAGRAM	Setpoint Sum 1 Output	0 to 549	i6	2, 3
295	FILTER INPUT	RESERVED	User Filter	-300.00 to 300.00 %	i7	4
296	FILTER OUTPUT	RESERVED	User Filter	xxx.xx %	i8	Output, 4
297	SPEED ERROR	DIAGNOSTICS	Diagnostics	xxx.xx %	i9	Output
298	CURRENT FEEDBACK	DIAGNOSTICS	Diagnostics	xxx.xx %	ia	Output
299	CURRENT DEMAND	DIAGNOSTICS	Diagnostics	xxx.xx %	ib	Output
300	FIELD I FBK.	DIAGNOSTICS	Diagnostics	xxx.xx %	ic	Output
301	POS. I CLAMP	SETUP PARAMETERS::CURRENT LOOP	Current Loop	-100.00 to 100.00 %	id	
302	CONTACTOR DELAY	SETUP PARAMETERS::STOP RATES	Stop Rates	0.1 to 600.0 SECS	ie	
304	LANGUAGE	Not on MMI	Menus	0 : ENGLISH 1 : Other	ig	2
305	TRIP RESET	SETUP PARAMETERS::INHIBIT ALARMS	Alarms	Same as tag 42	ih	
306	SOURCE TAG	SETUP PARAMETERS::STANDSTILL	Standstill	0 to 549	ii	2, 3, 4
307	EXTERNAL RESET	SETUP PARAMETERS::RAISE/LOWER	Raise/Lower	Same as tag 42	ij	
308	TACH INPUT	DIAGNOSTICS	Diagnostics	xxx.xx % (h)	ik	Output
309	INPUT 0	SETUP PARAMETERS::SETPOINT SUM 1	Setpoint Sum 1	-200.00 to 200.00 %	il	

10-10 Parameter Specification Table

Tag	Name	MMI Menu	CE Block	Range	MN	Notes
310	AUTOCAL	RESERVED	Reserved	Same as tag 4	im	4
311	IAINST OFFSET	RESERVED	Reserved	xxxx	in	Output, 4
312	PNO 112	SERIAL LINKS::PNO CONFIG	PNO 112	0 to 549	io	
313	PNO 113	SERIAL LINKS::PNO CONFIG	PNO 113	0 to 549	ip	
314	PNO 114	SERIAL LINKS::PNO CONFIG	PNO 114	0 to 549	iq	
315	PNO 115	SERIAL LINKS::PNO CONFIG	PNO 115	0 to 549	ir	
316	PNO 116	SERIAL LINKS::PNO CONFIG	PNO 116	0 to 549	is	
317	PNO 117	SERIAL LINKS::PNO CONFIG	PNO 117	0 to 549	it	
318	PNO 118	SERIAL LINKS::PNO CONFIG	PNO 118	0 to 549	iu	
319	PNO 119	SERIAL LINKS::PNO CONFIG	PNO 119	0 to 549	iv	
320	PNO 120	SERIAL LINKS::PNO CONFIG	PNO 120	0 to 549	iw	
321	PNO 121	SERIAL LINKS::PNO CONFIG	PNO 121	0 to 549	ix	
322	PNO 122	SERIAL LINKS::PNO CONFIG	PNO 122	0 to 549	iy	
323	PNO 123	SERIAL LINKS::PNO CONFIG	PNO 123	0 to 549	iz	
324	PNO 124	SERIAL LINKS::PNO CONFIG	PNO 124	0 to 549	j0	
325	PNO 125	SERIAL LINKS::PNO CONFIG	PNO 125	0 to 549	j1	
326	PNO 126	SERIAL LINKS::PNO CONFIG	PNO 126	0 to 549	j2	
327	PNO 127	SERIAL LINKS::PNO CONFIG	PNO 127	0 to 549	j3	
329	GROUP ID (GID)	SERIAL LINKS::SYSTEM PORT (P3)::P3 SETUP::BISYNCH SUPPORT	System Port P3	0x0000 to 0x0007	j5	
330	UNIT ID (UID)	SERIAL LINKS::SYSTEM PORT (P3)::P3 SETUP::BISYNCH SUPPORT	System Port P3	0x0000 to 0x000F	j6	
332	ERROR REPORT	SERIAL LINKS::SYSTEM PORT (P3)::P3 SETUP::BISYNCH SUPPORT	System Port P3	0x0000 to 0xFFFF	j8	1
335	DISABLE MEAN FBK	RESERVED	Reserved	Same as tag 42	jb	4
336	CHANGEOVER BIAS	RESERVED	Reserved	0x0000 to 0xFFFF	jc	2, 4
337	THERMISTOR STATE	ALARM STATUS	Unallocated	Same as tag 42	jd	Output
339	VALUE 1	SYSTEM::miniLINK	Minilink	-300.00 to 300.00 %	jf	
340	VALUE 2	SYSTEM::miniLINK	Minilink	-300.00 to 300.00 %	ig	
341	VALUE 3	SYSTEM::miniLINK	Minilink	-300.00 to 300.00 %	jh	
342	VALUE 4	SYSTEM::miniLINK	Minilink	-300.00 to 300.00 %	ji	
343	VALUE 5	SYSTEM::miniLINK	Minilink	-300.00 to 300.00 %	jj	
344	VALUE 6	SYSTEM::miniLINK	Minilink	-300.00 to 300.00 %	jk	
345	VALUE 7	SYSTEM::miniLINK	Minilink	-300.00 to 300.00 %	jl	
346	LOGIC 1	SYSTEM::miniLINK	Minilink	Same as tag 18	jm	
347	LOGIC 2	SYSTEM::miniLINK	Minilink	Same as tag 18	jn	
348	LOGIC 3	SYSTEM::miniLINK	Minilink	Same as tag 18	jo	
349	LOGIC 4	SYSTEM::miniLINK	Minilink	Same as tag 18	jp	
350	LOGIC 5	SYSTEM::miniLINK	Minilink	Same as tag 18	jq	
351	LOGIC 6	SYSTEM::miniLINK	Minilink	Same as tag 18	jr	
352	LOGIC 7	SYSTEM::miniLINK	Minilink	Same as tag 18	js	
353	LOGIC 8	SYSTEM::miniLINK	Minilink	Same as tag 18	jt	
354	PARAMETER SAVE	PARAMETER SAVE		0 : UP TO ACTION 1 : REQUESTED	ju	1
355	RAMP RATE	SETUP PARAMETERS::JOG/SLACK	Jog/Slack	0.1 to 600.0 SECS	jv	
357	MAX DEMAND	SETUP PARAMETERS::SPEED LOOP::SETPOINTS	Speed Loop	0.00 to 105.00 %	jx	
358	MIN DEMAND	SETUP PARAMETERS::SPEED LOOP::SETPOINTS	Speed Loop	-105.00 to 105.00 %	iy	
359	INVERTED	SYSTEM::CONFIGURE I/O::DIGITAL OUTPUTS::DIGOUT 1 (B5)	Digout 1 (B5)	Same as tag 42	jz	

Parameter Specification Table 10-11

Tag	Name	MMI Menu	CE Block	Range	MN Notes
360	INVERTED	SYSTEM::CONFIGURE I/O::DIGITAL OUTPUTS::DIGOUT 2 (B6)	Digout 2 (B6)	Same as tag 42	k0
361	INVERTED	SYSTEM::CONFIGURE I/O::DIGITAL OUTPUTS::DIGOUT 3 (B7)	Digout 3 (B7)	Same as tag 42	k1
362	MODULUS	SYSTEM::CONFIGURE I/O::ANALOG OUTPUTS::ANOUT 1 (A7)	Analog Output 1	Same as tag 42	k2
363	MODULUS	SYSTEM::CONFIGURE I/O::ANALOG OUTPUTS::ANOUT 2 (A8)	Analog Output 2	Same as tag 42	k3
364	SOURCE TAG	SYSTEM::CONFIGURE I/O::INTERNAL LINKS::LINK 1	Link 1	0 to 549	k4 2, 3
365	DESTINATION TAG	SYSTEM::CONFIGURE I/O::INTERNAL LINKS::LINK 1	Link 1	0 to 549	k5 2, 3
366	SOURCE TAG	SYSTEM::CONFIGURE I/O::INTERNAL LINKS::LINK 2	Link 2	0 to 549	k6 2, 3
367	DESTINATION TAG	SYSTEM::CONFIGURE I/O::INTERNAL LINKS::LINK 2	Link 2	0 to 549	k7 2, 3
368	SOURCE TAG	SYSTEM::CONFIGURE I/O::INTERNAL LINKS::LINK 3	Link 3	0 to 549	k8 2, 3
369	DESTINATION TAG	SYSTEM::CONFIGURE I/O::INTERNAL LINKS::LINK 3	Link 3	0 to 549	k9 2, 3
370	SOURCE TAG	SYSTEM::CONFIGURE I/O::INTERNAL LINKS::LINK 4	Link 4	0 to 549	ka 2, 3
371	DESTINATION TAG	SYSTEM::CONFIGURE I/O::INTERNAL LINKS::LINK 4	Link 4	0 to 549	kb 2, 3
372	R/L DELTA	RESERVED	Unallocated	xxx.xx %	kc Output, 4
373	SYS RAMP DELTA	RESERVED	Unallocated	xxx.xx %	kd Output, 4
374	SYSTEM RESET	DIAGNOSTICS	Unallocated	Same as tag 42	ke Output
375	LIMIT	SETUP PARAMETERS::SETPOINT SUM 1	Setpoint Sum 1	0.00 to 200.00 %	kf
376	DRIVE RUNNING	DIAGNOSTICS	Unallocated	Same as tag 42	kg Output
378	LANG CHECKSUM	Not on MMI		0x0000 to 0xFFFF	ki Output, 1
379	VALUE 8	SYSTEM::miniLINK	Minilink	-300.00 to 300.00 %	kj
380	VALUE 9	SYSTEM::miniLINK	Minilink	-300.00 to 300.00 %	kk
381	VALUE 10	SYSTEM::miniLINK	Minilink	-300.00 to 300.00 %	kl
382	VALUE 11	SYSTEM::miniLINK	Minilink	-300.00 to 300.00 %	km
383	VALUE 12	SYSTEM::miniLINK	Minilink	-300.00 to 300.00 %	kn
384	VALUE 13	SYSTEM::miniLINK	Minilink	-300.00 to 300.00 %	ko
385	VALUE 14	SYSTEM::miniLINK	Minilink	-300.00 to 300.00 %	kp
386	FILTER T.C.	RESERVED	Reserved	0 to 20000	kq 4
387	RAW POS COUNT	RESERVED	Reserved	xxxxx	kr Output, 1, 4
388	SYNC OFFSET	RESERVED	Reserved	-30000 to 30000	ks 4
389	PERCENT RPM	RESERVED	Reserved	xxx.xx %	kt Output, 4
390	SOURCE TAG	SYSTEM::CONFIGURE I/O::INTERNAL LINKS::LINK 11	Link 11	0 to 549	ku 2, 3
391	DESTINATION TAG	SYSTEM::CONFIGURE I/O::INTERNAL LINKS::LINK 11	Link 11	0 to 549	kv 2, 3
392	ADVANCED	SYSTEM::CONFIGURE I/O::INTERNAL LINKS::LINK 11	Link 11	Same as tag 18	kw
393	MODE	SYSTEM::CONFIGURE I/O::INTERNAL LINKS::LINK 11	Link 11	0 : SWITCH 1 : INVERTER 2 : AND 3 : OR 4 : SIGN CHANGER 5 : MODULUS 6 : COMPARATOR	kx
394	AUX.SOURCE	SYSTEM::CONFIGURE I/O::INTERNAL LINKS::LINK 11	Link 11	0 to 549	ky 2, 3

10-12 Parameter Specification Table

Tag	Name	MMI Menu	CE Block	Range	MN	Notes
395	SOURCE TAG	SYSTEM::CONFIGURE I/O::INTERNAL LINKS::LINK 12	Link 12	0 to 549	kz	2, 3
396	DESTINATION TAG	SYSTEM::CONFIGURE I/O::INTERNAL LINKS::LINK 12	Link 12	0 to 549	l0	2, 3
397	ADVANCED	SYSTEM::CONFIGURE I/O::INTERNAL LINKS::LINK 12	Link 12	Same as tag 18	l1	
398	MODE	SYSTEM::CONFIGURE I/O::INTERNAL LINKS::LINK 12	Link 12	Same as tag 393	l2	
399	AUX.SOURCE	SYSTEM::CONFIGURE I/O::INTERNAL LINKS::LINK 12	Link 12	0 to 549	l3	2, 3
400	PID O/P DEST	SYSTEM::CONFIGURE I/O::BLOCK DIAGRAM	PID Output	0 to 549	l4	2, 3
401	DERIVATIVE TC	SETUP PARAMETERS::SPECIAL BLOCKS::PID	PID	0.000 to 10.000 SECS	l5	
402	INT.TIME.CONST	SETUP PARAMETERS::SPECIAL BLOCKS::PID	PID	0.01 to 100.00 SECS	l6	
403	FILTER T.C.	SETUP PARAMETERS::SPECIAL BLOCKS::PID	PID	0.000 to 10.000 SECS	l7	
404	PROP. GAIN	SETUP PARAMETERS::SPECIAL BLOCKS::PID	PID	0.0 to 100.0	l8	
405	POSITIVE LIMIT	SETUP PARAMETERS::SPECIAL BLOCKS::PID	PID	0.00 to 105.00 %	l9	
406	NEGATIVE LIMIT	SETUP PARAMETERS::SPECIAL BLOCKS::PID	PID	-105.00 to 0.00 %	la	
407	O/P SCALER(TRIM)	SETUP PARAMETERS::SPECIAL BLOCKS::PID	PID	-3.0000 to 3.0000	lb	
408	ENABLE	SETUP PARAMETERS::SPECIAL BLOCKS::PID	PID	Same as tag 4	lc	
409	INT. DEFEAT	SETUP PARAMETERS::SPECIAL BLOCKS::PID	PID	Same as tag 18	ld	
410	INPUT 1	SETUP PARAMETERS::SPECIAL BLOCKS::PID	PID	-300.00 to 300.00 %	le	
411	INPUT 2	SETUP PARAMETERS::SPECIAL BLOCKS::PID	PID	-300.00 to 300.00 %	lf	
412	RATIO 1	SETUP PARAMETERS::SPECIAL BLOCKS::PID	PID	-3.0000 to 3.0000	lg	
413	RATIO 2	SETUP PARAMETERS::SPECIAL BLOCKS::PID	PID	-3.0000 to 3.0000	lh	
414	DIVIDER 2	SETUP PARAMETERS::SPECIAL BLOCKS::PID	PID	-3.0000 to 3.0000	li	
415	PID ERROR	DIAGNOSTICS	PID	xxx.xx %	lj	Output
416	PID CLAMPED	DIAGNOSTICS	PID	Same as tag 42	lk	Output
417	PID OUTPUT	DIAGNOSTICS	PID	xxx.xx %	ll	Output
418	DIVIDER 1	SETUP PARAMETERS::SPECIAL BLOCKS::PID	PID	-3.0000 to 3.0000	lm	
419	DIVIDER 1	SETUP PARAMETERS::SETPOINT SUM 1	Setpoint Sum 1	-3.0000 to 3.0000	ln	
420	DIVIDER 0	SETUP PARAMETERS::SETPOINT SUM 1	Setpoint Sum 1	-3.0000 to 3.0000	lo	
421	MAIN CURR. LIMIT	SETUP PARAMETERS::CURRENT LOOP	Current Loop	0.00 to 200.00 %	lp	
422	RESET VALUE	SETUP PARAMETERS::RAMPS	Ramps	-300.00 to 300.00 %	lq	
423	INPUT 2	SETUP PARAMETERS::SETPOINT SUM 1	Setpoint Sum 1	-200.00 to 200.00 %	lr	
424	LINE SPEED	SETUP PARAMETERS::SPECIAL BLOCKS::DIAMETER CALC.	Diameter Calc.	-105.00 to 105.00 %	ls	
425	MIN DIAMETER	SETUP PARAMETERS::SPECIAL BLOCKS::DIAMETER CALC.	Diameter Calc.	0.00 to 100.00 %	lt	
426	MIN SPEED	SETUP PARAMETERS::SPECIAL BLOCKS::DIAMETER CALC.	Diameter Calc.	0.00 to 100.00 %	lu	

Parameter Specification Table 10-13

Tag	Name	MMI Menu	CE Block	Range	MN	Notes
427	DIAMETER	SETUP PARAMETERS::SPECIAL BLOCKS::DIAMETER CALC.	Diameter Calc.	xxx.xx %	lv	Output
428	MOD OF LINE SPD	SETUP PARAMETERS::SPECIAL BLOCKS::DIAMETER CALC.	Diameter Calc.	xxx.xx %	lw	Output
429	MOD OF REEL SPD	SETUP PARAMETERS::SPECIAL BLOCKS::DIAMETER CALC.	Diameter Calc.	xxx.xx %	lx	Output
430	UNFILT DIAMETER	SETUP PARAMETERS::SPECIAL BLOCKS::DIAMETER CALC.	Diameter Calc.	xxx.xx %	ly	Output
431	DIAMETER	SYSTEM::CONFIGURE I/O::BLOCK DIAGRAM	Diameter	0 to 549	lz	2, 3
432	TORQUE DEMAND	SETUP PARAMETERS::SPECIAL BLOCKS::TORQUE CALC.	Torque Calc.	-200.00 to 200.00 %	m0	
433	TENSION ENABLE	SETUP PARAMETERS::SPECIAL BLOCKS::TORQUE CALC.	Torque Calc.	Same as tag 4	m1	
434	OVER WIND	SETUP PARAMETERS::SPECIAL BLOCKS::TORQUE CALC.	Torque Calc.	Same as tag 4	m2	
435	POS. I CLAMP	SYSTEM::CONFIGURE I/O::BLOCK DIAGRAM	Torque Calc.	0 to 549	m3	2, 3
436	NEG. I CLAMP	SYSTEM::CONFIGURE I/O::BLOCK DIAGRAM	Torque Calc.	0 to 549	m4	2, 3
437	REEL SPEED	SETUP PARAMETERS::SPECIAL BLOCKS::DIAMETER CALC.	Diameter Calc.	-105.00 to 105.00 %	m5	
438	TAPER	SETUP PARAMETERS::SPECIAL BLOCKS::TAPER CALC.	Taper Calc.	-100.00 to 100.00 %	m6	
439	TENSION SPT.	SETUP PARAMETERS::SPECIAL BLOCKS::TAPER CALC.	Taper Calc.	0.00 to 100.00 %	m7	
440	TENSION TRIM	SETUP PARAMETERS::SPECIAL BLOCKS::TAPER CALC.	Taper Calc.	-100.00 to 100.00 %	m8	
441	TOT.TENS.DEMAND	SETUP PARAMETERS::SPECIAL BLOCKS::TAPER CALC.	Taper Calc.	xxx.xx %	m9	Output
442	TAPER	SYSTEM::CONFIGURE I/O::BLOCK DIAGRAM	Taper	0 to 549	ma	2, 3
443	INPUT 1	SETUP PARAMETERS::SPECIAL BLOCKS::SETPOINT SUM 2	Setpoint Sum 2	-300.00 to 300.00 %	mb	
444	INPUT 0	SETUP PARAMETERS::SPECIAL BLOCKS::SETPOINT SUM 2	Setpoint Sum 2	-300.00 to 300.00 %	mc	
445	INPUT 2	SETUP PARAMETERS::SPECIAL BLOCKS::SETPOINT SUM 2	Setpoint Sum 2	-300.00 to 300.00 %	md	
446	RATIO 1	SETUP PARAMETERS::SPECIAL BLOCKS::SETPOINT SUM 2	Setpoint Sum 2	-3.0000 to 3.0000	me	
447	RATIO 0	SETUP PARAMETERS::SPECIAL BLOCKS::SETPOINT SUM 2	Setpoint Sum 2	-3.0000 to 3.0000	mf	
448	DIVIDER 0	SETUP PARAMETERS::SPECIAL BLOCKS::SETPOINT SUM 2	Setpoint Sum 2	-3.0000 to 3.0000	mg	
449	LIMIT	SETUP PARAMETERS::SPECIAL BLOCKS::SETPOINT SUM 2	Setpoint Sum 2	0.00 to 200.00 %	mh	
450	SETPOINT SUM 2	SYSTEM::CONFIGURE I/O::BLOCK DIAGRAM	Setpoint Sum 2 Output	0 to 549	mi	2, 3
451	SPT SUM OUTPUT	SETUP PARAMETERS::SPECIAL BLOCKS::SETPOINT SUM 2	Setpoint Sum 2	xxx.xx %	mj	Output
452	TAPERED DEMAND	SETUP PARAMETERS::SPECIAL BLOCKS::TAPER CALC.	Taper Calc.	xxx.xx %	mk	Output
453	RAMP RATE	SETUP PARAMETERS::SPECIAL BLOCKS::DIAMETER CALC.	Diameter Calc.	0.1 to 600.0 SECS	ml	
454	SOURCE TAG	SYSTEM::CONFIGURE I/O::INTERNAL LINKS::LINK 5	Link 5	0 to 549	m m	2, 3
455	DESTINATION TAG	SYSTEM::CONFIGURE I/O::INTERNAL LINKS::LINK 5	Link 5	0 to 549	mn	2, 3

10-14 Parameter Specification Table

Tag	Name	MMI Menu	CE Block	Range	MN	Notes
456	SOURCE TAG	SYSTEM::CONFIGURE I/O::INTERNAL LINKS::LINK 6	Link 6	0 to 549	mo	2, 3
457	DESTINATION TAG	SYSTEM::CONFIGURE I/O::INTERNAL LINKS::LINK 6	Link 6	0 to 549	mp	2, 3
458	SOURCE TAG	SYSTEM::CONFIGURE I/O::INTERNAL LINKS::LINK 7	Link 7	0 to 549	mq	2, 3
459	DESTINATION TAG	SYSTEM::CONFIGURE I/O::INTERNAL LINKS::LINK 7	Link 7	0 to 549	mr	2, 3
460	SOURCE TAG	SYSTEM::CONFIGURE I/O::INTERNAL LINKS::LINK 8	Link 8	0 to 549	ms	2, 3
461	DESTINATION TAG	SYSTEM::CONFIGURE I/O::INTERNAL LINKS::LINK 8	Link 8	0 to 549	mt	2, 3
462	RESET VALUE	SETUP PARAMETERS::SPECIAL BLOCKS::DIAMETER CALC.	Diameter Calc.	0.00 to 100.00 %	mu	
463	EXTERNAL RESET	SETUP PARAMETERS::SPECIAL BLOCKS::DIAMETER CALC.	Diameter Calc.	Same as tag 4	mv	
464	OFFSET	SYSTEM::CONFIGURE I/O::ANALOG OUTPUTS::ANOUT 1 (A7)	Analog Output 1	-100.00 to 100.00 %	mw	
465	OFFSET	SYSTEM::CONFIGURE I/O::ANALOG OUTPUTS::ANOUT 2 (A8)	Analog Output 2	-100.00 to 100.00 %	mx	
466	DIVIDER 1	SETUP PARAMETERS::SPECIAL BLOCKS::SETPOINT SUM 2	Setpoint Sum 2	-3.0000 to 3.0000	my	
467	SOURCE TAG	SYSTEM::CONFIGURE I/O::INTERNAL LINKS::LINK 9	Link 9	0 to 549	mz	2, 3
468	DESTINATION TAG	SYSTEM::CONFIGURE I/O::INTERNAL LINKS::LINK 9	Link 9	0 to 549	n0	2, 3
469	SOURCE TAG	SYSTEM::CONFIGURE I/O::INTERNAL LINKS::LINK 10	Link 10	0 to 549	n1	2, 3
470	DESTINATION TAG	SYSTEM::CONFIGURE I/O::INTERNAL LINKS::LINK 10	Link 10	0 to 549	n2	2, 3
471	STANDBY FIELD	RESERVED	Reserved	0.00 to 100.00 %	n3	4
472	SPEED FBK STATE	ALARM STATUS	Unallocated	Same as tag 42	n4	Output
473	MODE	SETUP PARAMETERS::SPECIAL BLOCKS::PID	PID	0 to 4	n5	
474	MIN PROFILE GAIN	SETUP PARAMETERS::SPECIAL BLOCKS::PID	PID	0.00 to 100.00 %	n6	
475	PROFILED GAIN	SETUP PARAMETERS::SPECIAL BLOCKS::PID	PID	xxxx.x	n7	Output
476	3-PHASE FIELD	RESERVED	Reserved	Same as tag 4	n8	2, 4
477	AUTOTUNE	Not on MMI		Same as tag 18	n9	Output, 2
478	TENS+COMP CALC.	SYSTEM::CONFIGURE I/O::BLOCK DIAGRAM	Tension & Comp	0 to 549	na	2, 3
479	FIX.INERTIA COMP	SETUP PARAMETERS::SPECIAL BLOCKS::TENS+COMP CALC.	Tension & Comp	-300.00 to 300.00 %	nb	
480	VAR.INERTIA COMP	SETUP PARAMETERS::SPECIAL BLOCKS::TENS+COMP CALC.	Tension & Comp	-300.00 to 300.00 %	nc	
481	ROLL WIDTH/MASS	SETUP PARAMETERS::SPECIAL BLOCKS::TENS+COMP CALC.	Tension & Comp	0.00 to 100.00 %	nd	
482	FILTER T.C.	SETUP PARAMETERS::SPECIAL BLOCKS::TENS+COMP CALC.	Tension & Comp	0 to 20000	ne	
483	RATE CAL	SETUP PARAMETERS::SPECIAL BLOCKS::TENS+COMP CALC.	Tension & Comp	-100.00 to 100.00	nf	
484	NORMALISED dv/dt	SETUP PARAMETERS::SPECIAL BLOCKS::TENS+COMP CALC.	Tension & Comp	-300.00 to 300.00 %	ng	
485	INERTIA COMP O/P	SETUP PARAMETERS::SPECIAL BLOCKS::TENS+COMP CALC.	Tension & Comp	xxx.xx %	nh	Output
486	TENSION SCALER	SETUP PARAMETERS::SPECIAL BLOCKS::TENS+COMP CALC.	Tension & Comp	-3.0000 to 3.0000	ni	

Parameter Specification Table 10-15

Tag	Name	MMI Menu	CE Block	Range	MN	Notes
487	STATIC COMP	SETUP PARAMETERS::SPECIAL BLOCKS::TENS+COMP CALC.	Tension & Comp	-300.00 to 300.00 %	nj	
488	DYNAMIC COMP	SETUP PARAMETERS::SPECIAL BLOCKS::TENS+COMP CALC.	Tension & Comp	-300.00 to 300.00 %	nk	
489	REWIND	SETUP PARAMETERS::SPECIAL BLOCKS::TENS+COMP CALC.	Tension & Comp	Same as tag 4	nl	
491	STPT SUM 2 OUT 0	SETUP PARAMETERS::SPECIAL BLOCKS::SETPOINT SUM 2	Setpoint Sum 2	xxx.xx %	nn	Output, 2
492	STPT SUM 2 OUT 1	SETUP PARAMETERS::SPECIAL BLOCKS::SETPOINT SUM 2	Setpoint Sum 2	xxx.xx %	no	Output, 2
493	OUTPUT	SYSTEM::CONFIGURE I/O::ANALOG INPUTS::ANIN 2 (A3)	Analog Input 2	xxx.xx %	np	Output, 2
494	DESTINATION TAG	SYSTEM::CONFIGURE I/O::DIGITAL INPUTS::DIGITAL INPUT C4	Dig in C4	0 to 549	nq	2, 3
495	DESTINATION TAG	SYSTEM::CONFIGURE I/O::DIGITAL INPUTS::DIGITAL INPUT C5	Dig in C5	0 to 549	nr	2, 3
496	JOG/SLACK	SETUP PARAMETERS::AUX I/O	Aux I/O	Same as tag 18	ns	
497	ENABLE	SETUP PARAMETERS::AUX I/O	Aux I/O	Same as tag 18	nt	
498	LINE SPEED SPT	SETUP PARAMETERS::SPECIAL BLOCKS::TENS+COMP CALC.	Tension & Comp	-105.00 to 105.00 %	nu	
500	TEC OPTION TYPE	SERIAL LINKS::TEC OPTION	Tec Option	0 : NONE 1 : RS485 2 : PROFIBUS DP 3 : LINK 4 : DEVICE NET 5 : CAN OPEN 6 : LONWORKS 7 : TYPE 7	nw	
501	TEC OPTION IN 1	SERIAL LINKS::TEC OPTION	Tec Option	-32768 to 32767	nx	
502	TEC OPTION IN 2	SERIAL LINKS::TEC OPTION	Tec Option	-32768 to 32767	ny	
503	TEC OPTION IN 3	SERIAL LINKS::TEC OPTION	Tec Option	-32768 to 32767	nz	
504	TEC OPTION IN 4	SERIAL LINKS::TEC OPTION	Tec Option	-32768 to 32767	o0	
505	TEC OPTION IN 5	SERIAL LINKS::TEC OPTION	Tec Option	-32768 to 32767	o1	
506	TEC OPTION FAULT	SERIAL LINKS::TEC OPTION	Tec Option	0 : NONE 1 : PARAMETER 2 : TYPE MISMATCH 3 : SELF TEST 4 : HARDWARE 5 : MISSING	o2	Output
507	TEC OPTION VER	SERIAL LINKS::TEC OPTION	Tec Option	0x0000 to 0xFFFF	o3	Output, 1
508	TEC OPTION OUT 1	SERIAL LINKS::TEC OPTION	Tec Option	xxxxx	o4	Output, 1
509	TEC OPTION OUT 2	SERIAL LINKS::TEC OPTION	Tec Option	xxxxx	o5	Output, 1
510	PRODUCT CODE	Not on MMI		Not on MMI	o6	1, 2
511	LOCAL KEY ENABLE	SETUP PARAMETERS::OP-STATION::SET UP	Op Station	Same as tag 42	o7	
512	SETPOINT	SETUP PARAMETERS::OP-STATION::SET UP	Op Station	0.00 to 100.00 %	o8	1
513	JOG SETPOINT	SETUP PARAMETERS::OP-STATION::SET UP	Op Station	0.00 to 100.00 %	o9	1
514	RAMP ACCEL TIME	SETUP PARAMETERS::OP-STATION::LOCAL RAMP	Op Station	0.1 to 600.0 SECS	oa	
515	RAMP DECEL TIME	SETUP PARAMETERS::OP-STATION::LOCAL RAMP	Op Station	0.1 to 600.0 SECS	ob	
516	FORWARD	SETUP PARAMETERS::OP-STATION::START UP VALUES	Op Station	Same as tag 42	oc	
517	LOCAL	SETUP PARAMETERS::OP-STATION::START UP VALUES	Op Station	Same as tag 42	od	
518	PROGRAM	SETUP PARAMETERS::OP-STATION::START UP VALUES	Op Station	Same as tag 42	oe	

10-16 Parameter Specification Table

Tag	Name	MMI Menu	CE Block	Range	MN	Notes
519	SETPOINT	SETUP PARAMETERS::OP-STATION::START UP VALUES	Op Station	0.00 to 100.00 %	of	
520	JOG SETPOINT	SETUP PARAMETERS::OP-STATION::START UP VALUES	Op Station	0.00 to 100.00 %	og	
521	NOM MOTOR VOLTS	CONFIGURE DRIVE	Calibration	100 to 875 VOLTS	oh	3
522	NOT 570 STACK	RESERVED	Reserved	Same as tag 42	oi	4
523	ARMATURE CURRENT	CONFIGURE DRIVE	Calibration	2.0 to 15.0 AMPS	oj	3
524	FIELD CURRENT	CONFIGURE DRIVE	Calibration	0.2 to 4.0 AMPS	ok	3
525	COAST STOP	DIAGNOSTICS	Stop Rates	Same as tag 42	ol	Output
526	BY-PASS PASSWORD	PASSWORD	Reserved	Same as tag 42	om	4
527	MASTER BRIDGE	SETUP PARAMETERS::CURRENT LOOP	Current Loop	Same as tag 18	on	Output, 1
528	LAST ALARM	ALARM STATUS	Alarms	0x0000 : NO ACTIVE ALARMS 0x0001 : OVER SPEED 0x0002 : MISSING PULSE 0x0004 : FIELD OVER I 0x0008 : HEATSINK TRIP 0x0010 : THERMISTOR 0x0020 : OVER VOLTS (VA) 0x0040 : SPD FEEDBACK 0x0080 : ENCODER FAILED 0x0100 : FIELD FAILED 0x0200 : 3 PHASE FAILED 0x0400 : PHASE LOCK 0x0800 : 5703 RCY ERROR 0x1000 : STALL TRIP 0x2000 : OVER I TRIP 0xf005 : EXTERNAL TRIP 0x8000 : ACCTS FAILED 0xf001 : AUTOTUNE ERROR 0xf002 : AUTOTUNE ABORTED 0xf200 : CONFIG ENABLED 0xf400 : NO OP-STATION 0xf006 : REMOTE TRIP 0xff05 : PCB VERSION 0xff06 : PRODUCT CODE	oo	Output, 1
529	PNO 39	RESERVED		0x0000 to 0xFFFF	op	4
530	PNO 47	RESERVED		0x0000 to 0xFFFF	oq	Output, 4
531	PNO 55	RESERVED		0x0000 to 0xFFFF	or	4
532	PNO 63	RESERVED		0x0000 to 0xFFFF	os	4
533	PNO 71	RESERVED		0x0000 to 0xFFFF	ot	4
534	PNO 95	RESERVED		0x0000 to 0xFFFF	ou	4
535	REM.SEQ.ENABLE	SETUP PARAMETERS::AUX I/O	Aux I/O	Same as tag 42	ov	2
536	REM.SEQUENCE	SETUP PARAMETERS::AUX I/O	Aux I/O	0x0000 to 0xFFFF	ow	1
537	SEQ STATUS	SETUP PARAMETERS::AUX I/O	Aux I/O	0x0000 to 0xFFFF	ox	Output
538	CURRENT FBK.AMPS	DIAGNOSTICS	Current Loop	xxxx.x AMPS	oy	Output, 1, 3
539	FIELD I FBK.AMPS	DIAGNOSTICS	Current Loop	xxxx.x AMPS	oz	Output, 1, 3
540	REM TRIP INHIBIT	SETUP PARAMETERS::INHIBIT ALARMS	Alarms	Same as tag 19	p0	
541	REM TRIP DELAY	SETUP PARAMETERS::CALIBRATION	Alarms	0.1 to 600.0 SECS	p1	
542	REMOTE TRIP	ALARM STATUS	Alarms	Same as tag 42	p2	Output, 1
543	ZERO CAL INPUTS	CONFIGURE DRIVE		Same as tag 354	p3	1, 2, 3, 4
544	PCODE SAVE	Not on MMI		Same as tag 42	p4	1, 2
545	PCODE ID	Not on MMI		0 to 70	p5	1, 2
546	PCB VERSION	Not on MMI		Same as tag 42	p6	1, 2
547	SPD.FBK.FILTER	SETUP PARAMETERS::SPEED LOOP	Menus	0.000 to 1.000	p7	
548	OPSTATION LEDS	Not on MMI		0000 to FFFF	p8	
549	SPD LOOP O/P	DIAGNOSTICS	Speed Loop	-200 to 200 %	p9	Output, 2

Parameter Specification Table 10-17

Tag	Name	MMI Menu	CE Block	Range	MN Notes
550	ENABLE 12 PULSE	RESERVED		0 to 2	pa
551	MASTER BRIDGE	RESERVED		FALSE / TRUE	pb
552	SLAVE BRIDGE	RESERVED		FALSE / TRUE	pc
553	MAX BS DEAD TIME	RESERVED		1 to 6000	pd

10-18 Parameter Specification Table

Parameter Table: MMI Menu Order

1	FACTORY DEFAULTS	
2	MENU	
3	DIAGNOSTICS	
4	[089] SPEED DEMAND	
4	[207] SPEED FEEDBACK	
4	[297] SPEED ERROR	
4	[549] SPD LOOP OUTPUT	
4	[299] CURRENT DEMAND	
4	[298] CURRENT FEEDBACK	
4	[538] CURRENT FBK.AMPS	
4	[065] IaFbk UNFILTERED	
4	[066] IaDmd UNFILTERED	
4	[087] POS. I CLAMP	
4	[088] NEG. I CLAMP	
4	[067] ACTUAL POS I LIM	
4	[061] ACTUAL NEG I LIM	
4	[203] INVERSE TIME O/P	Reserved
4	[042] AT CURRENT LIMIT	
4	[077] AT ZERO SPEED	
4	[078] AT ZERO SETPOINT	
4	[079] AT STANDSTILL	
4	[113] RAMPING	
4	[080] PROGRAM STOP	
4	[525] COAST STOP	
4	[082] DRIVE START	
4	[084] DRIVE ENABLE	
4	[212] OPERATING MODE	
4	[169] FIELD ENABLED	
4	[183] FIELD DEMAND	
4	[300] FIELD I FBK.	
4	[539] FIELD I FBK.AMPS	
4	[181] RAW FIELD FBK	
4	[184] FLD.FIRING ANGLE	
4	[050] ANIN 1 (A2)	
4	[051] ANIN 2 (A3)	
4	[052] ANIN 3 (A4)	
4	[053] ANIN 4 (A5)	
4	[054] ANIN 5 (A6)	
4	[055] ANOUT 1 (A7)	
4	[056] ANOUT 2 (A8)	
4	[068] START (C3)	
4	[069] DIGITAL INPUT C4	
4	[070] DIGITAL INPUT C5	
4	[071] DIGIN 1 (C6)	
4	[072] DIGIN 2 (C7)	
4	[073] DIGIN 3 (C8)	
4	[074] DIGOUT 1 (B5)	
4	[075] DIGOUT 2 (B6)	
4	[076] DIGOUT 3 (B7)	
4	[264] RAISE/LOWER O/P	
4	[417] PID OUTPUT	
4	[416] PID CLAMPED	
4	[415] PID ERROR	
4	[086] SPT SUM OUTPUT	
4	[085] RAMP OUTPUT	
4	[063] SPEED SETPOINT	
4	[057] TERMINAL VOLTS	
4	[060] BACK EMF	
4	[308] TACH INPUT	
4	[058] UNFIL.TACH INPUT	
4	[206] ENCODER	
4	[059] UNFIL.ENCODER	
4	[062] UNFIL.SPD.FBK	
4	[064] UNFIL.SPD.ERROR	

Parameter Specification Table 10-19

4					__[083] CONTACTOR CLOSED	
4					__[122] HEALTH LED	
4					__[125] READY	
4					__[376] DRIVE RUNNING	
4					__[374] SYSTEM RESET	
3					SETUP PARAMETERS	
4					RAMPS	
5					__[002] RAMP ACCEL TIME	
5					__[003] RAMP DECEL TIME	
5					__[004] CONSTANT ACCEL	Reserved
5					__[118] RAMP HOLD	
5					__[005] RAMP INPUT	
5					__[266] % S-RAMP	
5					__[286] RAMPING THRESH.	
5					__[287] AUTO RESET	
5					__[288] EXTERNAL RESET	
5					__[422] RESET VALUE	
5					__[126] MIN SPEED	
4					AUX I/O	
5					__[161] AUX START	
5					__[227] AUX JOG	
5					__[168] AUX ENABLE	
5					__[094] AUX DIGOUT 1	
5					__[095] AUX DIGOUT 2	
5					__[096] AUX DIGOUT 3	
5					__[128] ANOUT 1	
5					__[129] ANOUT 2	
5					__[496] JOG/SLACK	
5					__[497] ENABLE	
5					__[535] REM.SEQ.ENABLE	
5					__[536] REM.SEQUENCE	
5					__[537] SEQ STATUS	
4					OP-STATION	
5					SET UP	
6					__[512] SETPOINT	
6					__[513] JOG SETPOINT	
6					__[511] LOCAL KEY ENABLE	
5					START UP VALUES	
6					__[519] SETPOINT	
6					__[520] JOG SETPOINT	
6					__[516] FORWARD	
6					__[518] PROGRAM	
6					__[517] LOCAL	
5					LOCAL RAMP	
6					__[514] RAMP ACCEL TIME	
6					__[515] RAMP DECEL TIME	
4					JOG/SLACK	
5					__[218] JOG SPEED 1	
5					__[219] JOG SPEED 2	
5					__[253] TAKE UP 1	
5					__[254] TAKE UP 2	
5					__[225] CRAWL SPEED	
5					__[228] MODE	
5					__[355] RAMP RATE	
4					RAISE/LOWER	
5					__[255] RESET VALUE	
5					__[256] INCREASE RATE	
5					__[257] DECREASE RATE	
5					__[261] RAISE INPUT	
5					__[262] LOWER INPUT	
5					__[258] MIN VALUE	
5					__[259] MAX VALUE	
5					__[307] EXTERNAL RESET	
4					SPECIAL BLOCKS	
5					DIAMETER CALC.	
6					__[424] LINE SPEED	
6					__[437] REEL SPEED	
6					__[425] MIN DIAMETER	

10-24 Parameter Specification Table

6				__ANIN 4 (A5)
7				__[239] CALIBRATION
7				__[240] MAX VALUE
7				__[241] MIN VALUE
7				__[250] DESTINATION TAG
6				__ANIN 5 (A6)
7				__[242] CALIBRATION
7				__[243] MAX VALUE
7				__[244] MIN VALUE
7				__[247] DESTINATION TAG
5				__ANALOG OUTPUTS
6				 __ANOUT 1 (A7)
7				__[245] % TO GET 10V
7				__[362] MODULUS
7				__[464] OFFSET
7				__[251] SOURCE TAG
6				 __ANOUT 2 (A8)
7				__[248] % TO GET 10V
7				__[363] MODULUS
7				__[465] OFFSET
7				__[252] SOURCE TAG
5				__DIGITAL INPUTS
6				 __DIGITAL INPUT C4
7				__[494] DESTINATION TAG
6				 __DIGITAL INPUT C5
7				__[495] DESTINATION TAG
6				 __DIGIN 1 (C6)
7				__[103] VALUE FOR TRUE
7				__[104] VALUE FOR FALSE
7				__[102] DESTINATION TAG
6				 __DIGIN 2 (C7)
7				__[106] VALUE FOR TRUE
7				__[107] VALUE FOR FALSE
7				__[105] DESTINATION TAG
6				 __DIGIN 3 (C8)
7				__[109] VALUE FOR TRUE
7				__[110] VALUE FOR FALSE
7				__[108] DESTINATION TAG
5				__DIGITAL OUTPUTS
6				 __DIGOUT 1 (B5)
7				__[195] THRESHOLD (>)
7				__[043] MODULUS
7				__[097] SOURCE TAG
7				__[359] INVERTED
6				 __DIGOUT 2 (B6)
7				__[196] THRESHOLD (>)
7				__[044] MODULUS
7				__[098] SOURCE TAG
7				__[360] INVERTED
6				 __DIGOUT 3 (B7)
7				__[197] THRESHOLD (>)
7				__[045] MODULUS
7				__[099] SOURCE TAG
7				__[361] INVERTED
5				__CONFIGURE 5703
6				__[134] SOURCE TAG
6				__[135] DESTINATION TAG
5				__BLOCK DIAGRAM
6				__[260] RAISE/LOWER DEST
6				__[293] RAMP O/P DEST
6				__[294] SPT SUM 1 DEST
6				__[400] PID O/P DEST
6				__[431] DIAMETER
6				__[442] TAPER
6				__[450] SETPOINT SUM 2
6				__[435] POS. I CLAMP
6				__[436] NEG. I CLAMP
6				__[478] TENS+COMP CALC.

Parameter Specification Table 10-25

5			INTERNAL LINKS	
6			LINK 1	
7			__[364] SOURCE TAG	
7			__[365] DESTINATION TAG	
6			LINK 2	
7			__[366] SOURCE TAG	
7			__[367] DESTINATION TAG	
6			LINK 3	
7			__[368] SOURCE TAG	
7			__[369] DESTINATION TAG	
6			LINK 4	
7			__[370] SOURCE TAG	
7			__[371] DESTINATION TAG	
6			LINK 5	
7			__[454] SOURCE TAG	
7			__[455] DESTINATION TAG	
6			LINK 6	
7			__[456] SOURCE TAG	
7			__[457] DESTINATION TAG	
6			LINK 7	
7			__[458] SOURCE TAG	
7			__[459] DESTINATION TAG	
6			LINK 8	
7			__[460] SOURCE TAG	
7			__[461] DESTINATION TAG	
6			LINK 9	
7			__[467] SOURCE TAG	
7			__[468] DESTINATION TAG	
6			LINK 10	
7			__[469] SOURCE TAG	
7			__[470] DESTINATION TAG	
6			LINK 11	
7			__[390] SOURCE TAG	
7			__[391] DESTINATION TAG	
7			__[392] ADVANCED	
7			__[393] MODE	
7			__[394] AUX.SOURCE	
6			LINK 12	
7			__[395] SOURCE TAG	
7			__[396] DESTINATION TAG	
7			__[397] ADVANCED	
7			__[398] MODE	
7			__[399] AUX.SOURCE	
4			RESERVED Reserved	
5			FACTORY USE ONLY	
6			DO NOT ALTER !!	
7			__[162] MIN MMI CYCLE TM	Reserved
7			__[163] ILOOP PI MODE	Reserved
7			__[164] TOGGLE PERIOD	Reserved
7			__[165] TOGGLE REF 1	Reserved
7			__[166] SEL. INT/CUR/SPD	Reserved
7			__[167] TOGGLE REF 2	Reserved
7			__[190] PEAK HW SLOPE	Reserved
7			__[226] PEAK HW OFFSET	Reserved
7			__[211] HEALTH INHIBIT	Reserved
7			__[194] DISC ADAPT POT	Reserved
7			__[193] TICK LENGTH	Reserved
7			__[310] AUTOCAL	Reserved
7			__[311] IAINST OFFSET	Reserved
7			__[213] ZERO CUR OFFSET	Reserved
7			__[214] ZCD THRESHOLD	Reserved
7			__[221] MMI FILTER T.C.	Reserved
7			__[222] PRED STEP	Reserved
7			__[223] SCAN THRESHOLD	Reserved
7			__[034] FIELD FBKSTOP	Reserved
7			__[035] FIELD FFRSTOP	Reserved
7			__[036] IFFB DELAY	Reserved
7			__[154] II	Reserved

10-26 Parameter Specification Table

7				__[101] MIN BS DEAD TIME	Reserved
7				__[553] MAX BS DEAD TIME	Reserved
7				__[276] PLL PROP	Reserved
7				__[277] PLL INT	Reserved
7				__[386] FILTER T.C.	Reserved
7				__[279] ARM ENDSTOP	Reserved
7				__[283] SCAN TC	Reserved
7				__[280] HF C/O DISC GAIN	Reserved
7				__[281] HF C/O FILTER TC	Reserved
7				__[282] BEMF THRESHOLD	Reserved
7				__[265] ANALOG IP OFFSET	Reserved
7				__[388] SYNC OFFSET	Reserved
7				__[205] di/dt	Reserved
7				__[335] DISABLE MEAN FBK	Reserved
7				__[336] CHANGEOVER BIAS	Reserved
7				__[471] STANDBY FIELD	Reserved
7				__[476] 3-PHASE FIELD	Reserved
7				__[550] ENABLE 12 PULSE	Reserved
7				__[551] MASTER BRIDGE	Reserved
7				__[552] SLAVE BRIDGE	Reserved
7				__[522] NOT 570 STACK	Reserved
7				__[158] OP STATION ERROR	Reserved
7				__[040] SYSTEM IO	Reserved
7				__[046] ILOOP SUSPEND	Reserved
7				__[114] SEQ STATE	Reserved
7				__[117] HEALTH INHIBIT	Reserved
7				__[215] G&L POWER METER	Reserved
7				__[267] POSITION COUNT	Reserved
7				__[275] POSITION DIVIDER	Reserved
7				__[387] RAW POS COUNT	Reserved
7				__[278] PLL ERROR	Reserved
7				__[295] FILTER INPUT	Reserved
7				__[296] FILTER OUTPUT	Reserved
7				__[372] R/L DELTA	Reserved
7				__[373] SYS RAMP DELTA	Reserved
7				__[389] PERCENT RPM	Reserved
7				__[529] PNO 39	Reserved
7				__[530] PNO 47	Reserved
7				__[531] PNO 55	Reserved
7				__[532] PNO 63	Reserved
7				__[533] PNO 71	Reserved
7				__[534] PNO 95	Reserved
4				__PEEK	
5				__[123] PEEK DATA	
5				__[124] PEEK SCALE	
4				__miniLINK	
5				__[339] VALUE 1	
5				__[340] VALUE 2	
5				__[341] VALUE 3	
5				__[342] VALUE 4	
5				__[343] VALUE 5	
5				__[344] VALUE 6	
5				__[345] VALUE 7	
5				__[379] VALUE 8	
5				__[380] VALUE 9	
5				__[381] VALUE 10	
5				__[382] VALUE 11	
5				__[383] VALUE 12	
5				__[384] VALUE 13	
5				__[385] VALUE 14	
5				__[346] LOGIC 1	
5				__[347] LOGIC 2	
5				__[348] LOGIC 3	
5				__[349] LOGIC 4	
5				__[350] LOGIC 5	
5				__[351] LOGIC 6	
5				__[352] LOGIC 7	
5				__[353] LOGIC 8	

Parameter Specification Table 10-27

	PARAMETER	DESCRIPTION	
3	—	CONFIGURE DRIVE	
4	__[039]	CONFIGURE ENABLE	
4	__[521]	NOM MOTOR VOLTS	
4	__[523]	ARMATURE CURRENT	
4	__[524]	FIELD CURRENT	
4	__[543]	ZERO CAL INPUTS	Reserved
4	__[209]	FLD.CTRL MODE	
4	__[210]	FLD.VOLTS RATIO	
4	__[018]	AUTOTUNE	
4	__[047]	SPEED FBK SELECT	
4	__[024]	ENCODER LINES	
4	__[022]	ENCODER RPM	
4	__[049]	ENCODER SIGN	
4	__[013]	SPD.INT.TIME	
4	__[014]	SPD.PROP.GAIN	

10-28 Parameter Specification Table

TECHNICAL SPECIFICATIONS

Environmental Details	
Operating Temperature	Frame 1 : 0°C to +45°C Frame 2 : 0°C to +45°C Frame 4 : 0°C to +40°C Frame 5 : 0°C to +40°C Frame H : 0°C to +40°C Operating temperature is defined as the ambient temperature to the immediate surround of the Converter, when the Converter and other equipment adjacent to it is operating at worst case conditions. Output current values should be derated at 1% per degree Centigrade above rated temperature up to a maximum of 55°C.
Storage Temperature	-25°C to +55°C
Shipping Temperature	-25°C to +70 °C
Product Enclosure Rating	IP00 (Europe) [Frame 1 unit is IP20] UL Open Type (North America/Canada) If the product enclosure is totally enclosed, the exposed metal surface dissipates approximately 50W/m ² for a 10°C temperature rise of internal air above ambient.
Altitude	If >500 metres (1650 feet) above sea level, derate Motor Power rating by 1% per 200 metres (660 feet) to a maximum of 5,000 metres (16,500 feet)
Humidity	Maximum 85% relative humidity at 40°C non-condensing
Atmosphere	Non flammable, non corrosive and dust free
Climatic Conditions	Class 3k3, as defined by EN60721-3-3 (1995)
Safety	
Europe	EN50178 (1998), when fitted inside a cubicle
North America/Canada	UL508C
Overvoltage Category	Overvoltage Category III (3-phase supply), Overvoltage Category II (auxiliary supply)
Pollution Degree	Pollution Degree 2

EMC Compliance	
All models	European Community Directive 89/336/EEC
All models	EN50082-1 (1992) and EN50082-2 (1995) for immunity
If fitted with specified external filters (except Frame H)	EN50081-2 (1994) Class A conducted emissions

11-2 Technical Specifications

Electrical Ratings - Power Circuit

Refer to Chapter 3: "Earth Fault Monitoring Systems" for circuit breaker details.
Motor HP ratings as NEC Table 430-147: "Full Load Current in Amperes, DC Motors"

Output Current @ 150% and 200% * (A)	Output Current @ 100% Continuous * (A)	Power @ 500V dc (kW)	Motor HP @ 500V dc (HP)	Field Current (A)	Total Losses @ Full Load (W)	Symmetrical Fault Current rms (kA)
Frame 1						
15	15	7	7.5	4	57	5
35	35	15	20	4	117	5
Frame 2						
40	40	18	25	10	132	10
70	70	30	40	10	234	10
110	110	50	60	10	354	10
165	165	75	100	10	519	10
Frame 3						
270	270	120	150	10	840	10
Frame 4						
380	420	150	200 ★	30	1230	18
500	550	225	300 ★	30	1590	18
725	800	327	400 ★	30	2265	30
830	910	335	500 ★	30	2580	30
Frame 5						
1580	1740	650	900 ★	30	4890	85
Frame H						
1050	1200	550	700 †	60	3780	100
1450	1700	750	1000 †	60	5280	100
2000	2200	1000	1250 †	60	6780	100
2400	2700	1200	1500 †	60	8280	100

* The output current figures are given at 100% Continuous (no overload), and with overloads of 150% for 30 seconds or 200% for 10 seconds.

Output current values should be derated at 1% per degree Centigrade above rated temperature up to a maximum of 55°C.

Output current values should be derated at an altitude of 500 metres above sea level at a rate of 1% per 200 metres to a maximum of 5000 metres.

★ These products are suitable for supplies up to 600V ac and armature voltages of 700V dc, hence output power ratings can be increased by up to 140%

† These products are suitable for supplies up to 690V ac and armature voltages of 750V dc, hence output power ratings can be increased by up to 150%

Power Supply Details			
3-Phase Supply	LV Build	All Frames	110-220V ac, 50/60Hz \pm 5%, line-to-line, ground referenced (TN) and non-ground referenced (IT)
	MV Build (standard)	All Frames	220-500V ac, 50/60Hz \pm 5%, line-to-line, ground referenced (TN) and non-ground referenced (IT)
	HV Build	Frame 4 Frame 5	500-600V ac, 50/60Hz \pm 5%, line-to-line, ground referenced (TN) and non-ground referenced (IT)
		Frame H	500-690V ac, 50/60Hz \pm 5%, line-to-line, ground referenced (TN) and non-ground referenced (IT)
Supply Current		(0.9 x I _{dc}) Amps ac rms	
Field Supply Current		(1 x I _{dc}) Amps ac rms (build related)	
Field Supply Voltage		Build-related	
3 Phase Input		3-phase rotation insensitive, no adjustment necessary for frequency change	

Auxiliary Power Supply Details	
Auxiliary Supply	110-230V \pm 10%, 50-60Hz \pm 10%, single phase, Overvoltage Category II Where auxiliary cooling fans are used, then the supply is set by the requirement for the fan, i.e. 115V \pm 10% or 230V \pm 10%. Refer to the Model No. and Chapter 2: "An Overview of the Converter" - Understanding the Product Code
Auxiliary Supply Current	3A ac rms maximum. Nominal current used for power supplies: 0.5A at 115V ac 0.25A at 230V ac Fan current for integral fans: refer to Cooling, page 11-19. The remainder is available for driving the AC Contactor
Contactor Output	3A maximum at the auxiliary voltage

11-4 Technical Specifications

AC Line Choke (Frames 1, 2, 3, 4 & 5)

To correctly isolate the 590+ drive from the ac power system, and to protect other equipment from transients on the power system, always use the recommended external ac line choke (or alternatively a transformer may achieve the necessary isolation).

Note that the Frame 5 requires two ac line chokes (one in front of each of the paralleled converters). This provides isolating impedance between the drive and its ac power source. It also provides the necessary impedance between the paralleled converters, forcing them to share the total motor current evenly. The Frame 5 drive must still use two ac line chokes when a transformer is used for isolation, however, the chokes can be of a much lower inductance, typically 3-5 μH .

Armature Current Rating (A)	AC Rating (A)	Inductance (μH)		Eurotherm Drives Part No.	
		500Vac	600Vac	500Vac	600Vac
For use without filters					
Frame 1					
15	13.5	50 μH	-	CO466448U015	-
35	36	50 μH	-	CO466448U040	-
Frame 2					
40	36	50 μH	-	CO466448U040	-
70	63	50 μH	-	CO466448U070	-
110	100	50 μH	-	CO466448U110	-
165	148.5	50 μH	-	CO466448U165	-
Frame 3					
270	360	50 μH	-	CO057960	-
AC Line Chokes @ 2% line impedance for conformance with EN55011 Class A when used with specified filters.					
Frame 1					
15	13.5	1130 μH	-	CO466449U015	-
35	36	424 μH	-	CO466449U040	-
Frame 2					
40	36	424 μH	-	CO466449U040	-
70	63	242 μH	-	CO463037	-
110	100	154 μH	-	CO463038	-
165	148.5	113 μH	-	CO463039	-
Frame 3					
270	360	50 μH	-	CO057960	-
AC Line Chokes @ 1% line impedance for conformance with EN55011 Class A when used with specified filters.					
Frame 4					
380	342	-	30 μH	-	CO466709U038
500	450	-	25 μH	-	CO466709U050
725	653	-	20 μH	-	CO466709U073
830	747	-	15 μH	-	CO466709U083
Frame 5 (2 chokes required)					
0831-1200	747	-	20 μH	-	CO466709U073
0831-1200 (use with transformer only)	747	-	5 μH	-	CO466709U120
1201-1580	747	-	15 μH	-	CO466709U083
1201-1580 (use with transformer only)	747	-	5 μH	-	CO466709U160

AC Line Choke (Frame H)

Always use the recommended external AC Line Choke.

DC Rating	AC Current	Inductance	Eurotherm Drives Part No.	
AC Line Choke @ 2% line impedance.				
Frame H				
1200	LV	1080A	15 μ H	CO466250U012
	HV	1080A	20 μ H	CO466251U012
1700	LV	1620A	10 μ H	CO466250U017
	HV	1620A	15 μ H	CO466251U017
2200	LV	1980A	10 μ H	CO466250U022
	HV	1980A	15 μ H	CO466251U022
2700	LV	2520A	7.5 μ H	CO466250U027
	HV	2520A	10 μ H	CO466251U027

External AC Supply (RFI) Filters

Filters must only be fitted on the mains side of the contactor.

AC supply filter part numbers for conformance with EN55011 Class A.

Armature Current Rating (A)	Total Filter Watt Loss (W)	Eurotherm Filter Part No.
Frame 1		
15	11	1 off CO466516U015
35	16	1 off CO466516U040
Frame 2		
40	16	1 off CO466516U040
70	16	1 off CO466534U070
110	18	1 off CO466534U110
165	25	1 off CO466534U165
Frame 3		
246	50	1 off CO389456
Frame 4		
380 (please contact Eurotherm Drives)		
500 (please contact Eurotherm Drives)		
725 (please contact Eurotherm Drives)		
830 (please contact Eurotherm Drives)		
Frame 5		
1580 (please contact Eurotherm Drives)		

11-6 Technical Specifications

Power Semiconductor Protection Fuses (Frames 1, 2, 3, 4 & 5)

For fuses where compliance to UL Standards are required, refer to Chapter 12:
"Installing the Converter" – Requirements for UL Compliance.

Controller Rating (A)	Line Fuse Rating (A)	Eurotherm Part No.	Fuse I ² t (kA ² s)	Thyristor I ² t (kA ² s)
Frame 1				
15	25	CS470445U025 *	0.31	0.72
35	40	CH570044	0.46	0.72
Frame 2				
40	40	CH570044	0.46	1.15
70	80	CH570084	2.55	8
110	160	CH580164	7.5	15
165	200	CH580025	15	19.1
Frame 3				
270	500	CH590554	?	?
Frame 4				
380	550	CH590554	135	240
500	700	CH590075	300	306
725	900	CH590095	670	781
830	1000	CH590016	945	1125
Frame 5				
1580	2 x 1000	CH590016	945	1125

Power Semiconductor Protection Fuses (Frame H)

For fuses where compliance to UL Standards are required, refer to Chapter 12:
"Installing the Converter" - Requirements for UL Compliance.

Controller Rating (A)	Line Fuse Rating (A)	Eurotherm Part No.	Limb Fuse Rating	Eurotherm Part No.
Frame H				
1200	500 x 2	CS466260U050	350 x 2	CS466261U035
1700	800 x 2	CS466260U080	550 x 2	CS466261U055
2200	1000 x 2	CS466260U100	700 x 2	CS466261U070
2700	1250 x 2	CS466260U125	900 x 2	CS466261U090

* Ferrule fuse 14 x 51mm, for use in ST14 Fuse Holder (CP054175)

We recommend that all 590+ drives are protected by semiconductor fuses.

1200-2700A units are fitted with internal fuses:

- the 4Q (590+) units have limb fuses
- the 2Q (591+) units have line fuses

Power Supply Fuses			
Power Board	Identification	Fuse Rating	Eurotherm Part No.
Frame 1			
AH466407 (terminal board)	FS1, 5x20mm glass slow-blow (for auxiliary supply, contactor, fan supply)	3A	CH540033
Frame 2			
AH470330	FS1, 5x20mm glass slow-blow (for auxiliary supply, contactor, fan supply)	3A	CH540033
Frame 3			
AH385851	FS1, 5x20mm glass slow-blow (for auxiliary supply, contactor, fan supply)	3A	CH540033
Frame 4 & 5			
AH466701	FS3 and FS4, 5x20mm glass slow-blow (for auxiliary supply, contactor, fan supply)	3A	CH540033
Frame H			
AH466001	FS1, 5x20mm glass slow-blow (for auxiliary supply, contactor, fan supply)	3A	CH540033

Field Fuses			
Identification		Fuse Rating	Eurotherm Part No.
Frames 1, 2 & 3			
10x38mm		10A	CS470407U010
Frame 4 & 5			
10x38mm		30A	CS470407U030
External field fuses are required for Frame H units.			

Earthing/Safety Details	
Grounding	<p>Permanent earthing is mandatory on all units because the earth leakage current exceeds 3.5mA ac/10mA dc under normal operating conditions. Permanent earthing can be made in two ways:</p> <ol style="list-style-type: none"> 1. By using a copper conductor of at least 10mm² cross-sectional area. 2. By using a second conductor, through separate terminals electrically parallel to the protective conductor. <p>Note: Each conductor itself must meet the local requirements for a protective earth conductor.</p>
Input Supply Details (TN) and (IT)	Units with or without external filters are suitable for use on earth referenced (TN) supplies, but units used with a filter are not recommended for non-earth referenced (IT) supplies..
Earth Leakage Current	>50mA (all models)

Terminal Definitions (Digital/Analog Inputs & Outputs)

User inputs/outputs are IEC1131 compliant.

<p>Digital Input</p>	<p>Rated Voltage:</p> <ul style="list-style-type: none"> Off Region: input voltage input current Transition Region: input voltage input current On Region: input voltage input current <p>Input Impedance Sample Time</p>	<p>24V dc</p> <p>minimum -3V, maximum 5V minimum not defined, maximum 15mA</p> <p>minimum 5V, maximum 15V minimum 0.5mA, maximum 15mA</p> <p>minimum 15V, maximum 30V minimum 2mA, maximum 15mA</p> <p>4.7kΩ 10ms</p>
<p>Digital Output</p> <p>These outputs are active high and source current from the terminal to the load. Thus the load must be connected between the output and the signal ground. A free-wheel diode is included in the output to protect the output transistor when switching inductive loads such as relays.</p>	<p>Digital Output Voltage Digital Output Current Output Update Rate Output Impedance Source/Sink Rated Current Temporary Overload Overload Protection Overload Recover Reverse Voltage Protection Operating Voltage Off state leakage current</p>	<p>+24V dc +100mA maximum source 10ms Negligible up to 50mA load, short circuit protection provided. Source 0.1A None Indefinite Automatic Yes <30V dc <0.4mA</p>
<p>Analog Input/Output</p> <p>Terminal blocks A, B, and C are located on the control board each block being a 9 way plug-in connector. In addition to terminal blocks A, B and C, terminal blocks G and H provide connections when the two option modules are fitted on the control board.</p>	<p>Input Resolution Output Resolution Input Impedance</p> <p>Input Impedance Limit Maximum Input Sample Rate Input Overload Capability</p> <p>Output Capacity Output Update Rate Output Overdrive Capability</p>	<p>12 Bit plus sign, i.e. 10mV = 0.025% of full scale deflection 10 Bit plus sign, i.e. 10mV = 0.1% of full scale deflection 100kΩ with a 1ms filter for Analog I/P (A3) and 2ms for others. ≥10kΩ (signal range -10V to +10V) 10ms (typically), 3ms for Analog I/P 2 (A3) 10%, i.e. maximum recognisable voltage 11V. Analog Tachogenerator input should be applied to Terminal G3 on Calibration Option Card only. 10V at 5mA. Short circuit protected 10ms 10%, i.e. maximum output 11V</p>

Terminal Information - Power Board (Frames 1, 2, 4 & 5)

Note that on Frame 1 and 2 units, L1, L2, L3, A+ and A- terminals are located on a separate Terminal Board. On Frame 3, 4 & 5 units, they are busbar connections.

Frame 3 units have terminal designations D1 to D8, shown in brackets in the Terminal Number column of this table.

Terminal Description	Terminal Function	Signal Level	Terminal Number
Mains Supply L1	Three phase mains power input, phase reference Line 1	Refer to Power Supply Details, page 11-3.	L1
Mains Supply L2	Three phase mains power input, phase reference Line 2	Refer to Power Supply Details, page 11-3.	L2
Mains Supply L3	Three phase mains power input, phase reference Line 3	Refer to Power Supply Details, page 11-3.	L3
Armature connection positive A+	Converter dc power output, reference Armature Positive connection to dc motor	Maximum voltage dependent upon the supply voltage, the ratio being: Vout is approximately equal to 1.15Vac supply	A+
Armature connection negative A-	Converter dc power output, reference Armature Negative connection to dc motor	Maximum voltage dependent upon the supply voltage, the ratio being: Vout is approximately equal to 1.15Vac supply	A-
External field supply FL1 External field supply FL2 This feature not available on Frame 1 units	External single phase ac Line 1 input to field bridge. External single phase ac Line 2 input to field bridge. Required AC Input Voltage = 1.11 x Nominal DC Output. The field regulator will control the field current provided that the Nominal DC Output voltage exceeds the field voltage by at least 10%. i.e. $V_{AC} = 1.11 \times V_{DC}$ and $V_{DC} = 1.1 \times V_{FIELD}$ therefore $V_{AC} = 1.22 \times V_{FIELD}$ The external AC supply must be fitted with high speed fuses to protect the field regulator. For controllers with 10A field capability 10A fuses should be used. <i>Note: When using an external ac input it is important to have the correct phase relationship on the terminals. The supply must be derived from L1 (Red) and L2 (Yellow) phases directly or indirectly through a transformer. L1 must be connected to FL1, and L2 to FL2.</i>	500V ac maximum, 50-60Hz line-to-line 500V ac maximum, 50-60Hz line-to-line	FL1 (D1) FL2 (D2)

11-10 Technical Specifications

Terminal Information - Power Board (Frames 1, 2, 4 & 5)

Note that on Frame 1 and 2 units, L1, L2, L3, A+ and A- terminals are located on a separate Terminal Board. On Frame 3, 4 & 5 units, they are busbar connections.

Frame 3 units have terminal designations D1 to D8, shown in brackets in the Terminal Number column of this table.

Terminal Description	Terminal Function	Signal Level	Terminal Number
Field Output F-	DC supply for motor field connections. The DC output voltage at these terminals will depend upon the AC supply voltage and the mode of field control. Voltage Control The output voltage will be determined by the ratio parameter in the field variables. The relationship between the dc output voltage and AC input voltage is determined by the equation:- $V_{dc} = \frac{V_{ratio} \times VAC}{100}$ The default value of Vratio is 90% hence the DC output voltage will be the same as for a full wave diode rectifier i.e., 90% is maximum output.	0.9 x Vac	F- (D3)
Field Output F+	DC supply for motor field connections.	0.9 x Vac	F+ (D4)
Auxiliary supply Aux N Auxiliary supply Aux L	Neutral Line These terminals are the mains input connections for the switch mode power supply and contactor control relay supply. Refer to the Product Code (Block 8) for the specified auxiliary voltage. Refer to Cooling, page 11-19 when using separate ac fans, (Frame H units).	110-230V 50-60Hz line-to-line 110-230V 50-60Hz line-to-line	CONTROL N (D7) L (D8)
Main contactor coil Con L	Line This terminal is the switched output from the contactor control relay and is derived from the auxiliary supply at terminal D8. The output is internally fused at 3A hence contactor coils having a high pick-up current must be operated via a slave relay. <i>Note: The contacts of the Contactor Control Relay are suppressed by a series connected resistor (680 Ohms) and capacitor (22nF) to protect the relay contacts. Users should be aware that when the contactor Control Relay is "De-energised", a leakage current of approximately 2mA can be expected and this should be considered when interfacing to these terminals. Typically, there could be the energisation of very sensitive relays.</i>	Auxiliary Supply Voltage	EXT CONTACTOR 3 (D5)
Main contactor coil Con N	Neutral This terminal is internally connected to the auxiliary supply neutral and provides a convenient connection point for the contactor coil neutral connection.	Auxiliary Supply Voltage	4 (D6)

Terminal Information - Power Board (Frames 1, 2, 4 & 5)

Note that on Frame 1 and 2 units, L1, L2, L3, A+ and A- terminals are located on a separate Terminal Board. On Frame 3, 4 & 5 units, they are busbar connections.

Frame 3 units have terminal designations D1 to D8, shown in brackets in the Terminal Number column of this table.

Terminal Description	Terminal Function	Signal Level	Terminal Number
Thermistor Therm +	<p>Isolated Thermistor Input - positive</p> <p>It is good practice to protect DC motors against sustained thermal overloads by fitting temperature sensitive resistors or switches in the field and interpole windings of the machine.</p> <p>The controller complies with the requirements of IEC 34-11-2-2 and is suitable for use with Mark A detectors.</p> <p>These devices have a low resistance (typically 200Ω) up to a reference temperature 125°C). Above this temperature, their resistance rises rapidly to greater than 4kΩ. The preferred installation is for three detectors to be connected in series between terminals Th1 and Th2.</p> <p>The 590+ will indicate a motor overtemperature alarm if the external resistance between Th1 and Th2 exceeds 3kΩ. The alarm can be reset when the resistance falls below 750Ω.</p> <p>Terminals Th1 and Th2 must be jumpered if overtemperature sensors are not used.</p>	See description	<p>MOTOR THERMISTOR Th1 (THERM+)</p> <p>(THERM+ & THERM -, found on Frame 3 units, are located on a separate pcb to the left of the power board in the door assembly)</p>
Thermistor Therm -	<p>Isolated Thermistor Input - negative</p> <p>See description above</p>	See description	Th2 (THERM-)
PE	Protective ground – incoming ground	-	STUDS
PE	Protective ground – motor ground	-	STUDS
PE	Protective ground	-	STUDS

11-12 Technical Specifications

Terminal Information – Control Board

This Control Board is common to all 590+ units.

Terminal Description	Terminal Function	Signal Level	Configurable	Terminal Number
TERMINAL BLOCK A				
0V (Signal)	Zero Volt Reference	0V	N/A	A1
Analog Input 1	Speed Setpoint No. 1	+10V = Full speed setpoint forward -10V = Full speed setpoint reverse	YES	A2
Analog Input 2	Aux. Speed Setpoint/ Current Demand The function of this input is determined by Digital Input No. 3 at terminal C8. C8 open circuit = Speed Setpoint C8 at +24V = Current Demand	+10V = Full speed setpoint forward -10V = Full speed setpoint reverse in speed setpoint mode. +10V = 100% Positive current demand. -10V = 100% Reverse current demand.	NO	A3
Analog Input 3	Ramped Speed Setpoint	+10V = Full speed setpoint -10V = Full speed setpoint reverse	YES	A4
Analog Input 4	Aux. Current Clamp -ve	+10V = 200% Positive current demand -10V = 200% Reverse current clamp	YES	A5
Analog Input 5	Main Current Limit/ Aux. Current Clamp +ve The function of analog inputs 4 and 5 is determined by digital Input No.1 on terminal C6. C6 open circuit. Analog inputs No.5 = Main Current Limit. C6 at +24V. Analog input No. 5 = Auxiliary Current Clamp Positive. Analog Input No. 4 = Auxiliary Current Clamp Negative.		YES	A6
Analog Output 1	Speed Feedback	+10V = Full speed feedback forward. -10V = Full speed feedback reverse.	YES	A7
Analog Output 2	Total Speed Setpoint	+10V = Full speed feedback forward. -10V = Full speed feedback reverse.	YES	A8
Current Meter Output	Buffered Armature Current Output The output can be selected as either Bipolar or Unipolar by the Armature I parameter.	<u>Bipolar Mode</u> +10V = 200% output current forward. -10V = 200% output current reverse. <u>Unipolar Mode</u> +10V = 200% output current.	NO	A9

Terminal Information – Control Board

This Control Board is common to all 590+ units.

Terminal Description	Terminal Function	Signal Level	Configurable	Terminal Number
TERMINAL BLOCK B				
0V (Signal)	Zero Volt Reference	0V	N/A	B1
Not Connected	Not Connected			B2
+10V DC Reference	User +10V Reference	+10V at 10mA short circuit protected	N/A	B3
-10V DC Reference	User -10V Reference	-10V at 10mA short circuit protected	YES	B4
Digital Output 1	Zero Speed Detected The operating level of this output can be modified by the standstill zero threshold parameter to give the desired accuracy of operation	+24V at zero speed (100mA maximum)	YES	B5
Digital Output 2	Drive Healthy (Drive Operational) This output is true when the controller is Healthy.	+24V when Healthy (100mA maximum)	YES	B6
Digital Output 3	Drive Ready This output is true when the controller is ready to function, i.e., "locked" into the mains.	+24V when Ready (100mA maximum)	YES	B7
Program Stop Input	Program Stop When the Program Stop input is held at +24V, the drive operates as required by the inputs. When the Program Stop is open circuit or at zero volts, the controller provides a controlled or program stop as defined by the Program Stop parameters.	+24V drive run 0V (o/c) drive program stop Threshold +16V	NO	B8
Coast Stop Input	Coast Stop When the Coast Stop input is at +24V, the controller operates normally. When the Coast Stop is at zero volts or open circuit, the main contactor is open and the drive no longer operates. The motor coasts to rest.	+24V drive run 0V (o/c) drive coasts to rest. Threshold +16V	NO	B9

11-14 Technical Specifications

Terminal Information – Control Board

This Control Board is common to all 590+ units.

Terminal Description	Terminal Function	Signal Level	Configurable	Terminal Number
TERMINAL BLOCK C				
0V (Signal)	Zero Volt Reference	0V	N/A	C1
External Trip Input	An external interlock or permissive.	External permissive element should be connected to C1 to run. If not using this feature, connect a jumper between C1 and C2. May be used as an unisolated motor thermal input	NO	C2
Start/Run Input	Start/Run When an input is applied to this terminal, the main contactor will close and the controller will operate provided there are no alarms, program stop/coast stop signals are high and the controller is enabled. When the input is removed the controller will perform a regenerative stop to zero speed. A regenerative stop can only be achieved by a 4 quad regenerative controller; the 2 quad non-regenerative controller will coast to zero speed.	+24V = True/Run 0V (o/c) = False/Normal Stop Threshold + 16V	NO	C3
Jog Input	Jog When the Jog Input is held at +24V, the drive jogs provided input C3 is low. When the Jog Input is removed the drive will ramp down to zero obeying the Jog Ramp Rate.	+24V = True/Jog 0V = False/Stop Threshold +16V	YES	C4
Enable Input	Enable The Enable Input provides a means of electronically inhibiting controller operation. If the enable input is not true all control loops will be inhibited and the controller will not function.	+24V = True/Enable 0V = False/Inhibit Threshold +16V	YES	C5
Digital Input 1	Current Clamp Select This input alters the configuration of the current clamps. With no connection, i.e., false, Analog I/P 5 provides a unipolar current limit. When true, Analog I/P5 is the positive current clamp, Analog I/P 4 is the negative current clamp	+24V = True/Bipolar Clamp 0V = False/Unipolar Clamp Threshold +16V	YES	C6

Terminal Information – Control Board

This Control Board is common to all 590+ units.

Terminal Description	Terminal Function	Signal Level	Configurable	Terminal Number
Digital Input 2	<p>Ramp Hold</p> <p>If the input is held true the S-Ramp output is frozen at the last value irrespective of the Ramped Setpoint Input. When false the S-Ramp Output follows the Ramped Setpoint Input with a delay determined by the Acceleration and Deceleration Ramped time parameters.</p>	<p>+24V = True/Hold</p> <p>0V = False/Ramp</p> <p>Threshold + 16V</p>	YES	C7
Digital Input 3	<p>Current Demand Isolate</p> <p>This input alters the drive operation from Speed Control to Current Control. When digital input No. 3 is true, analog input No. 2 provides the current demand and the speed loop is disconnected. When false the speed loop is in control and analog input No. 2 is an auxiliary speed setpoint.</p>	<p>+24V = True/Current</p> <p>0V = False/Speed</p> <p>Threshold + 16V</p>	YES	C8
+24V Supply	+24V	<p>Maximum output current: 200mA</p> <p>Note that the maximum combined consumption for digital outputs 1, 2 & 3 and C9 should not exceed 300mA.</p> <p>Some typical loads are given below:</p> <p>Microtach : 75mA</p> <p>Relays : 50mA each</p> <p>Fiber Optic ancillaries : 50mA each</p> <p>DeviceNetTechnology Box : 50mA</p>	N/A	C9

11-16 Technical Specifications

Terminal Information (Frame H)

These terminals are located externally on the product.

Terminal Description	Terminal Function	Terminal Number
Three phase supply	Drive supply	L1 - L3
Armature + Armature -	Drive output to motor armature Drive output to motor armature	A+ A-
External field supply (Red Phase) External field supply (Yellow Phase)	External single phase ac Line 1 input to field bridge. External single phase ac Line 2 input to field bridge. Required AC Input Voltage = 1.11 x Nominal DC Output. The field regulator will control the field current provided that the Nominal DC Output voltage exceeds the field voltage by at least 10%. i.e. $V_{AC} = 1.11 \times V_{DC}$ and $V_{DC} = 1.1 \times V_{FIELD}$ therefore $V_{AC} = 1.22 \times V_{FIELD}$ The external AC supply must be fitted with high speed fuses to protect the field regulator. For controllers with 10A field capability 10A fuses should be used, those with 20A field capability 20A fuses, etc. <i>Note: When using an external AC input it is important to have the correct phase relationship on the terminals. The supply must be derived from L1 (Red) and L2 (Yellow) phases directly or indirectly through a transformer. L1 must be connected to FL1, and L2 to FL2.</i>	FL1 FL2
Field Output (DC+) Field Output (DC-)	DC supply for motor field connections. DC supply for motor field connections. The DC output voltage at these terminals will depend upon the AC supply voltage and the mode of field control. Please refer to the Product Manual for details of the drive capability and operation. Maximum drive field output capability is 60A DC.	F+ F-
External Armature Volts Sense (+) External Armature Volts Sense (-)	This connection can be used if a more accurate value of armature voltage is required, for example a DC line reactor may be fitted. This terminal should be connected directly to the positive motor armature terminal. This terminal should be connected directly to the negative motor armature terminal (see above).	MVA+ MVA-
Auxiliary Supply Live 110-240V Auxiliary Supply Neutral	These terminals are the mains input connections for control supply transformer and contactor relay supply	L N
Main contactor coil V AC Main contactor coil V AC	This terminal is internally connected to the auxiliary supply neutral and provides a convenient connection point for the contactor coil neutral connection This terminal is the switched output from the contactor control relay and is derived from the auxiliary supply. The output is internally fused at 3A hence contactor coils having a high pick-up current must be operated via a slave relay. <i>Note: The contacts of the Contactor Control Relay are suppressed by a series connected resistor (680 Ohms) and capacitor (22nF) to protect the relay contacts. Users should be aware that when the contactor Control Relay is "De-energised", a leakage current of approximately 2mA can be expected and this should be considered when interfacing to these terminals. Typically, there could be the energisation of very sensitive relays.</i>	N C

Terminal Information – Option Boards			
Terminal Description	Terminal Function	Signal Level	Terminal Number
TERMINAL BLOCK G (SWITCHABLE TACHO CALIBRATION OPTION)			
AC Tacho input	AC		G1
AC Tacho input	AC		G2
+ DC Tacho input	+DC		G3
- DC Tacho input	-DC		G4
Tacho Out	Calibrated Tacho Output		P3
(5701 MICROTACH RECEIVE OPTION - PLASTIC)			
Signal Input	Microtach fibre optic input	There are no other connections to this option module. (The 5701 Microtach should be powered by an external 24V DC at 60mA, 1.4W.)	F1
(5901 MICROTACH OPTION MODULE - GLASS)			
Signal Input	Microtach fibre optic input	There are no other connections to this option module. (The 5901 Microtach should be powered by an external 24V DC at 125mA, 3W.)	F1
TERMINAL BLOCK G (ENCODER OPTION)			
Terminal Block G pinouts will change function depending upon which option board is fitted to the control board. The configuration supplied as standard is with the Switchable Tacho Calibration Option fitted. Further information on the other options may be obtained from the relevant Technical Manual.			
TECHNOLOGY BOX OPTION (SERIAL COMMUNICATIONS)			
Refer to the Technical Manual supplied with the option for details.			

Wiring Requirements for EMC Compliance				
	Power Supply Wire	Motor Wire	External Filter to Converter Wire	Signal/Control Wire
Wire Type (for EMC Compliance)	Unshielded	Shielded/armored	Replace flying leads with shielded/armored when >0.6m	Shielded
Segregation	From all other wiring (clean)	From all other wiring (noisy)		From all other wiring (sensitive)
Length Limitations With External Filter	Unlimited	50 metres	As short as possible	25 metres
Shield to Ground Connection		Both ends	Both ends	Converter end only

11-18 Technical Specifications

Wire Sizes and Termination Tightening Torques (Frames 1, 2, 3, 4 & 5)

Terminations	Maximum Tightening Torque	Recommended Wire Size
All Units		
A1 – A9, B1 – B9, C1 – C9	0.6-0.8Nm (5-7 lb-in.)	14 AWG
Frame 1		
15A, 35A UNITS		
A+, A-, L1, L2, L3	1.8Nm (16 lb-in)	8-18 AWG
Grounding terminal	2.0Nm (17 lb-in.)	12 AWG
F+, F-	0.8Nm (7.0 lb-in)	14 AWG
BL1, BL2, BL3	0.8Nm (7.0 lb-in)	12-22 AWG (Dependent upon fan used)
L, N, 3, 4, TH1, TH2, AUX CONT (TB4)	0.5Nm (5.0 lb-in)	12 AWG
Frame 2		
40A UNITS		
A+, A-	13.5Nm (120 lb-in)	8 AWG
L1, L2, L3	13.5Nm (120 lb-in)	8 AWG
Grounding terminal	13.5Nm (120 lb-in)	6 AWG
FL1, FL2, F-, F+	0.8Nm (7.0 lb-in)	14 AWG
BL1, BL2, BL3	0.8Nm (7.0 lb-in)	6-18 AWG (Dependent upon fan used)
L, N, 3, 4, TH1, TH2, AUX CONT (TB4)	0.5Nm (5.0 lb-in)	12 AWG
70A UNITS		
A+, A-	13.5Nm (120 lb-in)	3 AWG
L1, L2, L3	13.5Nm (120 lb-in)	6 AWG
Grounding terminal	13.5Nm (120 lb-in)	6 AWG
FL1, FL2, F-, F+	0.8Nm (7.0 lb-in)	14 AWG
BL1, BL2, BL3	0.8Nm (7.0 lb-in)	6-18 AWG (Dependent upon fan used)
L, N, 3, 4, TH1, TH2, AUX CONT (TB4)	0.5Nm (5.0 lb-in)	12 AWG
110A UNITS		
A+, A-	13.5Nm (120 lb-in)	1/0 AWG
L1, L2, L3	13.5Nm (120 lb-in)	3 AWG
Grounding terminal	13.5Nm (120 lb-in)	6 AWG
FL1, FL2, F-, F+	0.8Nm (7.0 lb-in)	14 AWG
BL1, BL2, BL3	0.8Nm (7.0 lb-in)	6-18 AWG (Dependent upon fan used)
L, N, 3, 4, TH1, TH2, AUX CONT (TB4)	0.5Nm (5.0 lb-in)	12 AWG
165A UNITS		
A+, A-	42.4Nm (375 lb-in)	4/0 AWG
L1, L2, L3	13.5Nm (120 lb-in)	1/0 AWG
Grounding terminal	13.5Nm (120 lb-in)	3 AWG
FL1, FL2, F-, F+	0.8Nm (7.0 lb-in)	14 AWG
BL1, BL2, BL3	0.8Nm (7.0 lb-in)	6-18 AWG (Dependent upon fan used)
L, N, 3, 4, TH1, TH2, AUX CONT (TB4)	0.5Nm (5.0 lb-in)	12 AWG
Frame 3		
270A UNITS		
A+, A-	11Nm (97 lb-in)	?
L1, L2, L3	11Nm (97 lb-in)	?
Grounding terminal	6.8Nm (60 lb-in)	?
D1- D8, THERM+, THERM-	0.45Nm (4.0 lb-in)	?
BL1, BL2, BL3	?	?
Frame 4 & 5		
380A, 500A, 725A, 830A, 1580A UNITS		
A+, A-	23Nm (204 lb-in)	
L1, L2, L3	23Nm (204 lb-in)	
Grounding terminal	6.8Nm (60 lb-in)	
FL1, FL2, F+, F-	0.8Nm (7 lb-in)	
Auxiliary supply, contactor and motor thermistor	0.6Nm (5 lb-in)	

Termination Tightening Torque (Frame H)

Description	Fixings	Spanner Size	Format	Torque Nm
Drive Mounting Fixings	M12	19mm	Bolt	57.2
Ground studs on back panel	M10	17mm	Nut	32.8
Fuse assy to Phase assy	M10	17mm	Bolt	24
AC Input & DC Output Bus bars	M12	19mm	Nut & Bolt	57.2
Fuse assembly	M12	19mm	Bolt	42
Fuse assembly to CT	M12	19mm	Bolt	42
DC Output terminal panel to side panel	M6	10mm	Bolt	6.8
DC Bus bars	M6	10mm	Nut	6.8
I/P terminal assy	M6	10mm	Nut	4
Lifting Bracket Fixings	M10	17mm	Bolt	24

Cooling Fans

Output Current (armature) (A)	Maximum Rating Ambient ¹ (°C)	Cooling Method	Number of Fans	Fan Power Rating 110/120V ac	Fan Power Rating 220/240V ac
Frame 1					
15	45	no fan	0	N/A	N/A
35	45	Integral Fan	1	N/A	N/A
Frame 2					
40	45	Integral Fan	1	N/A	N/A
70	45	Integral Fan	1	N/A	N/A
110	45	Integral Fan	1	N/A	N/A
165	45	Integral Fan	1	N/A	N/A
Frame 3					
270	45	Integral Fan	1	N/A	N/A
Frame 4					
380	40	Forced Vent 240cfm (410m ³ /hr) @ 200Pa	1	130W, 10μF	140W, 2.5μF
500	40	Forced Vent 240cfm (410m ³ /hr) @ 200Pa	1	130W, 10μF	140W, 2.5μF
725	40	Forced Vent 240cfm (410m ³ /hr) @ 200Pa	1	130W, 10μF	140W, 2.5μF
830	40	Forced Vent 240cfm (410m ³ /hr) @ 200Pa	1	130W, 10μF	140W, 2.5μF
Frame 5					
1580	40	Forced Vent 240cfm (410m ³ /hr) @ 200Pa	2	130W, 10μF (each fan)	140W, 2.5μF (each fan)
Frame H					
1200	40	Separate Fan	2	See note below	See note below
1700	40	Separate Fan	2	See note below	See note below
2200	40	Separate Fan	2	See note below	See note below
2700	40	Separate Fan	2	See note below	See note below
Fans supplied with Frame H units have an air flow rate per fan of 850m ³ /hr at 250 Pascal					
Fan Ratings:					
115V ac 50Hz, 1.67A, 177W, 2750 rpm, motor run capacitor 18μF					
115V ac 60Hz, 2.21A, 240W, 2660 rpm, motor run capacitor 18μF					

11-20 Technical Specifications

Spares List

Frame 1						
Product	Power Board	Terminal Board	Armature Thyristor	Field Bridge	Fan	Fan Assy
591P/0015/220/ 590P/0015/220/	AH470280U101 AH470280U102	AH466407U001 AH466407U001	CF470348 CF470348	CF470349 CF470349	- -	- -
591P/0035/220/ 590P/0035/220/	AH470280U103 AH470280U104	AH466407U001 AH466407U001	CF470348 CF470348	CF470349 CF470349	DL470516 DL470516	LA466464U001 LA466464U001
591P/0015/500/ 590P/0015/500/	AH470280U001 AH470280U002	AH466407U001 AH466407U001	CF470348 CF470348	CF470349 CF470349	- -	- -
591P/0035/500/ 590P/0035/500/	AH470280U003 AH470280U004	AH466407U001 AH466407U001	CF470348 CF470348	CF470349 CF470349	DL470516 DL470516	LA466464U001 LA466464U001

Frame 2						
Product	Power Board	Terminal Board	Armature Thyristor	Field Bridge	Fan	Fan Assy
591P/0040/220/ 590P/0040/220/	AH470330U101* AH470330U102*	- -	CF385522U016 CF385522U016	CF470349 CF470349	DL465313 DL465313	No Sub Assembly No Sub Assembly
591P/0070/220/ 590P/0070/220/	AH470330U101* AH470330U102*	- -	CF385524U016 CF385524U016	CF470349 CF470349	DL465313 DL465313	No Sub Assembly No Sub Assembly
591P/0110/220/ 590P/0110/220/	AH470330U101* AH470330U102*	- -	CF385525U016 CF385525U016	CF470349 CF470349	DL465313 DL465313	No Sub Assembly No Sub Assembly
591P/0165/220/ 590P/0165/220/	AH470330U101* AH470330U102*	- -	CF470523U095 CF470523U095	CF470349 CF470349	DL465313 DL465313	No Sub Assembly No Sub Assembly
591P/0040/500/ 590P/0040/500/	AH470330U001* AH470330U002*	- -	CF385522U016 CF385522U016	CF470349 CF470349	DL465313 DL465313	No Sub Assembly No Sub Assembly
591P/0070/500/ 590P/0070/500/	AH470330U001* AH470330U002*	- -	CF385524U016 CF385524U016	CF470349 CF470349	DL465313 DL465313	No Sub Assembly No Sub Assembly
591P/0110/500/ 590P/0110/500/	AH470330U001* AH470330U002*	- -	CF385525U016 CF385525U016	CF470349 CF470349	DL465313 DL465313	No Sub Assembly No Sub Assembly
591P/0165/500/ 590P/0165/500/	AH470330U001* AH470330U002*	- -	CF470523U095 CF470523U095	CF470349 CF470349	DL465313 DL465313	No Sub Assembly No Sub Assembly

Note: * This PCB is a composite assembly and contains a Power Board, a Terminal Board and a CT Board

Frame 3						
Product	Power Board	Terminal Board	Armature Thyristor	Field Bridge	Fan	Fan Assy
591P/0270/220/ 590P/0270/220/	AH385851U001 AH385851U005	- -	?			
591P/0270/500/ 590P/0270/500/	AH385851U003 AH385851U002	- -				

Frame 4				
Product	Power Board	Suppression Board	Trigger Board	Thyristor
591P/0380/220/ 590P/0380/220/	AH466701U001 AH466701U001	AH466704U001 AH466704U001	AH466703U002 AH466703U002	CF466796U016 CF466796U016
591P/0500/220/ 590P/0500/220/	AH466701U001 AH466701U001	AH466704U001 AH466704U001	AH466703U002 AH466703U002	CF466768U016 CF466768U016
591P/0725/220/ 590P/0725/220/	AH466701U001 AH466701U001	AH466704U001 AH466704U001	AH466703U002 AH466703U002	CF466697U016 CF466697U016
591P/0830/220/ 590P/0830/220/	AH466701U001 AH466701U001	AH466704U001 AH466704U001	AH466703U002 AH466703U002	CF466767U016 CF466767U016
591P/0380/500/ 590P/0380/500/	AH466701U002 AH466701U002	AH466704U001 AH466704U001	AH466703U002 AH466703U002	CF466796U016 CF466796U016
591P/0500/500/ 590P/0500/500/	AH466701U002 AH466701U002	AH466704U001 AH466704U001	AH466703U002 AH466703U002	CF466768U016 CF466768U016
591P/0725/500/ 590P/0725/500/	AH466701U002 AH466701U002	AH466704U001 AH466704U001	AH466703U002 AH466703U002	CF466697U016 CF466697U016
591P/0830/500/ 590P/0830/500/	AH466701U002 AH466701U002	AH466704U001 AH466704U001	AH466703U002 AH466703U002	CF466767U016 CF466767U016
591P/0380/600/ 590P/0380/600/	AH466701U003 AH466701U003	AH466704U002 AH466704U002	AH466703U002 AH466703U002	CF466796U018 CF466796U018
591P/0500/600/ 590P/0500/600/	AH466701U003 AH466701U003	AH466704U002 AH466704U002	AH466703U002 AH466703U002	CF466768U018 CF466768U018
591P/0725/600/ 590P/0725/600/	AH466701U003 AH466701U003	AH466704U002 AH466704U002	AH466703U002 AH466703U002	CF466697U018 CF466697U018
591P/0830/600/ 590P/0830/600/	AH466701U003 AH466701U003	AH466704U002 AH466704U002	AH466703U002 AH466703U002	CF466767U018 CF466767U018

11-22 Technical Specifications

Frame 4				
Product	Field Thyristor	Field Diode	Fan + Capacitor Assembly 115V	Fan + Capacitor Assembly 230V
591P/0380/220/ 590P/0380/220/	CF385522U016	CW464320U016	LA466711U001	LA466711U002
591P/0500/220/ 590P/0500/220/	CF385522U016	CW464320U016	LA466711U001	LA466711U002
591P/0725/220/ 590P/0725/220/	CF385522U016	CW464320U016	LA466711U001	LA466711U002
591P/0830/220/ 590P/0830/220/	CF385522U016	CW464320U016	LA466711U001	LA466711U002
591P/0380/500/ 590P/0380/500/	CF385522U016	CW464320U016	LA466711U001	LA466711U002
591P/0500/500/ 590P/0500/500/	CF385522U016	CW464320U016	LA466711U001	LA466711U002
591P/0725/500/ 590P/0725/500/	CF385522U016	CW464320U016	LA466711U001	LA466711U002
591P/0830/500/ 590P/0830/500/	CF385522U016	CW464320U016	LA466711U001	LA466711U002
591P/0380/600/ 590P/0380/600/	CF385523U018	CW464320U018	LA466711U001	LA466711U002
591P/0500/600/ 590P/0500/600/	CF385523U018	CW464320U018	LA466711U001	LA466711U002
591P/0725/600/ 590P/0725/600/	CF385523U018	CW464320U018	LA466711U001	LA466711U002
591P/0830/600/ 590P/0830/600/	CF385523U018	CW464320U018	LA466711U001	LA466711U002

Frame 5

Product	Power Board	Suppression Board	Trigger Board	Slave Power	Parallel Expansion
591P/1580/220/ 590P/1580/220/	AH466701U001	AH466704U001	AH466703U002	AH466706U011	AH466706U021
591P/1580/500/ 590P/1580/500/	AH466701U002	AH466704U001	AH466703U002	AH466706U012	AH466706U021
591P/1580/600/ 590P/1580/600/	AH466701U003	AH466704U002	AH466703U002	AH466706U013	AH466706U021

Frame 5

Product	Thyristor	Field Thyristor	Field Diode	Fan + Capacitor Assembly 115V	Fan + Capacitor Assembly 230V
591P/1580/220/ 590P/1580/220/	CF466767U016	CF385522U016	CW464320U016	LA466711U001	LA466711U002
591P/1580/500/ 590P/1580/500/	CF466767U016	CF385522U016	CW464320U016	LA466711U001	LA466711U002
591P/1580/600/ 590P/1580/600/	CF466767U018	CF385523U018	CW464320U018	LA466711U001	LA466711U002

Frame H				
Product	Power Board	Trigger Board	Suppression Board	Snubber Board
591P/1200/500/ 590P/1200/500/	AH466001U101 AH466001U101	AH466003U001 AH466003U001	AH466003U003	AH466004U001 AH466004U001
591P/1700/500/ 590P/1700/500/	AH466001U101 AH466001U101	AH466003U001 AH466003U001	AH466003U003	AH466004U001 AH466004U001
591P/2200/500/ 590P/2200/500/	AH466001U101 AH466001U101	AH466003U101 AH466003U101	AH466003U103	AH466004U101 AH466004U101
591P/2700/500/ 590P/2700/500/	AH466001U101 AH466001U101	AH466003U101 AH466003U101	AH466003U103	AH466004U101 AH466004U101
591P/1200/690/ 590P/1200/690/	AH466001U001 AH466001U001	AH466003U002 AH466003U002	AH466003U004	AH466004U002 AH466004U002
591P/1700/690/ 590P/1700/690/	AH466001U001 AH466001U001	AH466003U002 AH466003U002	AH466003U004	AH466004U002 AH466004U002
591P/2200/690/ 590P/2200/690/	AH466001U001 AH466001U001	AH466003U102 AH466003U102	AH466003U104	AH466004U102 AH466004U102
591P/2700/690/ 590P/2700/690/	AH466001U001 AH466001U001	AH466003U102 AH466003U102	AH466003U104	AH466004U102 AH466004U102

Frame H				
Product	Field Assembly	Phase Assembly	Fuses	Fan 110V
591P/1200/500/ 590P/1200/500/	LA466730U001 LA466730U001	LA466059U012 LA466059U012	CS466260U050 CS466261U035	DL466242 DL466242
591P/1700/500/ 590P/1700/500/	LA466730U001 LA466730U001	LA466059U017 LA466059U017	CS466260U080 CS466261U055	DL466242 DL466242
591P/2200/500/ 590P/2200/500/	LA466730U001 LA466730U001	LA466059U022 LA466059U022	CS466260U100 CS466261U070	DL466242 DL466242
591P/2700/500/ 590P/2700/500/	LA466730U001 LA466730U001	LA466059U027 LA466059U027	CS466260U125 CS466261U090	DL466242 DL466242
591P/1200/690/ 590P/1200/690/	LA466730U002 LA466730U002	LA466059U112 LA466059U112	CS466260U050 CS466261U035	DL466242 DL466242
591P/1700/690/ 590P/1700/690/	LA466730U002 LA466730U002	LA466059U117 LA466059U117	CS466260U080 CS466261U055	DL466242 DL466242
591P/2200/690/ 590P/2200/690/	LA466730U002 LA466730U002	LA466059U122 LA466059U122	CS466260U100 CS466261U070	DL466242 DL466242
591P/2700/690/ 590P/2700/690/	LA466730U002 LA466730U002	LA466059U127 LA466059U127	CS466260U125 CS466261U090	DL466242 DL466242

CERTIFICATION FOR THE CONVERTER

Caution

The integration of this product into other apparatus or systems is not the responsibility of Eurotherm Drives, with respect to applicability, effectivity, or safety of operation of the other apparatus or systems.

Requirements for EMC Compliance

All Variable Speed Drives (VSDs) potentially produce electrical emissions which are radiated into the environment and conducted back into the ac supply. VSDs are inherently immune to any additional external electrical noise. The following information is provided to maximise the Electro Magnetic Compatibility (EMC) of VSDs and systems in their intended operating environment, by minimising their emissions and maximising their immunity.

Minimising Radiated Emissions

EN55011/EN55022 radiated emission measurements are made between 30MHz and 1GHz in the far field at a distance of 10 to 30 metres (32.8 to 98.4 feet). Limits lower than 30MHz or in close proximity are not specified. Emissions from individual components tend to be additive.

- Use a screened/armoured cable between VSD/cubicle and motor containing the motor protective earth (PE) connection. It should have a 360° screen termination. Earth screen at both ends connecting to the motor frame and VSD/cubicle backplate. Maintain the screen integrity using 360° terminations.

Note: Some hazardous area installations may preclude direct earthing at both ends of the screen, in this case earth one end via a 1 μ F 50Vac capacitor, and the other must be directly earthed.

- Keep unshielded cable as short as possible inside the cubicle.
- Always maintain the integrity of the shield.
- If the cable is interrupted to insert contactors etc., re-connect the screen using the shortest possible route.
- Keep the length of screen stripped-back as short as possible when making screen connections.
- Ideally use 360° screen terminations using cable glands or 'U' clips on power screen rails.

If a shielded cable is not available, lay unshielded motor cables in a metal conduit which will act as a shield. The conduit must be continuous with a direct electrical contact to the VSD and motor housing. If links are necessary, use braid with a minimum cross sectional area of 10mm².

Note: Some motor gland boxes, conduit and conduit glands are made of plastic, if this is the case, then braid must be connected in parallel to maintain screen integrity. In addition at the motor end, ensure that the screen is electrically connected to the motor frame since some terminal boxes are insulated from the frame by gasket/paint.

Earthing Requirements

IMPORTANT: Protective earthing always takes precedence over EMC earthing.

Protective Earth (PE) Connections

Note: In accordance with installations to EN60204, only one protective earth conductor is permitted at each VSD protective earth terminal contacting point.

Local wiring regulations may require the protective earth connection of the motor to be connected locally, i.e. not as specified in these instructions. This will not cause shielding problems because of the relatively high RF impedance of the local earth connection.

12-2 Certification for the Converter

Control/Signal EMC Earth Connections

For compliance with EN60204 and EMC requirements, the “0V/signal ground” must be separately earthed. When a number of units are used in a system, these terminals should be connected together at a single, local earthing point.

Control and signal cables for the encoder, all analogue inputs, and communications require screening with the screen connected only at the VSD end. However, if high frequency noise is still a problem, earth screen at the non VSD end via a 0.1µF, 50Vac capacitor.

Note: Connect the screen (at the VSD end) to the VSD protective point, and not to the control board terminals.

Cabling Requirements

Note: Refer to Chapter 11: “Technical Specifications” for additional Cabling Requirements.

Planning Cable Runs

- Use the shortest possible motor cable lengths.
- Keep electrically noisy and sensitive cables apart.
- Keep electrically noisy and sensitive parallel cable runs to a minimum. Separate parallel cable runs by at least 0.25 metres (0.8 feet). For runs longer than 10 metres (32.8 feet), separation should be increased proportionally. For example if the parallel runs were 50m (164 feet), then the separation would be $(50/10) \times 0.25\text{m} = 1.25\text{m}$ ($164/32.8 \times 0.8 = 4$ feet).
- Sensitive cables should cross noisy cables at 90°.
- Never run sensitive cables close or parallel to the motor cable for any distance.
- Never run supply or motor cables in the same bundle as the signal/control and feedback cables, even if they are screened.
- Ensure EMC filter input and output cables are separately routed and do not couple noise across the filter (i.e. bypass the filter).

Increasing Motor Cable Length

Because cable capacitance and hence conducted emissions increase with motor cable length, conformance to EMC limits is only guaranteed with the specified ac supply filter option using a maximum cable length as specified in Chapter 11: “Technical Specifications”.

Screened/armoured cable has significant capacitance between the conductors and screen which increases linearly with cable length (typically 200pF/m but varies with cable type and current rating).

Long cable lengths may have the following undesirable effects:

- Producing increased conducted emissions which degrade the performance of the EMC filter due to saturation.
- Causing RCDs (Residual Current Devices) to trip due to increased high frequency earth current.
- Producing increased heating inside the EMC ac supply filter from the increased conducted emissions.

These effects can be overcome by adding chokes at the output of the VSD.

EMC Installation Options

The unit, when installed for Class A operation, will be compliant with EN55011 (1991)/EN55022 (1994) for radiated emissions, as described below.

Screening & Earthing (cubicle mounted, Class A)

Note: The installation requirements of local safety standards must be achieved regarding the safety of electrical equipment for machines.

The unit is installed for Class A operation when mounted inside a cubicle having 10dB attenuation between 30 and 100MHz (typically the attenuation provided by a metal cabinet with no aperture of dimension greater than 0.15m (0.5 feet), using the recommended ac supply filter and having met all cabling requirements.

Note: Radiated magnetic and electric fields inside the cubicle will be high and any components fitted inside must be sufficiently immune.

The VSD, external filter and associated equipment are mounted on to a conducting, metal mounting panel. Do not use cubicle constructions that use insulating mounting panels or undefined mounting structures. Cables between the VSD and motor must be screened or armoured and terminated at the VSD or locally on the back panel.

Single VSD - Single Motor

Apply a single point series earthing strategy for a single VSD mounted in a cubicle as shown.

The protective earth connection (PE) to the motor must be run inside the screened cable between the motor and VSD and be connected to a separate star point earth terminal near the VSD.

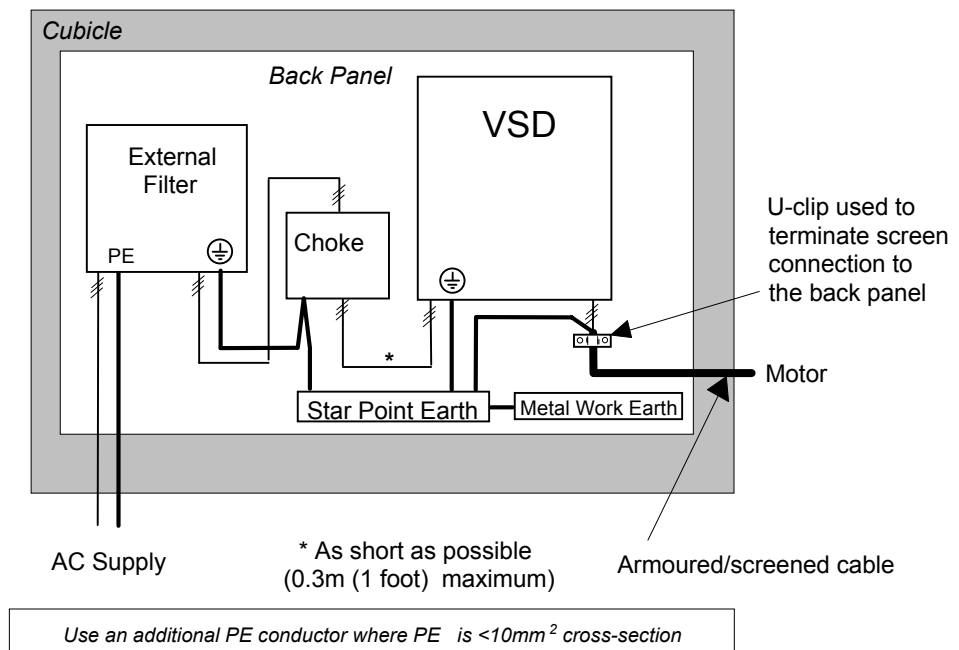

Figure 12-1 EMC and Safety Earthing Cabling

12-4 Certification for the Converter

Star Point Earthing

A star-point earthing policy separates 'noisy' and 'clean' earths. Four separate earth busbars (three are insulated from the mounting panel) connect to a single earth point (star point) near the incoming safety earth from the main supply. Flexible, large cross-section cable is used to ensure a low HF impedance. Busbars are arranged so that connection to the single earth point is as short as possible.

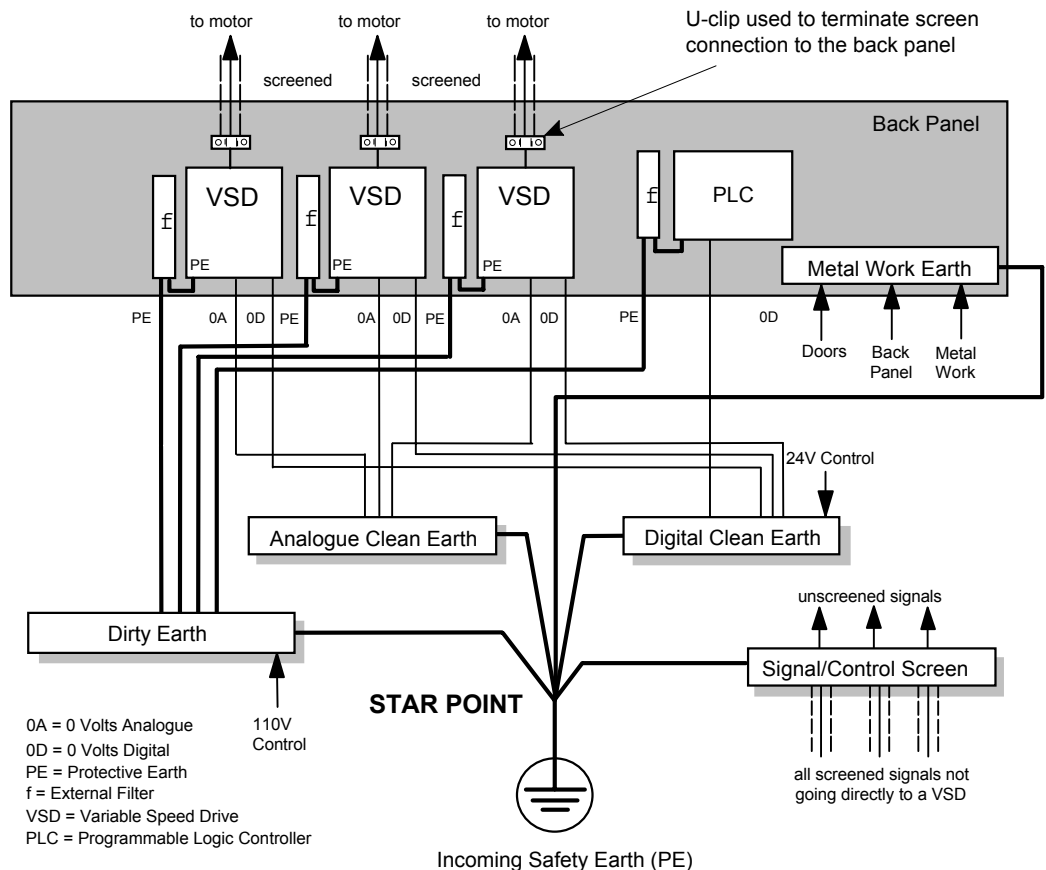

Figure 12-2 Star Point Earthing

1 Clean Earth Busbar (insulated from the mounting panel)

Used as a reference point for all signal and control cabling. This may be further subdivided into an analogue and a digital reference busbar, each separately connected to the star earthing point. The digital reference is also used for any 24V control.

2 Dirty Earth Busbar (insulated from the mounting panel)

Used for all power earths, i.e. protective earth connection. It is also used as a reference for any 110 or 220V control used, and for the control transformer screen.

3 Metal Work Earth Busbar

The back panel is used as this earth busbar, and should provide earthing points for all parts of the cubicle including panels and doors. This busbar is also used for power screened cables which terminate near to (10cm/4 inches) the VSD - such as motor cables, braking choppers and their resistors, or between VSDs. Use U-clips to clamp the screened cables to the back panel to ensure optimum HF connection.

4 Signal/Control Screen Earth Busbar (insulated from the mounting panel)

Used for signal/control screened cables which **do not** go directly to the VSD. Place this busbar as close as possible to the point of cable entry. 'U' clamp the screened cables to the busbars to ensure an optimum HF connection.

Sensitive Equipment

The proximity of the source and victim circuit has a large effect on radiated coupling. The electromagnetic fields produced by VSDs falls off rapidly with distance from the cabling/cubicle. Remember that the radiated fields from EMC compliant drive systems are measured at least 10m from the equipment, over the band 30-1000MHz. Any equipment placed closer than this will see larger magnitude fields, especially when very close to the Converter.

Do not place magnetic/electric field sensitive equipment within 0.25 metres (0.8 feet) of the following parts of the VSD system:

- Variable Speed Drive (VSD)
- Input or output chokes/transformers
- The cable between VSD and motor (even when screened/armoured)
- AC/DC brushed motors (due to commutation)
- Relays and contactors (even when suppressed)

From experience, the following equipment is particularly sensitive and requires careful installation.

- Any transducers which produce low level analogue outputs (<1V) , e.g. load cells, strain gauges, thermocouples, piezoelectric transducers, anemometers, LVDTs
- Wide band width control inputs (>100Hz)
- AM radios (long and medium wave only)
- Video cameras and closed circuit TV
- Office personal computers
- Capacitive devices such as proximity sensors and level transducers
- Mains borne communication systems
- Equipment not suitable for operation in the intended EMC environment, i.e. with insufficient immunity to new EMC standards

Requirements for UL Compliance

Motor Overload Protection

Note: An external motor overload protective device must be provided by the installer.

The maximum internal overload protection level (current limit) is 150% for 30 seconds and 200% for 10 seconds.

Motor overload protection is provided by means of the thermal device in the motor winding. This protection cannot be evaluated by UL, hence it is the responsibility of the installer and/or the local inspector to determine whether the overload protection is in compliance with the National Electrical Code or Local Code requirements.

Branch Circuit/Short Circuit Protection Requirements

The controller requires branch circuit protection. Branch circuit protection requirements must be in accordance with the latest addition of the National Electrical Code, NEC/NFPA-70.

UL Recognized Component (JFHR2) semiconductor fuses with current ratings and maximum I^2t ratings as specified below must be used in the controller. Refer to the table below for the recommended fuse manufacturer and part number.

(HP) 500V	Controller Rating (A)	Input Line Semiconductor Fuses				Part No. Gould or equivalent*
		Ratings			Part No. Gould or equivalent*	
		(Vac)	(A)	I^2t (A ² s)		
7.5	15	500	31.3	750	A60Q35	
20	35	500	31.3	750	A60Q35	
20	40	500	31.3	750	A60Q35	
30	70	500	71.6	1300	A50QS80-4R	
40	70	500	71.6	1300	A50QS80-4R	
50	110	500	111.8	2860	A50QS125-4R	
60	110	500	111.8	2860	A50QS125-4R	
75	165	500	156.6	7540	A50QS175-4R	
100	165	500	156.5	7540	A50QS175-4R	
					Part No. Bussmann or equivalent*	
200	380	660	550	135000	170M6809	
300	500	660	700	300000	170M6811	
400	725	660	900	670000	170M6813	
500	830	660	1000	945000	170M6814	
900	1580	660	2 x 1000	945000	170M6814	
<p>* Other UL Recognized Component (JFHR2) semiconductor fuses may be used in the controller provided that the voltage, ampere and I^2t ratings shown above are not exceeded.</p> <p>Note: Semiconductor fuses are acceptable as branch circuit short-circuit protection for the solid-state motor controllers only.</p>						

Table 12-1 Short Circuit Protection Requirements

Short Circuit Ratings

These products are suitable for use on a circuit capable of delivering not more than (the value shown in Table 12-2) RMS Symmetrical Amperes, 500V maximum.

Output Ratings		Short Circuit Rating RMS Symmetrical Amperes
(A)	(kW) 500V	
15	7.5	5,000
35	15	5,000
40	15	10,000
70	30	10,000
110	45	10,000
165	75	10,000
380	150	18000
500	225	18000
725	327	30000
830	335	30000
1580	650	85000

Table 12-2 Short Circuit Ratings

Field Wiring Temperature Rating

Use 75°C copper conductors only.

Operating Ambient Temperature

For the operating ambient temperature range, refer to Chapter 11: “Technical Specifications”.

Field Wiring Terminal Markings

For the correct field wiring connections that are to be made to each terminal, refer to Chapter 3: “Installing the Converter” - Electrical Installation.

Power and Control Field Wiring Terminals

For the correct tightening torque value, refer to Chapter 11: “Technical Specifications”.

Field Grounding Terminals

The field grounding terminal(s) is identified with the International Grounding Symbol (IEC) Publication 417, Symbol 5019.



Field Terminal Kits

UL compliant terminal kits are available for the connection of power wiring for the following Converter ratings. These terminals must be applied with the correct tooling as described in the Installation Instructions provided with each terminal kit.

Kit Part Number	Controller Rating (A)	Number of Lugs	Purpose	Lugs per Terminal	Wire Size per Lug	Cable Rating
LA386000U380	380	3	AC	1	2 x 4/0 AWG	230A
		2	DC	1	2 x 250kcmil	255A
LA386000U500	500	3	AC	1	2 x 300kcmil	285A
		2	DC	1	2 x 350kcmil	310A
LA386000U725	725	3	AC	1	2 x 600kcmil	420A
		4	DC	2	2 x 4/0 AWG	230A
LA386000U830	830	6	AC	2	2 x 250kcmil	255A
		4	DC	2	2 x 300kcmil	285A

Note: 1580A controller requires two LA386000U830 kits.

Fuse Replacement Information

For fuse replacement information, refer to Chapter 11: “Technical Specifications”.

12-8 Certification for the Converter

Recommended Wire Sizes (Frames 1, 2, 4 & 5)

Main power wiring. Local wiring regulations always take precedence.

Drive Size (A)	Input Current (A)	Input			Output	
		Number of Conductors	North American Wire Size	Output Current (A)	Number of Conductors	North American Wire Size
Frame 1						
15	13.5	1	12 AWG	15	1	12 AWG
35	28.35	1	8 AWG	35	1	8 AWG
Frame 2						
40	36	1	8 AWG	40	1	8 AWG
70	63	1	1 AWG	70	1	3 AWG
110	99	1	1 AWG	110	1	1/0 AWG
165	148.5	1	3/0 AWG	165	1	4/0 AWG
Frame 4 & 5						
380	342	1	700 Kcmil	380	1	750 Kcmil
500	450	1	1250 Kcmil	500	1	1500 Kcmil
725	653	1	3 inch bus bar	725	1	3 inch bus bar
830	747	1	3 inch bus bar	830	1	4 inch bus bar
1580	1427	2	4 inch bus bar	1580	2	4 inch bus bar

Recommended Wire Sizes (Frame H)

Local wiring regulations always take precedence.

Description	Drive Size (A)	Input			Output		
		Input Current (A)	Number of Conductors	North American Wire Size	Output Current (A)	Number of Conductors	North American Wire Size
Main Power	1200	1100	4	500	1200	4	500
	1700	1550	6	400	1700	6	500
	2200	2000	6	600	2200	6	700
	2700	2450	6	900	2700	8	700
Field	60	60	1	AWG 8	60	1	AWG 8

European Directives and the CE Mark

The following information is supplied to provide a basic understanding of the EMC and low voltage directives CE marking requirements. The following literature is recommended for further information:

- *Recommendations for Application of Power Drive Systems (PDS), European Council Directives - CE Marking and Technical Standardisation - (CEMEP)*
Available from your local trade association or Eurotherm Drives office
- *EMC Installation Guidelines for Modules and Systems - (Eurotherm Drives)*
Available from your local Eurotherm Drives office, part number HA388879
- *Short Form Overview of European Directives for Variable Speed Drives and Applications - (Eurotherm Drives)*
Available from your local Eurotherm Drives office, part number HA389770

The European machines and drives manufacturers via their national trade associations have formed the European Committee of Manufacturers of Electrical Machines and Power Electronics (CEMEP). Eurotherm Drives and other major European drives manufacturers are working to the CEMEP recommendations on CE marking. The CE mark shows that a product complies with the relevant EU directives, in our case the Low Voltage Directive and, in some instances, the EMC Directive.

CE Marking for Low Voltage Directive

When installed in accordance with this manual, the 590+ Series Converter is CE marked by Eurotherm Drives Ltd in accordance with the low voltage directive (S.I. No. 3260 implements this LVD directive into UK law). An EC Declaration of Conformity (low voltage directive) is included at the end of this chapter.

CE Marking for EMC - Who is Responsible?

Note: *The specified EMC emission and immunity performance of this unit can only be achieved when the unit is installed to the EMC Installation Instructions given in this manual.*

According to S.I. No. 2373 which implements the EMC directive into UK law, the requirement for CE marking this unit falls into two categories:

1. Where the supplied unit has an intrinsic/direct function to the end user, then the unit is classed as **relevant apparatus**.
2. Where the supplied unit is incorporated into a higher system/apparatus or machine which includes (at least) the motor, cable and a driven load but is unable to function without this unit, then the unit is classed as a **component**.

■ **Relevant Apparatus - Eurotherm Drives Responsibility**

Occasionally, say in a case where an existing fixed speed motor - such as a fan or pump - is converted to variable speed with an add-on drive module (*relevant apparatus*), it becomes the responsibility of Eurotherm Drives to apply the CE mark and issue an EC Declaration of Conformity for the EMC Directive. This declaration and the CE mark is included at the end of this chapter.

■ **Component - Customer Responsibility**

The majority of Eurotherm Drives' products are classed as *components* and therefore we cannot apply the CE mark or produce an EC Declaration of Conformity in respect of EMC. It is therefore the manufacturer/supplier/installer of the higher system/apparatus or machine who must conform to the EMC directive and CE mark.

Legal Requirements for CE Marking

IMPORTANT: Before installation, clearly understand who is responsible for conformance with the EMC directive. Misappropriation of the CE mark is a criminal offence.

It is important that you have now defined who is responsible for conforming to the EMC directive, either:

■ Eurotherm Drives Responsibility

You intend to use the unit as *relevant apparatus*.

When the specified EMC filter is correctly fitted to the unit following EMC installation instructions, it complies with the relevant standards indicated in the following tables. The fitting of the filter is mandatory for the CE marking of this unit to apply.

The relevant declarations are to be found at the end of this chapter. The CE mark is displayed on the EC Declaration of Conformity (EMC Directive) provided at the end of this chapter.

■ Customer Responsibility

You intend to use the unit as a *component*, therefore you have a choice:

1. To fit the specified filter following EMC installation instructions, which may help you gain EMC compliance for the final machine/system.
2. Not to fit the specified filter, but use a combination of global or local filtering and screening methods, natural migration through distance, or the use of distributed parasitic elements of the existing installation.

Note: *When two or more EMC compliant components are combined to form the final machine/system, the resulting machine/system may no longer be compliant, (emissions tend to be additive, immunity is determined by the least immune component). Understand the EMC environment and applicable standards to keep additional compliance costs to a minimum.*

Applying for CE Marking for EMC

We have supplied a Manufacturer's EMC Declaration at the end of this chapter that you can use as a basis for your own justification of overall compliance with the EMC directive. There are three methods of demonstrating conformity:

1. Self-certification to a relevant standard
2. Third party testing to a relevant standard
3. Writing a technical construction file stating the technical rationale as to why your final machine/system is compliant. An EMC "competent body" must then assess this and issue a technical report or certificate to demonstrate compliance.
Refer to Article 10(2) of Directive 89/336/EEC.

With EMC compliance, an EC Declaration of Conformity and the CE mark will be issued for your final machine/system.

IMPORTANT: **Professional end users with EMC expertise who are using drive modules and cubicle systems defined as components who supply, place on the market or install the relevant apparatus must take responsibility for demonstrating EMC conformance and applying the CE mark and issuing an EC Declaration of Conformity.**

Which Standards Apply?

Basic and Generic Standards

The standards that may apply to this unit come under two broad categories:

1. Emission - these standards limit the interference caused by operating (this) drive module.
2. Immunity - these standards limit the effect of interference (on this unit) from other electrical and electronic apparatus.

The following table indicates the standards that the unit may comply with, dependent upon how it is installed and used.

Assuming installation to EMC instructions in this manual

“Filter” refers to a specified external filter.

Installation	Basic and Generic Standards	Unit used as <i>Relevant Apparatus</i>		Unit used as a <i>Component</i>		
		filter <i>(EMC compliance)</i>	no filter	filter <i>(EMC compliance may be applied for)</i>	no filter	
		enclosure	enclosure	enclosure	enclosure	
Industrial 	Radiated RF Emission	EN55011 Class A (1991) or EN50081-2 (1994)	✓	✓	✓	✓
	Conducted RF Emission	EN55011 Class A (1991) or EN50081-2 (1994)	✓		✓	
	Immunity	EN50082-2 (1995)	✓	✓	✓	✓

Table 12-1 Applicable Basic and Generic Standards

12-12 Certification for the Converter

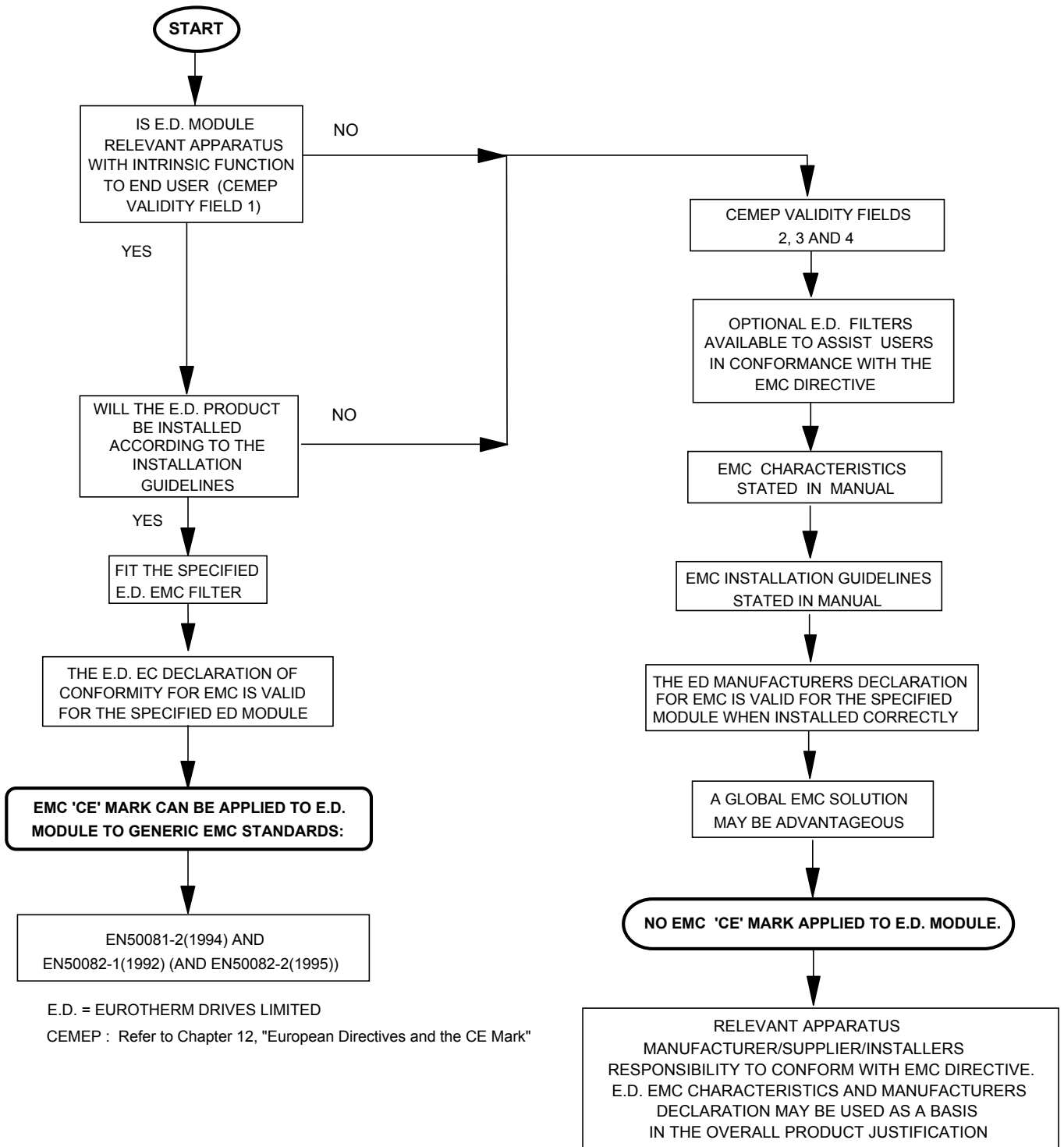

Figure 12-3 Eurotherm EMC 'CE' Mark Validity Chart

Certificates

590+



EC DECLARATIONS OF CONFORMITY

Date CE marked first applied: 01.01.2000

EMC Directive

In accordance with the EEC Directive 89/336/EEC and amended by 92/31/EEC and 93/68/EEC, Article 10 and Annex 1, (EMC DIRECTIVE)

We Eurotherm Drives Limited, address as below, declare under our sole responsibility that the above Electronic Products when installed and operated with reference to the instructions in the Product Manual (provided with each piece of equipment) is in accordance with the relevant clauses from the following standards:- BSEN50081-2 (1994), BSEN50082-1# (1992) and EN50082-2#* (1995)

Low Voltage Directive

In accordance with the EEC Directive 73/23/EEC and amended by 93/68/EEC, Article 13 and Annex III, (LOW VOLTAGE DIRECTIVE)

We Eurotherm Drives Limited, address as below, declare under our sole responsibility that the above Electronic Products when installed and operated with reference to the instructions in the Product Manual (provided with each piece of equipment), is in accordance with the relevant clauses from the following standard :- EN50178 (1998)

Issued for compliance with the EMC Directive when the unit is used as *relevant apparatus*.

The drive is CE marked in accordance with the low voltage directive for electrical equipment and appliances in the voltage range when installed correctly.

MANUFACTURERS DECLARATIONS

EMC Declaration

We Eurotherm Drives Limited, address as below, declare under our sole responsibility that the above Electronic Products when installed and operated with reference to the instructions in the Product Manual (provided with each piece of equipment) is in accordance with the relevant clauses from the following standards:- BSEN50081-2 (1994), BSEN50082-1# (1992) and EN50082-2#* (1995)

Machinery Directive

The above Electronic Products are components to be incorporated into machinery and may not be operated alone. The complete machinery or installation using this equipment may only be put into service when the safety considerations of the Directive 89/392/EEC are fully adhered to. Particular reference should be made to EN60204-1 (Safety of Machinery - Electrical Equipment of Machines). All instructions, warnings and safety information of the Product Manual must be adhered to.

This is provided to aid your justification for EMC compliance when the unit is used as a *component*.

Since the potential hazards are mainly electrical rather than mechanical, the drive does not fall under the machinery directive. However, we do supply a manufacturer's declaration for when the drive is used (as a *component*) in machinery.

Dr Martin Payn (Conformance Officer)

* For information only
Compliant with these immunity standards without specified EMC filters.

EUROTHERM DRIVES LIMITED

NEW COURTWICK LANE, LITTLEHAMPTON, WEST SUSSEX BN17 7RZ
TELEPHONE: 01903 737000 FAX: 01903 737100

Registered Number: 1159876 England. Registered Office: Southdownview Way, Worthing, West Sussex BN14 8NN

File Name: P:\CE\SAFETY\PRODUCTS\590\590+\PRODFILE\HK466403.919 © 1999 EUROTHERM DRIVES LIMITED

ISS:	DATE	DRN: MP	CHKD:	DRAWING NUMBER: HK466403.919	
A	21.09.99			TITLE:	SHT 1 OF 1 SHTS
				Declarations of Conformity	

12-14 Certification for the Converter

STANDARD AND OPTIONAL EQUIPMENT

Standard Equipment

Power Board Circuit Descriptions

AH470280U001, U002, U003, U004 (Frame 1)

(2 Quad and 4 Quad)

Power supplies for the controller are generated from the single phase auxiliary supply via a Switched Mode Power Supply. The incoming supply is directly rectified to provide a high voltage dc power rail. A high voltage transistor switches this rail on to the primary of a high frequency transformer, the output of which is rectified and smoothed to provide the dc power supply rails. The +15V dc rail is monitored via a reference element and a control signal returned via an opto-isolator to the control element of the high voltage switching transistor. The other dc rails (-15V & +24V dc) are generated via separate secondary windings which are rectified and smoothed, with a separate SMPS element providing a regulated +5V dc rail. The SMPS operates over an input voltage range of 110V to 240V ac $\pm 10\%$, 50/60Hz.

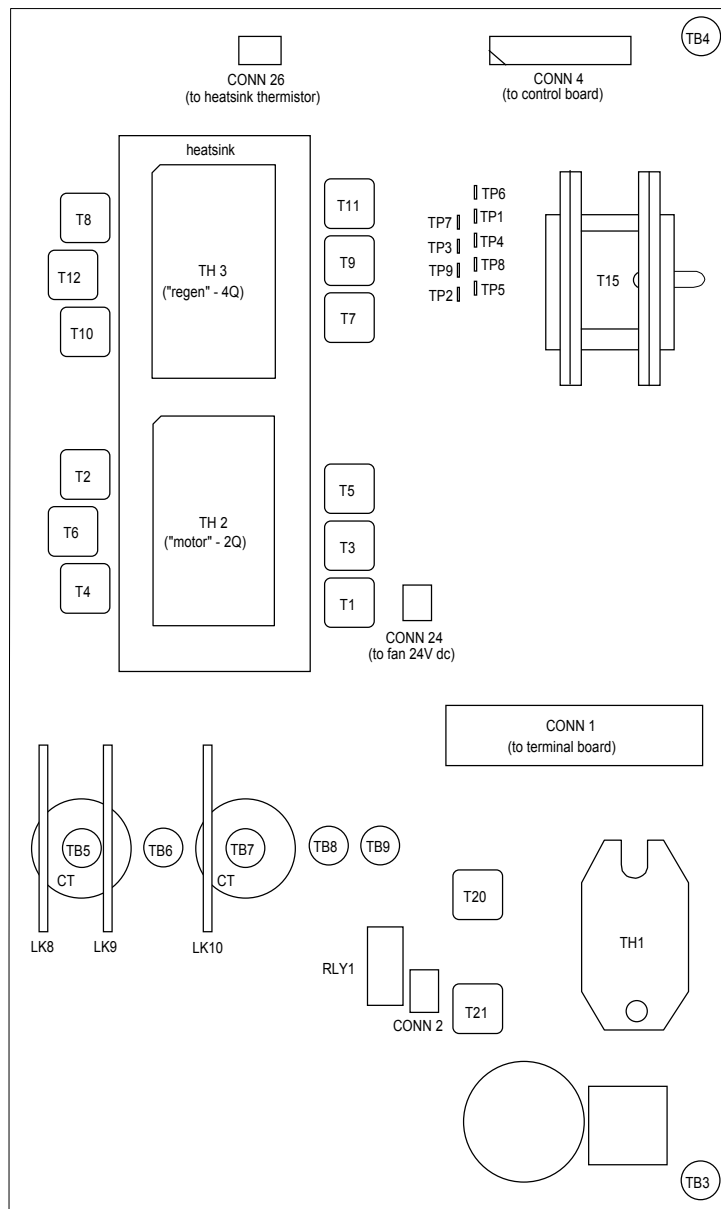

Figure 13-1 590+ Power Board 4 Quad (AH470280U001, U002, U003, U004)

13-2 Standard and Optional Equipment

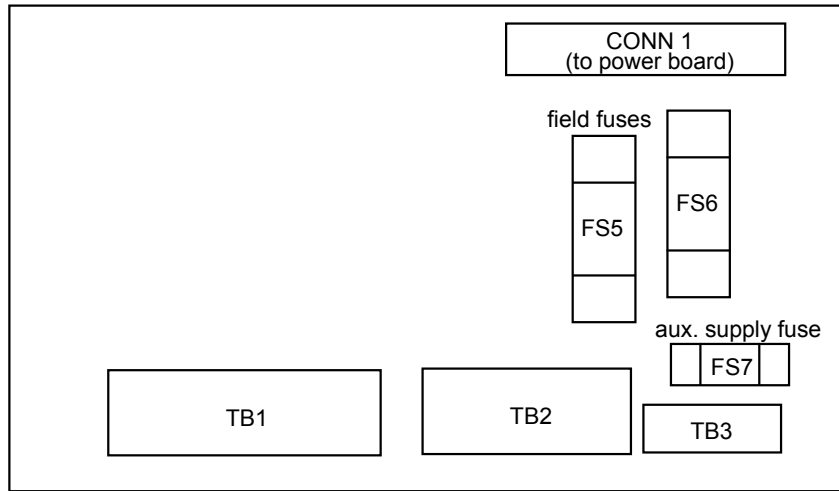

Figure 13-2 Terminal Board - AH466407 (Frame 1)

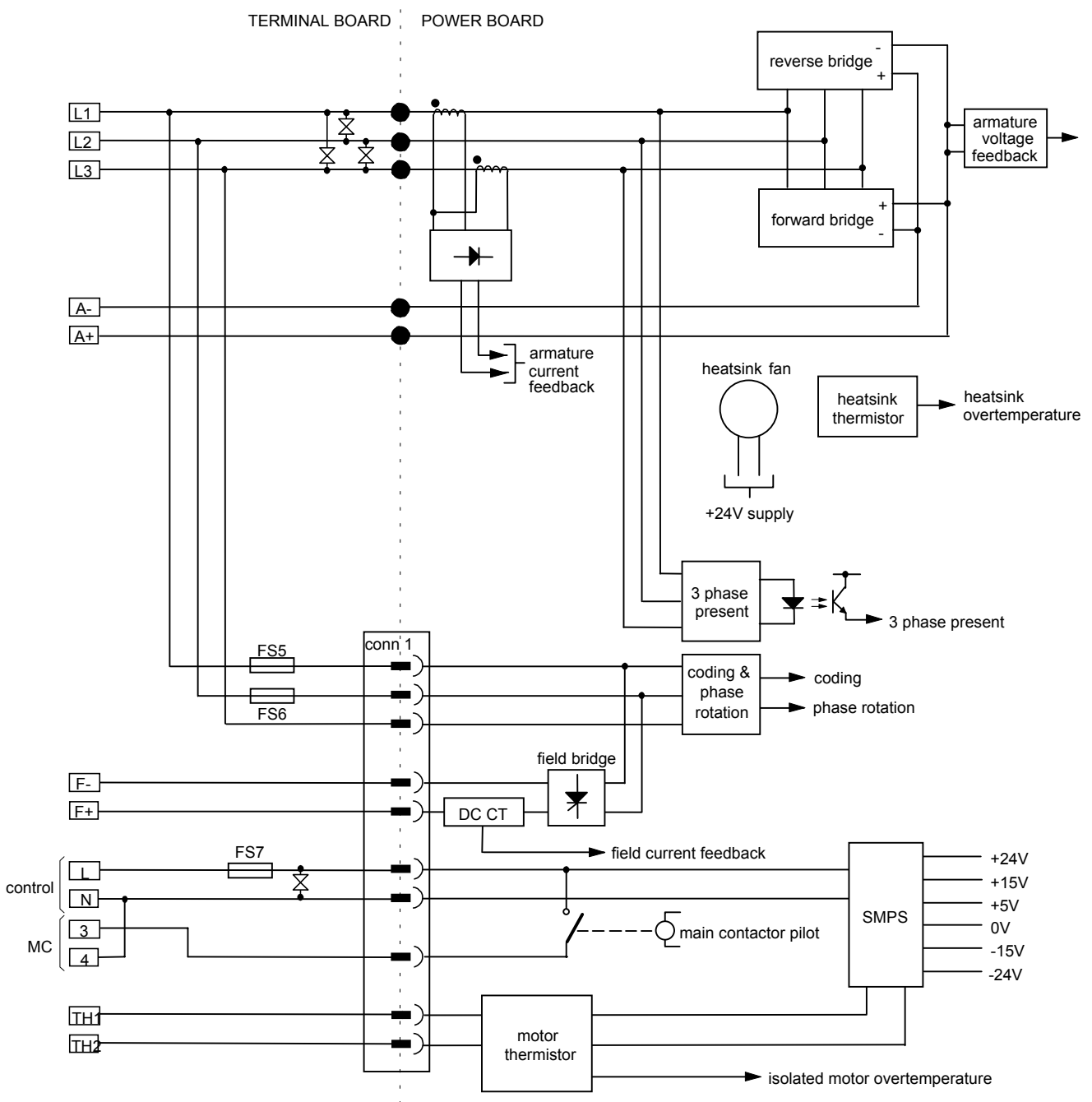

Figure 13-3 Connection Diagram for Power Board and Terminal Board - AH470280 (Frame 1)

AH470330 (Frame 2)

(2 Quad and 4 Quad)

Power supplies for the controller are generated from the single phase auxiliary supply via a Switched Mode Power Supply. The incoming supply is directly rectified to provide a high voltage dc power rail. A high voltage transistor switches this rail on to the primary of a high frequency transformer, the output of which is rectified and smoothed to provide the dc power supply rails. The +15V dc rail is monitored via a reference element and a control signal returned via an opto-isolator to the control element of the high voltage switching transistor. The other dc rails (-15V & +24V dc) are generated via separate secondary windings which are rectified and smoothed, with a separate SMPS element providing a regulated +5V dc rail. The SMPS operates over an input voltage range of 110V to 240V ac $\pm 10\%$, 50/60Hz.

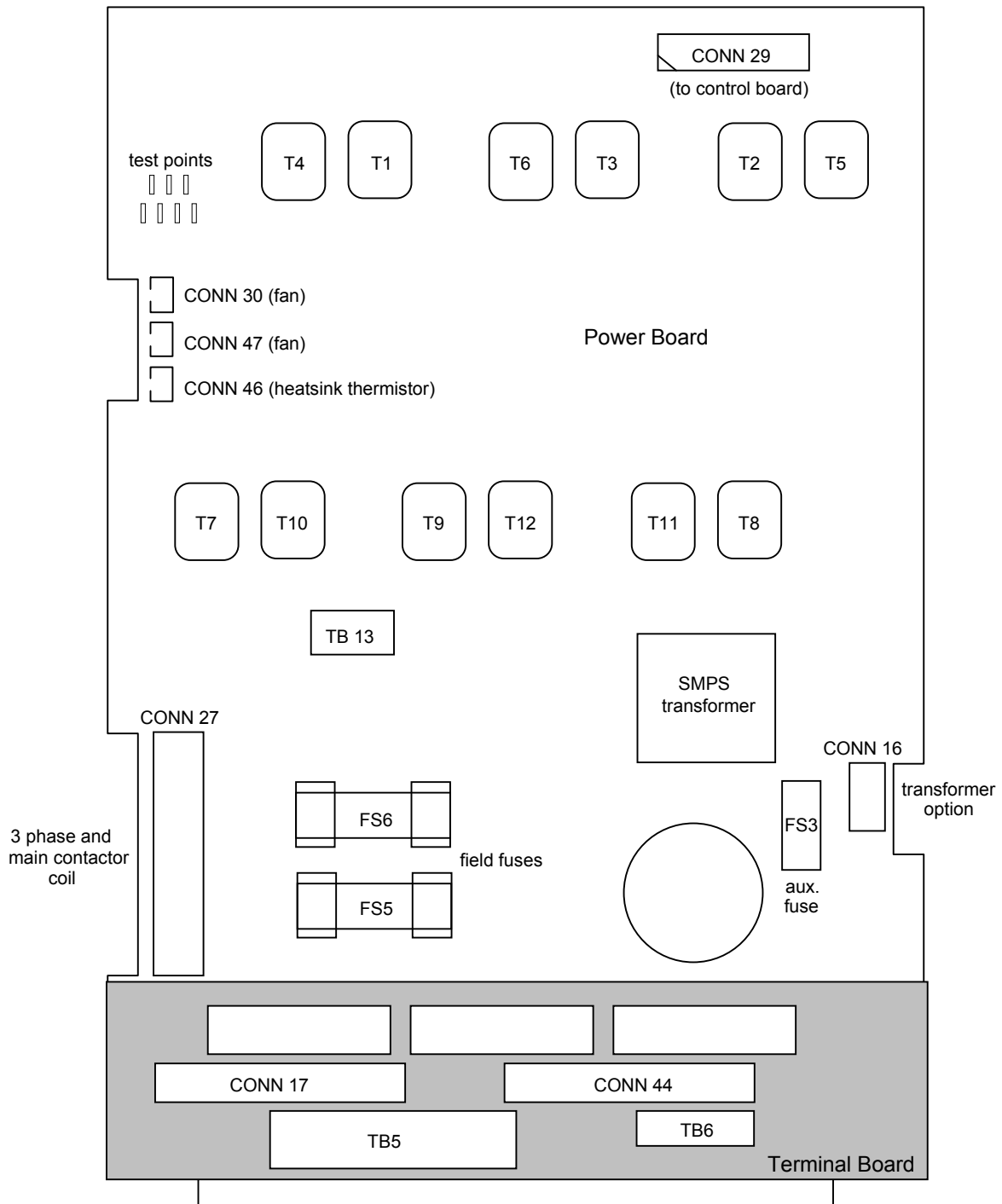

Figure 13-4 590+ Power Board 4 Quad (AH470330)

13-4 Standard and Optional Equipment

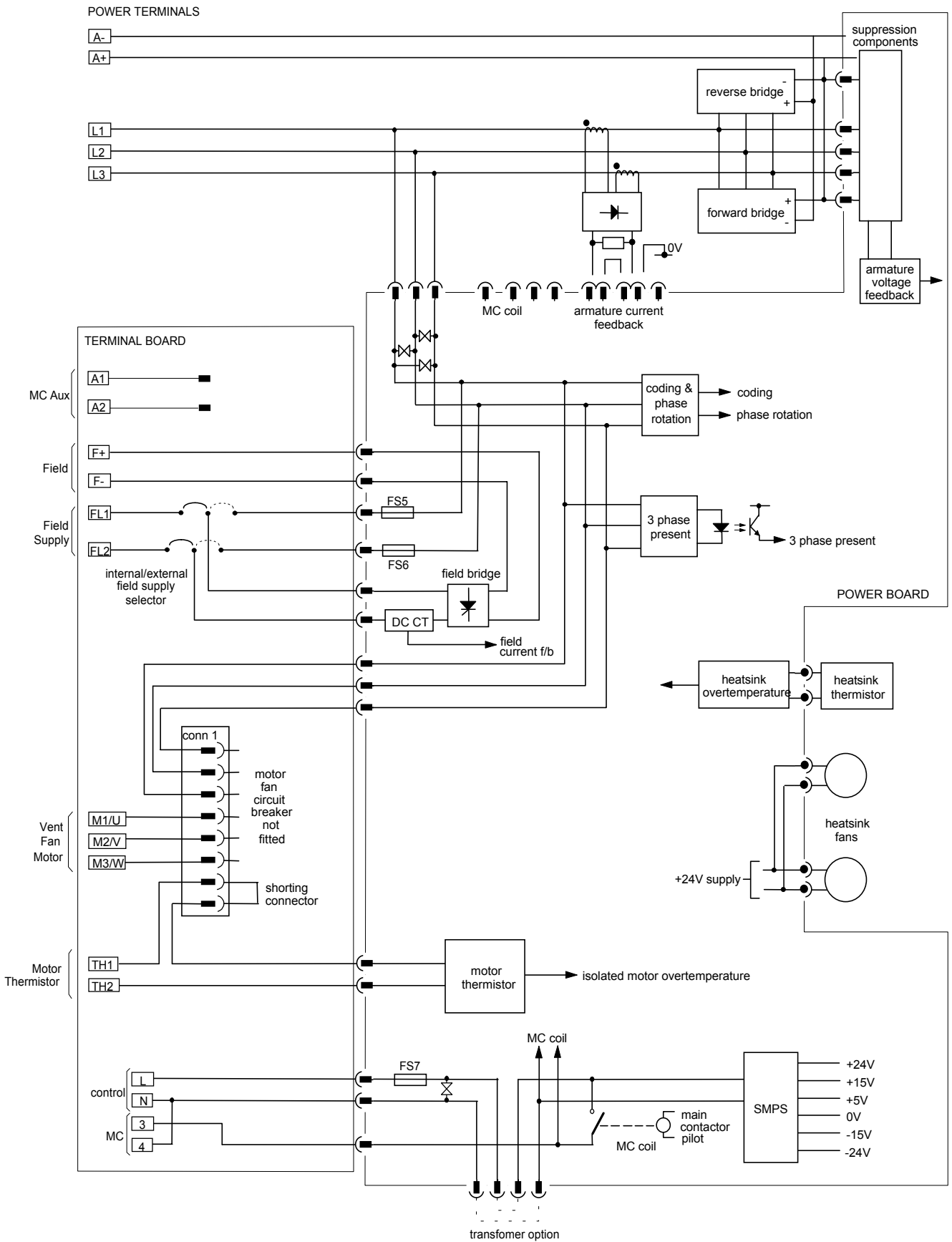

Figure 13-5 AH470330 (Frame 2)

AH385851U002, U003, U004, U005 (Frame 3)

(590+ - 4 Quad, 591+ - 2 Quad; Low and High Volt)

Power supplies for the controller are generated from the single phase auxiliary supply via a switched mode power supply. The incoming supply is directly rectified to provide a high voltage dc power rail. A high voltage transistor switches this rail on to the primary of a high frequency transformer, the output of which is rectified and smoothed to provide the dc power supply rails. The +5V dc rail is monitored via a reference element and a control signal returned via an opto-isolator to the control element of the high voltage switching transistor. The ±15V dc rails are generated via separate secondary windings which are rectified, smoothed and stabilised by linear regulators. The SMPS operates over an input voltage range of 110V to 240V ac ±10%, 50/60Hz. The auxiliary supply fuse FS1 provides protection of the high voltage elements.

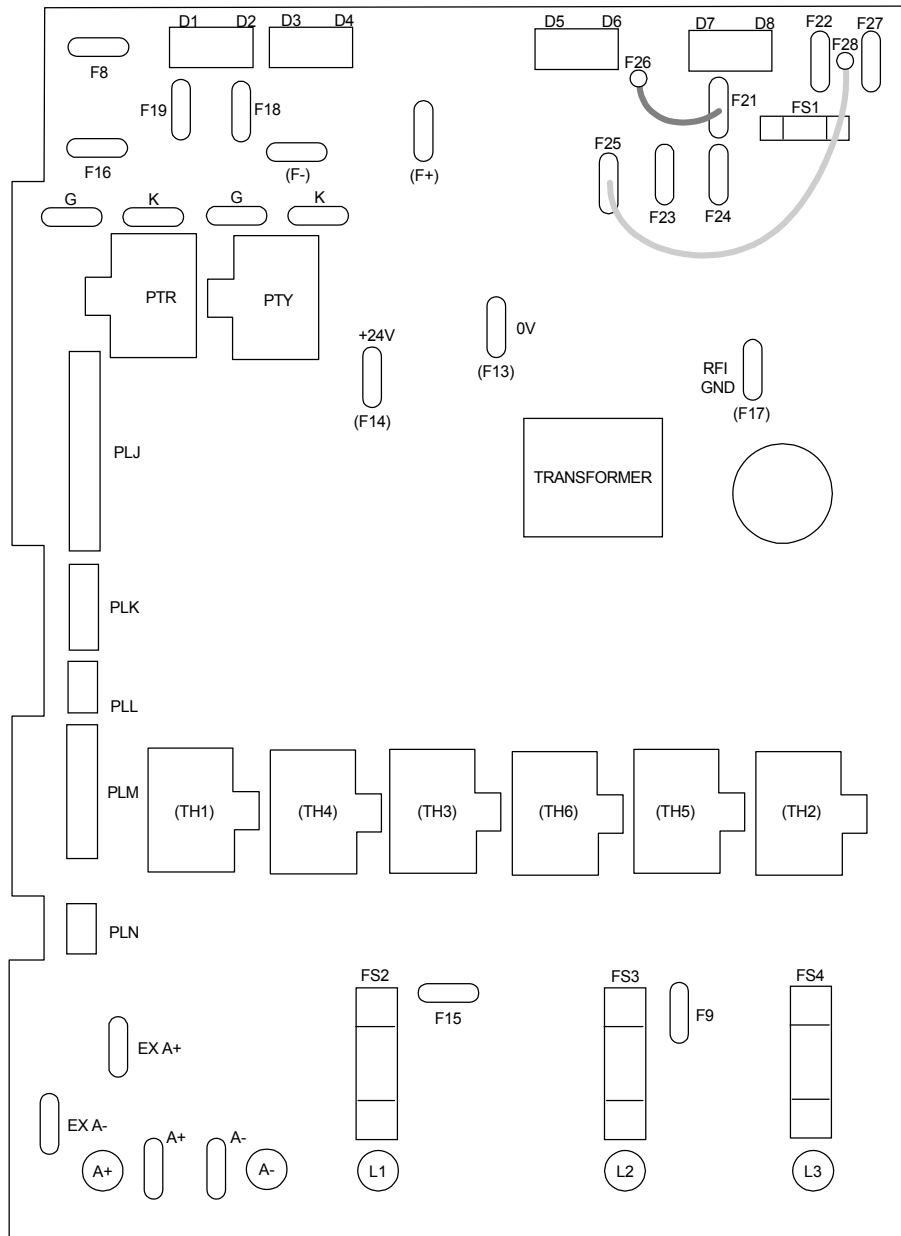

Figure 13-6 591 Power Board 2 Quad (AH385851U003, U004)

13-6 Standard and Optional Equipment

Heatsink Cooling Fan Connections

When fitted, these fans are connected on the power board to FAN LIVE (F27), FAN NEUTRAL (F24) and FAN COMMON (F23) as described below:

- A single fan should be matched to the auxiliary supply and connected to F27 and F24.
- Two fans using a 110/115V auxiliary supply should be connected in parallel to F27 and F24.
- Two fans using a 220/240V auxiliary supply should be connected in series to F27 and F24 using F23 as the centre point.

Contactors Supply

The controller requires an ac or dc power contactor in series with the main power path to ensure correct power-up sequencing. This contactor is directly initiated by the Microcontroller via an isolating relay which drives the contactor coil with the same voltage as that of the auxiliary supply.

This is achieved by the brown wire connection from COIL LIVE (F28) to RELAY (F25) and the blue wire connection from COIL NEUTRAL (F21) to CONTACTOR RETURN (F26).

However, if an alternative supply for the contactor coil is required move the brown wire from F25 to F22, and move the blue wire from F21 to F25. The external coil supply can now be switched using a volt-free contact between terminals D5 and D6.

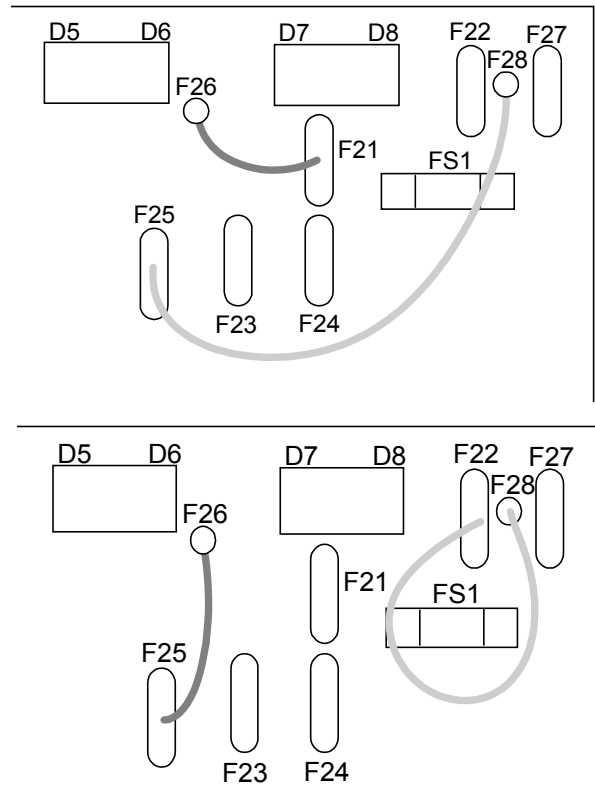

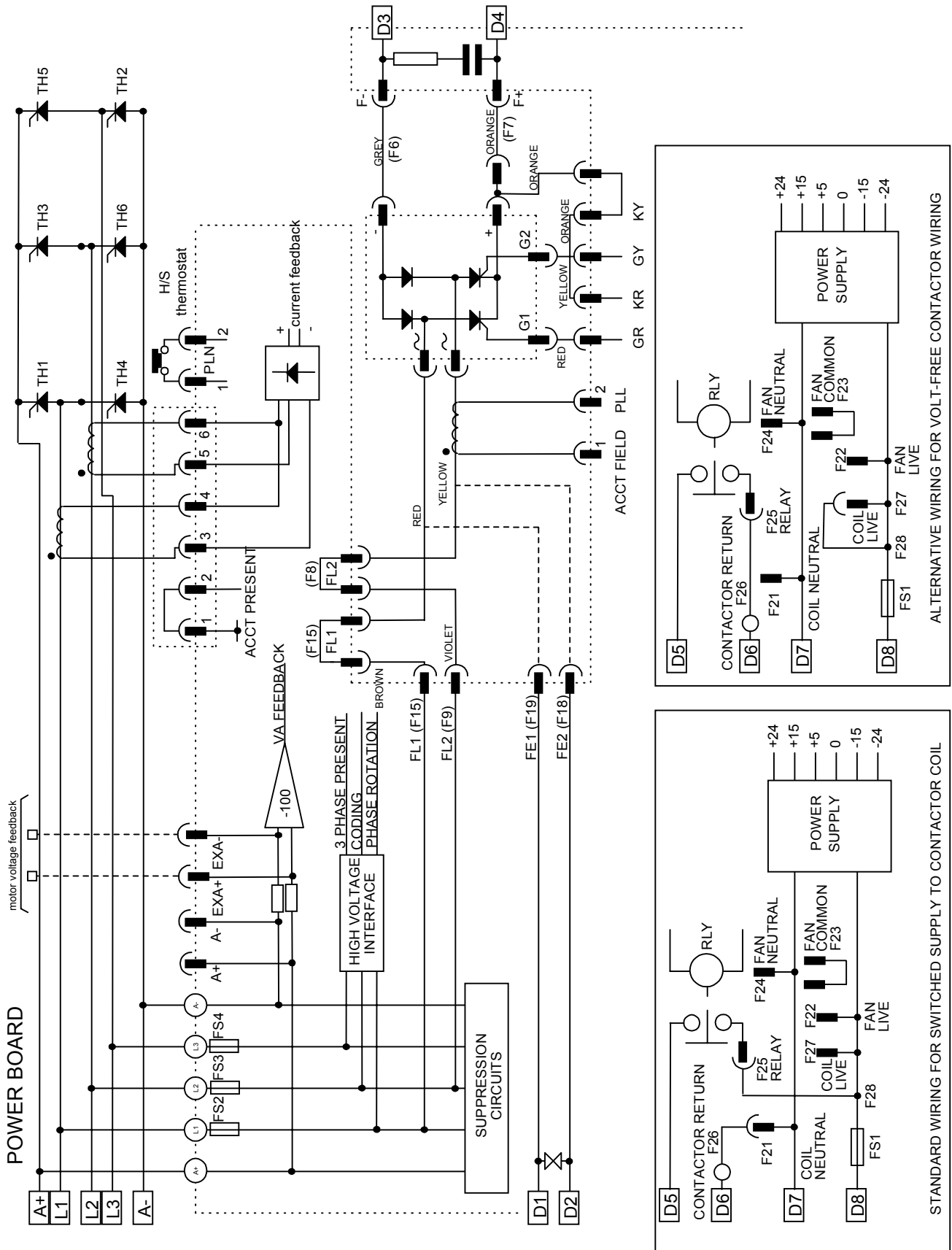

Figure 13-7 2 Quad Power Circuit - using AH385851U003, U004 (Frame 3)

13-8 Standard and Optional Equipment

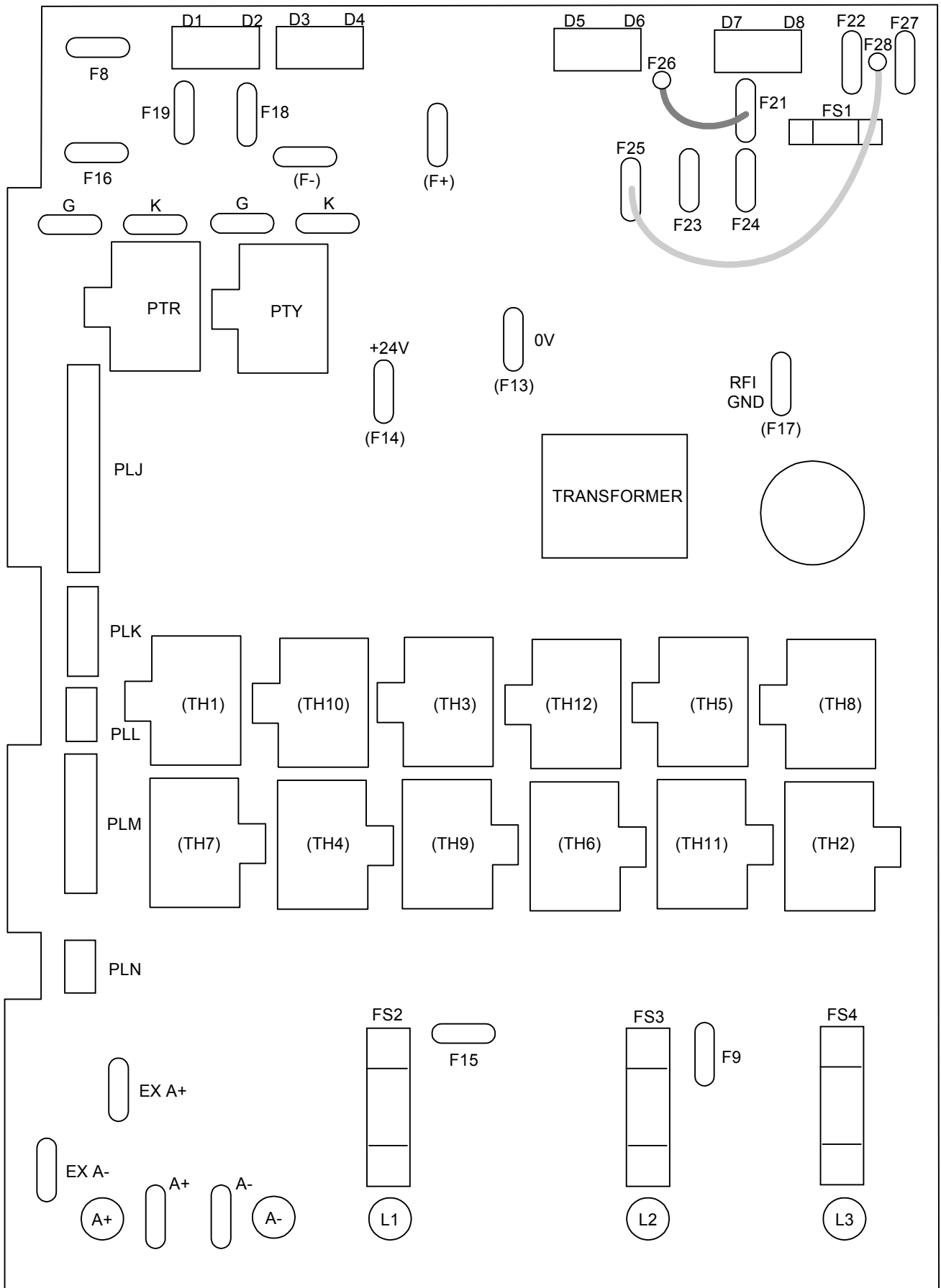

Figure 13-8 590 Power Board 4 Quad (AH385851U002, U005) - (Frame 3)

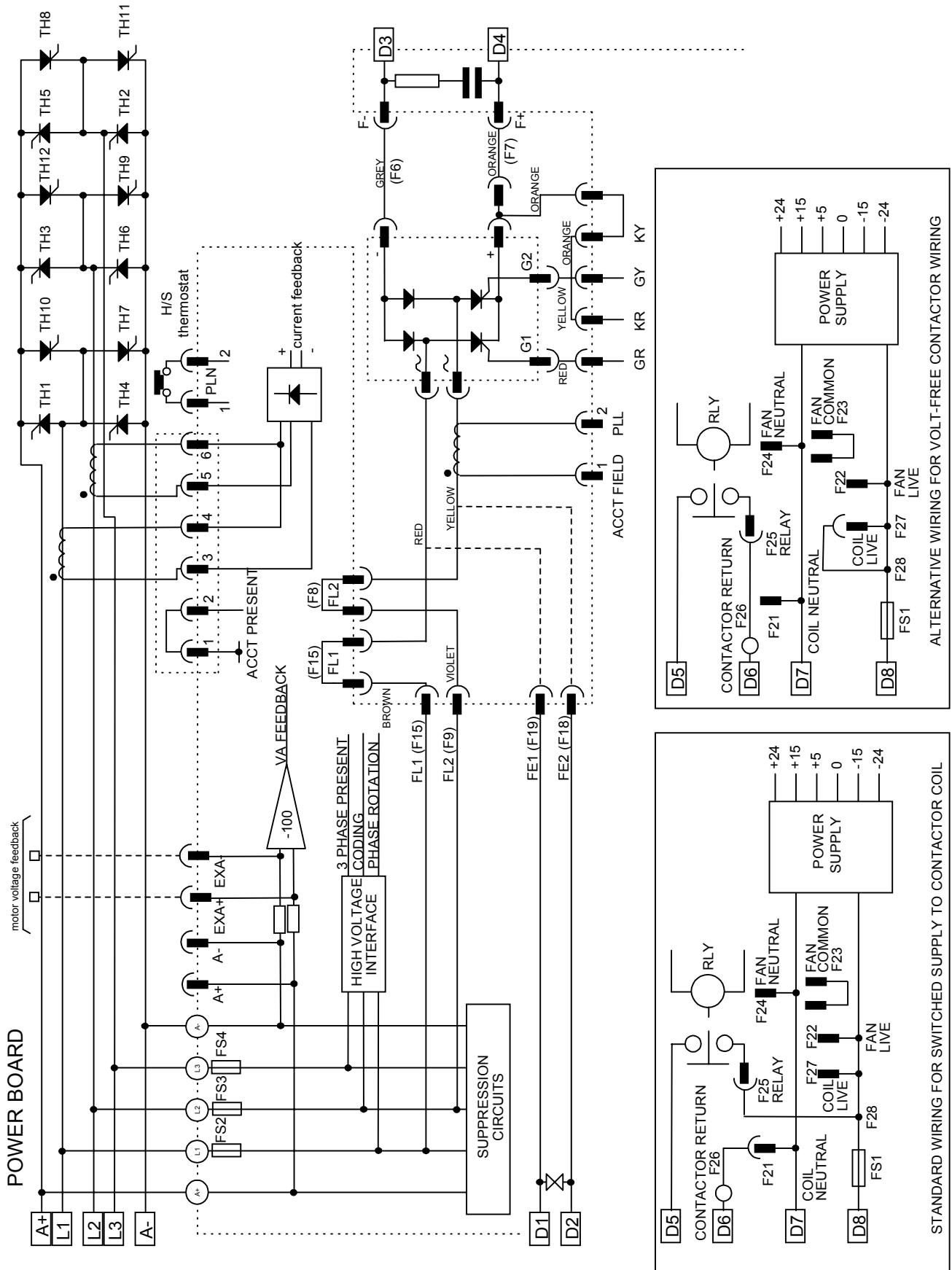

Figure 13-9 4 Quad Power Circuit - using AH385851U002, U005 (Frame 3)

13-10 Standard and Optional Equipment

AH466701U001, U002, U003 (Frames 4 & 5)

590+ 4 Quad and 591+ 2 Quad; Low, Medium and High Volt

Power supplies for the controller are generated from the single phase auxiliary supply via a Switched Mode Power Supply. The incoming supply is directly rectified to provide a high voltage dc power rail. A high voltage transistor switches this rail on to the primary of a high frequency transformer, the output of which is rectified and smoothed to provide the dc power supply rails. The +15V dc rail is monitored via a reference element and a control signal returned via an opto-isolator to the control element of the high voltage switching transistor. The other dc rails (-15V & +24V dc) are generated via separate secondary windings which are rectified and smoothed, with a separate SMPS element providing a regulated +5V dc rail. The SMPS operates over an input voltage range of 110V to 240V ac $\pm 10\%$, 50/60Hz.

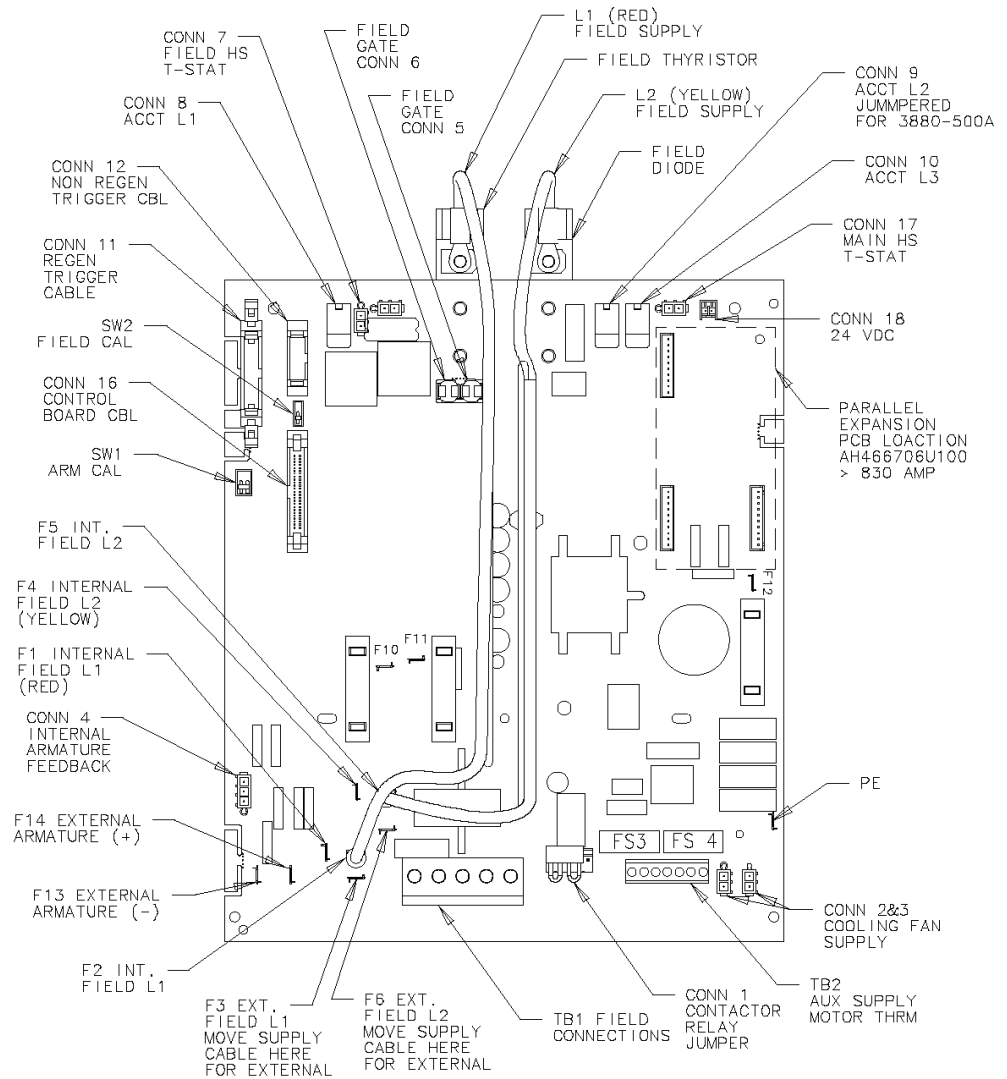

Figure 13-10 590+/591+ Power Board, 4 Quad and 2 Quad (AH466701)

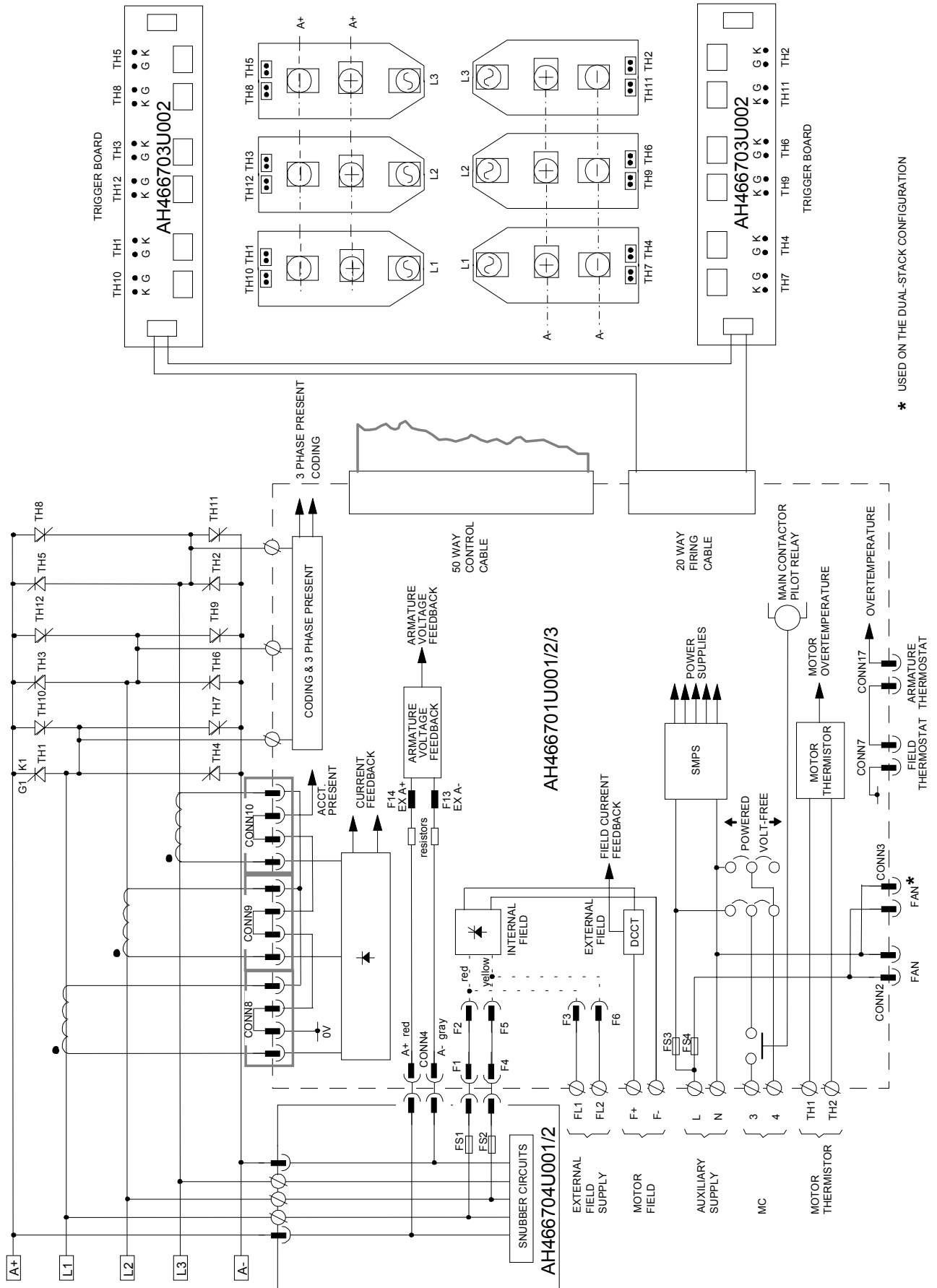
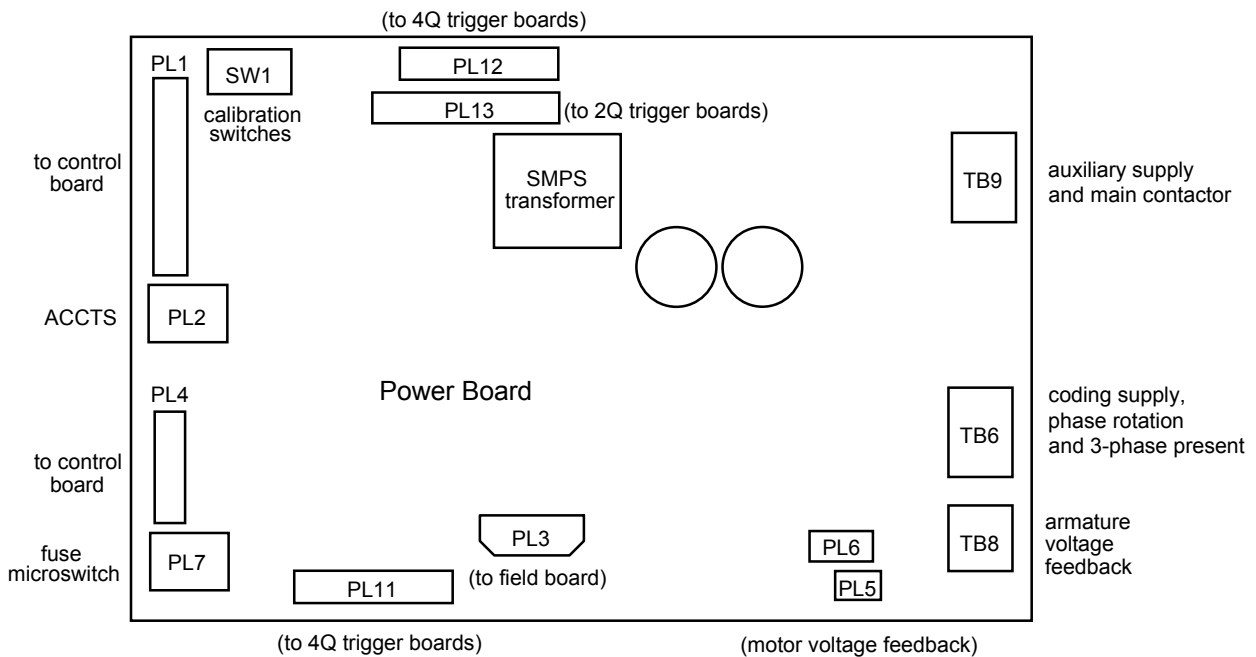
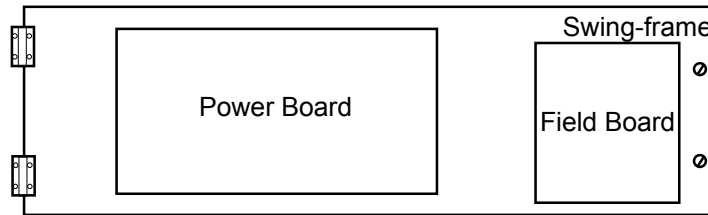

Figure 13-11 4 Quad Power Circuit – Frame 4 & 5 Units using AH466701

AH466001U001, U101 (Frame H)

(590+ - 4 Quad and 591+ - 2 Quad; Low and High Volt)

Power supplies for the controller are generated from the single phase auxiliary supply via a Switched Mode Power Supply. The incoming supply is directly rectified to provide a high voltage dc power rail. A high voltage transistor switches this rail on to the primary of a high frequency transformer, the output of which is rectified and smoothed to provide the dc power supply rails. The 5V dc rail is monitored via a reference element and a control signal returned via an opto-isolator to the control element of the high voltage switching transistor. The other dc rails (-15V & +24V dc) are generated via separate secondary windings which are rectified and smoothed, with individual linear regulators providing $\pm 15V$ dc rail. The SMPS operates over an input voltage range of 110V to 240V ac $\pm 10\%$, 50/60Hz.



13-14 Standard and Optional Equipment

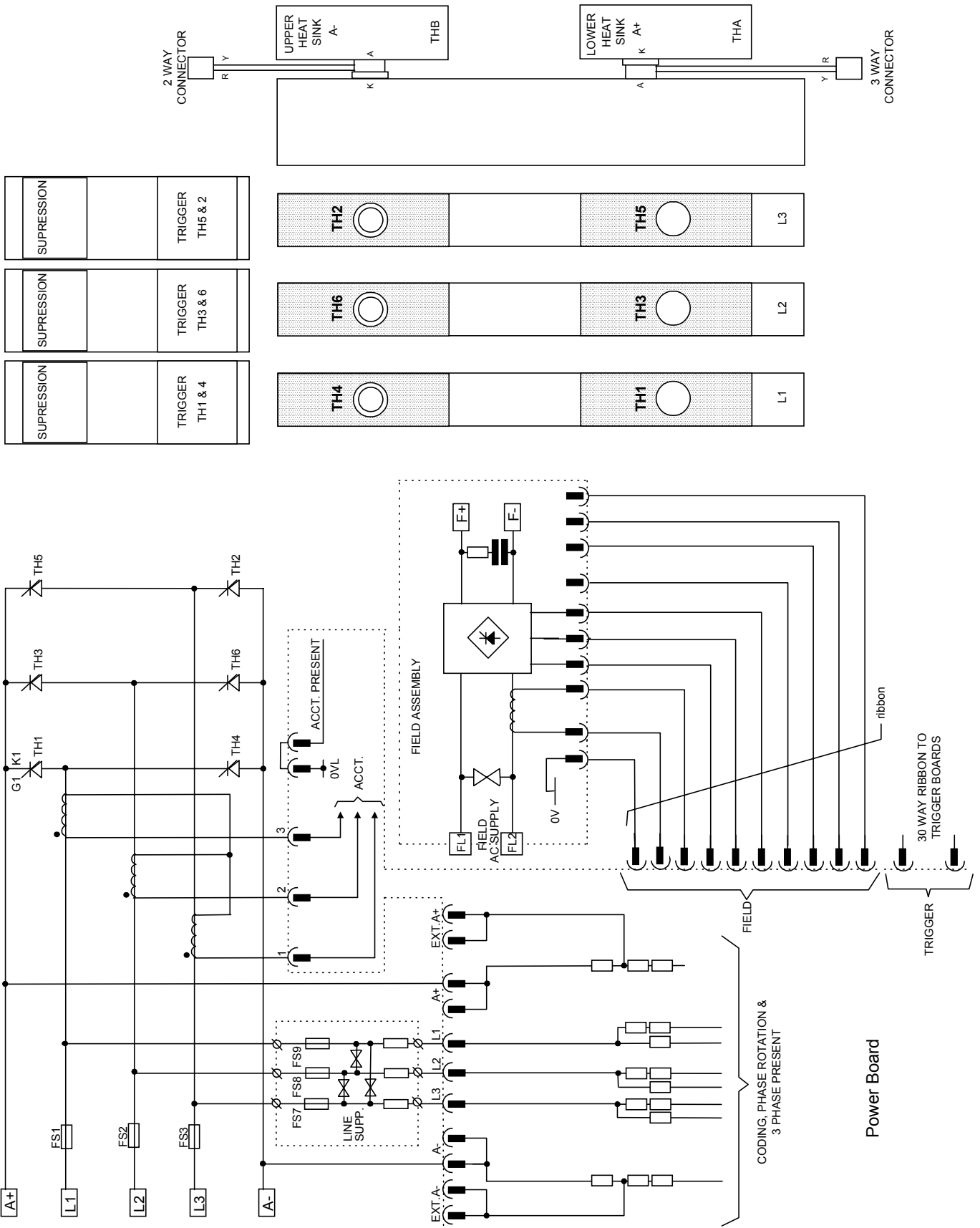

Figure 13-13 2 Quad Power Circuit – Frame H Units using AH466001U001

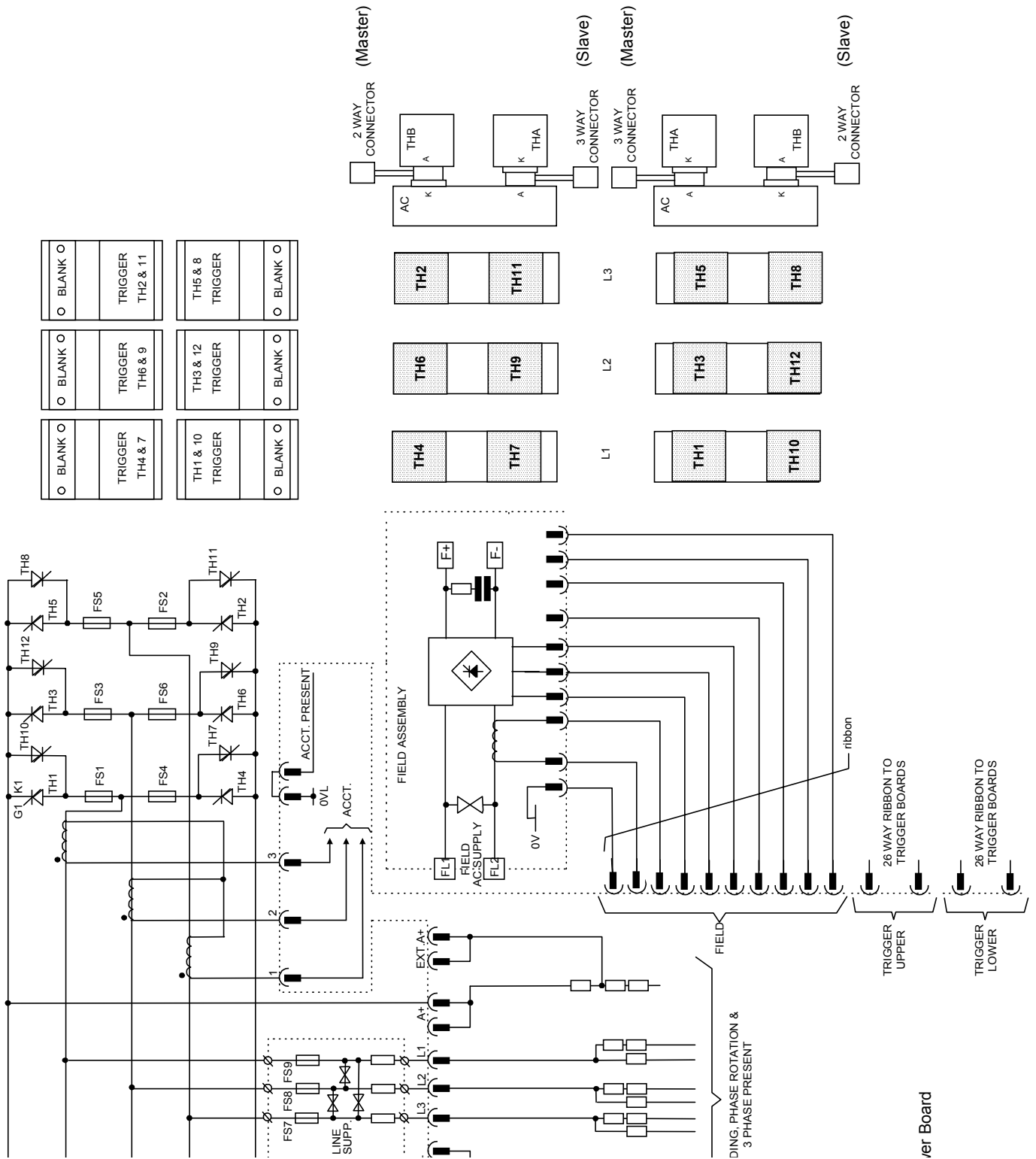

Figure 13-14 4 Quad Power Circuit – Frame H Units using AH466001U001

Optional Equipment

Contact your local Eurotherm Drives office to order optional equipment.

Item	Part Number
EMC Installation Guidelines for Modules and Systems <i>A Eurotherm Drives application manual detailing EMC requirements</i>	HA388879
590 Digital Section Control <i>A Eurotherm Drives application manual detailing the use of the block diagram to implement open and closed loop control of driven web section rolls</i>	HA388664
590 Digital Closed Loop Centre Winder <i>A Eurotherm Drives application manual detailing the use of the block diagram to implement closed loop centre winders</i>	HA388202
ConfigEd Lite <i>Eurotherm Drives' Windows-based block programming software</i>	Order by name
External AC Supply (RFI) Filter <i>For Converters without internal filters, on cable runs in excess of 25 metres</i>	Refer to Chapter 11: "External AC Supply (RFI) Filters" for Part Numbers
Microtach Option Board <i>Two board types for connecting to a plastic or glass fiber Microtach encoder</i> <ul style="list-style-type: none"> • Glass • Plastic 	AH386025U001 AH386025U002
Encoder Option Board <i>A board to interface to a wire-ended encoder</i>	AH377775U001 (universal)
Tacho Calibration Option Board <i>A switchable calibration board for interfacing to AC/DC analog tachogenerators</i>	AH385870U001
Comms Option Board (P1) Board <i>Two board types for supporting EI BYSYNCH or PROFIBUS communication protocols for connection to other equipment.</i> <ul style="list-style-type: none"> • EI BYSYNCH (RS422, RS485) • PROFIBUS • LINK 	6055/EI00/00 6055/PROF/00 6055/LINK/00

Table 13-1 Optional Equipment

Speed Feedback Option Boards

Each option board below is shown with the correct selection for the SPEED FBK SELECT parameter.

The selections are ARM VOLTS FBK, ANALOG TACH, ENCODER and ENCODER/ANALOG.

(ARM VOLTS FBK is default and requires no option board).

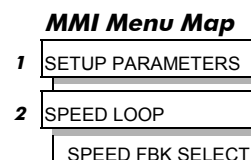

Microtach Option Board

There are two kinds of Eurotherm Drives' Microtach, each requiring a different board:

- 5701 Microtach (plastic fibre)
- 5901 Microtach (glass fibre)

If fitted, refer to the Microtach Technical Manual for further information.

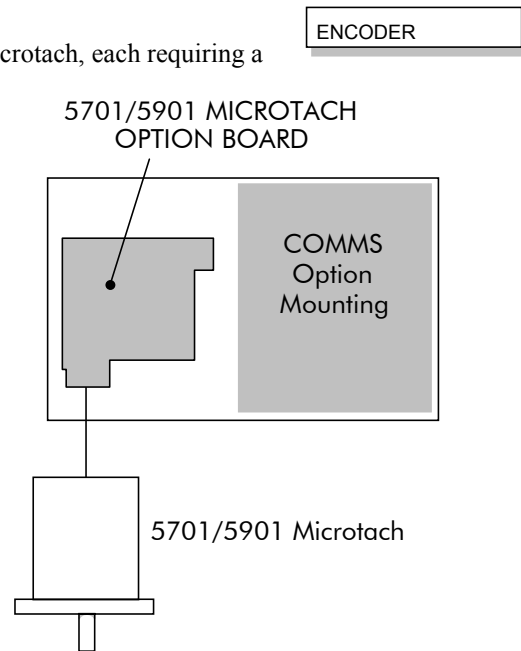

Wire-Ended Encoder Option Board

The board accepts connection from a wire-ended encoder.

If fitted, refer to the Encoder Technical Manual for further information.

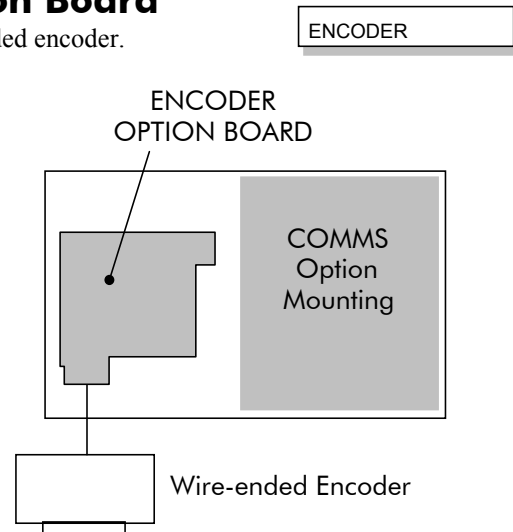

Tacho Calibration Option Board

The board accepts connection from an analog tachogenerator.

If fitted, refer to the Tachogenerator Technical Manual for further information.

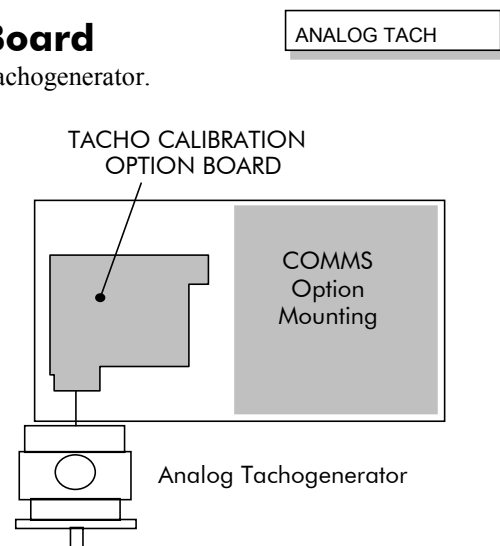

13-18 Standard and Optional Equipment

Combined Tacho and Encoder Feedback

If an analog tachogenerator and digital encoder are to be used, the Encoder Option Board receives the digital signal, the analog signal is routed to Terminals B2 (Tacho) and B1 (0V). Please refer to Eurotherm Drives Engineering Department for assistance with this feature.

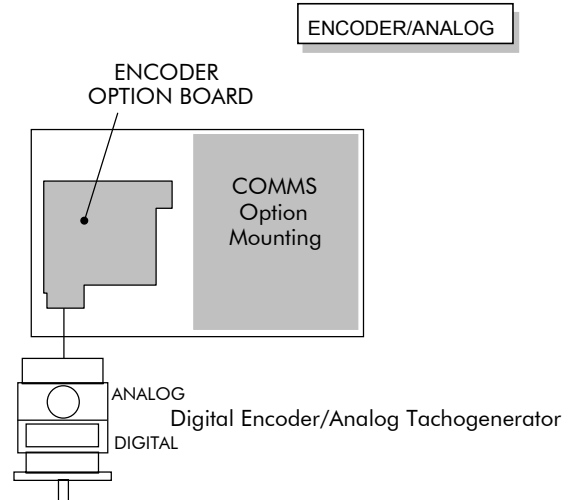

Communications Technology Options

COMMS Option Technology Box

Various protocols are supported, each requiring a different Technology Box. The type of Technology Box fitted is selected in the TYPE parameter:

- RS485 (EI BINARY, EI ASCII or MODBUS RTU)
- PROFIBUS DP
- LINK
- DEVICENET
- CANOPEN
- LONWORKS

The option allows the 590+ Converter to be controlled as part of a system. The system can also comprise other Eurotherm Drives products such as the 605 and 584SV Inverters, or any other equipment using the same protocol.

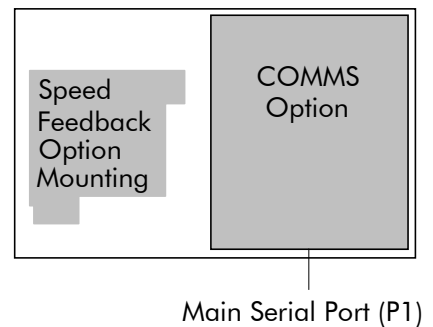
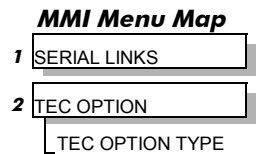

SERIAL COMMUNICATIONS

Communications Technology Option

The plug-in COMMS Option Technology Box provides a serial data port, allowing Converters to be linked together to form a network. Using a PLC/SCADA or other intelligent device, this network can be continuously controlled to provide supervision and monitoring for each Converter in the system. Refer to the Communications Interface Technical Manual for further details.

Config Ed Lite

This is Eurotherm Drive's Windows-based block programming software. It has a graphical user-interface and drawing tools to allow you to create block programming diagrams quickly and easily. Contact your local Eurotherm Drives sales office.

System Port (P3)

This port has several uses:

1. **ConfigEd Lite:** Parameters can be monitored and updated by ConfigEd Lite (or other suitable PC programming tool)
2. **UDP Support:** It can be used to upload and download information to a PC
3. **5703 Support:** A Eurotherm 5703 Setpoint Repeater Unit can be connected

The port is an un-isolated RS232, 9600 Baud (default), supporting the standard EI BISYNCH ASCII communications protocol, contact Eurotherm Drives for further information.

A standard P3 lead is used to connect to the Converter.

P3 Port Pin	Lead	Signal
1	Black	0V
2	Red	24V
3	Green	TX
4	Yellow	RX

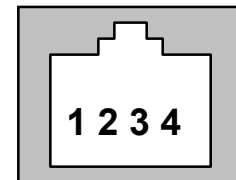

6-Way Lead to DB9/DB25 Connector

Note: There is 24V present on pin 2 of the P3 port. This may damage your PC or the Converter.

P3 Port Pin	Lead	Female DB9 Pin	Female DB25 Pin
1	Black	5	7
2	Red	not connected	not connected
3	Green	2	3
4	Yellow	3	2

UDP Support

The P3 port can be used to transfer an ASCII representation of the converter's settings between the Converter and a host computer.

The transfer uses a simple ASCII file structure and XON / XOFF protocol. This is provided by most communications packages. Host computers tested include IBM PCs XT/AT, running both Windows and MSDOS, Psion Organiser 3 and many more.

Transferring data from the Converter to a host computer is defined as "Downloading", whereas transferring data from a host computer to the Converter is defined as "Uploading".

Refer to Chapter 6: "Programming Your Application" - SYSTEM PORT P3 for parameter details.

UDP Menu Structure

```

.....SYSTEM PORT (P3)
.....P3 SETUP
.....MODE //          Disable/5703 Setup Mode
.....5703 SUPPORT //   Submenu for 5703 parameters
.....P3 BAUD RATE //   Baud rate for the P3 Port
.....DUMP MMI (TX) //  Transfer the MMI to Host
.....UDP XFER (RX) //  Transfer Parameters From Host
.....UDP XFER (TX) //  Transfer Parameters To Host
    
```

SYSTEM PORT (P3) Setup

Set MODE parameter (Tag No. 130) to DISABLE (default) using the MMI

Set P3 BAUD RATE parameter (Tag No. 198) to 9600 (default) using the MMI

1 Stop bit (fixed)

NO Parity (fixed)

8 bits (fixed)

XON/XOFF Handshaking (fixed)

MMI Menu Map

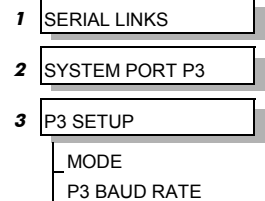

UDP Transfer Procedure

UDP UpLoad (UDP XFER (RX))

This is the transfer of the parameters from the host computer to the Converter. This information is written directly to EEprom, so **all the drive's current settings will be overwritten.**

- Connect the Converter to the host using the appropriate lead.
- Using a standard communications package prepare the host to transfer an ASCII file. Remember to set up the host's serial port first.
- Set the P3 MODE parameter to DISABLE.
- Start uploading on the Converter by selecting UDP XFER (RX) on the MMI and pressing the UP (↑) key, as instructed.
- When the Converter says RECEIVING, begin the file transmission.
- The file ends in a **:00000001FF** which the Converter uses to close the file.
- As indicated, reset the Converter by pressing the E key.

MMI Menu Map

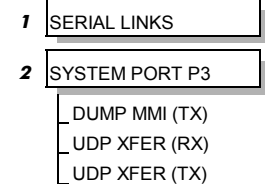

UDP Download (UDP XFER (TX))

This is the transfer of the parameters from the Converter to a host computer. This information fully describes the Converter's settings in a Binary format.

- Connect the Converter to the host using the appropriate lead.
- Using a standard communications package prepare the host to receive an ASCII file. Remember to set up the host's serial port first.
- Perform a PARAMETER SAVE of the Converter's settings. This ensures the Dump matches the Converter's settings, (the listing is of the Converter's currently saved settings, i.e. held in EEprom).
- Set the P3 MODE parameter to DISABLE.
- Prepare the host PC to receive a file; use the file extension .UDP to differentiate it from .MMI format files.
- Start downloading on the Converter by selecting UDP XFER ((TX) on the MMI and pressing the UP (↑) key, as instructed.

- The file ends in a ctrl-z. With some packages this automatically closes the downloaded file but if this is not the case, when the Converter says it has finished and the host has stopped scrolling text, close the file by hand. The last line should read : **0000001FF**

The file can now be treated like any normal file.

Download MMI (MMI DUMP (TX))

This is the transfer of the MMI description from the Converter to a host computer. This information fully documents the Converter's settings in a textual format that is clear and easy to read.

- Connect the Converter to the host using the appropriate lead.
- Using a standard communications package prepare the host to receive an ASCII file. Remember to set up the host's serial port first.
- Perform a PARAMETER SAVE of the Converter's settings. This ensures the Dump matches the Converter's settings, (the listing is of the current settings, NOT the saved settings held in EEprom).
- Set the P3 MODE parameter to DISABLE.
- Prepare the host PC to receive a file; use the file extension .MMI to differentiate it from .UDP format files.
- Start downloading on the Converter by selecting DUMP MMI (TX) on the MMI and pressing the UP (↑) key, as instructed.
- The file ends in a ctrl-z. With some packages this automatically closes the file but if this is not the case, when the Converter says it has finished and the host has stopped scrolling text, close the file by hand.
- The file can now be treated like any normal text file.

MMI Dump

The following file was produced by performing a MMI DUMP (TX) to a PC, as described above. The file shows the Converter default settings.

Note: When printing this file, it is useful to select a proportionally-spaced text, such as Courier, so that the text columns line-up. Note that in the list below, 'menus' have been highlighted (bold) to make the list easier to use.

```
DIGITAL DC DRIVE
ISSUE:4.4
..MENU LEVEL
...DIAGNOSTICS
.....SPEED DEMAND      [89 ] = 0.00 %
.....SPEED FEEDBACK    [207 ] = 0.00 %
.....SPEED ERROR       [297 ] = 0.00 %
.....CURRENT DEMAND    [299 ] = 0.00 %
.....CURRENT FEEDBACK [298 ] = 0.00 %
.....POS. I CLAMP      [87 ] = 0.0 %
.....NEG. I CLAMP      [88 ] = 0.0 %
.....ACTUAL POS I LIM  [67 ] = 0.0 %
.....ACTUAL NEG I LIM  [61 ] = 0.0 %
.....INVERSE TIME O/P [203 ] = 200.00 %
.....AT CURRENT LIMIT [42 ] = FALSE
.....AT ZERO SPEED     [77 ] = TRUE
.....AT ZERO SETPOINT [78 ] = TRUE
.....AT STANDSTILL     [79 ] = TRUE
.....STALL TRIP        [112 ] = OK
.....RAMPING           [113 ] = FALSE
.....PROGRAM STOP      [80 ] = TRUE
.....DRIVE START        [82 ] = OFF
.....DRIVE ENABLE      [84 ] = DISABLED
.....OPERATING MODE    [212 ] = STOP
.....FIELD ENABLE      [169 ] = DISABLED
.....FIELD DEMAND      [183 ] = 0.00 %
```

Example only

14-4 Serial Communications

5703 Support

This unit provides the facility to run a line of converters in speed-lock without the use of a 5720 Quadraloc controller; for accurate speed-holding, encoder feedback is required. Ratioed speed-locking is supported, although the unit is not intended to replace the Quadraloc in applications requiring high accuracy.

A 16-bit speed signal is passed between drives through a fibre-optic link and the P3 port on each Converter (a port otherwise used only off-line for the upload and download of EEPROM data). The port operates RS232 compatible signal levels, the 5703/1 converts these signal levels to fibre optic signals for transmission and from fibre optics to RS232 for reception.

Hardware Description

The 5703/1 is housed in a DIN rail mounted box and is provided with a cable to connect into the P3 port. The cable is 400mm long to limit transmission errors, the primary unit -to-unit interconnection is intended to be achieved by a fibre optic cable.

The 5703 unit itself is simply an electric signal-to-light converter and does not alter the signal in any way, this is achieved within the software data of the Converter.

It is fitted with one fibre optic receiver and two fibre optic transmitters, the fibre optic receiver has a fixed function to receive data from the preceding unit while the transmitter sends data to the following unit. The additional transmitter can be used either to re-transmit the incoming signal or provide a second transmission of the output signal, this gives the unit wide functionality. When the link is in the normal right hand position, assuming the board is mounted with the fibre optics downward, the second transmitter repeats the output signal. In the left hand position it repeats the input signal.

The 5703/1 can be configured to point to any relevant parameter in the block diagram, the default connections are such that the scaled input is connected to the "additional speed demand" and the output to the "speed demand".

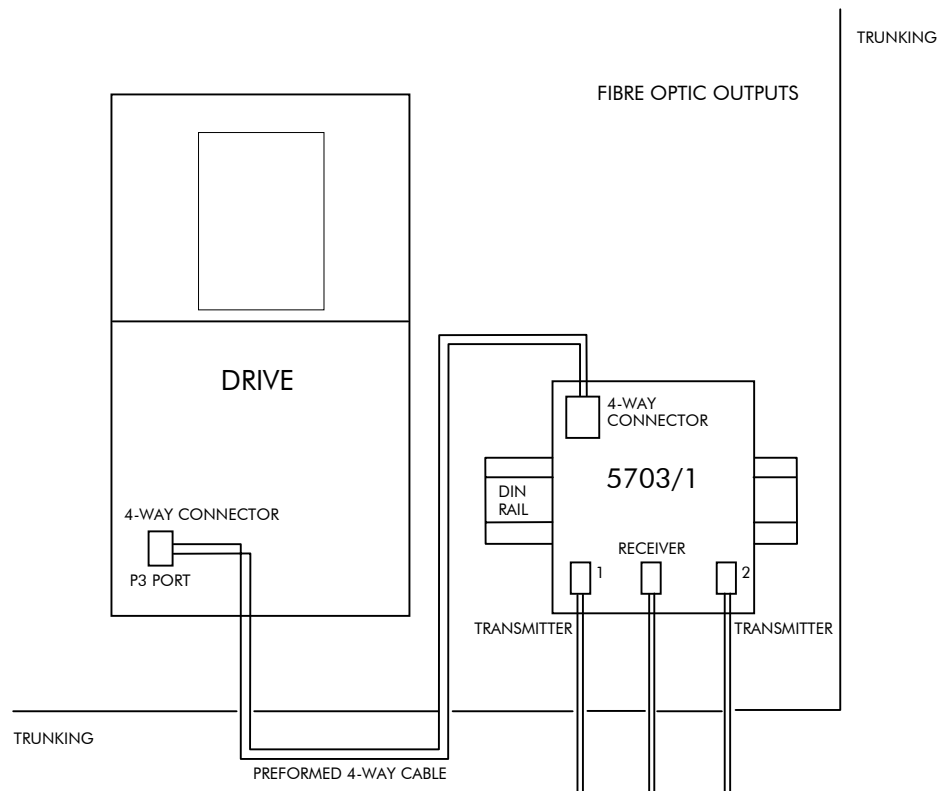

Figure 14-1 5703/1 Product Outline Drawing

Commissioning the 5703/1

The P3 port is configured for 5703 support using the MMI. The Converter's RS422 serial link will then allow control over the scaling of the input by an operator station or by a host processor. Refer to Chapter 15: "The Default Application" for the block diagram, and also see Figure 14-2 Wiring Diagram for 5703/1 Speed Repeater below.

Refer to Chapter 6: "Programming Your Application" - 5703 SUPPORT for parameter details.

MMI Menu Map

1	SERIAL LINKS
2	SYSTEM PORT P3
3	P3 SETUP
4	5703 SUPPORT
	SETPT. RATIO
	SETPT. SIGN
	5703 INPUT
	5703 OUTPUT

The Inputs of the Drive

The speed setpoint from the 5703/1 enters the drive via the P3 port and, after scaling, is added together with analog inputs 1, 2 and 3 (ramped).

IN BASIC TACHO-FOLLOWER MODE, ALL THE ANALOG INPUTS MUST BE DISABLED TO PREVENT LOSS OF ACCURACY, yet it may be necessary in some applications to provide analog inputs for trim signals or inch setpoints:

1. The ramp input may be disabled by taking terminal C7 (Ramp Hold) permanently high; the ramp is automatically cleared when the drive is quenched, and its output will never move from (exactly) zero. The ramp input may often be of use in line master drives; but the ramp should be disabled in slave drives. Note that the P3 setpoint may be passed through the ramp function; in such a case, the analog input to the ramp (terminal A4) is automatically disconnected.
2. Analog input 1 (terminal A2) is used for inch setpoints. During normal running, the terminal is shorted to 0V and the deadband function is used so that no signal at all passes to the summing junction. The analog inch setpoints are set a little above the threshold of the deadband so as to give the required inching speeds, forward or backward. Selection between analog inching and absolutely zero analog input is thus accomplished automatically.
3. Analog input 2 (terminal A3) may be disabled by writing zero to its scaling block; this will normally be done through the MMI at commissioning, but may be overridden by the serial link. Alternatively, this input may be used for a local analog trim.

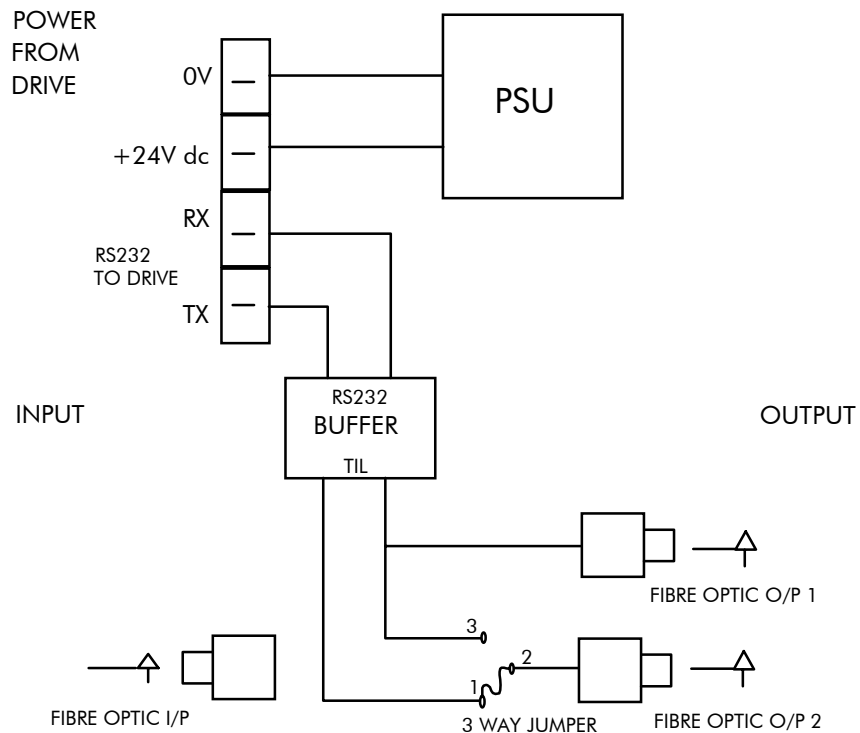

Figure 14-2 Wiring Diagram for 5703/1 Speed Repeater

Error Codes

ERROR REPORT (EE)

The EI-BISYNCH Prime Set contains the EE mnemonic. This is also an output parameter in the MAIN PORT (P1), AUX PORT (P2) and SYSTEM PORT (P3) function blocks, where the parameter value can be read and reset. Refer to the COMMS Option Technical Manual for further details.

The following values are returned if an enquiry (reading information from the Converter) is performed on this Read/Write parameter.

Writing any value to this parameter will set the value to >00C0. Clearing the last error value may be useful in seeing a repetitive error re-occurring.

Value	Description
>00C0	No error
>01C7	Invalid mnemonic
>02C2	Checksum (BCC) error
>03C2	Framing or overrun error
>04C8	Attempt to read from a write-only parameter
>05C8	Attempt to write to a read-only parameter
>07C7	Invalid message format
>07C8	Invalid data (encoding error)
>08C8	Data out of range

THE DEFAULT APPLICATION

Block Diagrams

The Converter is supplied with a pre-programmed set of parameters providing for basic speed control. The following block diagrams show this factory set-up.

If you make any permanent changes to the block diagram, remember to update the non-volatile memory within the Converter by performing a PARAMETER SAVE. Refer to Chapter 5: “The Operator Station” - Saving Your Application.

To return to the default application, refer to Chapter 5: “The Operator Station” - Menu Shortcuts and Special Key Combinations.

15-2 The Default Application

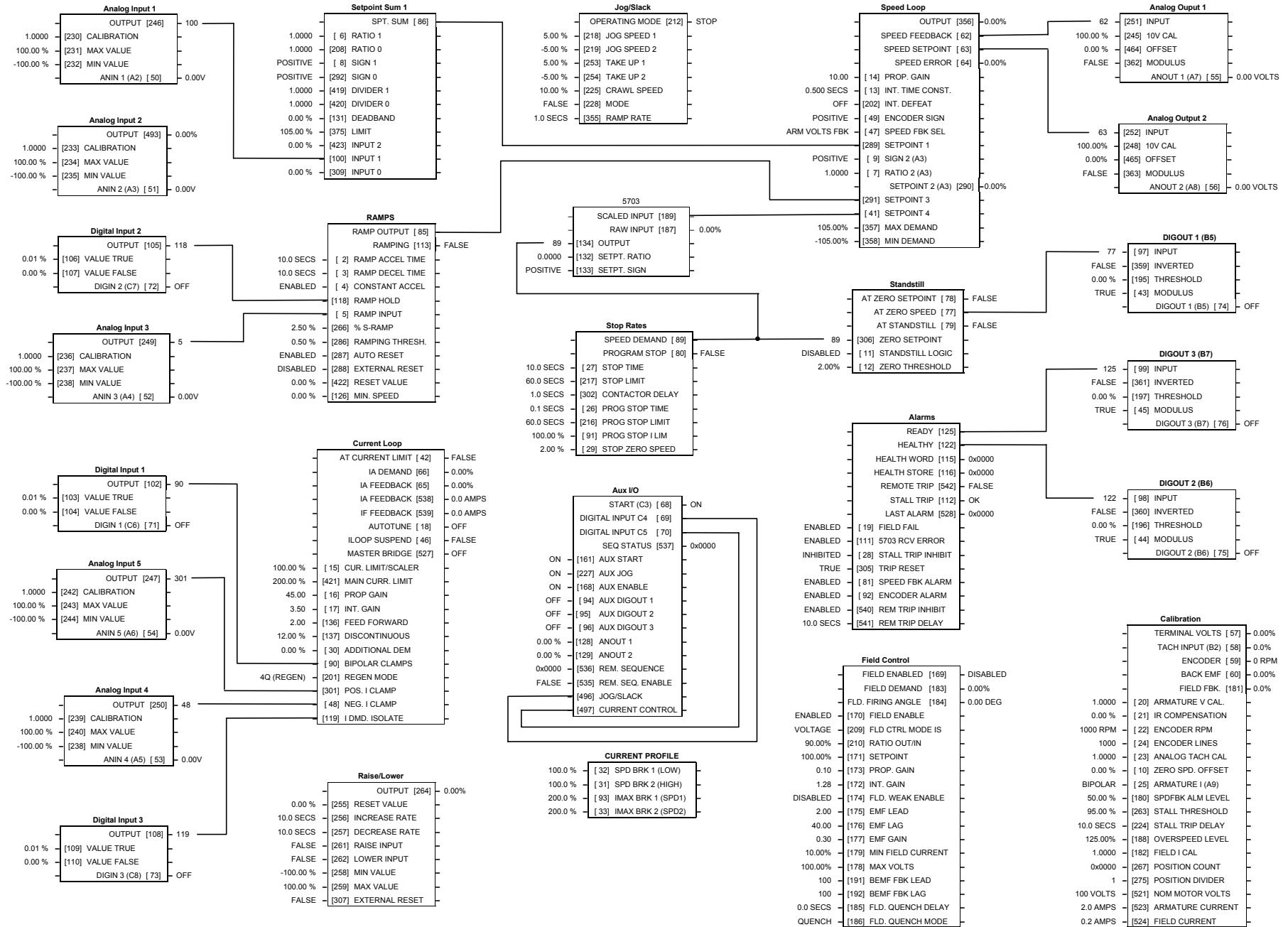

Programming Block Diagram - Sheet 1

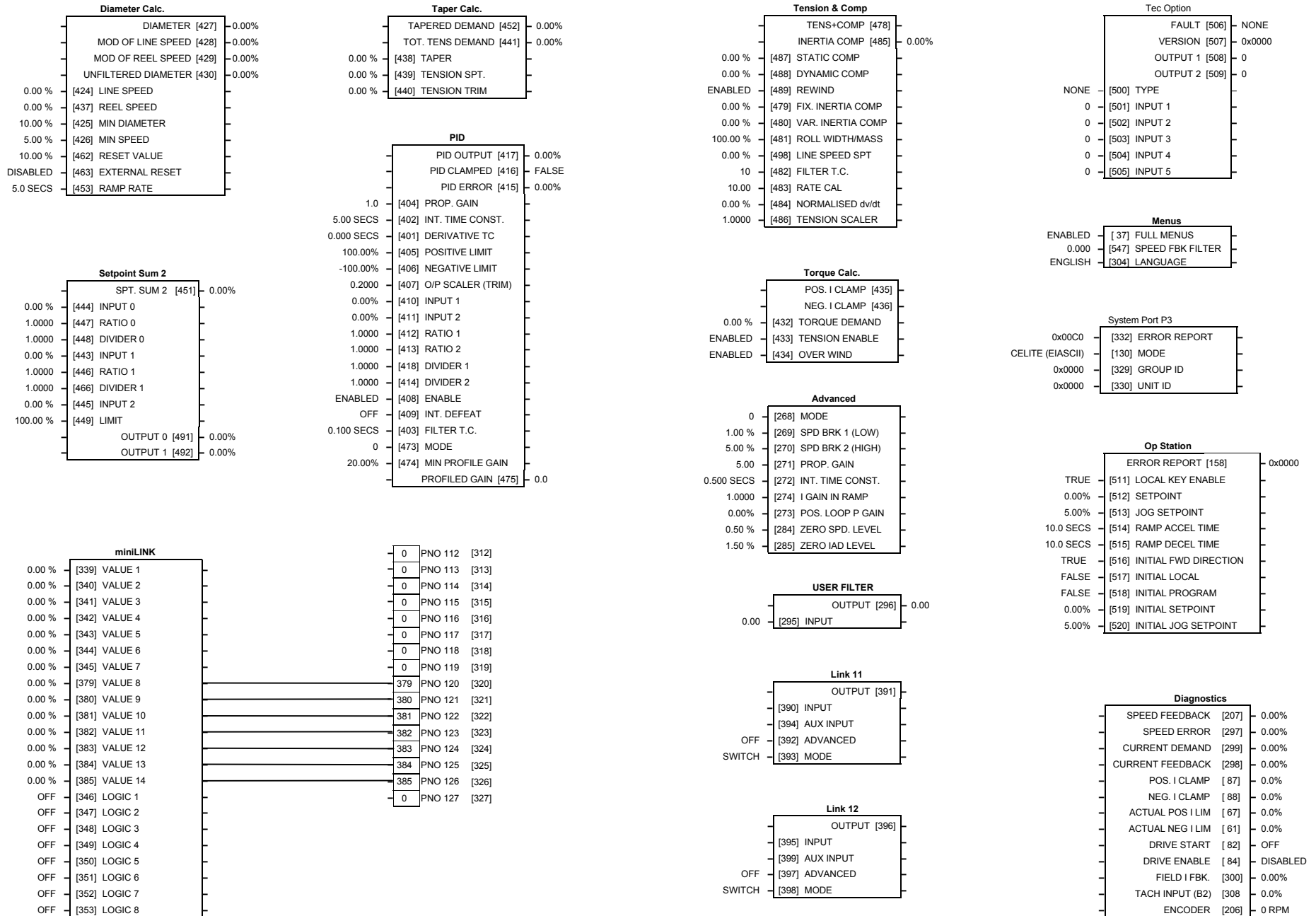

Programming Block Diagram - Sheet 2

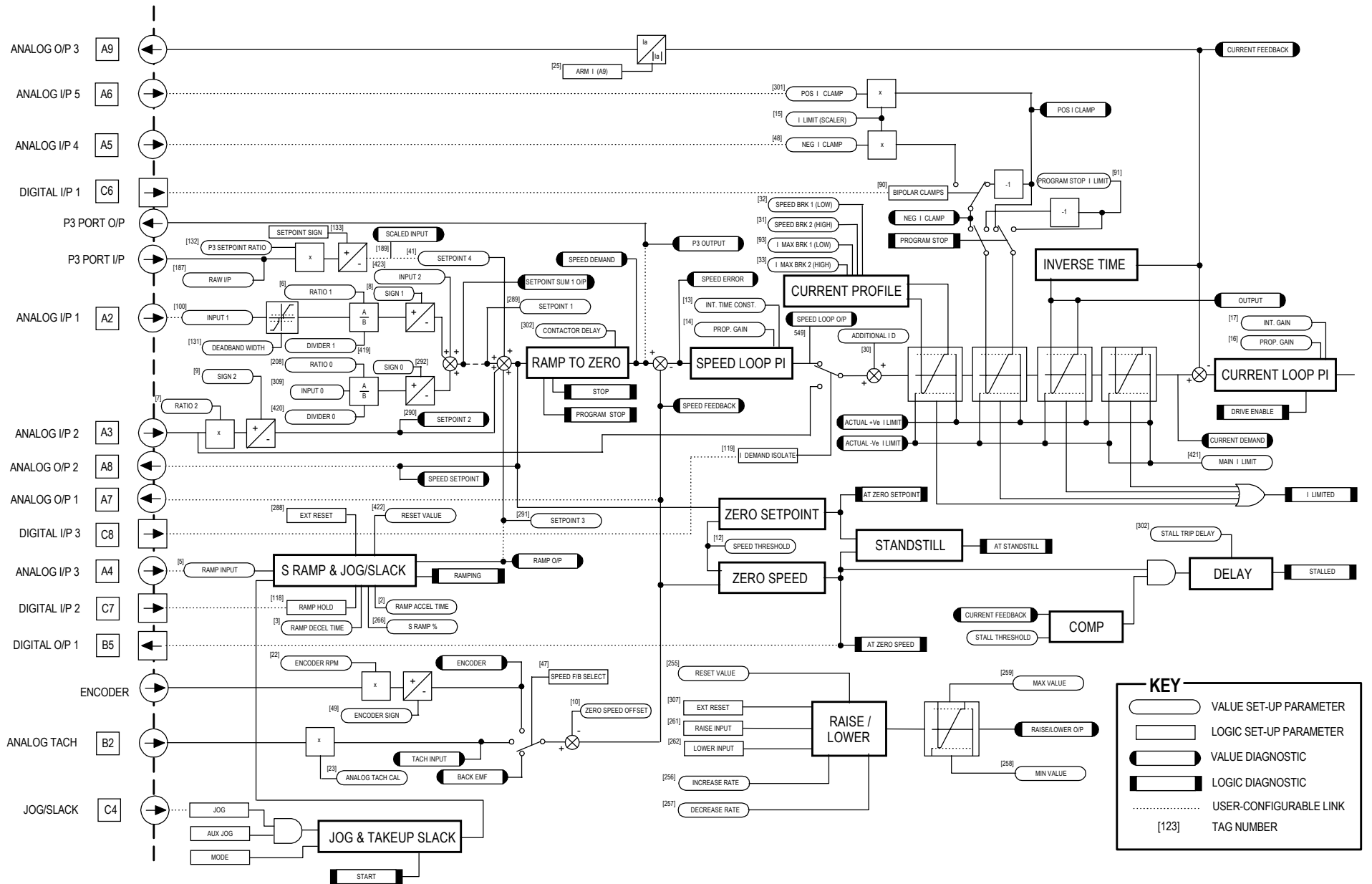

Main Block Diagram

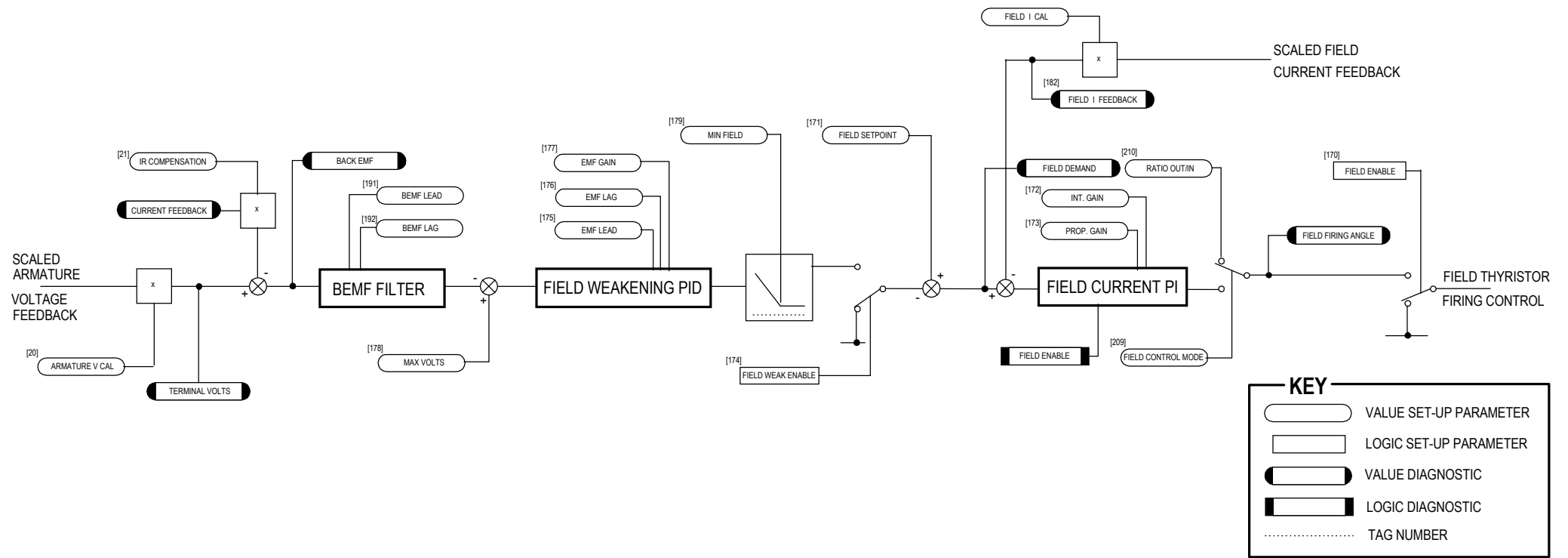

KEY

- VALUE SET-UP PARAMETER
- LOGIC SET-UP PARAMETER
- VALUE DIAGNOSTIC
- LOGIC DIAGNOSTIC
- TAG NUMBER

Field Control Block Diagram

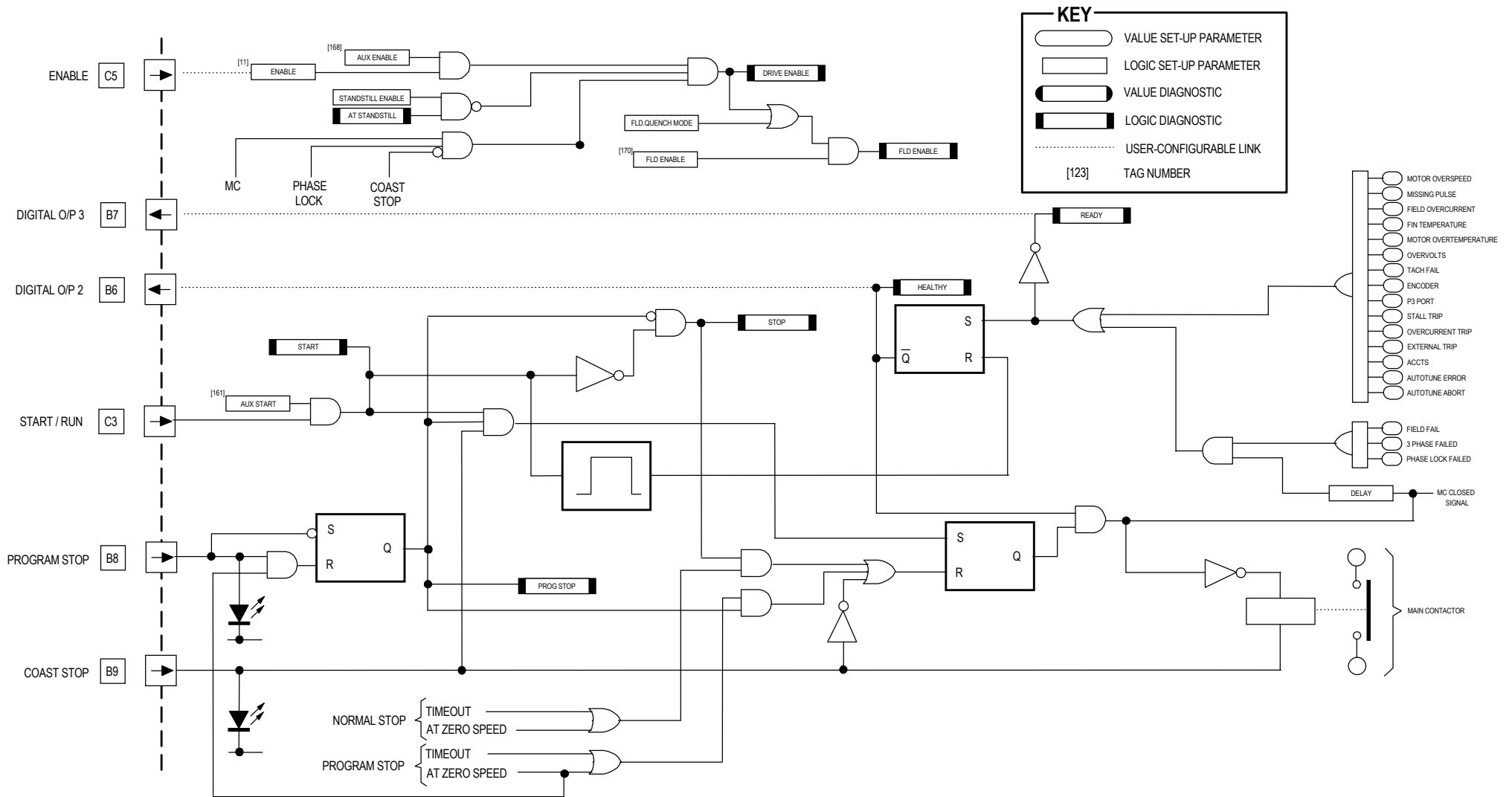

Start/Healthy Logic Block Diagram

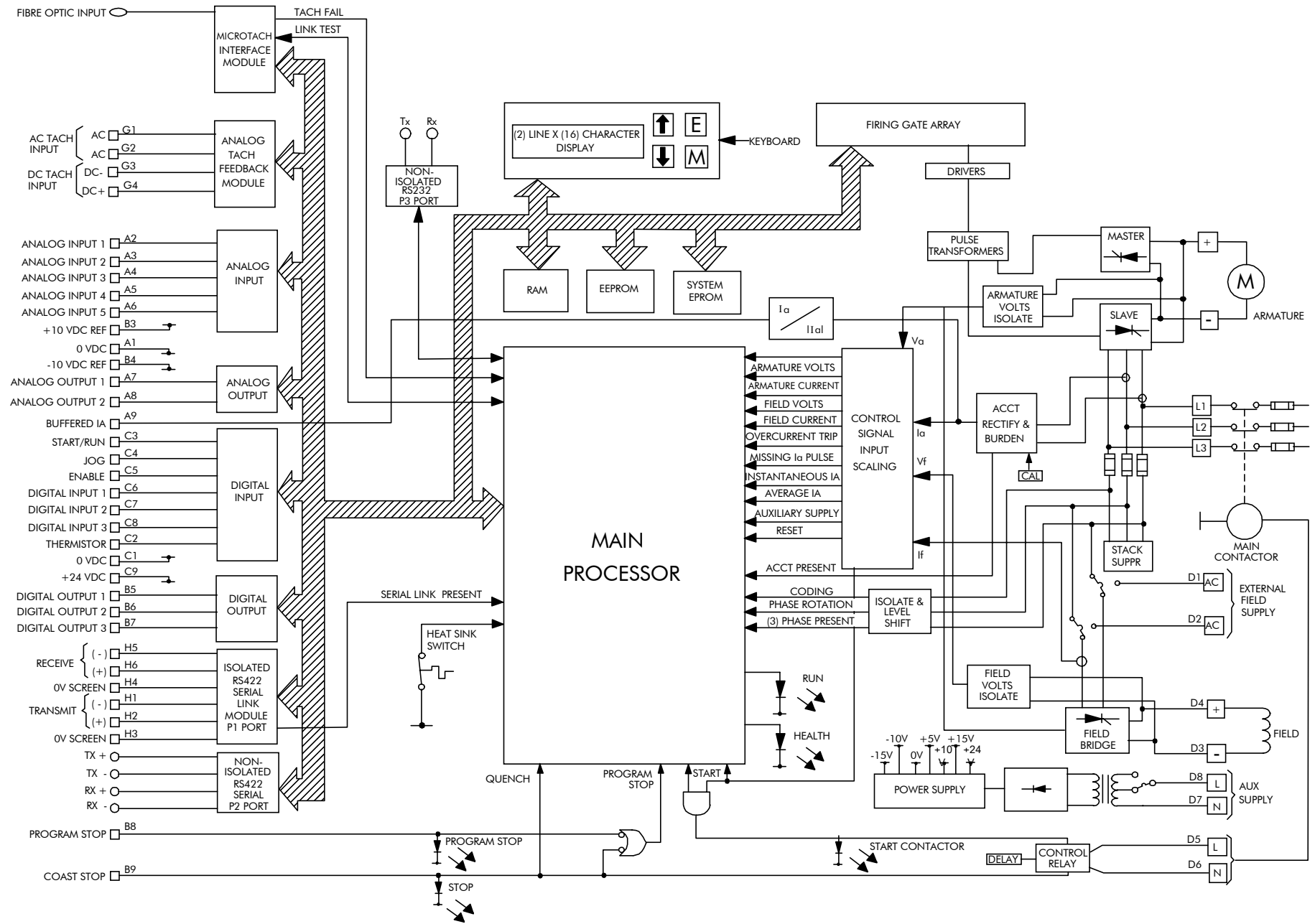

Functional Block Diagram

ISS.	MODIFICATION	ECN No.	DATE	DRAWN	CHK'D
1	HA466461U002 - Contains Frame 4 and software version 5.x. Replaces manual HA466461U001.	16158	7/8/01	CM	GR
FIRST USED ON		MODIFICATION RECORD 590+ Series DC Digital Converter			
 EUROTHERM DRIVES		DRAWING NUMBER ZZ466461U002			SHT. 1 OF 1

