

NK, NKE, NKG, NKGE

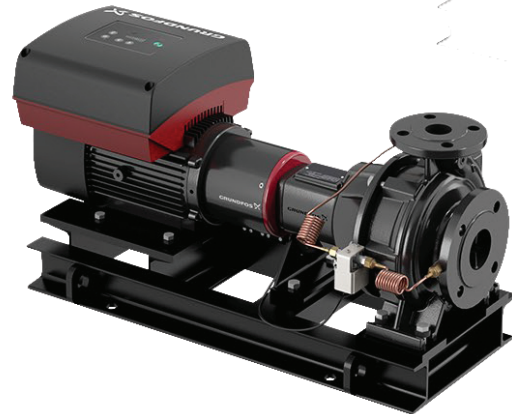

Service instructions

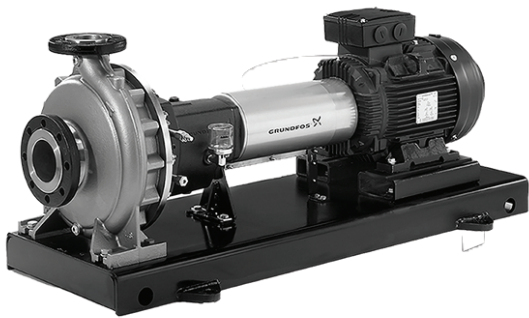

NK, NKE, NKG, NKGE

English (GB)

Service instructions	4
Appendix A	35

Original service instructions

Table of contents

1. General information	4
1.1 Hazard statements	4
1.2 Notes	4
1.3 Target group	4
2. Identification	5
2.1 Products covered by this Service instruction	5
2.2 Nameplate	5
2.3 Type key - NK, NKE, NKG, NKGE	7
3. Standard tools	14
4. Special tools	15
5. Disassembly and assembly	15
5.1 Disassembling the pump	15
5.2 Checking the gap between the impeller and the pump housing/cover (wear rings)	20
5.3 Assembling the pump	21
6. Reference information	27
6.1 Torque table	27
6.2 Recommended lubricants	27
6.3 Seal gap between impeller and pump housing/cover (wear rings)	27
6.4 Related documents	28
6.5 Service videos	28
7. Fault finding the product	29
8. Exploded drawings	31

1. General information



Read this document before you start service work on the product. Service work must comply with local regulations and accepted codes of good practice.

Observe the safety instructions in the installation and operating instructions for the product.

1.1 Hazard statements

The symbols and hazard statements below may appear in Grundfos installation and operating instructions, safety instructions and service instructions.

**DANGER**

Indicates a hazardous situation which, if not avoided, will result in death or serious personal injury.

**WARNING**

Indicates a hazardous situation which, if not avoided, could result in death or serious personal injury.

**CAUTION**

Indicates a hazardous situation which, if not avoided, could result in minor or moderate personal injury.

The hazard statements are structured in the following way:

**SIGNAL WORD****Description of the hazard**

Consequence of ignoring the warning

- Action to avoid the hazard.

1.2 Notes

The symbols and notes below may appear in Grundfos installation and operating instructions, safety instructions and service instructions.



Observe these instructions for explosion-proof products.



A blue or gray circle with a white graphical symbol indicates that an action must be taken.



A red or gray circle with a diagonal bar, possibly with a black graphical symbol, indicates that an action must not be taken or must be stopped.



If these instructions are not observed, it may result in malfunction or damage to the equipment.



Tips and advice that make the work easier.

1.3 Target group

These service instructions are intended for professional installers, operators and service technicians of the product.

We recommend that service and maintenance be carried out by skilled persons with technical qualifications required by the specific legislation in force.

2. Identification

2.1 Products covered by this Service instruction

	Range		
	IEC motor ¹⁾		NEMA motor ²⁾
	1	2	6
NB(E)	X		X
NBG(E)	X		
NBS(E)			X
NK(E)	X	X	X
NKG(E)	X		

- 1) The motors fitted with the pumps are according to the IEC standard (International Electrotechnical Commission) for frame size, dimensions and connecting interfaces (flange and shaft).
- 2) The motors fitted with the pumps are according to the NEMA standard (National Electrical Manufacturers Association - USA) for frame size, dimensions and connecting interfaces (flange and shaft).

2.2 Nameplate

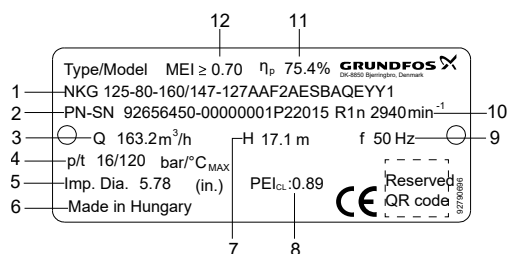

TM084201

Example of NKG nameplate

Pos.	Description
1	Type designation
2	Identification code
	92656450 Product number
	00000001 Serial number
	P22015 Production code - production site, year and week
	R1 Service range
3	Nominal flow rate
4	Pressure rating and maximum temperature
5	Actual impeller diameter
6	Country of origin
7	Nominal pump head
	Drinking water approval
	Or Pump Energy Index (PEI)
8	PEI _{CL} : constant load
	PEI _{VL} : variable load
9	Frequency
10	Rated pump speed
11	Hydraulic efficiency at best efficiency point
12	Minimum efficiency index

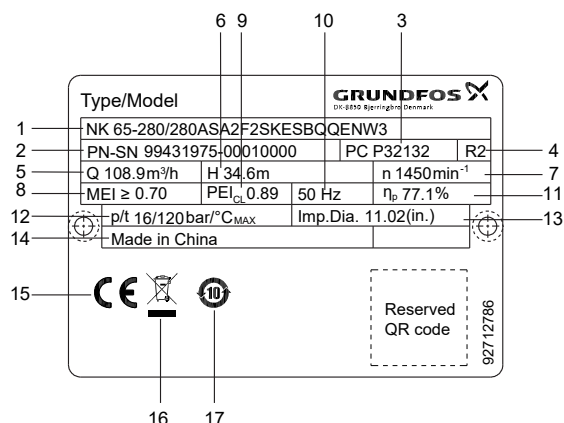

TM1040533

Example of NK nameplate

Pos.	Description
1	Type designation
2	Identification code
	99431975 Product number
	00010000 Serial number
3	Production code - production site, year and week
4	Range identification (service range code)
5	Nominal flow rate
6	Nominal pump head
7	Rated pump speed
8	Minimum efficiency index (MEI)
9	Pump Energy Index (PEI), constant load
10	Frequency
11	Hydraulic pump efficiency
12	Pressure rating and maximum temperature
13	Actual impeller diameter
14	Country of origin
15	CE mark
16	EU/WEEE mark
17	China RoHS mark

2.2.1 Looking up service parts in Grundfos Product Center

- Check the production code (PC code) on the nameplate before looking up service parts in Grundfos Product Center.
- The production code contains a year and week code which is used to ensure that correct service parts are selected.
 - Example 1: Pump has a year-week code 1748. This means that the pump is "produced after 1308" (and before 2053) The service parts list "produced after 1308" must be used.
 - Example 2: Pump has a year-week code 2142. This means that the pump is "Produced after 2053" and that this service parts list must be used.

This is used when new service part/s cannot be used on previous models.

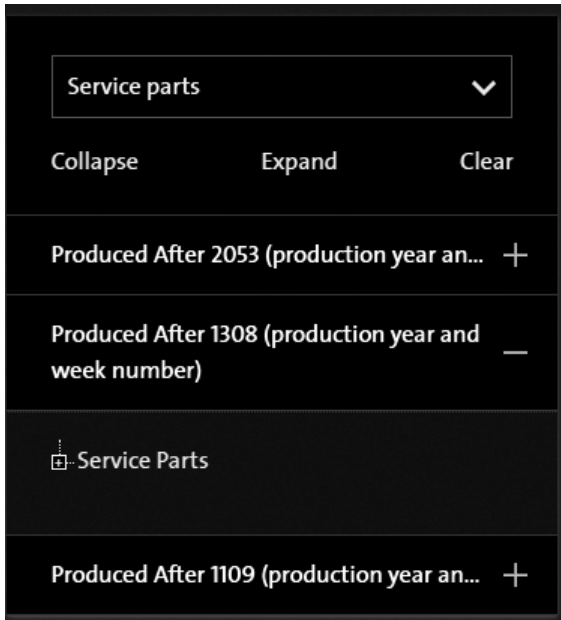

TM080702

Find your Grundfos Product Center here:



2.2.2 Looking up service parts in Service Kit Catalogue

Extra service information can be found in the Service Kit Catalogue compared to the service information in Grundfos Product Center - such as:

- Full overview of service architecture including material variants.
- Small kit exploded view drawings with position numbers explain the bill of material of the service parts in details.
- If service is not available when searching product PN in Grundfos Product Center, the service parts can be found by looking into the type designation.
- No need for internet access with physical catalogue. PDF file can be downloaded to smart devices.

Service Kit Catalogues can be found in Grundfos Product Center.

2.3 Type key - NK, NKE, NKG, NKGE

Example 1: NK 32-180/166AAEF2S3ESBQQEGX4

Example 2: NK 150-350/328-324AAEF2TBESBQQEWX4

Example 3: NKE 65-225/242ASA2F2SKESBQQENWA

Example 4: NKGE 125-100-250/275VACXEF1AESBQQELY1

Example 5: NKGE 125-100-160/160-140BSA1F2AESBAQERW1

Pos.	1	2	3	4	5	6	7	8	9	10	11	12	13	14	15	16	17	18
Example 1	NK		32	-180	/166		A		AE	F	2	S3	E	S	BQQE	G	X	4
Example 2	NK		150	-350	/328-324		A		AE	F	2	TB	E	S	BQQE	W	X	4
Example 3	NKE		65	-225	/242		A	S	A2	F	2	SK	E	S	BQQE	N	W	A
Example 4	NKGE	125	-100	-250	/275	V	A	C	XE	F	1	A	E	S	BQQE	L	Y	1
Example 5	NKGE	125	-100	-160	/160-140		B	S	A1	F	2	A	E	S	BAQE	R	W	1

Pos.	Explanation
1	Type range
2	Nominal diameter of inlet port (DN)
3	Nominal diameter of outlet port (DN)
4	Nominal impeller diameter [mm]
5	Actual impeller diameter [mm]
Impeller type	
	'blank': Closed impeller, cylindrical trim. If one dimension is shown, the impeller has a cylindrical trim, for example 219
6	'blank': Closed impeller, conical trim. If two dimensions are shown, the impeller has a conical trim, for example 160-140 S: Special open impeller V: Super vortex impeller
Hydraulic version	
	A: 1st version
7	B: 2nd version C: 3rd version D: 4th version
Sensor/motor version	
	'blank': Pump without sensor
	C: Without built-in sensor, one cable and one pressure sensor are supplied with the pump.
8	S: Pump with built-in differential-pressure sensor, Series 2000 G: Non -E pump/ -E pump with semi-integrated VFD/CUE: Motor with Grounding ring H: Non -E pump/ -E pump with semi-integrated VFD/CUE: Motor with hybrid bearing (HYB): Non drive-end I: Non -E pump/ -E pump with semi-integrated VFD/CUE: Motor with insulated bearing: Non drive-end
Code for pump version; the codes may be combined	
	A1: Basic version, grease-lubricated standard bearing design, standard coupling
	A2: Basic version, grease-lubricated standard bearing design, spacer coupling
	B: Oversize motor
	(+E): With ATEX approval, certificate or test report, the second character of the pump version code is an E
	G1: Grease-lubricated heavy-duty bearing design, standard coupling
	G2: Grease-lubricated heavy-duty bearing design, spacer coupling
	H1: Oil-lubricated heavy-duty bearing design, standard coupling
	H2: Oil-lubricated heavy-duty bearing design, spacer coupling
9	I1: Pump without motor, grease-lubricated standard bearing design, standard coupling I2: Pump without motor, grease-lubricated standard bearing design, spacer coupling J1: Pump without motor, grease-lubricated heavy-duty bearing design, standard coupling J2: Pump without motor, grease-lubricated heavy-duty bearing design, spacer coupling K1: Pump without motor, oil-lubricated heavy-duty bearing design, standard coupling K2: Pump without motor, oil-lubricated heavy-duty bearing design, spacer coupling Y1: Bare shaft pump, grease-lubricated standard bearing design W1: Bare shaft pump, grease-lubricated heavy-duty bearing design Z1: Bare shaft pump, oil-lubricated heavy-duty bearing design X: Special version; used in case of further customisation than already listed
Pipe connection	
	E: Table E flange
10	F: DIN flange G: ANSI flange J: JIS flange

Pos.	Explanation
	Flange pressure rating (PN - rated pressure)
	1: 10 bar
	2: 16 bar
11	3: 25 bar
	4: 40 bar
	5: Other pressure rating

Pos.	Explanation				
	Code for materials				
	Code	Pump housing	Impeller	Wear ring	Shaft
	A	EN-GJL-250	EN-GJL-200	Bronze/brass	1.4021/1.4034
	B	EN-GJL-250	Bronze CuSn10	Bronze/brass	1.4021/1.4034
	C	EN-GJL-250	EN-GJL-200	Bronze/brass	1.4401
	D	EN-GJL-250	Bronze CuSn10	Bronze/brass	1.4401
	E	EN-GJL-250	EN-GJL-200	EN-GJL-250	1.4021/1.4034
	F	EN-GJL-250	Bronze CuSn10	EN-GJL-250	1.4021/1.4034
	G	EN-GJL-250	EN-GJL-200	EN-GJL-250	1.4401
	H	EN-GJL-250	Bronze CuSn10	EN-GJL-250	1.4401
	I	1.4408	1.4408	1.4517	1.4462
	J	1.4408	1.4408	Carbon-graphite-filled PTFE (Graflon®)	1.4462
	K	1.4408	1.4408	1.4517	1.4401
	L	1.4517	1.4517	1.4517	1.4462
	M	1.4408	1.4517	1.4517	1.4401
	N	1.4408	1.4408	Carbon-graphite-filled PTFE (Graflon®)	1.4401
	P	1.4408	1.4517	Carbon-graphite-filled PTFE (Graflon®)	1.4401
	R	1.4517	1.4517	Carbon-graphite-filled PTFE (Graflon®)	1.4462
	S	EN-GJL-250	1.4408	Bronze/brass	1.4401
	T	EN-GJL-250	1.4517	Bronze/brass	1.4462
	U	1.4408	1.4517	1.4517	1.4462
	W	1.4408	1.4517	Carbon-graphite-filled PTFE (Graflon®)	1.4462
	Z	1.4469	1.4469	1.4410	1.4410
	QA	EN-GJL-250	Bronze CuSn10	No wear ring	1.4301 + 1.0503
12	QB	EN-GJL-250	Bronze CuSn10	No wear ring	1.4401
	QC	EN-GJL-250	Bronze CuSn10	No wear ring	1.4462
	QD	EN-GJL-250	Bronze CuSn10	No wear ring	1.4410
	QE	EN-GJS-500-7 ductile	Bronze CuSn10	No wear ring	1.4301 + 1.0503
	QF	EN-GJS-500-7 ductile	Bronze CuSn10	No wear ring	1.4401
	QG	EN-GJS-500-7 ductile	Bronze CuSn10	No wear ring	1.4462
	QH	EN-GJS-500-7 ductile	Bronze CuSn10	No wear ring	1.4410
	S3	EN-GJL-250	1.4308	No wear ring	1.4301 + 1.0503
	S4	EN-GJL-250	1.4308	No wear ring	1.4401
	S5	EN-GJL-250	1.4308	No wear ring	1.4462
	S8	EN-GJL-250	1.4408	No wear ring	1.4401
	S9	EN-GJL-250	1.4408	No wear ring	1.4462
	SB	EN-GJS-500-7 ductile	1.4308	No wear ring	1.4301 + 1.0503
	SC	EN-GJS-500-7 ductile	1.4308	No wear ring	1.4401
	SD	EN-GJS-500-7 ductile	1.4308	No wear ring	1.4462
	SG	EN-GJS-500-7 ductile	1.4408	No wear ring	1.4401
	SH	EN-GJS-500-7 ductile	1.4408	No wear ring	1.4462
	SI	EN-GJS-500-7 ductile	1.4308	No wear ring	1.4410
	SJ	EN-GJS-500-7 ductile	1.4408	No wear ring	1.4410
	SK	EN-GJL-250	1.4308	No wear ring	1.4410
	SL	EN-GJL-250	1.4408	No wear ring	1.4410
	T2	EN-GJL-250	1.4517	No wear ring	1.4462
	T3	EN-GJL-250	1.4517	No wear ring	1.4410
	TA	EN-GJS-500-7 ductile	1.4517	No wear ring	1.4462
	TB	EN-GJS-500-7 ductile	1.4517	No wear ring	1.4410
	X	Special version			

Pos. Explanation**Rubber parts in pump**

E: EE

F: FF

G: FE

H: KE

I: KM

J: KV

K: KK

M: MN

N: ME

O: OO

V: VV

- 13
- The first letter indicates material of elastomer between pump housing and cover, and elastomer between cover and split cover.
 - The second letter indicates material of elastomer between split cover and seal housing.

See the material description in the table below.

Code	Material description
E	EPDM
F	FXM (Fluoraz [®])
K	FFKM (Kalrez [®])
M	FEPS (PTFE-sheathed silicone O-ring)
O	HNBR
V	FKM (Viton [®])

Shaft seal arrangement

B: Stuffing box

C: Cartridge seal, single

- 14

D: Cartridge seal, double

O: Back-to-back, double seal

P: Tandem, double seal

S: Single seal

Shaft seal(s) in pump

Letter or digit code for mechanical shaft seal and shaft seal rubber parts

- 15
- 4 letters: Single mechanical shaft seal, such as BQQE, or single cartridge seal, such as HBQV
 - 4 digits:
 - double seal solution; example 2716, where 27 is DQQV, primary seal, and 16 is BQQV, secondary seal;
 - double cartridge seal; example 5150, where 51 is HQQU, primary seal, and 50 is HBQV, secondary seal

The relation between letters and digits of the shaft seals is described in Codes for shaft seals.

- 16 Code for rated motor power [kW]. See Codes for rated motor power.

- 17 Code for DOE identification. See Code for DOE identification.

- 18 Code for speed variant [rpm]. See Codes for speed variant.

Example 1: NK 32-180/166AAEF2S3ESBQQEGX4 shows an NK 32-180 pump with these characteristics:

- 166 mm closed impeller, cylindrical trim
- hydraulic version A
- pump without sensor
- grease-lubricated standard bearing design
- with certificate/report (with standard coupling)
- DIN flange to EN1092-2
- 16 bar flange pressure rating
- cast iron pump housing, EN-GJL-250
- stainless steel impeller, 1.4308
- no wear ring
- stainless steel shaft, 1.4301
- EPDM O-rings for pump cover and seal cover
- single shaft seal arrangement
- BQQE shaft seal
- 1.1 kW motor, no motor or US DOE Regulated Motor (CC marked motor), 4-pole, 60 Hz.

Example 2: NK 150-350/328-324AAEF2TBESBQQEWX2 shows an NK 150-350 pump with these characteristics:

- 328-324 mm closed impeller, conical trim
- hydraulic version A
- pump without sensor
- grease-lubricated standard bearing design
- with certificate/report (with standard coupling)
- DIN flange to EN1092-2
- 16 bar flange pressure rating
- ductile iron pump housing, EN-GJS-500-7
- duplex stainless steel impeller, 1.4517
- no wear ring
- super duplex stainless steel shaft, 1.4410
- EPDM O-rings for pump cover and seal cover
- single shaft seal arrangement
- BQQE shaft seal
- 90 kW motor, no motor or US DOE Regulated Motor (CC marked motor), 2-pole, 60 Hz.

Example 3: NKE 65-225/242ASA2F2SKESBQQENWA shows an NKE 65-225 pump with these characteristics:

- 242 mm closed impeller, cylindrical trim
- hydraulic version A
- Built-in differential-pressure sensor, Series 2000
- grease-lubricated standard bearing design
- spacer coupling
- DIN flange to EN1092-2
- 16 bar flange pressure rating
- cast iron pump housing, EN-GJL-250
- stainless steel impeller, 1.4308
- no wear ring
- super duplex stainless steel shaft, 1.4410
- EPDM O-rings for pump cover and seal cover
- single shaft seal arrangement
- BQQE shaft seal
- 11 kW motor, not for sale in North American, 1450-2200 rpm.

Example 4: NKGE

125-100-250/275VACXEF1AESBQQELY1 shows an NKGE 125-100-250 pump with these characteristics:

- 275 mm Super Vortex impeller
- hydraulic version A
- without built-in sensor, one cable and one pressure sensor are supplied with the pump.
- special version with certificate/report (with standard coupling)
- DIN flange to EN 1092-2 pipe connection
- 10 bar flange pressure rating
- cast iron pump housing, EN-GJL-250
- cast iron impeller, EN-GJL-200
- bronze/brass wear ring
- stainless steel shaft, EN 1.4021/1.4034
- EPDM O-rings for pump cover and seal cover
- single shaft seal arrangement
- BAQE shaft seal
- 5.5 kW motor, out of DOE scope, 2-pole, 50 Hz.

Example 5: NKGE

125-100-160/160-140BSA1F2AESBAQERW1 shows an NKGE 125-100-160 pump with these characteristics:

- 160-140 mm closed impeller, conical trim
- hydraulic version B
- with built-in differential-pressure sensor
- grease-lubricated standard bearing design
- standard coupling
- DIN flange to EN 1092-2 pipe connection
- 16 bar flange pressure rating
- cast iron pump housing, EN-GJL-250
- cast iron impeller, EN-GJL-200
- bronze/brass wear ring
- stainless steel shaft, EN 1.4021/1.4034
- EPDM O-rings for pump cover and seal cover
- single shaft seal arrangement
- BAQE shaft seal
- 30 kW motor, not for sale in North America, 2-pole, 50 Hz.

2.3.1 Codes for shaft seals

The digits are only used for double shaft seal solutions.

Digits	Letters	Description
10	BAQE	Single mechanical shaft seal
12	BBQE	Single mechanical shaft seal
13	BBQV	Single mechanical shaft seal
15	BQQE	Single mechanical shaft seal
16	BQQV	Single mechanical shaft seal
19	AQAE	Single mechanical shaft seal
20	AQAV	Single mechanical shaft seal
21	AQQE	Single mechanical shaft seal
22	AQQV	Single mechanical shaft seal
23	AQQX	Single mechanical shaft seal
24	AQQK	Single mechanical shaft seal
25	DAQF	Single mechanical shaft seal
26	DQQE	Single mechanical shaft seal
27	DQQV	Single mechanical shaft seal
28	DQQX	Single mechanical shaft seal
29	DQQK	Single mechanical shaft seal
50	HBQV	Cartridge seal
51	HQQU	Cartridge seal
52	HAQK	Cartridge seal
	SNEA	Stuffing box
	SNEB	Stuffing box
	SNEC	Stuffing box
	SNED	Stuffing box
	SNOA	Stuffing box
	SNOB	Stuffing box
	SNOC	Stuffing box
	SNOD	Stuffing box
	SNFA	Stuffing box
	SNFB	Stuffing box
	SNFC	Stuffing box
	SNFD	Stuffing box

2.3.2 Letter codes for shaft seals

Pos. 14 in NK, NKE, NKG, NKGE type key example.

Code	Description	Explanation
B	Shaft seal type	A: O-ring seal with fixed driver B: Rubber bellows seal D: O-ring seal, balanced H: Cartridge seal, balanced
Q	Material of rotating seal face	A: Carbon, metal-impregnated with antimony which is not approved for potable water B: Carbon, resin-impregnated Q: Silicon carbide
Q	Material of stationary seal	A: Carbon, metal-impregnated with antimony which is not approved for potable water Q: Silicon carbide
E	Material of secondary seal and other rubber and composite parts, except the wear ring	E: EPDM V: FKM (Viton®) F: FXM (Fluoraz®) K: FFKM (Kalrez®) X: HNBR U: Dynamic O-rings in FFKM and static O-rings in PTFE

For a thorough description of shaft seal types and materials, see the data booklet "NB, NBG, NK, NKG, NBE, NBGE, NKE, NKGE - Custom-built pumps according to EN 733 and ISO 2858".

2.3.3 Codes for rated motor power

Pos. 15 in NK, NKE, NKG, NKGE type key example.

Code	Description	
	[hp]	[kW]
A	0.16	0.12
B	0.25	0.18
C	0.33	0.25
D	0.5	0.37
E	0.75	0.55
F	1	0.75
G	1.5	1.1
H	2	1.5
I	3	2.2
J	4	3
K	5 (5.5 ³⁾)	3.7 (4 ³⁾)
L	7.5	5.5
M	10	7.5
N	15	11
O	20	15
P	25	18.5
Q	30	22
R	40	30
S	50	37
T	60	45
U	75	55
V	100	75
W	125	90
X	Bare shaft pump	
Y	> 200 ⁴⁾	> 150 ⁴⁾
1	150	110
2	175	132
3	200	150
4	215 ⁵⁾	160 ⁵⁾
5	250 ⁵⁾	185 ⁵⁾
6	-	26

3) Value in bracket is for the standard IEC motor size. Value outside bracket is for the motor size according to NEMA standards.

4) Used for pumps where the pump shaft input power exceeds 200 hp (150 kW) and is not regulated under the DOE pump rule.

5) Special cases with power sizes above 200 hp (150 kW) which are still regulated under the DOE pump rule. For example: Pump has a P2 value of 198 hp (147.6 kW) in its duty point (in DOE scope) but customer wants the 215 hp (160 kW) motor instead of the 200 hp (150 kW). The pump is in scope of the DOE regulation and requires a PEI value and a motor code.

2.3.4 Code for DOE identification

Pos. 16 in NK, NKE, NKG, NKGE type key example.

Code	Description
A	DOE reported with E-motor (ECM ⁶⁾), 1 × 200-240 V
B	DOE reported with E-motor (ECM ⁶⁾), 3 × 200-240 V
C	DOE reported with E-motor (ECM ⁶⁾), 3 × 440-480 V
D	DOE reported with E-motor (ECM ⁶⁾), 3 × 380-500 V
E	DOE reported with E-motor (ECM ⁶⁾), 3 × 525-690 V
W	In DOE scope but not compliant with or out of DOE scope but not for sale in North America
X	DOE reported, sell as bare shaft pump or DOE regulated Motor (CC marked motor)
Y	Pumps not subject to the DOE regulation, and can be sold in North America
Z	DOE reported with Asynchronous E-Motor

6) ECM: Electronically Commutated Motor.

2.3.5 Codes for speed variant

Pos. 17 in NK, NKE, NKG, NKGE type key example.

Code	Description
A	1450-2200 RPM, E-motor (ECM ⁷⁾)
B	2900-4000 RPM, E-motor (ECM ⁷⁾)
C	4000-5900 RPM, E-motor (ECM ⁷⁾)
D	1450-2200 RPM, CUE + PM motor
E	2900-4000 RPM, CUE + PM motor
1	2-pole, 50 Hz (Asynchronous motor)
2	2-pole, 60 Hz (Asynchronous motor)
3	4-pole, 50 Hz (Asynchronous motor)
4	4-pole, 60 Hz (Asynchronous motor)
5	6-pole, 50 Hz (Asynchronous motor)
6	6-pole, 60 Hz (Asynchronous motor)
7	8-pole, 50 Hz (Asynchronous motor)
8	8-pole, 60 Hz (Asynchronous motor)

7) ECM: Electronically Commutated Motor.

3. Standard tools

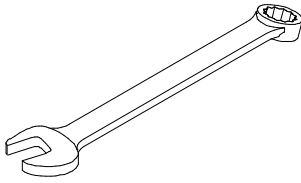

Ring/open-end spanner

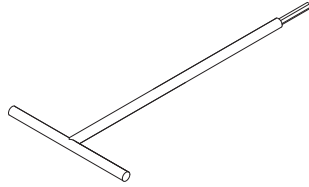

Hexagon T-key

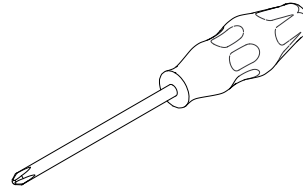

Cross-recess screwdriver

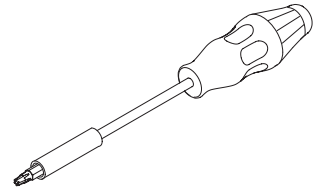

Reversible-bit screwdriver

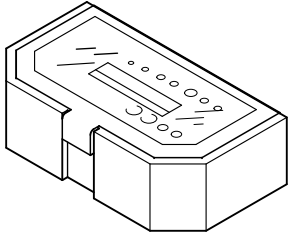

Bits kit

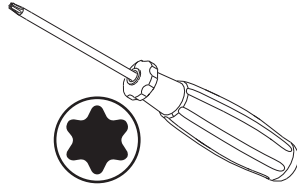

Torx Screwdriver

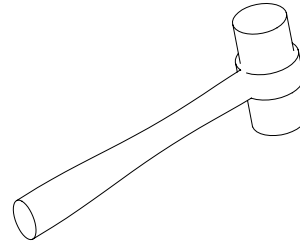

Plastic hammer

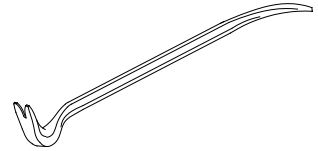

Pry bar

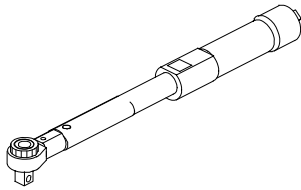

Torque wrench

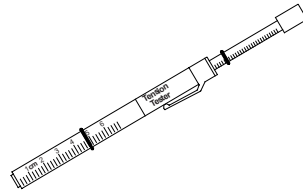

Gauge for inner diameter measurement of wear ring

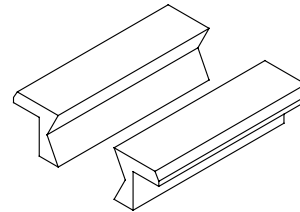

Soft jaws

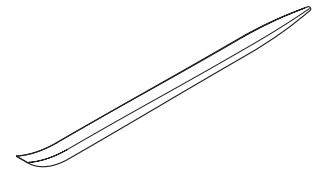

Pinch bar

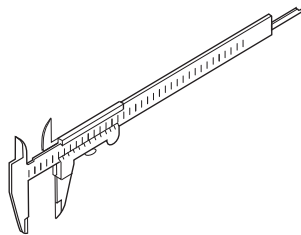

Sliding gauge

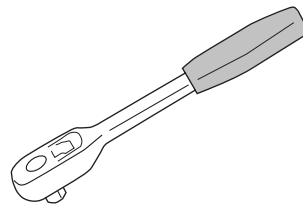

Ratchet spanner with socket

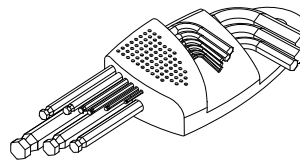

Hexagon key set

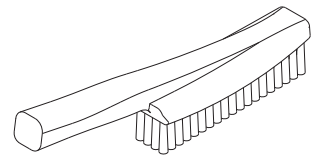

Steel brush

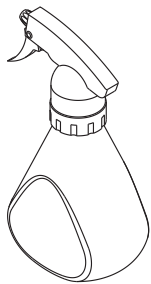

Sprayer

4. Special tools

You can manufacture your own special tools. See descriptions in Appendix A or follow the links with the illustrations.

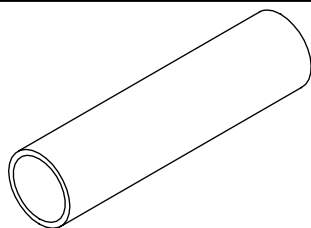

Punch for shaft seal

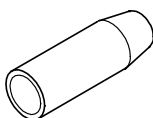

Protective tool



Positioning tool

5. Disassembly and assembly

WARNING Overhead load



Death or serious personal injury

- Pay attention to the pump weight and take precautions to prevent personal injury if the pump topples or falls by accident.

CAUTION Crushing of feet



Minor or moderate personal injury

- Do not drop pump components when servicing the product.

Check also the following service videos in association with this task:

Related information

3. Standard tools
4. Special tools

5.1 Disassembling the pump

1. Find the service tools listed in section Service tools.



2. Use the nameplate to search out correct service parts.



3. Remove the coupling guard to gain access.



TM083823

4. Measure outside coupling diameter.



TM083824

TM083822

TM083821

5. Measure the air gab between the pump hub and the driver.

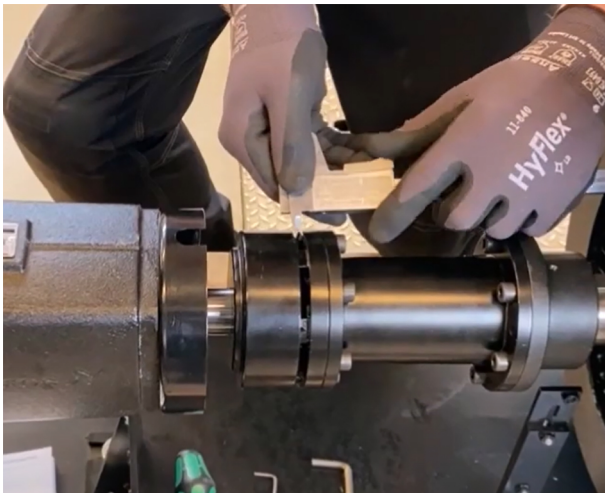

TM083825

8. Remove the spacer ring and the spacer.

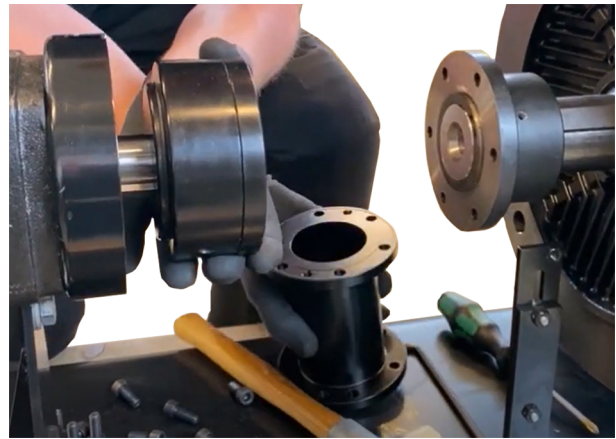

TM083828

6. Refer to the table below to make sure that the air gap is correct.

Outside coupling diameter [mm]	Air-gap width S2 [mm]			
	Standard coupling		Spacer coupling	
	Nominal	Tolerance	Nominal	Tolerance
80			4	
95	-	-	4	
110			4	
125			4	
140			4	0/-1
160	4	0/-1	4	
200			6	
225			6	
250			8	

7. Loosen the spacer from the hubs.

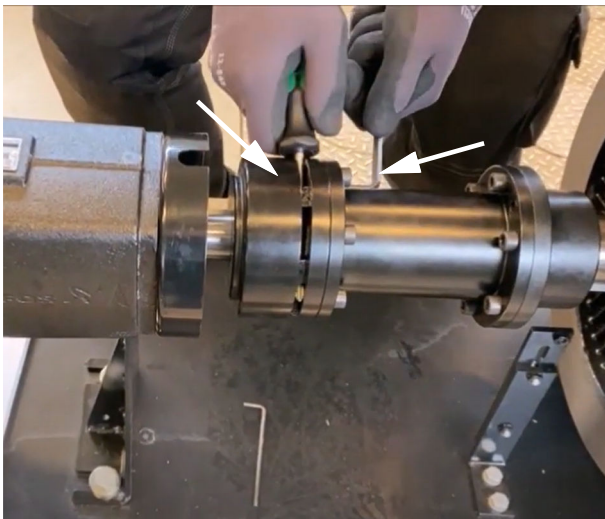

TM083827

9. Loosen the set screw and remove the pump hub.

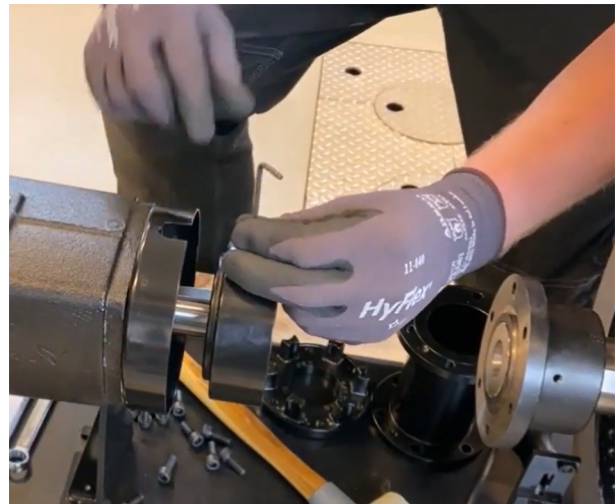

TM083829

10. Loosen and remove the shaft guard.

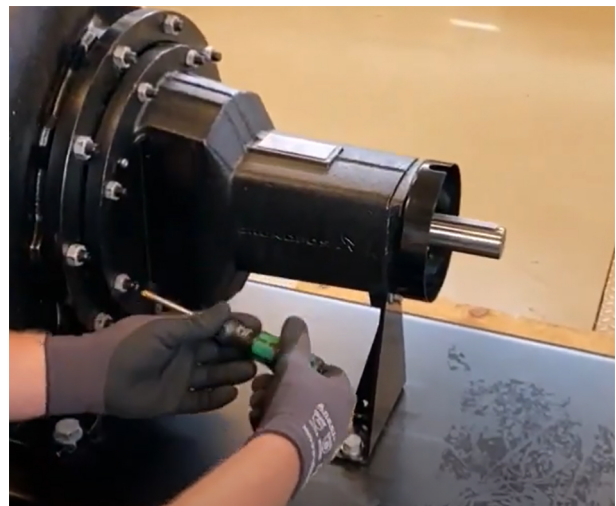

TM083830



Use a screwdriver to hold the coupling.

11. Loosen the bearing bracket foot.



TM083831

14. Use a strap wrench to secure the impeller and loosen the impeller.

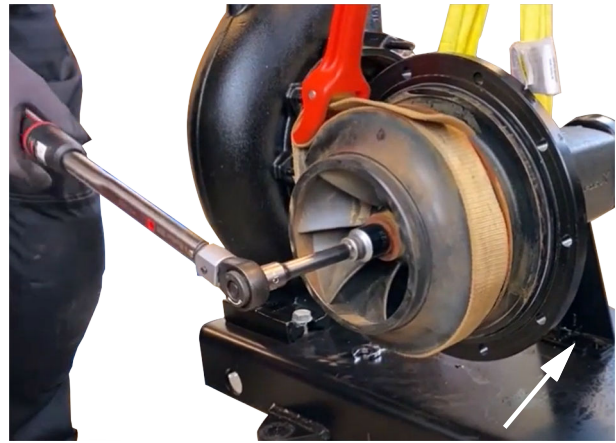

TM083834



Fixate the bearing bracket foot to ease dismantling of the impeller.

12. Loosen the cover from pump housing.



TM083832

15. Use pinch bars to loosen the impeller.



TM083835

13. Use pinch bars to loosen the bearing bracket and the cover from the pump housing.



TM083833

16. Remove the shaft key and the spacer.



TM083836



Make support for the bearing bracket with a suitable lifting device.

17. Use pinch bars to remove the rotating part of the shaft seal.

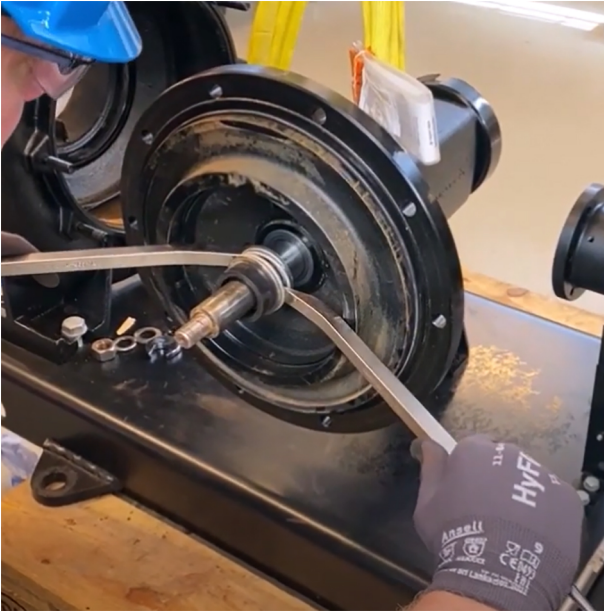

TM083837

19. Push out the stationary part of the shaft seal.

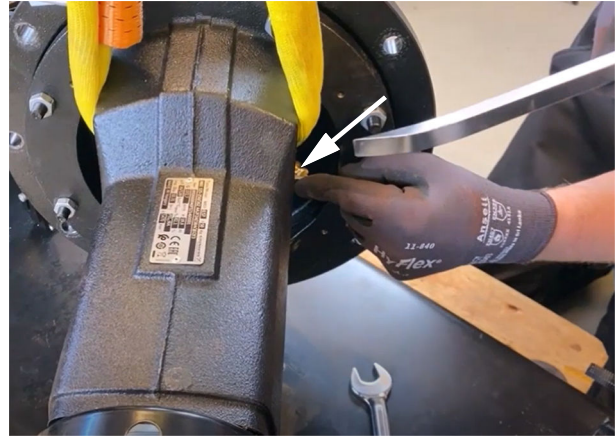

TM083839

18. Check conditions of the spring, and seal face.



TM083838

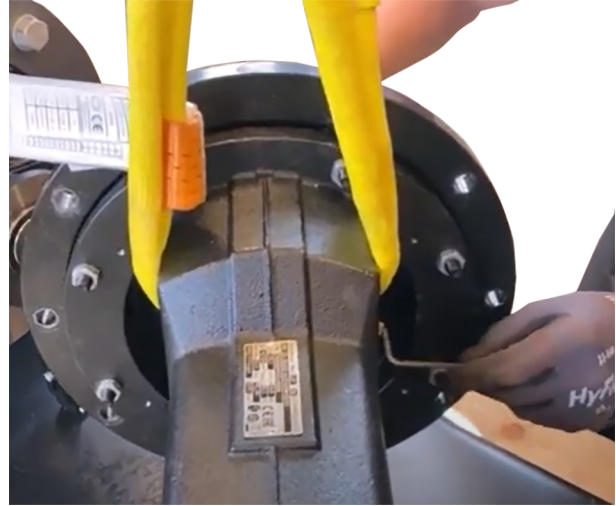

TM083946



Use an allen key and a pinch bar to loosen the stationary part of the shaft seal from outer side of the cover.



Make sure that you do not touch the seal surface.

20. Loosen and remove the coupling guard retainer.



TM083840

21. Loosen the bearing cover and remove the V-ring and lock ring.



TM083841

22. Catch the V-ring when removing the shaft with bearings.

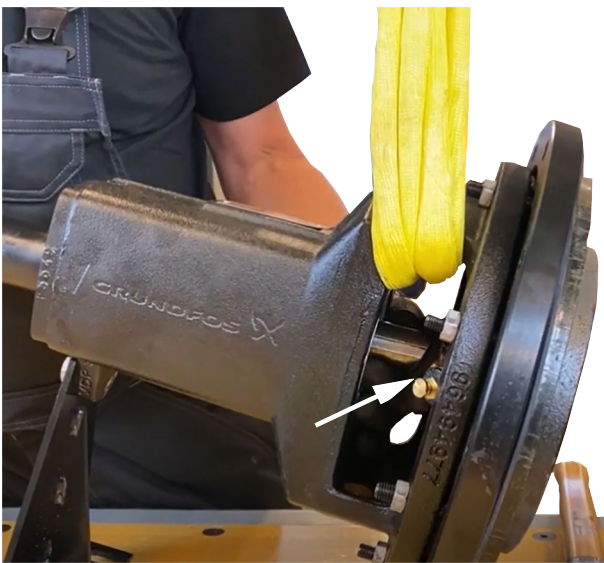

TM083842

23. Remove the O-rings.

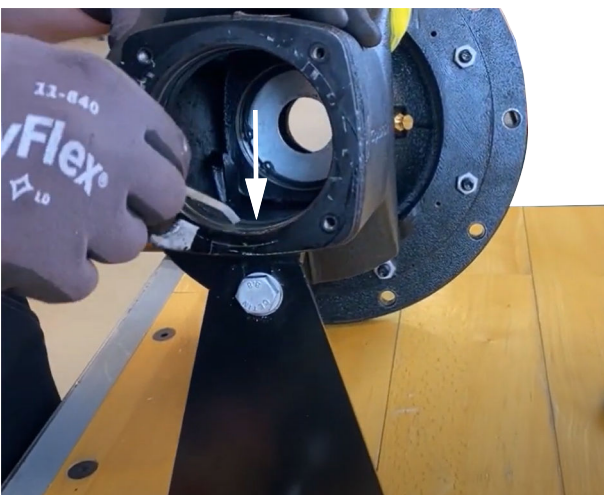

TM083843



Bend a soft cable strip to catch the O-ring inside the bearing bracket.

24. Use a puller to extract the bearings from the shaft.



TM083844



Fit soft jaws to the vice to avoid damaging the shaft.

25. Before assembling new bearings, heat up the bearings to 100 °C with a bearing heater.



TM083845

26. Fit the preheated bearings to the shaft.



TM083846

27. Check condition and cleanliness of the recess for the cover and O-rings

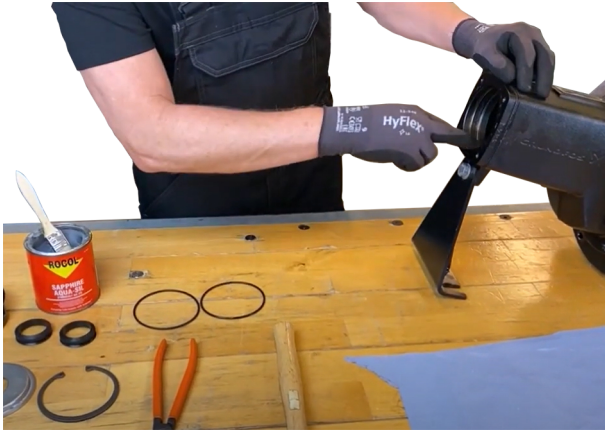

TM083847



Use locally approved lubricants (example: Rocol sapphire aqua SIL).

28. Fit the V-ring in the right position when assembling the shaft with bearings.

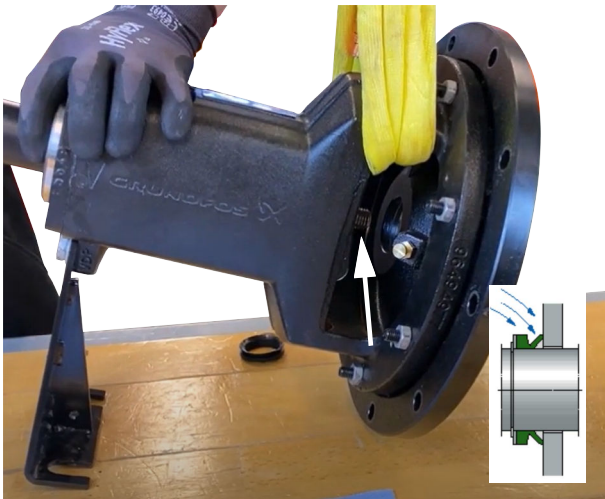

TM083848

29. Assemble the lock ring, cover and V-ring.



TM083849



Use locally approved lubricants (example: Rocol sapphire aqua SIL).

30. Assemble the coupling guard retainer.



TM083850

31. Tighten coupling guard retaining screws. See section 6.1 Torque table.

5.2 Checking the gap between the impeller and the pump housing/cover (wear rings)

1. Measure and note the diameter of the impeller and cover interfaces.

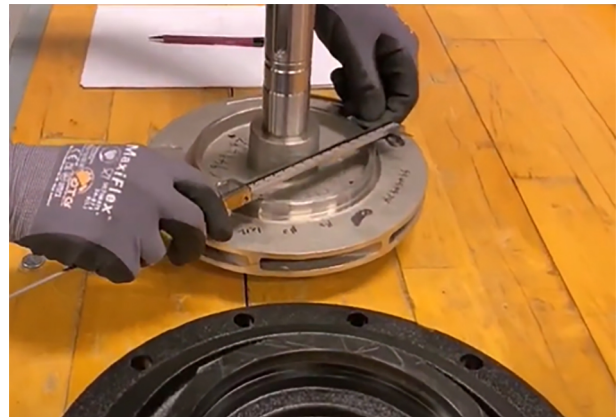

TM083552



Two measurements must be made (positions 12-6 and 3-9). The wear ring may be worn oval due to different directions of radial forces.

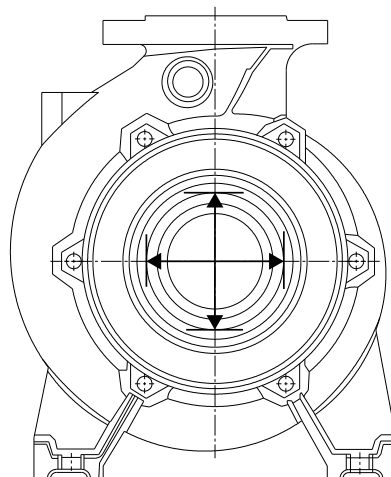

TM080471

2. Measure and note the diameter of the pump housing interface to the impeller.

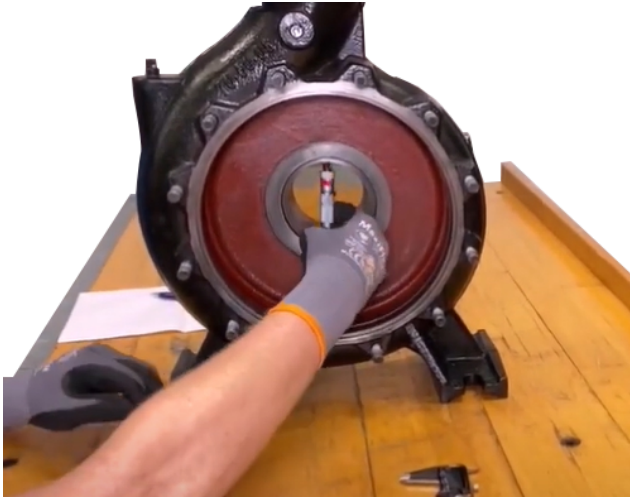

TM083553

3. Measure and note the impeller interface to the pump housing.



For maximum gap values, check the illustrated service instruction.



TM083513

Related information

[6.3 Seal gap between impeller and pump housing/cover \(wear rings\)](#)

5.3 Assembling the pump

1. Check condition and cleanliness of the shaft and the cover.



TM083851

2. Assemble the stationary seal part.



TM083852



Use locally approved thread lubricants (example: Rocol sapphire aqua SIL).



Make sure that you do not touch the seal surface.

3. Use a soft tool to position the stationary seal part.



TM083853

4. Lubricate the seal face with soapy water.

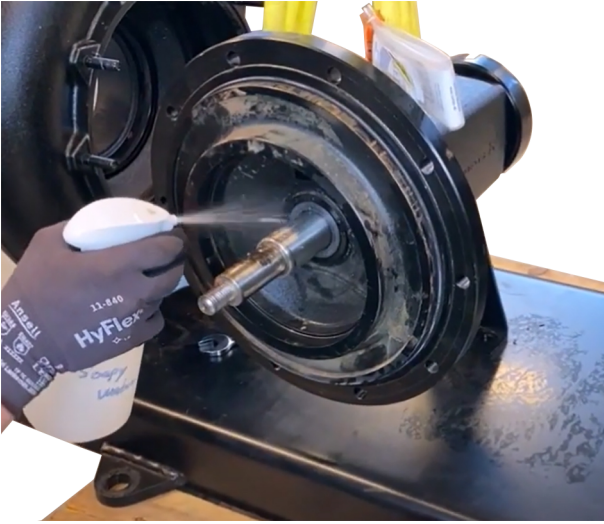

TM083854

! Shaft seal face combination xQQx (siliconcarbide-siliconcarbide) must never run dry.

5. Lubricate the rotating seal part with soapy water and assemble the rotating seal part by using a soft punch tool.

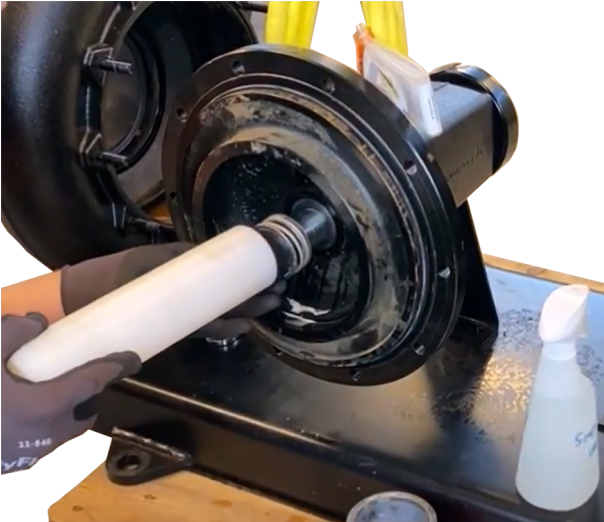

TM083855

⊘ Make sure that you do not touch the seal surface.

6. Use the spacer (if installed) to secure the position of the rotating seal part.



TM083856

7. Check condition and cleanliness of the shaft and impeller interfaces. Polish rusted surfaces using an emery cloth or steel brush.



TM083857

! Use locally approved lubricants (example: Never Seez).

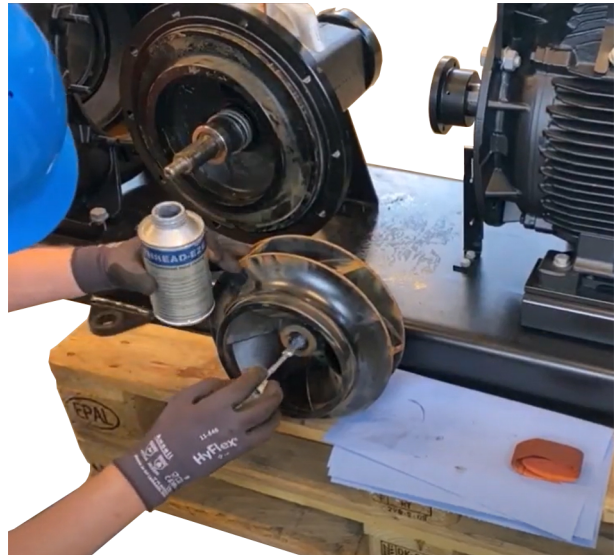

TM083858

8. Assemble the shaft key and the impeller without using excess force.



TM083859

10. Polish rusted surfaces using an emery cloth or steel brush.



TM083871



Assembly sequence - washer, spring washer and nut.

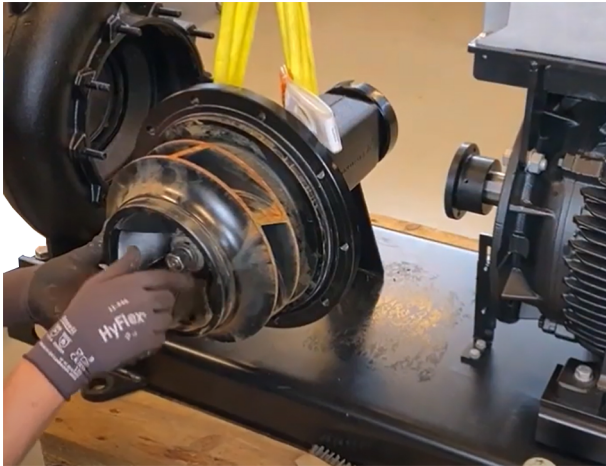

TM083860



TM083872



Use locally approved lubricants (example: Rocol sapphire aqua SIL).

9. Use a strap wrench to secure the impeller. Tighten the impeller nut. See section 6.1 Torque table.



TM083870

12. Assemble the nuts for the bearing bracket (cover) and make a loose tightening.

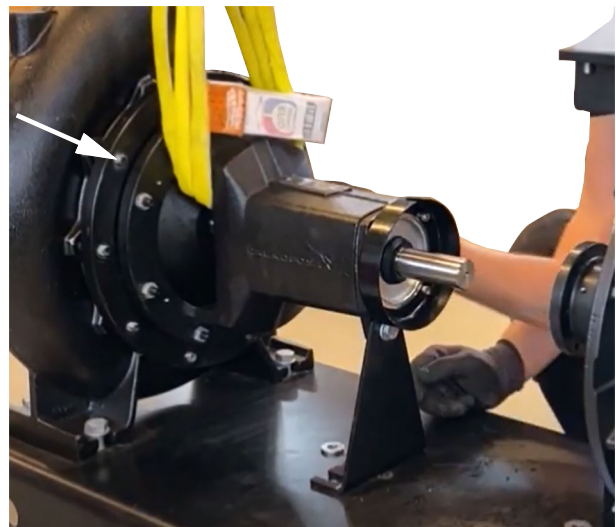

TM083873

13. Assemble the screws for the bearing bracket foot and make a loose tightening.



TM083874



Use locally approved lubricants (example: Never Seez).

14. Tighten cover nuts. See section 6.1 *Torque table*.



TM083876

15. Tighten the bearing foot screws. See section 6.1 *Torque table*.

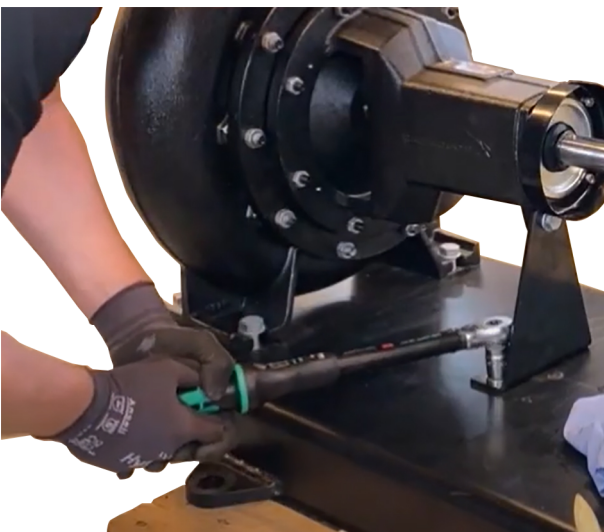

TM083877

16. Rotate the shaft to make sure that the shaft runs freely with no rub.



TM083875

17. Check condition of the coupling rubber. If it is hard and cracks when bended - replace it.



TM083878

18. Check that the spacer ring moves freely in the rubber parts.



TM083879

19. Prepare assembly of the spacer coupling. Lubricate screws.



TM083880



Use locally approved thread lubricants (example Never Seez).

20. Make sure that the set screw does not interfere with the shaft key.



TM083881

21. Make the pump hub flush with the shaft end.



TM083882

22. Assemble the spacer ring and the spacer.



TM083883



Prevent shaft rotation by securing the shaft with a screwdriver in the spacer ring.



If it is not possible to use a torque tool, tighten until resistance + 15 degrees.

23. Adjust the gap according to the specification in Installation and operating instructions (I/O).

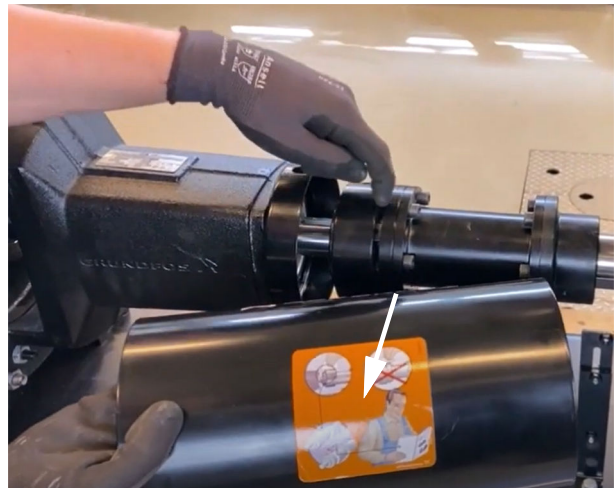

TM083884



Use an allen key with the right thickness to adjust the gab.



TM083885

24. Tighten the set screw for the pump hub.



TM083886



If it is not possible to use a torque tool, tighten until resistance + 15 degrees.

25. Assemble coupling guards.



TM083887



Fixate the inner part of the coupling part with tape.

26. Tighten the coupling guard manually and make sure that the retainer and the coupling guard inner part are not deformed.



TM083888

27. Assemble the shaft guards.

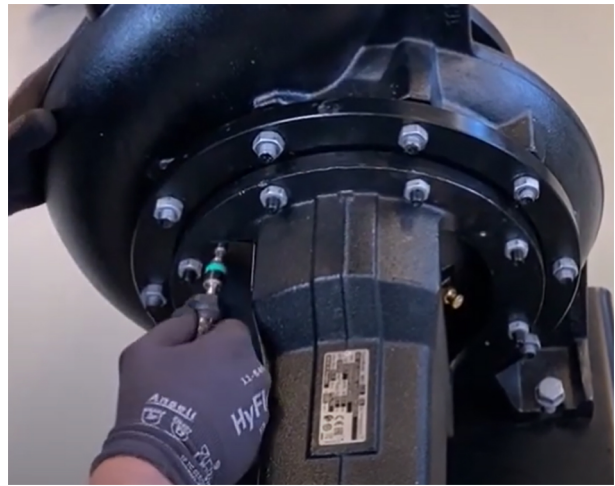

TM083889

28. Tighten the shaft guard screws. See section 6.1 Torque table.

NOTE! Laser alignment – see video on Grundfos YouTube channel or find instructions/video on Grundfos Product Center.



6. Reference information

6.1 Torque table

Impeller nuts

Nut	Torque [Nm]
M12	41 +/- 4
M14	65 +/- 7
M18	120 +/- 10
M24	300 +/- 35
M27	300 +/- 35

Pump cover nuts

Nut	Torque [Nm]
M10	45 +/- 9
M12	80 +/- 16
M16	145 +/- 30

Motor stool/pump housing nuts

Nut	Torque [Nm]
M10	40 +/- 8
M1	70 +/- 15
M16	145 +/- 30

Motor stool/motor bolts

Bolt	Torque [Nm]
1/2"	70 +/- 10
5/8"	150 +/- 15

Seal cover screws

Screw	Torque [Nm]
M8	24 +/- 2.4
M10	45 +/- 9

Coupling screws

Screw	Torque [Nm]
M10	85 +/- 8.5
M12	90 +/- 9

Coupling key set screws

Screw	Torque [Nm]
M4	5 +/- 2
M	9 +/- 2
M8	12 +/- 2

Related information

[5.3 Assembling the pump](#)

6.2 Recommended lubricants

- Elastomer Lubricant Vegetable Glycerin
- Anti-seize compound, food grade

6.3 Seal gap between impeller and pump housing/cover (wear rings)

A leak flow (1) will occur in gap (2) between the rotating impeller and the stationary pump housing when the pump is operating. Leak flow (1) returns to impeller inlet (3) through gap (2).

Thus, the impeller must pump both leak flow (1) and the fluid through the pump from inlet (3) flange to outlet (4) flange. To minimize leak flow (1), an interchangeable wear ring (impeller seal) (A) is mounted.

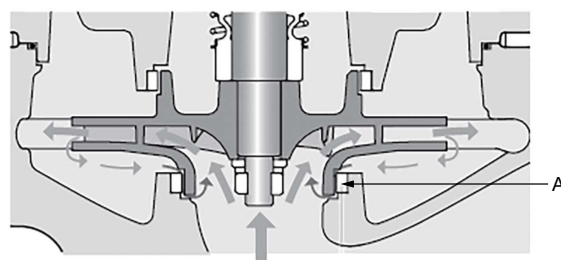
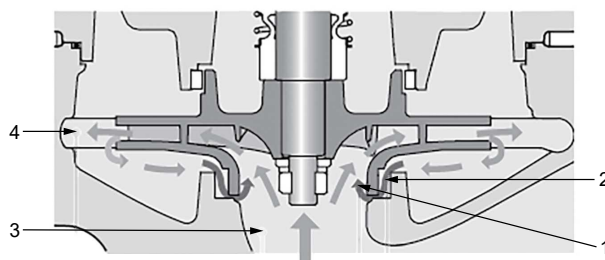

TM080466

We recommend that the seal gap never exceeds the maximum limit curve calculated according to an efficiency loss of maximum 2 %.

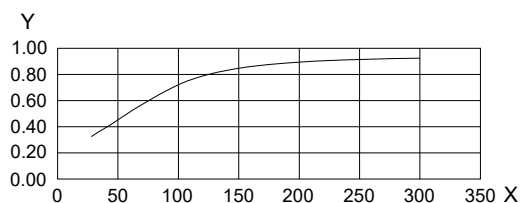

TM080467

X	Outlet DN
Y	Maximum seal gap [mm]

Recommended wear-tolerance specifications:

The above curve indicates recommended maximum seal gap in relation to pump outlet DN. The below table list the reference dimension of WR/PH and IMP as well as the recommended maximum seal gap. If the measured seal gap exceeds maximum values, it is recommended to replace the worn parts. The reference dimension support determining which part to replace.

Reference WR/PH inside - IMP outside (mm)	Seal gap	
	Gap complete (mm)	
	WR/PH in SS and IMP in SS	
63	1	1.3
76	1	1.3
90	1	1.3
100	1	1.3
112	1	1.3
122	1.2	1.5
130	1.2	1.5
144	1.2	1.5
154	1.2	1.5
174	1.2	1.5

Seal gap		
Reference WR/PH inside - IMP outside (mm)	Gap complete (mm)	
	WR/PH in SS and IMP in SS	
185	1.2	1.7
200	1.4	1.7
210	1.4	1.7
222	1.4	1.7
224	1.4	1.7
230	1.4	1.7
240	1.4	1.7
250	1.4	1.7
260	1.4	1.7

Abbreviation

WR	Wear ring
PH	Pump house
IMP	Impeller
CI	Cast iron

Related information

[5.2 Checking the gap between the impeller and the pump housing/cover \(wear rings\)](#)

6.4 Related documents

You can find further product information on grundfos.com about:

- NK, NKE, NKG, NKGE



- LS



6.5 Service videos

You can find video instructions for the service of NK, NKE, NKG, NKGE pumps by exploring the following QR codes/links:

Video	QR code
How to dismantle and assemble Grundfos NK, NKE, NKG, NKGE single-stage pump	

7. Fault finding the product

DANGER Electric shock



Death or serious personal injury

- Before removing the terminal box cover and before removing or dismantling the pump, make sure that the power supply has been switched off and that it cannot be accidentally switched on again.

WARNING Escaping liquid

Death or serious personal injury



- Pay attention to the orientation of the vent hole to ensure that the escaping liquid does not cause personal injury or damage to the motor or other components.
- In hot-liquid installations, pay special attention to the risk of personal injury caused by scalding hot liquid.
- In cold-liquid installations, pay special attention to the risk of personal injury caused by cold liquid.

CAUTION Hot surface



Minor or moderate personal injury

- When pumping hot liquids, make sure that no one can accidentally come into contact with hot surfaces.

CAUTION Cold surface



Minor or moderate personal injury

- When pumping cold liquids, make sure that no one can accidentally come into contact with cold surfaces.

Fault	Cause	Remedy
1. The pump delivers no or too little liquid.	a) The electrical connection is wrong, for instance two phases.	<ol style="list-style-type: none"> 1. Check the electrical connection. 2. Remedy, if necessary.
	b) The direction of rotation is wrong.	<ul style="list-style-type: none"> • Interchange two phases of the power supply.
	c) There is air in inlet pipe.	<ul style="list-style-type: none"> • Vent the inlet pipe or the pump.
	d) The counterpressure is too high.	<ol style="list-style-type: none"> 1. Set the duty point according to the flow and head that the pump is selected for. 2. Check the system for debris. 3. Clean the system, if necessary.
	e) The inlet pressure is too low.	<ul style="list-style-type: none"> • Increase the liquid level on the inlet side. • Open the isolating valve in the inlet pipe. • Make sure that all the conditions in section Pipes and connections are complied with.
	f) The inlet pipe or impeller is blocked by debris.	<ul style="list-style-type: none"> • Clean the inlet pipe or pump.
	g) The pump draws in air due to a defective seal.	<ol style="list-style-type: none"> 1. Check the pipeline seals, pump housing gaskets and shaft seals. 2. Replace gaskets and seals, if necessary.
	h) The pump draws in air due to low liquid level.	<ol style="list-style-type: none"> 1. Increase the liquid level on the inlet side. 2. Keep the liquid level as constant as possible.
2. The motor-protective circuit breaker has tripped because the motor is overloaded.	a) The pump is blocked by debris.	<ul style="list-style-type: none"> • Clean the pump.
	b) The pump is running above rated duty point.	<ul style="list-style-type: none"> • Set the duty point according to the flow and head that the pump is selected for.
	c) The density or viscosity of the liquid is higher than specified upon order.	<ul style="list-style-type: none"> • If less flow is sufficient, reduce the flow on the outlet side. • If less flow is insufficient, fit a more powerful motor.
	d) The motor-protective circuit breaker overload setting is incorrect.	<ol style="list-style-type: none"> 1. Check the setting of the motor-protective circuit breaker. 2. Adjust the setting if necessary.
	e) The motor runs on two phases.	<ol style="list-style-type: none"> 1. Check the electrical connection. 2. Replace the fuse, if defective.
	f) The motor may be faulty	<ol style="list-style-type: none"> 1. Check the motor. 2. Replace the motor if necessary.

Fault	Cause	Remedy
3. The pump makes too much noise. The pump runs unevenly and vibrates.	a) The inlet pressure is too low, resulting in cavitation in the pump.	<ul style="list-style-type: none"> • Increase the liquid level on the inlet side. • Open the isolating valve in the inlet pipe. • Make sure that all the conditions in section Pipes are complied with.
	b) There is air in the inlet pipe or pump.	<ul style="list-style-type: none"> • Vent the inlet pipe or the pump.
	c) The counterpressure is lower than specified.	<ul style="list-style-type: none"> • Set the duty point according to the flow and head that the pump is selected for.
	d) The pump draws in air due to low liquid level.	<ul style="list-style-type: none"> • Increase the liquid level on the inlet side and keep it as constant as possible.
	e) The impeller is out of balance or the impeller blades are clogged.	<ol style="list-style-type: none"> 1. Clean the impeller. 2. Check the impeller blades, clean them if necessary.
	f) The split coupling is out of balance.	<ol style="list-style-type: none"> 1. Check coupling gap and that set screws in split coupling are tightened. 2. Disassemble split coupling to inspect keys and keyways and their alignment with coupling pieces.
	g) The inner parts are worn.	<ul style="list-style-type: none"> • Replace the defective parts.
	h) The pump is stressed by the pipes thus causing starting noise.	<ul style="list-style-type: none"> • Mount the pump so that it is not stressed. • Support the pipes.
	i) The bearings are defective.	<ul style="list-style-type: none"> • Replace the bearings.
	j) The motor fan is defective.	<ul style="list-style-type: none"> • Replace the fan.
	k) There are foreign bodies in the pump.	<ul style="list-style-type: none"> • Clean the pump.
4. The pump, connections or mechanical shaft seal is leaking.	l) Frequency converter operation causes noise.	<ul style="list-style-type: none"> • Find the different remedies in Frequency converter operation section. See section Frequency converter operation.
	a) The pump is stressed by the pipes which causes leaks in the pump housing or at connections.	<ul style="list-style-type: none"> • Mount the pump so that it is not stressed. • Support the pipes.
	b) Pump housing gaskets and gaskets at connections are defective.	<ul style="list-style-type: none"> • Replace the pump housing gaskets or gaskets at connections.
	c) The mechanical shaft seal is dirty or stuck together.	<ul style="list-style-type: none"> • Check and clean the mechanical shaft seal.
	d) The mechanical shaft seal is defective.	<ul style="list-style-type: none"> • Replace the mechanical shaft seal.
5. The temperature in the pump or motor is too high.	e) The shaft surface is defective.	<ul style="list-style-type: none"> • Replace the shaft.
	a) There is air in the inlet pipe or pump.	<ol style="list-style-type: none"> 1. Vent the inlet pipe or the pump. 2. Fill up the inlet pipe and the pump again.
	b) The inlet pressure is too low.	<ul style="list-style-type: none"> • Increase the liquid level on the inlet side. • Open the isolating valve in the inlet pipe. • Make sure that all the conditions in section Pipes are complied with.
	c) The bearings are lubricated with too little, too much or unsuitable lubricant.	<ul style="list-style-type: none"> • Replenish, reduce or replace the lubricant.
	d) The axial pressure is too high.	<ol style="list-style-type: none"> 1. Check the relief holes of the impeller on the inlet side. 2. Clean the holes, if necessary
	e) The motor-protective circuit breaker is defective or the setting is incorrect.	<ol style="list-style-type: none"> 1. Check the setting of the motor-protective circuit breaker. 2. Replace the circuit breaker if necessary.
6. Oil is leaking from the bearing bracket.	f) The motor is overloaded.	<ul style="list-style-type: none"> • Reduce the flow rate.
	a) The bearing bracket has been filled with too much oil through the filling hole, resulting in an oil level above the bottom of the shaft.	<p>Drain off oil until the constant-level oiler starts to operate, that is when air bubbles can be seen in the reservoir.</p>
7. Oil is leaking from the reservoir.	b) The oil seals are defective.	<p>Replace the oil seals.</p>
	The threads on the reservoir are damaged.	<p>Replace the reservoir.</p>

Tangential outlet, single seal, closed impeller

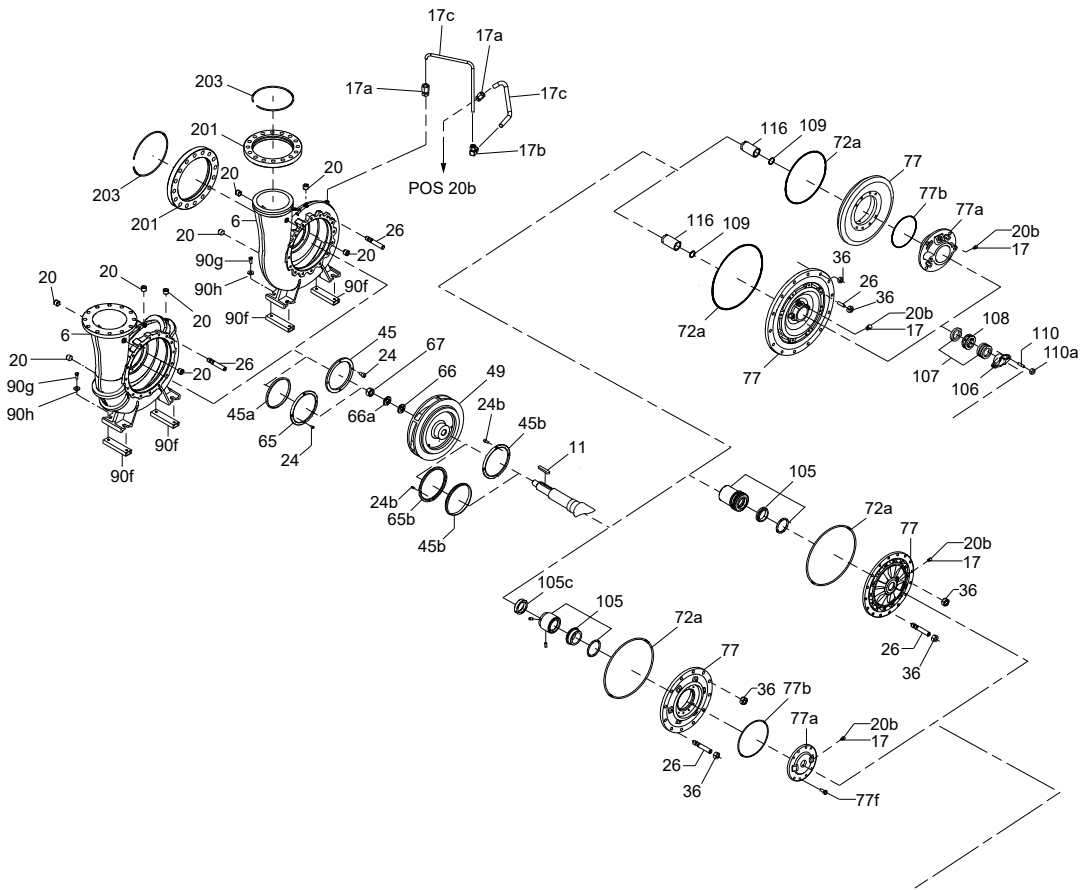

Bearing bracket

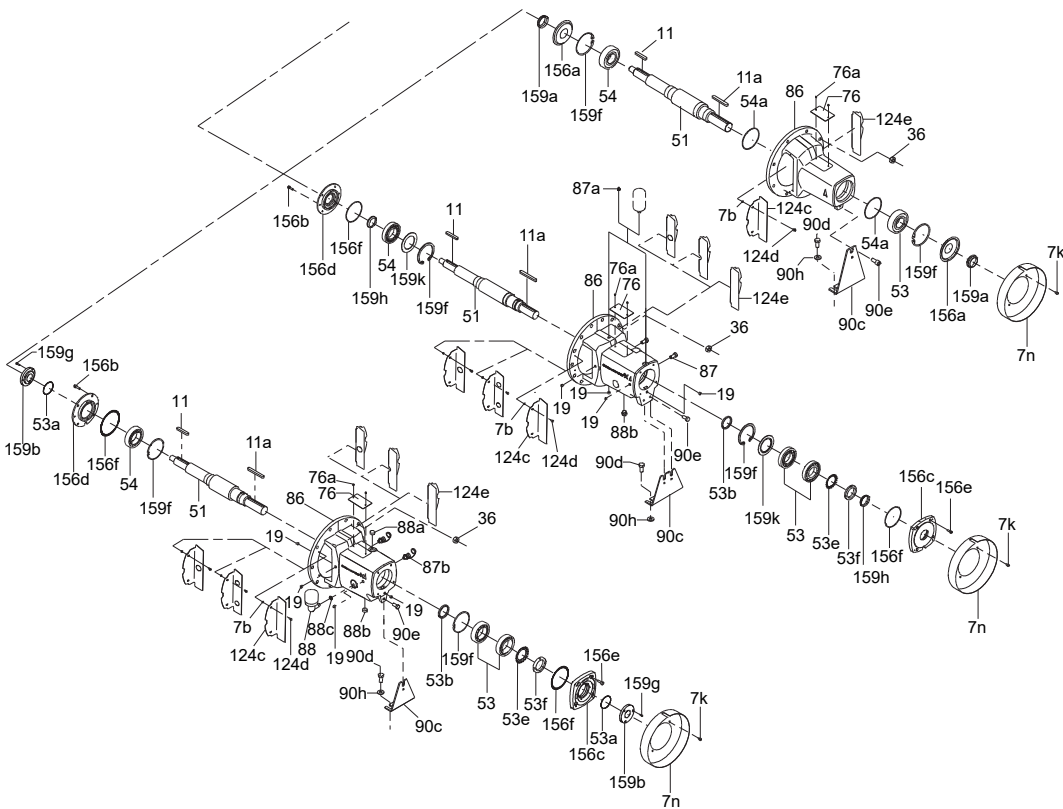

TM082148

TM082149

Coupling and base frame, Service range - R6

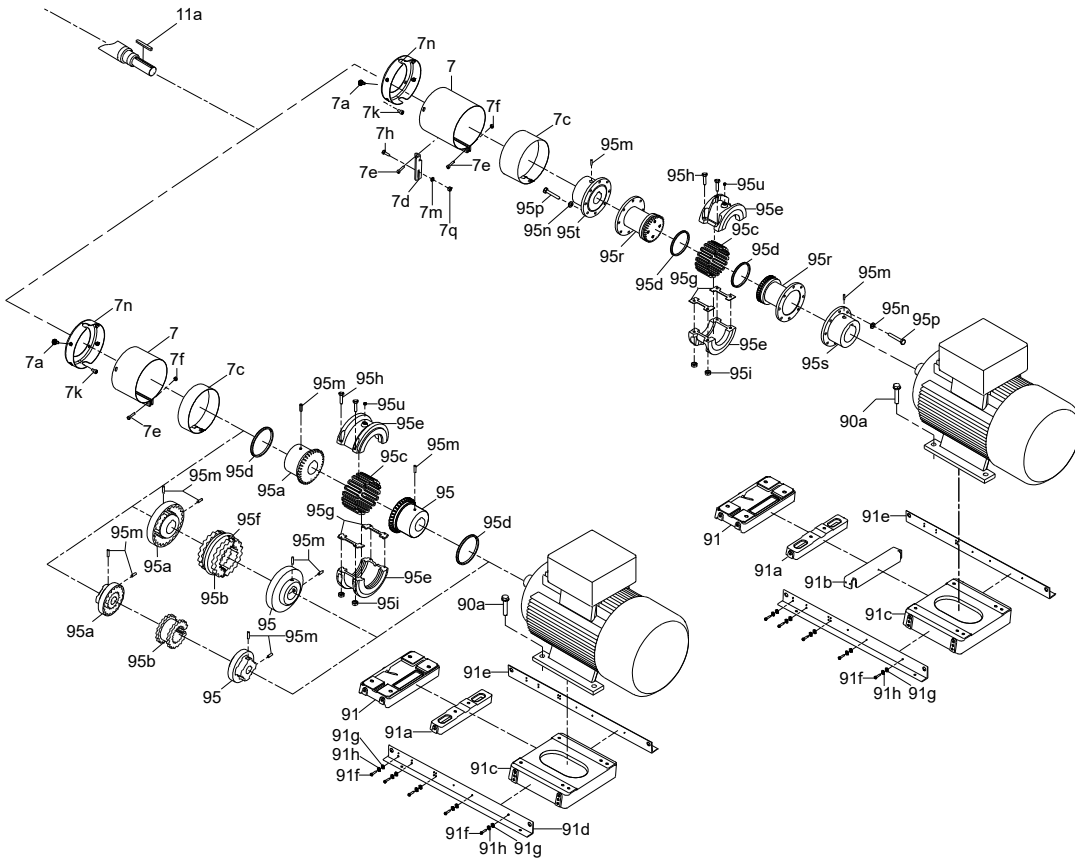

TM082105

Appendix A

A.1. Drawings for special tools

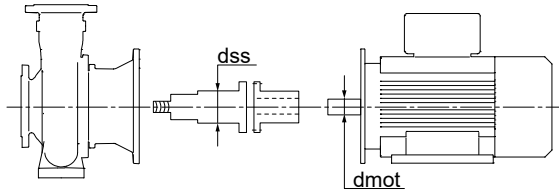

NB dss, dmot dimensions

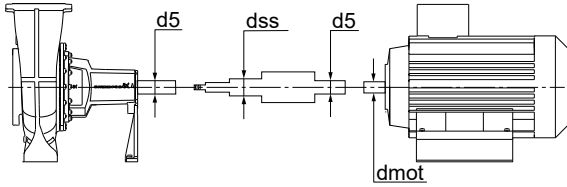

NK dss, d5, dmot dimensions

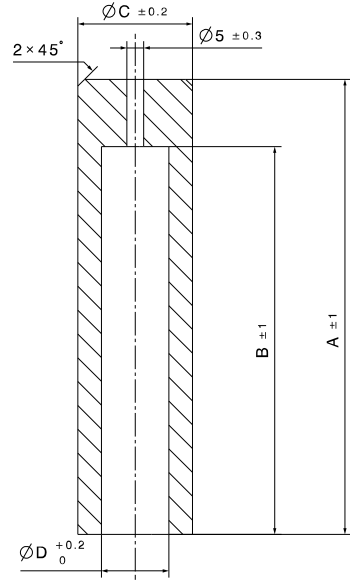

TM083952

Protective tool

This dimensional drawing can be used to manufacture needed protective tool. The tools can be manufactured in steel or nylon.

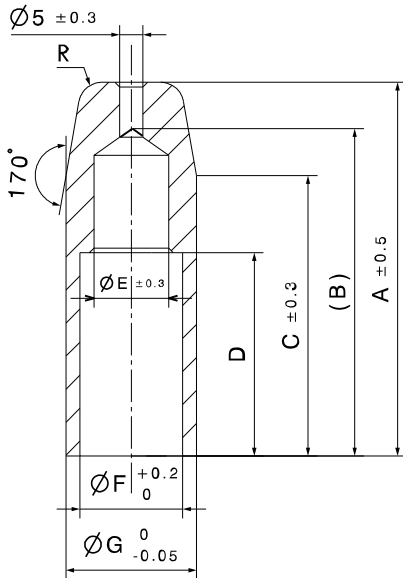

TM083954

Shaft seal diameter - dss [mm]	A	B	C	D	E	F	G	R
20	80	70	65	43.5	14	15	20	3
28	80	70	60	43.5	16	22	28	5
38	114	100	84	66	22	30	38	5
48	140	125	110	86	27	38	48	5
55	160	145	130	96.5	31	44	55	5
60	165	150	135	106	37	50	60	5

Punch for shaft seal

This dimensional drawing can be used to manufacture needed punch tool. The tools can be manufactured in steel or nylon.

Shaft seal diameter - dss [mm]	A	B	C	D
20	135	115	34	20
28	147	127	43	28
38	202	182	54	38
48	253.5	233.5	64	48
55	308.5	288.5	73	55
60	331.5	311.5	78	60
100	232	212	124	100

Positioning tool

This dimensional drawing can be used to manufacture needed positioning tool. The tools can be manufactured in steel or nylon.

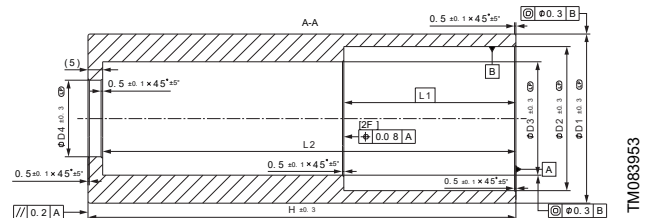
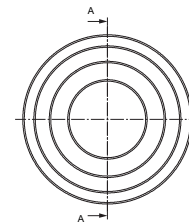

TM083953

Shaft seal	d5/dss	H	ØD1	ØD2	ØD3	ØD4	L1	L2	Weight [kg]
Single	D16/Ø20	44.5	24	-	15.5	13	-	39.5	0.094
Single	D24/Ø28	44.5	34	-	22.5	16	-	39.5	0.185
Single	D32/Ø38	67	44	-	30.5	20	-	62	0.429
Single	D42/Ø48	87	54	-	38.5	26	-	82	0.788
Single	D48/Ø55	97.5	61	-	44.5	29	-	92.5	1.074
Single	D60/Ø60	107	66	-	50.5	35	-	102	1.224
Single	D100/Ø100	153	110	-	85.5	18	-	148	0.683

Argentina

Bombas GRUNDFOS de Argentina S.A.
Ruta Panamericana km. 37.500 Industiun
1619 - Garin Pcia. de B.A.
Tel.: +54-3327 414 444
Fax: +54-3327 45 3190

Australia

GRUNDFOS Pumps Pty. Ltd.
P.O. Box 2040
Regency Park
South Australia 5942
Tel.: +61-8-8461-4611
Fax: +61-8-8340-0155

Austria

GRUNDFOS Pumpen Vertrieb Ges.m.b.H.
Grundfosstraße 2
A-5082 Grödig/Salzburg
Tel.: +43-6246-883-0
Fax: +43-6246-883-30

Belgium

N.V. GRUNDFOS Bellux S.A.
Boomsesteenweg 81-83
B-2630 Aartselaar
Tel.: +32-3-870 7300
Fax: +32-3-870 7301

Bosnia and Herzegovina

GRUNDFOS Sarajevo
Zmaja od Bosne 7-7A
BiH-71000 Sarajevo
Tel.: +387 33 592 480
Fax: +387 33 590 465
www.ba.grundfos.com
E-mail: grundfos@bih.net.ba

Brazil

BOMBAS GRUNDFOS DO BRASIL
Av. Humberto de Alencar Castelo Branco,
630
CEP 09850 - 300
São Bernardo do Campo - SP
Tel.: +55-11 4393 5533
Fax: +55-11 4343 5015

Bulgaria

Grundfos Bulgaria EOOD
Slatina District
Iztochna Tangenta street no. 100
BG - 1592 Sofia
Tel.: +359 2 49 22 200
Fax: +359 2 49 22 201
E-mail: bulgaria@grundfos.bg

Canada

GRUNDFOS Canada inc.
2941 Brighton Road
Oakville, Ontario
L6H 6C9
Tel.: +1-905 829 9533
Fax: +1-905 829 9512

China

GRUNDFOS Pumps (Shanghai) Co. Ltd.
10F The Hub, No. 33 Suhong Road
Minhang District
Shanghai 201106 PRC
Tel.: +86 21 612 252 22
Fax: +86 21 612 253 33

Colombia

GRUNDFOS Colombia S.A.S.
Km 1.5 vía Siberia-Cota Conj. Potrero
Chico,
Parque Empresarial Arcos de Cota Bod. 1A.
Cota, Cundinamarca
Tel.: +57(1)-2913444
Fax: +57(1)-8764586

Croatia

GRUNDFOS CROATIA d.o.o.
Buzinski prilaz 38, Buzin
HR-10010 Zagreb
Tel.: +385 1 6595 400
Fax: +385 1 6595 499
www.hr.grundfos.com

Czech Republic

GRUNDFOS Sales Czechia and Slovakia
s.r.o.
Čajkovského 21
779 00 Olomouc
Tel.: +420-585-716 111

Denmark

GRUNDFOS DK A/S
Martin Bachs Vej 3
DK-8850 Bjerringbro
Tel.: +45-87 50 50 50
Fax: +45-87 50 51 51
E-mail: info_GDK@grundfos.com
www.grundfos.com/DK

Estonia

GRUNDFOS Pumps Eesti OÜ
Peterburi tee 92G
11415 Tallinn
Tel.: + 372 606 1690
Fax: + 372 606 1691

Finland

OY GRUNDFOS Pumput AB
Trukkikuja 1
FI-01360 Vantaa
Tel.: +358-(0) 207 889 500

France

Pompes GRUNDFOS Distribution S.A.
Parc d'Activités de Chesnes
57, rue de Malacombe
F-38290 St. Quentin Fallavier (Lyon)
Tel.: +33-4 74 82 15 15
Fax: +33-4 74 94 10 51

Germany

GRUNDFOS GMBH
Schlüterstr. 33
40699 Erkrath
Tel.: +49-(0) 211 929 69-0
Fax: +49-(0) 211 929 69-3799
E-mail: infoservice@grundfos.de
Service in Deutschland:
kundendienst@grundfos.de

Greece

GRUNDFOS Hellas A.E.B.E.
20th km. Athinon-Markopoulou Av.
P.O. Box 71
GR-19002 Peania
Tel.: +0030-210-66 83 400
Fax: +0030-210-66 46 273

Hong Kong

GRUNDFOS Pumps (Hong Kong) Ltd.
Unit 1, Ground floor, Siu Wai industrial
Centre
29-33 Wing Hong Street & 68 King Lam
Street, Cheung Sha Wan
Kowloon
Tel.: +852-27861706 / 27861741
Fax: +852-27858664

Hungary

GRUNDFOS South East Europe Kft.
Tópark u. 8
H-2045 Törökbálint
Tel.: +36-23 511 110
Fax: +36-23 511 111

India

GRUNDFOS Pumps India Private Limited
118 Old Mahabalipuram Road
Thoraiakkam
Chennai 600 097
Tel.: +91-44 2496 6800

Indonesia

PT GRUNDFOS Pompa
Graha intrub Lt. 2 & 3
Jln. Cililitan Besar No.454. Makasar,
Jakarta Timur
ID-Jakarta 13650
Tel.: +62 21-469-51900
Fax: +62 21-460 6910 / 460 6901

Ireland

GRUNDFOS (Ireland) Ltd.
Unit A, Merrywell Business Park
Ballymount Road Lower
Dublin 12
Tel.: +353-1-4089 800
Fax: +353-1-4089 830

Italy

GRUNDFOS Pompe Italia S.r.l.
Via Gran Sasso 4
I-20060 Truccazzano (Milano)
Tel.: +39-02-95838112
Fax: +39-02-95309290 / 95838461

Japan

GRUNDFOS Pumps K.K.
1-2-3, Shin-Miyakoda, Kita-ku
Hamamatsu
431-2103 Japan
Tel.: +81 53 428 4760
Fax: +81 53 428 5005

Kazakhstan

Grundfos Kazakhstan LLP
7' Kyz-Zhibek Str., Kok-Tobe micr.
KZ-050020 Almaty Kazakhstan
Tel.: +7 (727) 227-98-55/56

Korea

GRUNDFOS Pumps Korea Ltd.
6th Floor, Aju Building 679-5
Yeoksam-dong, Kangnam-ku, 135-916
Seoul, Korea
Tel.: +82-2-5317 600
Fax: +82-2-5633 725

Latvia

SIA GRUNDFOS Pumps Latvia
Deglava biznesa centrs
Augusta Deglava ielā 60
LV-1035, Rīga,
Tel.: + 371 714 9640, 7 149 641
Fax: + 371 914 9646

Lithuania

GRUNDFOS Pumps UAB
Smolensko g. 6
LT-03201 Vilnius
Tel.: +370 52 395 430
Fax: +370 52 395 431

Malaysia

GRUNDFOS Pumps Sdn. Bhd.
7 Jalan Peguam U1/25
Glenmarie industrial Park
40150 Shah Alam, Selangor
Tel.: +60-3-5569 2922
Fax: +60-3-5569 2866

Mexico

Bombas GRUNDFOS de México
S.A. de C.V.
Boulevard TLC No. 15
Parque industrial Stiva Aeropuerto
Apodaca, N.L. 66600
Tel.: +52-81-8144 4000
Fax: +52-81-8144 4010

Netherlands

GRUNDFOS Netherlands
Veluwezoom 35
1326 AE Almere
Postbus 22015
1302 CA ALMERE
Tel.: +31-88-478 6336
Fax: +31-88-478 6332
E-mail: info_gnl@grundfos.com

New Zealand

GRUNDFOS Pumps NZ Ltd.
17 Beatrice Tinsley Crescent
North Harbour Industrial Estate
Albany, Auckland
Tel.: +64-9-415 3240
Fax: +64-9-415 3250

Norway

GRUNDFOS Pomper A/S
Stramsveien 344
Postboks 235, Leirdal
N-1011 Oslo
Tel.: +47-22 90 47 00
Fax: +47-22 32 21 50

Poland

GRUNDFOS Pompy Sp. z o.o.
ul. Klonowa 23
Baranowo k. Poznania
PL-62-081 Przeźmierowo
Tel.: (+48-61) 650 13 00
Fax: (+48-61) 650 13 50

Portugal

Bombas GRUNDFOS Portugal, S.A.
Rua Calvet de Magalhães, 241
Apartado 1079
P-2770-153 Paço de Arcos
Tel.: +351-21-440 76 00
Fax: +351-21-440 76 90

Romania

GRUNDFOS Pompe România SRL
S-PARK BUSINESS CENTER, Clădirea
A2, etaj 2
Str. Tipografilor, Nr. 11-15, Sector 1, Cod
013714
Bucuresti, Romania
Tel.: 004 021 2004 100
E-mail: romania@grundfos.ro

Serbia

Grundfos Srbija d.o.o.
Omladinskih brigada 90b
11070 Novi Beograd
Tel.: +381 11 2258 740
Fax: +381 11 2281 769
www.rs.grundfos.com

Singapore

GRUNDFOS (Singapore) Pte. Ltd.
25 Jalan Tukang
Singapore 619264
Tel.: +65-6681 9688
Fax: +65-6681 9689

Slovakia

GRUNDFOS s.r.o.
Prievozská 4D 821 09 BRATISLAVA
Tel.: +421 2 5020 1426
sk.grundfos.com

Slovenia

GRUNDFOS LJUBLJANA, d.o.o.
Leskoškova 9e, 1122 Ljubljana
Tel.: +386 (0) 1 568 06 10
Fax: +386 (0) 1 568 06 19
E-mail: tehnika-si@grundfos.com

South Africa

GRUNDFOS (PTY) LTD
16 Lascelles Drive, Meadowbrook Estate
1609 Germiston, Johannesburg
Tel.: (+27) 10 248 6000
Fax: (+27) 10 248 6002
E-mail: Igradidge@grundfos.com

Spain

Bombas GRUNDFOS España S.A.
Camino de la Fuenteçilla, s/n
E-28110 Algete (Madrid)
Tel.: +34-91-848 8800
Fax: +34-91-628 0465

Sweden

GRUNDFOS AB
Box 333 (Lunnagårdsgatan 6)
431 24 Mölndal
Tel.: +46 31 332 23 000
Fax: +46 31 331 94 60

Switzerland

GRUNDFOS Pumpen AG
Bruggacherstrasse 10
CH-8117 Fällanden/ZH
Tel.: +41-44-806 8111
Fax: +41-44-806 8115

Taiwan

GRUNDFOS Pumps (Taiwan) Ltd.
7 Floor, 219 Min-Chuan Road
Taichung, Taiwan, R.O.C.
Tel.: +886-4-2305 0868
Fax: +886-4-2305 0878

Thailand

GRUNDFOS (Thailand) Ltd.
92 Chaloein Phrakiat Rama 9 Road
Dokmai, Pravej, Bangkok 10250
Tel.: +66-2-725 8999
Fax: +66-2-725 8998

Turkey

GRUNDFOS POMPA San. ve Tic. Ltd. Sti.
Gebze Organize Sanayi Bölgesi
İhsan dede Caddesi
2. yol 200. Sokak No. 204
41490 Gebze/ Kocaeli
Tel.: +90 - 262-679 7979
Fax: +90 - 262-679 7905
E-mail: satis@grundfos.com

Ukraine

ТОВ "ГРУНДФОС УКРАЇНА"
Бізнес Центр Європа
Столичне шосе, 103
м. Київ, 03131, Україна
Tel.: (+38 044) 237 04 00
Fax: (+38 044) 237 04 01
E-mail: ukraine@grundfos.com

United Arab Emirates

GRUNDFOS Gulf Distribution
P.O. Box 16768
Jebel Ali Free Zone, Dubai
Tel.: +971 4 8815 166
Fax: +971 4 8815 136

United Kingdom

GRUNDFOS Pumps Ltd.
Grovebury Road
Leighton Buzzard/Beds. LU7 4TL
Tel.: +44-1525-850000
Fax: +44-1525-850011

U.S.A.

Global Headquarters for WU
856 Koomey Road
Brookshire, Texas 77423 USA
Phone: +1-630-236-5500

Uzbekistan

Grundfos Tashkent, Uzbekistan
The Representative Office of Grundfos
Kazakhstan in Uzbekistan
38a, Oybek street, Tashkent
Tel.: (+998) 71 150 3290 / 71 150 3291
Fax: (+998) 71 150 3292

92888948 09.2025
ECM: 1431329