

Table of Contents:

1. Product Description	2
2. General	2
3. Pre-Installation Checks	2
4. Equipment required for Installation	2
5. General Installation Notes	3
5.1 Determination of Pipe Arrangement	3
5.2 Vertical Pipe Arrangement	3
5.3 Horizontal Pipe Arrangement	3
5.4 Misalignment	4
5.5 Required undisturbed Pipe Run Lengths	5
6. Installation of the ITABAR Sensor	6
6.1 Installation of Type FTM-20, FTM-25 and FTM-35	6
6.2 Installation of Type FTM-26 and FTM-36	7
6.3 Insertion Procedure for FTM	8
6.4 Retract Procedure for FTM	8
6.5 Installation of type FTMK	9
7. Installation of the Attachments and the Δp -Transmitter	9
7.1 Attachments	9
7.2 Δp -Transmitter	9
8. Measurement Start-Up	9
9. Preventive Maintenance of the ITABAR Sensors	10
10. Trouble Shooting	10

INTRA-AUTOMATION GmbH
Meß- und Regelinstrumente
Otto- Hahn- Straße 20
D-41515 Grevenbroich / GERMANY

Tel.: (+49) 21 81/75665-0
Fax.: (+49) 21 81/64492
E-MAIL: Intra-Automation @ T-Online.de

BA-E-045/Rev.2/25.04.00

1. Product Description

We congratulate you on your purchase of an ITABAR Flo-Tap Sensor of the type FTM.

When installed properly, the ITABAR Sensor offers an array of advantages over other measurement systems with respect to its accuracy, pressure loss and installation. The following guide is designed to help you with the sensor installation and operation.

2. General

FTM Flo-Tap Sensors are designed for installation under pressure in lines with static pressure up to 6 bar at 110°C for PTFE packing (to 400°C with graphite packing gland).

All items for installation are provided with Flo-Taps except for drilling and welding equipment.

These instructions call for the use of a Mueller DH-5 drilling machine (or equivalent), which is rated for 80 bar at 35°C with a maximum temperature of 120°C. This machine will handle the installation under pressure of the Flo-Tap Sensor FTM-25 under its full rated pressure of 70 bar. Other drilling machines are available.

The sensor material and the mounting hardware can be specially selected to accommodate special operating conditions (e.g. corrosive media).

3. Pre-Installation Checks

Before installation, make sure that all of the following parts are included in the sensor kit.

- ITABAR Sensor, type FTM
- Weld socket
- Sensor end support, closed or with sealing plug (for FTM-26 only)
- Instrument valve assembly (if ordered)

Compare the specifications on the type identification plate on the sensor with your order form.

The identification plate contains the following information:

- Serial number
- Type name
- Pipe inside diameter
- TAG number (Measuring location number - if furnished)
- Material

Attention!

Make sure that the pipe inside diameter given on the identification plate matches your pipe diameter.

4. Equipment required for installation

1. Welding equipment
2. Pressure (hot-tap) drilling machine; Mueller type DH-5 or equivalent.
3. 1 1/16" drill bit Mueller 33530
4. Drill holder Mueller 33555
5. Adapter nipple Mueller 36195

(Items 2 through 6 are available from Mueller Co., Decatur, Illinois. In most cases, the public service company in your city is available to do the "hot-tapping" job, or the equipment may be rented or purchased locally.)

Pressure drill machine and tooling:

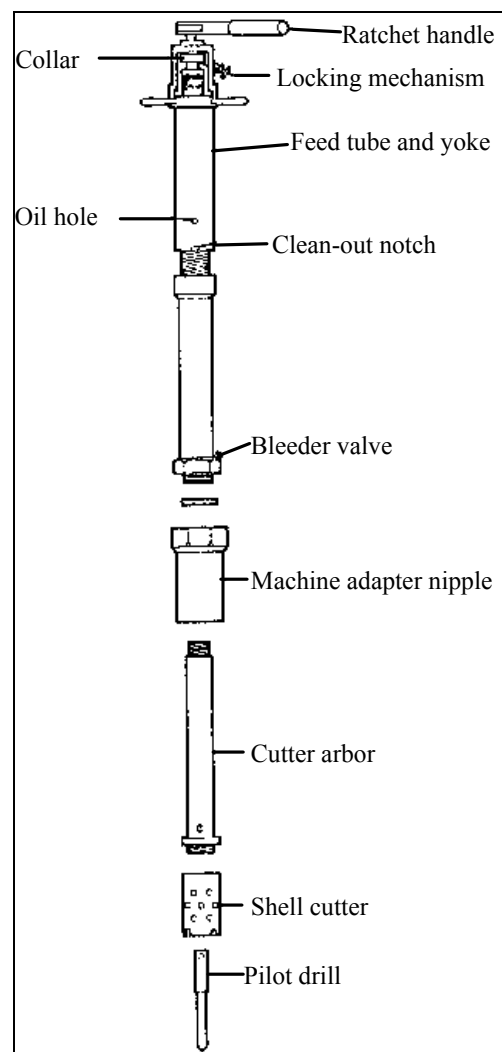

5. General Installation Notes

In order to obtain optimal measurement results, follow the notes concerning the installation of the ITABAR Sensor given below.

5.1 Determination of Pipe Arrangement

For design reasons, the pipe arrangement at the installation location has to be known before the sensor is manufactured.

For horizontal pipe arrangements the instrument connections are placed in-line with the flow direction (see Figure 2).

For vertical pipe arrangements, the instrument connections for the measurement of the differential pressure are arranged at an angle of 90° to the flow direction (see Figure 3).

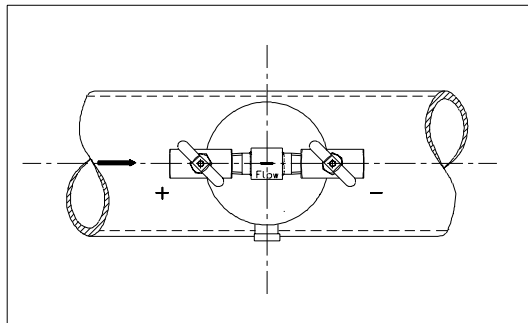

Fig. 2: Placement of the differential pressure connecting studs for horizontal pipe arrangement

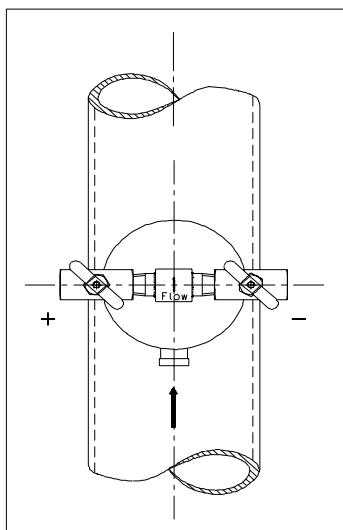

Fig. 3: Placement of the differential pressure connecting studs for vertical pipe arrangement

5.2 Vertical Pipe Arrangement

The ITABAR Sensor for flow measurement of liquids and gases can be installed in vertical pipe runs at any location, however, the instrument connections have to be located in the same horizontal plain (see Figure 4).

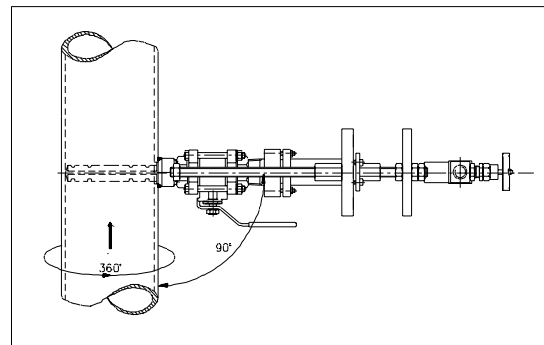

Fig. 4: Installation in vertical pipe runs for liquids or gases

5.3 Horizontal Pipe Arrangement

Liquids:

For flow measurements of liquids, the ITABAR Sensor must be installed in the lower half of the pipe circumference; the connections to the instruments have to be located below the pipe axis. This way, gas or air bubbles which may have found their way into the connections or the instruments will return into the flowing liquid.

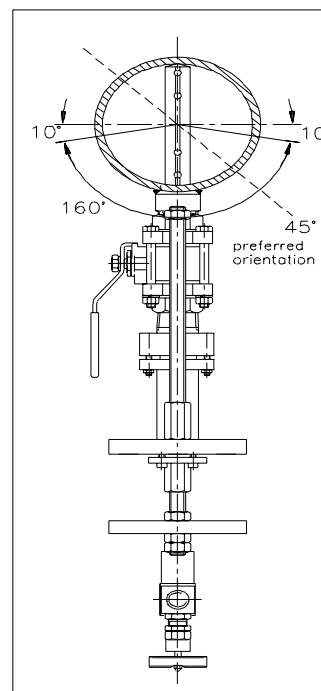

Fig. 5: Installation in horizontal pipe runs for liquids

The flow direction is indicated in each case by an arrow on the sensor head.

Fig. 7

Gases:

For the flow measurement of gases, the ITABAR Sensor must be installed in the upper portion of the pipe diameter. This will prevent moisture or condensation from entering the instrument connections and altering the measurements.

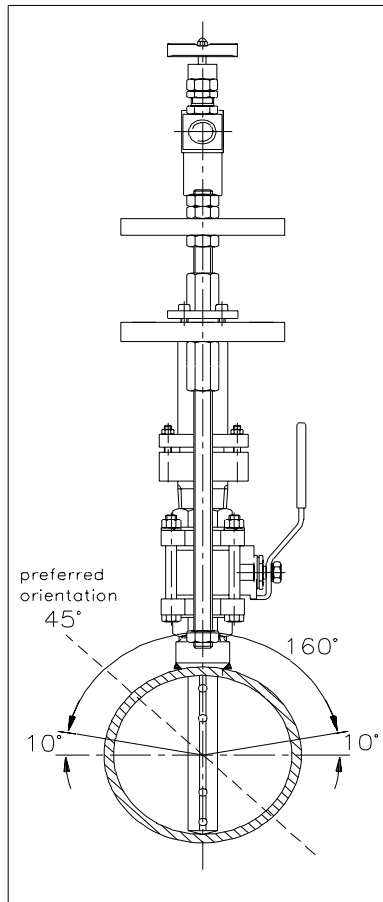

Fig. 6: Installation in horizontal pipe runs for gases

5.4 Misalignment

The ITABAR Sensor operates on the basis of simple physical principles.

The sensor is not affected by being slightly out of alignment.

The influence on the accuracy of the measurements is negligible as long as the limits indicated in Figures 7, 8 and 9 are not exceeded.

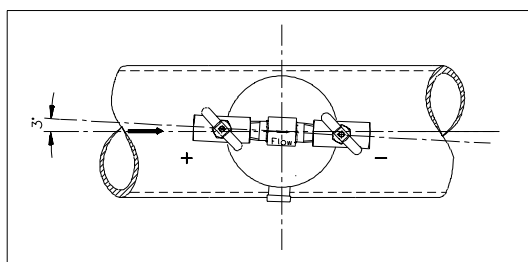

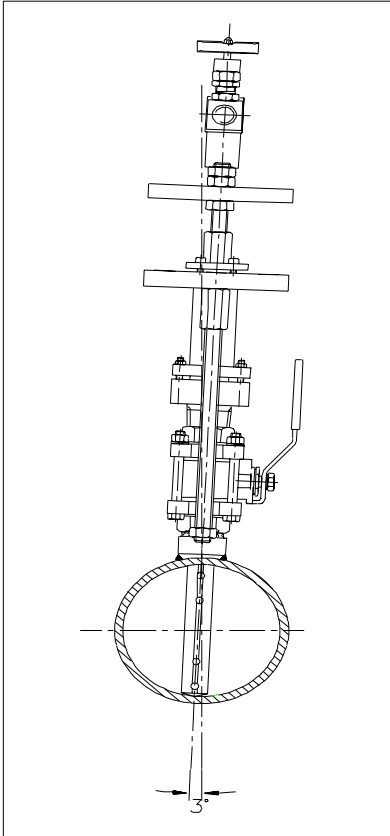

Fig. 8

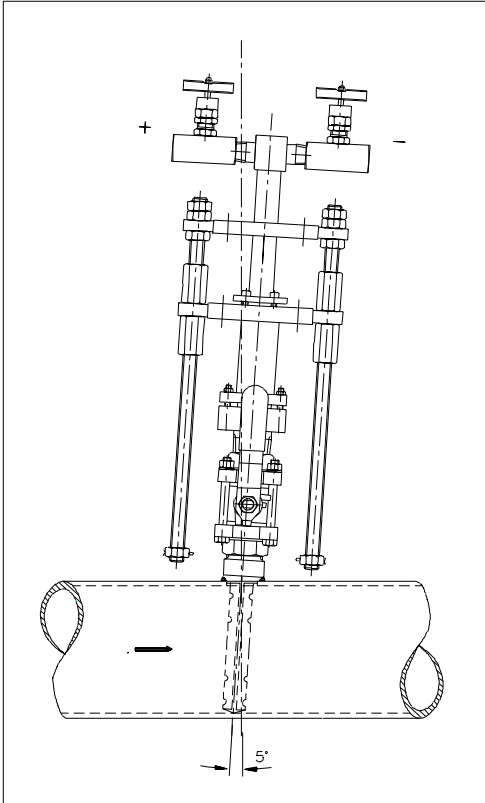

Fig. 9

5.5 Required Undisturbed Pipe Run Lengths in multiples of D)

The accuracy of the measurements of the ITABAR Sensor depends on the development of a stream profile which should be as undisturbed as possible. Therefore the selection of the installation location within the pipe run is of considerable importance. The following tried and true hints regarding the required pipe lengths ahead of and behind the sensor are designed to help you in your selection of the most advantageous installation location. As a general rule, regulating valves, throttle valves, and gate-type valves should be installed behind the sensor.

Note:

If the recommended straight pipe run lengths are not available, the measuring accuracy can be adjusted to the specific conditions of the measuring stretch by conducting a comparison measurement (e.g. Pitot tube, point measurement). The point measurement guarantees that the differential pressure corresponds to the true flow velocity, thereby assuring the specified accuracy. Details can be requested from the manufacturer.

D = Pipe Diameter	A=Upstream	B=Downstream
	7	3
	9	3
	17	4
	18	4
Restriction in the Pipe Run 	7	3
Widening of the Pipe Run 	7	3
Regulation Device 	24	4

6. Installation of the ITABAR Sensor

Observe the general installation notes!

6.1 Installation of Type FTM-20, FTM-25 and FTM-35

1. Verify that the line pressure is with rated limits of the drilling equipment to be used.
2. Grind off paint or other coatings from the pipe in the area where the Flo-Tap is to be installed.
3. Tack the mounting stud {1} (supplied with the Flo-Tap) onto the pipe leaving a clearance of 1-2 mm (Fig. 10).
4. Check the alignment of the mounting stud again. Then the finish weld can be made.
5. Fasten unit isolating valve {2} to the mounting stud {1} and open valve. Verify that the stem is in position as shown at figure 10 to insure clearance for the insert-retract rods.

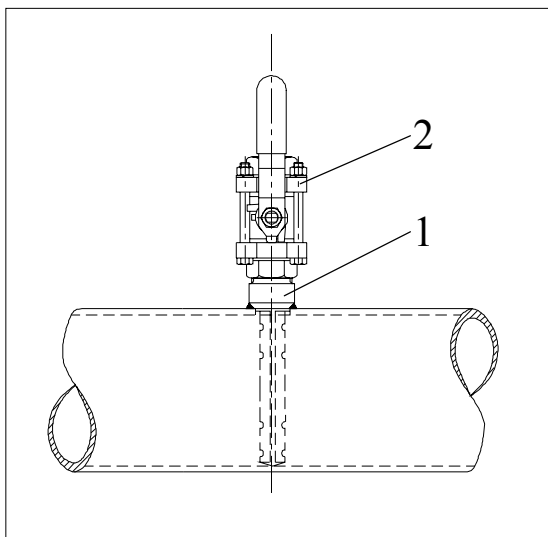
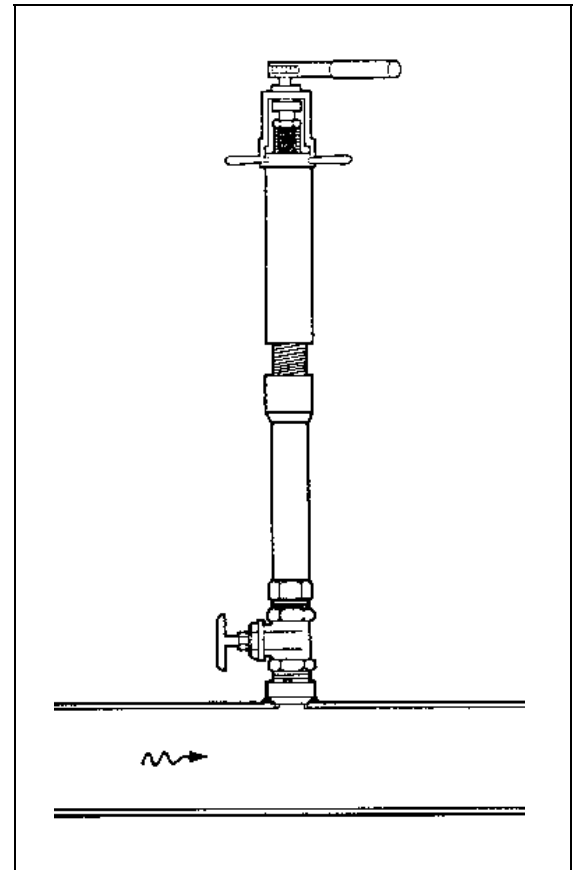

Fig. 10: Mounting stud with isolating valve

6. Fasten special adapter flanged nipple to unit isolating valve (Fig. 11).
7. Install cutter arbor, shell cutter and pilot drill to pressure drilling machine and attach the machine to its special flanged nipple.
8. Drill through the pipe wall in accordance with the instructions supplied with the drilling machine. For type FTM-20 \varnothing 21mm, FTM-25 \varnothing 35mm and FTM-35 \varnothing 40mm.
9. Withdraw the drill past the Flo-Tap unit isolating valve. Close the unit valve and remove drilling machine and special flanged nipple. Check for leakage at valve and connections.



10. Verify that the sensor profile {4} is fully retracted in the protection pipe {3}. Check the position of the threaded rod (Fig. 12)

Fig. 11 drilling machine with flanged adapter nipple mounted on unit isolating valve

11. Now seal the threaded stud {5} with a suitable sealing compound (Fig. 12).
12. Install the threaded stud {5} on the isolating valve {2} (Fig. 10 and 12).
13. Verify that the instrument valves are fully closed.
14. Check all connections for leakage by cracking open the unit isolating valve. If the unit was ordered with the optional high-temperature packing gland, additional adjustment may be required at this time. If necessary, screw down the 4 screws {6} of the top packing gland and the 4 screw nuts {7} of the bottom packing gland.
15. Increase line pressure to normal limits and check for leakage. If there is no apparent leakage, proceed to Flo-Tap Insertion 6.3. .

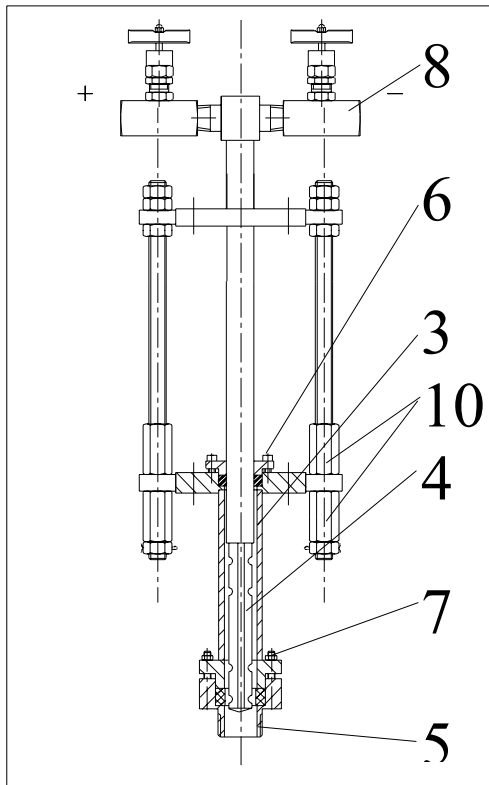

Fig. 12 Sensor profile with protection pipe

6.2 Installation of Type FTM-26 and FTM-36

The design of the ITABAR Sensor of the type FTM-26/36 is almost identical to the type FTM-25/35. The only difference is the sensor end support (with sealing plug or closed design (see Figs. 13a and 13b) which permits higher stream velocities in the pipe.

Attention!

Due to construction of the FTM-26/36 with end support it would cause many problems to install it for the first time during operation.

We recommend you to install this type during operation stop as per following instructions.

After installation also this sensor can be rejected and inserted as type FTM-25/35 under pressure.

Installation of weld socket:

1. Drill a hole of $\varnothing 35\text{mm}$ for type FTM-26 or $\varnothing 40\text{mm}$ for type FTM-36 diameter into the pipe.
2. Tack the weld socket {1} onto the pipe leaving approx. 2 mm clearance. Align the socket (e.g. with a bolt or pin) so that it is exactly perpendicular to the pipe axis (Fig. 13a/b).
3. Before final welding and installing the sensor, you have to mount the end support {5}.

Installation of the end support:

4. Take a cord and tie one end around the installed weld socket {4}. Wrap the other end of the cord around the pipe so that it forms a loop around the pipe. Mark the half-way point of the pipe circumference on the pipe.
5. Now drill a second hole of $\varnothing 35\text{ mm}$ for type FTM-26 or $\varnothing 40\text{mm}$ for type FTM-36 diameter into the pipe.
6. Remove the sealing plug (if present) from the sensor end support. Tack the sensor end support onto the pipe leaving approximately 2 mm clearance.
7. Insert the sensor into the pipe and check the alignment of the sensor end support. If necessary, correct the alignment.

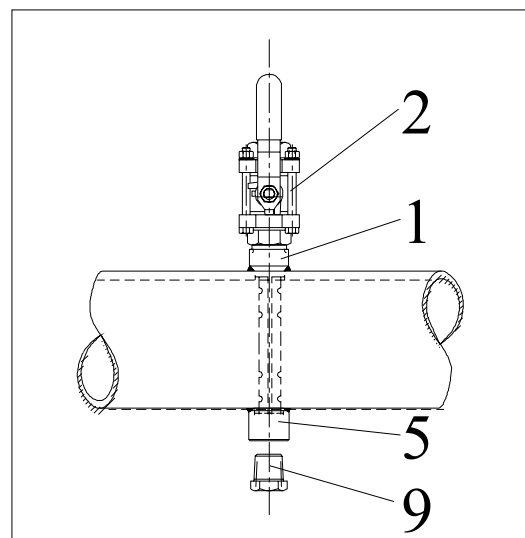

Fig. 13a: Installation hardware and sensor end support

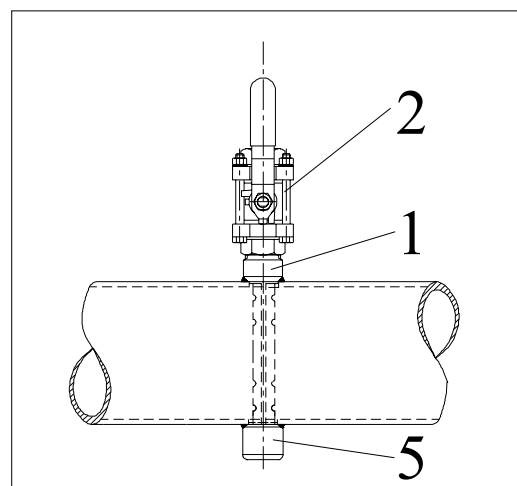

Fig. 13b: Installation hardware with sensor end support in closed design

8. Now the final welding can be carried out. Check the alignment of the weld socket again! For permissible deviations, see chapter 5.4. .
9. For sensor end supports with sealing plug only: Seal the thread of the sealing plug {9} with a suitable sealing compound (e.g. PTFE tape). Screw the sealing plug into the sensor end support and tighten it firmly (Fig. 13a).
10. Install the Flo-Tap unit isolating valve {2} on the welding socket. Verify that the valve is in fully open position, and that the stem is in line with the pipe to insure clearance for the insert-retract rods.
11. Perform the installation of the sensor into the pipe according to the instructions given in chapter 6.1. steps 10 through 15.

6.3 Insertion Procedure for FTM

1. Verify that the Flo-Tap insert-retract mechanism are in the position as shown in Fig. 14.
2. Verify that the Flo-Tap instrument valves {8} are fully closed and that the unit isolating valve {2} is fully open (Fig. 13 and 14).
3. Initiate probe insertion by rotating the drive nuts {10} clockwise as viewed from the top, using ratchet wrench. The nuts must be tightened alternately, about two turns at a time to prevent binding resulting from unequal loading.

Continue this procedure until probe contacts the opposite side of the pipe or end support (FTM-26)

4. Inspect the packing gland for evidence of leakage. If the unit was ordered with high-temperature gland, additional adjustment may be required at this time.
5. Connect instrument lines to the instrument valves and to the appropriate meter, recorder, transmitter or controller.
6. Open the Flo-Tap instrument valves {8}. Then purge or bleed the connecting lines and readout equipment as required.

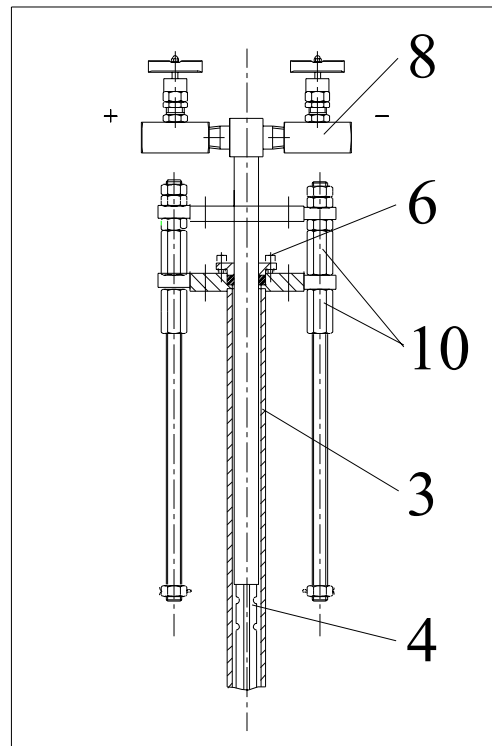

Fig. 14

6.4 Retract Procedure for FTM

1. Fully close the Flo-Tap instrument valves {8}. Then, if required, depressurize and disconnect the instrument lines.
2. Loosen slightly packing gland {6+7} before proceeding with retraction.
3. Retract the Flo-Tap by rotating the drive nuts {10} clockwise as viewed from the top, using ratched wrench. The nuts must be turned alternately, about two turns a time, to prevent binding resulting from unequal loading.

Continue this procedure until the probe is fully retracted as shown in Fig. 15.

4. After the probe is fully retracted, the Flo-Tap unit isolating valve {2} may closed for complete disassembly.

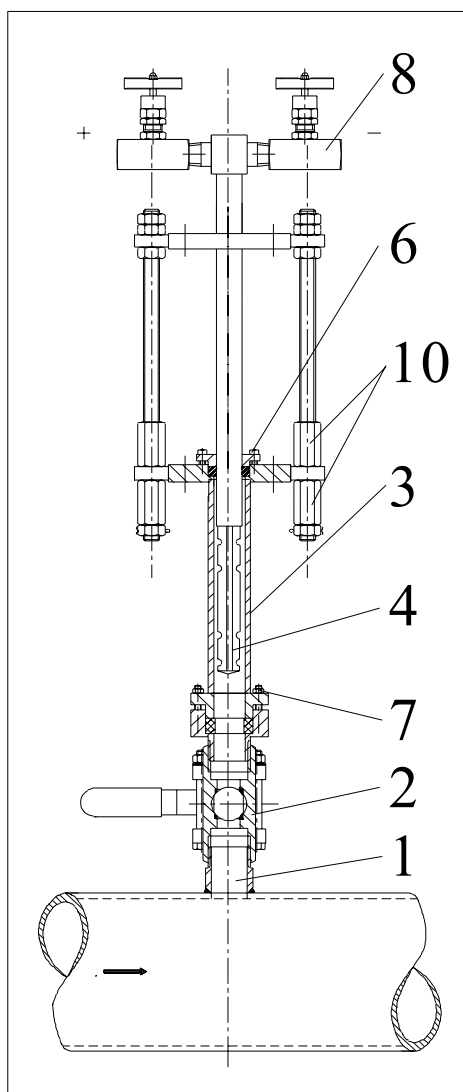

Fig. 15 retracted Flo-Tap Sensor

6.5 Installation of type FTMK

The difference between type FTM and FTMK is the gear drive mechanism instead of the threaded rod system. So you don't must move the nuts, only you must drive the hand wheel of the gear drive system. For installation, use chapter 6.1 to 6.4.

7. Installation of the Attachments and the Δp -Transmitter

7.1 Attachments

The instrument valves for the differential pressure lines are pre-installed by the manufacturer, if they are part of the order. When installing multi-directional valve blocks, make sure that all bolts are tightened uniformly and opposite bolts are tightened in sequence.

7.2 Δp -Transmitter

For liquid measurements, the differential pressure transmitter should always be installed below the ITABAR Sensor in order to avoid the occurrence of air bubbles in the instrument connections (Fig. 16)

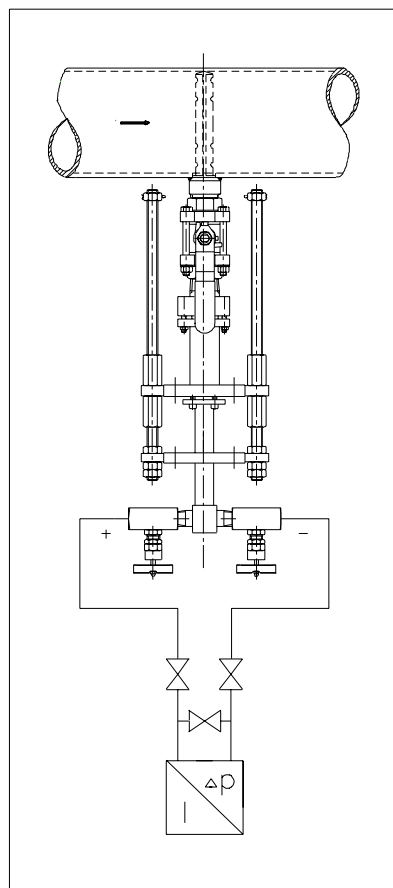

Fig. 16: Arrangement of sensor and differential pressure transmitter for measurement of liquid flows

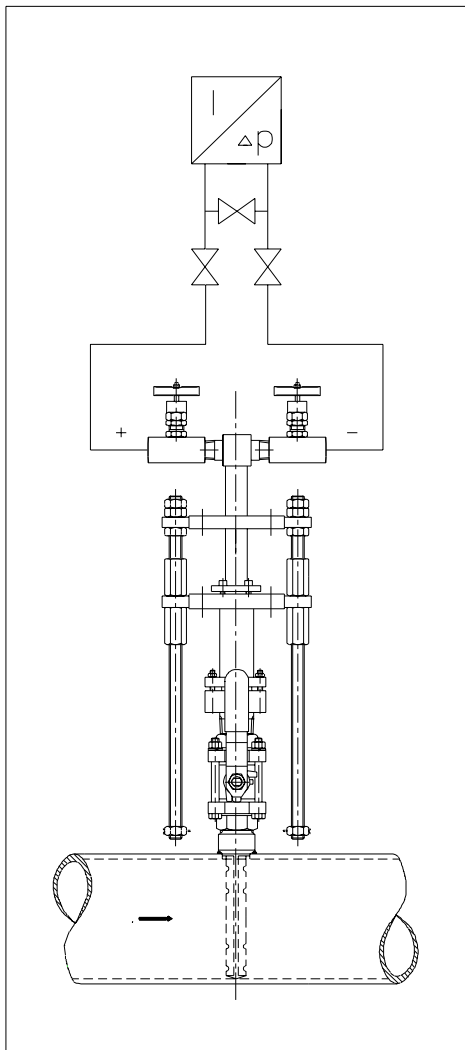

Fig. 17: Arrangement of sensor and Δp -Transmitter for gas flow measurements

When measuring dry gases and air, the differential pressure transmitter should always be installed above the ITABAR Sensor in order to avoid measurement degradation due to condensation and the presence of solid particles (Fig. 17).

8. Measurement Start-Up

Make sure that:

- all installation openings are closed (sensor end support FTM-26/36),
- all installed parts are securely bolted together,
- all instrument valves are closed.

Now the pipe can be cleared for the appropriate medium.

Check all connections for tightness, especially the threaded connection around the cutting ring.

Then open the instrument valves to the Δp -transmitter.

Note:

When measuring liquids, the differential pressure lines and the transmitter absolutely must be vented. Open the venting screws on the back side of the transmitter and keep them open until all air has escaped from the transmitter and the connecting lines.

9. Maintenance of the ITABAR Sensor

ITABAR Sensors are insensitive to dirt and soil build-up and therefore nearly maintenance-free.

10. Trouble Shooting

If, after the start-up of the ITABAR Sensor, any measuring errors occur, they may possibly be corrected quite easily:

Error:

No differential pressure indication

Correction:

Check whether all instrument valves to the Δp -transmitter are opened.

Check the alignment of the sensor with the pipe. The arrow on the sensor must point exactly in the flow direction.

Error:

Sensor end support leaks (FTM-26/36 only)

Correction:

Check whether the threads of the sensor end support have been sealed. Check whether the sealing compound is suited for the flow medium.

Note:

With highly corrosive media it is possible (if the sensor material has not been specifically selected for such operating conditions) that a connection between the plus and minus sides has been formed. This can only be checked after removal of the sensor from the pipe. Close the holes in the sensor rod and blow through both minus and plus connections of the sensor (e.g. with compressed air). If air emerges from the opposite connection, the sensor is defective. In this case, please notify the manufacturer.