



KIESELMANN
FLUID PROCESS GROUP

Translation of the original

Operating instruction

Butterfly valve



KIESELMANN GmbH

Paul-Kieselmann-Str. 4-10
75438 Knittlingen

 +49(0) 7043 371-0 •  +49(0) 7043 371-125
www.kieselmann.de • info@kieselmann.de

Copyright: © KIESELMANN FLUID PROCESS GROUP

Table of contents

1	General informations	4
1.1	Informations for your safety	4
1.2	Marking of security instructions	4
1.3	General designated use	4
1.4	Personnel	4
1.5	Modifications, spare parts, accessories	5
1.6	General instructions	5
2	Safety instructions	6
2.1	Intended use	6
2.2	General notes	6
2.3	General safety instructions	6
3	Delivery, transport and storage	7
3.1	Delivery	7
3.2	Transport	7
3.3	Storage	7
4	Specification	8
4.1	Modular system	8
4.2	Valve types	9
5	Function and operation	10
5.1	Description of function	10
5.2	Dry running	10
5.3	Control system and position indication	10
5.4	Pneumatic valve activation	12
6	Commissioning, service and maintenance	13
6.1	Commissioning	13
6.1.1	Installation instructions	13
6.1.2	General welding guidelines	13
6.1.3	ATEX - Guidelines	13
6.2	Service	13
6.3	Cleaning	14
7	Technical data	15
7.1	Butterfly valve / Intermediate flanged - butterfly valve	15
7.2	Leakage - butterfly valves	16
8	Disassembly and assembly	17
8.1	Disassembly	17
8.2	Assembly	19
9	Drawings and dimensions	20
9.1	Butterfly valve	20
9.2	Intermediate flange-butterfly valves	22
9.3	Leakage butterfly valve	25
9.4	drive systems	28
9.5	Control units	30
10	Wearing parts	31
10.1	Butterfly valve	31
10.2	Leakage - butterfly valves	31
10.3	Intermediate - butterfly valve	32
11	Malfunctions	33
12	Classification	34
12.1	Structure of order number	34
13	Appendix	36
13.1	Declaration of incorporation	36

1 General informations

1.1 Informations for your safety

We are pleased that you have decided for a high-class KIESELMANN GmbH product. With correct application and adequate maintenance, our products provide long time and reliable operation.





Before installation and initiation, please carefully read this instruction manual and the security advices contained in it. This guarantees reliable and safe operation of this product and your plant respectively. Please note that an incorrect application of the process components may lead to great material damages and personal injury.

In case of damages caused by non observance of this instruction manual, incorrect initiation, handling or external interference, guarantee and warranty will lapse!

Our products are produced, mounted and tested with high diligence. However, if there is still a reason for complaint, we will naturally try to give you entire satisfaction within the scope of our warranty. We will be at your disposal also after expiration of the warranty. In addition, you will also find all necessary instructions and spare part data for maintenance in this instruction manual. If you don't want to carry out the maintenance by yourself, our KIESELMANN GmbH - service team will naturally be at your disposal.

1.2 Marking of security instructions

Hints are available in the chapter "safety instructions" or directly before the respective operation instruction. The hints are highlighted with a danger symbol and a signal word. Texts beside these symbols have to be read and adhered to by all means. Please continue with the text and with the handling at the valve only afterwards.

Symbol	Signal word	Meaning
	DANGER	Imminent danger which will result severe personal injury or death.
	WARNING	Imminent danger which may result severe personal injury or death.
	CAUTION	Dangerous situation which may cause slight personal injury or material damages.
	NOTICE	An harmful situation which may result in damages of the product itself or of adjacent vicinity.
	INFORMATION	Marks application hints and other information which is particularly useful.

1.3 General designated use

The fitting is designed exclusively for the purposes described below. Using the fitting for purposes other than those mentioned is considered contrary to its designated use. KIESELMANN GmbH cannot be held liable for any damage resulting from such use. The risk of such misuse lies entirely with the user. The prerequisite for the reliable and safe operation of the fitting is proper transportation and storage as well as competent installation and assembly. Operating the fitting within the limits of its designated use also involves observing the operating, inspection and maintenance instructions.

1.4 Personnel

Personnel entrusted with the operation and maintenance of the tank safety system must have the suitable qualification to carry out their tasks. They must be informed about possible dangers and must understand and observe the safety instructions given in the relevant manual. Only allow qualified personnel to make electrical connections.

1.5 Modifications, spare parts, accessories

Unauthorized modifications, additions or conversions which affect the safety of the fitting are not permitted. Safety devices must not be bypassed, removed or made inactive. Only use original spare parts and accessories recommended by the manufacturer.

1.6 General instructions

The user is obliged to operate the fitting only when it is in good working order. In addition to the instructions given in the operating manual, please observe the relevant accident prevention regulations, generally accepted safety regulations, regulations effective in the country of installation, working and safety instructions effective in the user's plant.

2 Safety instructions

2.1 Intended use

The butterfly valve is used as a shut-off valve in the food and beverage industry, in pharmaceutical and chemical engineering, as well as in bio-engineering.

2.2 General notes



NOTICE - observe the operating instructions

To avoid danger and damage, the fitting must be used in accordance with the safety instructions and technical data contained in the operating instructions.



NOTICE

All data are in line with the current state of development. Subject to change as a result of technical progress.

2.3 General safety instructions



WARNING

Risk of injury by moving parts

Do not grab into the valve when the actuator is pressurized. Limbs can be crushing or amputating.

- Remove the control air line before dismantling.
- Ensure that the actuator is unpressurized.



WARNING

Risk of injury by outflowing medium

Dismantling the valve or valve assemblies from the plant can cause injuries.

- Medias flowing through the leakage drain outlet are to be drained off without splashing into a discharge arrangement.
- Carry the disassembling only if when the plant has been rendered pressure-less and free of liquid and gas.



WARNING

ATEX - Guidelines

If the valve or the plant is operated in a potentially explosive atmosphere, the valid ATEX directive of the EC and the installation instructions in this operating manual must be observed.



CAUTION

To avoid air leaking, only use pneumatic connection parts that have an O-ring seal facing the even surface.



CAUTION

Before starting the system, the entire pipeline system must be thoroughly cleaned.



CAUTION

Steps should be taken to ensure that no external forces are exerted on the fitting.

3 Delivery, transport and storage

3.1 Delivery

- Immediately after receipt check the delivery for completeness and transport damages.
- Remove the packaging from the product.
- Retain packaging material, or expose of according to local regulations.

3.2 Transport



CAUTION

Risk of injury and damage to the product

During the transport the generally acknowledged rules of technology, the national accident prevention regulations and company internal work and safety regulations must be observed.

3.3 Storage



NOTICE

Damage to the product due to improper storage!

Observe storage instructions

avoid a prolonged storage



INFORMATION





















Recommendation for longer storage

We recommend regularly checking the product and the prevailing storage conditions during long storage times.

- To avoid damage to seals and bearings,
 - products up to DN 125 / OD 5 inch should be stored horizontally for maximum 6 months.
 - products larger than DN 125 / 5 inch, should be stored in the upright position with the actuator on top.
- Don't store any objects on the products.
- Protect the products for wetness, dust and dirt.
- The product should be stored in a dry and well ventilated room at a constant temperature (optimal indoor temperature: 25 C ±5 ; indoor humidity data 70% ±5%).
- Protect seals, bearings and plastic parts for UV light and ozone.

4 Specification





4.1 Modular system

Control - and feedback units					
Electronic control head KI-TOP		Electro-pneumatical positioner		Position indication with sensor mounting	
 transparent stainless steel					
drive systems					
pneumatical				electrical	
PDA 90/75 Ø 75	PDA 90/100 Ø 100	PDA 90/125 Ø 125	Type 4040		
					
manually operated					
hand lever	hand lever with sensor mounting	hand lever stainless steel	hand lever continuously adjustable		
					
connection flanges					
S	G	K/M	FI	CI	intermediate flange S
					
seals					
Silicone	EPDM	FKM	HNBR		
					

4.2 Valve types

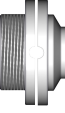
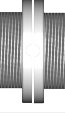
- S = Welded end
- G = Male
- K/M = Liner / nut
- Fl = Flange
- Cl = Clamp

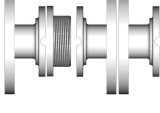
- lö = air open
- ls = air close
- fö = spring open
- fs = spring close

Butterfly valve			manually operated	pneumatical	
				NC	DA
	S - S	DIN	4301	4501	4401
		Inch	4351	4551	4451
	G - S	DIN	4302	4502	4402
		Inch	4352	4552	4452
	G - G	DIN	4303	4503	4403
		Inch	4353	4553	4453
	K/M - G	DIN	4304	4504	4404
		Inch	4354	4554	4454
	K/M - S	DIN	4305	4505	4405
		Inch	4355	4555	4455
	Fl (PN10) - G	DIN	4307	4507	4407
	Fl - Fl (PN10)				
	Cl - Cl	DIN	4346	4546	4446
		Inch	4347	4547	4447
Intermediate - butterfly valve			manually operated	pneumatical	
				NC	DA
	S - S	DIN	4310	4510	4410
		Inch	4358	4558	4458

5 Function and operation

5.1 Description of function

Open or close the valve by turning the pneum. controlled rotary drive by 90°.

Functional description for butterfly valves - manual operation

When actuating a fitting manually, the respective switching position will be locked in place in the final position. The manually operated lever is positioned at an angle of 90° in transverse direction to the conduit axis in closed position. The lever is positioned in the direction of the conduit axis in open position.

Description of function for butterfly valves - pneum. operation

The valve opens and closes by way of a pneum. multiturn actuator with a rotary movement of 90°.

normal closed (NC)

- pneum. OPERATED opens the valve
- not pneum. OPERATED spring force closes the valve

normal open (NO)

- pneum. OPERATED closes the valve
- not pneum. OPERATED spring force opens the valve

double acting (DA)

- pneum. OPERATED the valve opens or closes according to control

Functional description for leakage - butterfly valves

When closed, the butterfly valve with a tandem seal ensures that different media remain separated without leaking. The medium flows depressurized through the leakage drain ring-groove and out the leakage drain outlet. For hygienically demanding products, we recommend cleaning the leakage drain area (Cleaning connection R1/4").

5.2 Dry running

The butterfly valves should not be operated in dry-run mode for lengthy periods wherever this can be avoided, as this will lead to increased wear.

5.3 Control system and position indication



Feedback unit -optional-

Optionally, modular valve control head systems can be installed to the actuator for reading and actuating valve positions. The standard version is a closed system with SPS or ASI-bus switch-on electronics, and integrated 3/2-way solenoid valves. For tough operating conditions we recommend employing a high-grade steel cover.



Position indicator with sensor mounting for feedback signal.

The actuator is equipped with a proximity switch mounting (sensor mounting) and a position indication. When inductive proximity initiators M 12x1 are installed, the current "Open" or "Shut" position can be interrogated. By screwing the proximity initiator to the limit position the required switching gap for the signal transmission is established. When the valve is closed the position indication is oriented vertically to the direction of valve passage. When the valve is open it is oriented parallel to the valve passage.

Retrofitting to end position feedback for manually operated valves

By replacing the hand lever and the catch disc the valve can be retrofitted for end position feedback (proximity switch).

Conversion from manual operation to pneumatic actuation Operation

By a simple retrofitting operation the valve can be converted to pneumatic actuation. The rotary actuator for this purpose is supplied complete with fitting device. The following actuators are available, depending on the desired actuating function.

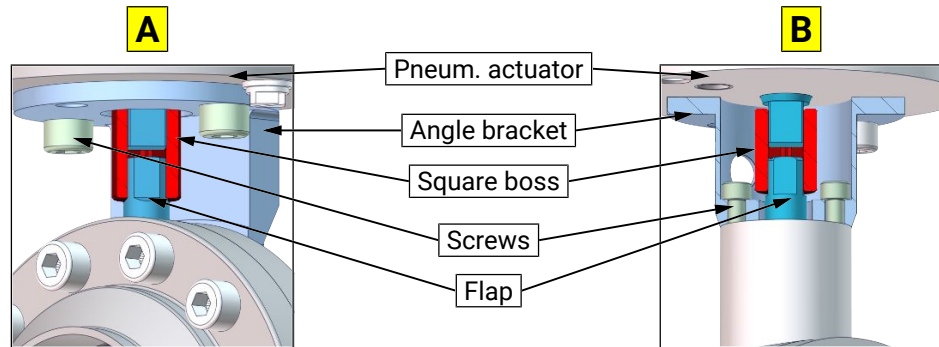

DN	15	20	25	40	50	65	80	100	125	150	200	Pneum. actuator	Conversion kit	Function
OD	-	-	1"	1½"	2"	2½"	3"	4"	-	-	-			
Butterfly valve [A]	A	A	A	A	-	-	-	-	-	-	-	PDA 90/75	4500.050.075-022 4500.050.075-022 -----	NC NO DA
	-	-	A	A	A	-	-	-	-	-	-	PDA 90/100	4500.050.100-022 4500.050.100-022 4400.050.100-022	NC NO DA
	-	-	-	-	-	A	A	A	-	-	-	PDA 90/100	4500.100.100-022 4500.100.100-022 4400.100.100-022	NC NO DA
	-	-	-	-	-	-	-	-	A	-	-	PDA 90/125	4500.125.125-022 4500.125.125-022 4400.125.125-022	NC NO DA
	-	-	-	-	-	-	-	-	-	A	-	PDA 90/125	4500.150.125-022 4500.150.125-022 4400.150.125-022	NC NO DA
	-	-	-	-	-	-	-	-	-	-	A	PDA 90/125	4500.200.125-022 4500.200.125-022 4400.200.125-022	NC NO DA
Leakage butterfly valve [B]	-	-	-	-	B	B	B	-	-	-	-	PDA 90/100	4200.080.100-022 4200.080.100-022 4100.080.100-022	NC NO DA
	-	-	-	-	-	-	-	B	-	-	-	PDA 90/125	4800.100.125-022 4800.100.125-022 4700.100.125-022	NC NO DA
	-	-	-	-	-	-	-	-	B	-	-	PDA 90/125	4200.100.125-022 4200.100.125-022 4100.100.125-022	NC NO DA

5.4 Pneumatic valve activation

Kind of actuator: air open - spring close (NC) / air close - spring open (NO)

Valve function	pneum. activation with solenoid valve in control head	pneum. activation with external solenoid valve
OPEN	control air feed P → MV2 → P2/LA2 Valve is opening by control air	control air feed ext. MV → LA2 Valve is opening by control air
CLOSED	de-aeration LA2/P2 → MV2 → R valve is closing by spring	de-aeration LA2 → ext. MV valve is closing by spring

Kind of actuator: air open - air close (DA)

Valve function	pneum. Activation via control head with solenoid valves	pneum. Activation via external solenoid valves
OPEN	control air feed P → MV2 → P2/LA2 Valve is opening by control air	control air feed ext. MV → LA2 Valve is opening by control air
CLOSED	control air feed P → MV1 → P1/LA1 Valve is closing by control air	control air feed ext. MV → LA1 Valve is closing by control air

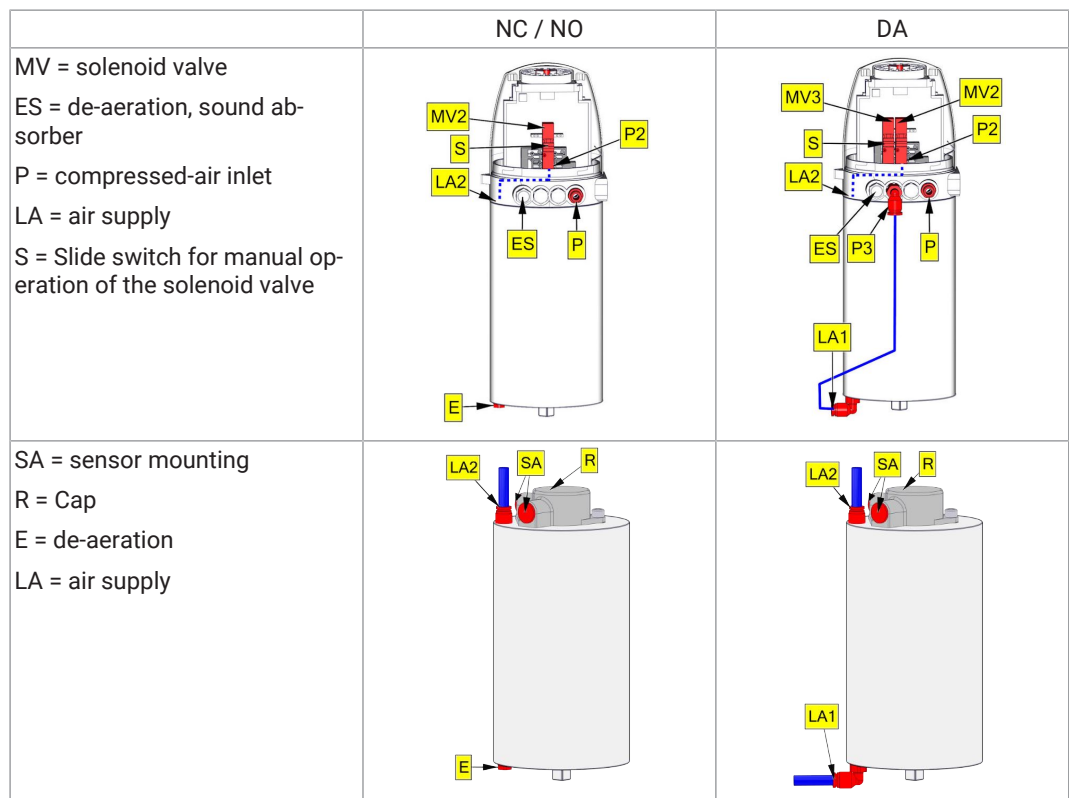

6 Commissioning, service and maintenance

6.1 Commissioning

6.1.1 Installation instructions

Fitting position

For valves without leakage outlet, the installation position is without importance.

Leakage - disk valves must always be installed vertically to ensure that outflow of leakage, or of cleaning medium, from the valve is such that no residue will remain inside the valve.

For valves which are to be welded in on both sides, a releasable connection has to be fitted into the pipework to allow dismounting (maintenance).

6.1.2 General welding guidelines

Sealing elements integrated in weld components must generally be removed prior to welding. To prevent damage, welding should be undertaken by certified personnel (EN ISO 9606-1). Use the TIG (Tungsten Inert Gas) welding process.



⚠ CAUTION

Damage and injuries due to high temperature supply

To avoid a distortion of the components, all welding parts must be welded to stress-relieved.

Allow all components to cool before assembling.



NOTICE

Damage due to impurities

Impurities can cause damage to the seals and seals area.

Clean inside areas prior to assembly.

6.1.3 ATEX - Guidelines

For valves or plants/installations that are operated in the ATEX area, sufficient bonding (grounding) must be ensured (see valid ATEX Guidelines EG).

6.2 Service



RECOMMENDATION

Replacement of seals

To achieve optimal maintenance cycles, the following points must be observed!

- When replacement of seals, all product-contacting seals should be replaced.
- Only original spare parts may be installed.

Maintenance interval

The maintenance intervals depend on the operating conditions "temperature, temperature-intervals, medium, cleaning medium, pressure and opening frequency". We recommend replacing the seals 1-year cycle. The user, however should establish appropriate maintenance intervals according to the condition of the seals.

Lubricant recommendation

	EPDM; HNBR; NBR; FKM; k-flex	- Klüber Paraliq GTE703*
	Silicone	- Klüber Sintheso pro AA2*
	Thread	- Interflon Food*
*) It is only permitted to use approved lubricants, if the respective fitting is used for the production of food or drink. Please observe the relevant safety data sheets of the manufacturers of lubricants.		

6.3 Cleaning**Cleaning**

For best cleaning results, keep the valve open during cleaning to completely rinse the gasket and the valve head.

7 Technical data

7.1 Butterfly valve / Intermediate flanged - butterfly valve

Valve size:	Butterfly valve : DIN: DN 10 - DN 150; Inch: DN 1" - DN 4" Intermediated flanged butterfly valve: DIN: DN 15 - DN 200; Inch: DN 1" - DN 4"	
Connections:	Welding flange PN10 Male part DIN11851 Liner/nut DIN11851 Clamp coupling DIN32676 Male part (RJT) (special flange)	
Temperature range:	Ambient temperature: Product temperature: Sterilization temperature:	+4° to +45°C +0° to +95°C (medium dependent) EPDM +140°C (SIP 30 min) HNBR +95°C (SIP 30 min) Silicone +110°C (SIP 30 min) FKM +90°C (SIP 30 min)
Operating pressures:	<u>Working pressure:</u> DN 10 - DN 65 / DN 1" - DN 2½" = 16 bar * DN 80 - DN 100 / DN 3" - DN 4" = 10 bar DN 125 - DN 200 = 6 bar *) Valves with flange coupling PN10 may be used only with a working pressure up to 10 bar.	
Leak rate:	A (DIN EN 12266-1)	
Control air: (only pneum. operation valves)	<u>Control air pressure:</u> 5,5 - 8,0 bar	<u>Quality of control air:</u> ISO 8573-1 : 2001 quality class 3
Materials: in product contact	Stainless steel:	1.4301 / AISI304 1.4307 / AISI304L 1.4404 / AISI316L
	Surfaces:	Ra < 0,8µm e-polished
	Material of seals:	EPDM (FDA); HNBR (FDA); Silicone (FDA); FKM (FDA)

7.2 Leakage - butterfly valves

Valve size:	DIN: DN 50 - DN 150 Inch: DN 2" - DN 4"	
Connections:	Welding flange K-welding flange PN10 Nr. 2069 Male part DIN11851 Liner/nut DIN11851	
Temperature range:	Ambient temperature: Operating temperature: Sterilization temperature:	+4 to +45°C (air) +0 to +95°C (medium dependent) EPDM +140°C (SIP 30 min) HNBR +95°C (SIP 30 min) Silicone +110°C (SIP 30 min)
Operating pressures:	<u>Working pressure:</u> DN 50 - DN 100/ DN 2" - DN 4" = 10 bar DN 125 - DN 150 = 6 bar <u>Cleaning pressure (Medium water):</u> Cleaning of the leakage line with product-subjected valve: - max. 1 bar Cleaning of the leakage line with the pipe cleaning: - max. 3 bar	
Leak rate:	A (DIN EN 12266-1)	
Control air: (only pneum. operation valves)	<u>Control air pressure:</u> 5,5 - 8,0 bar	<u>Quality of control air:</u> ISO 8573-1 : 2001 quality class 3
Materials: in product contact	Stainless steel:	1.4301 / AISI304 1.4307 / AISI304L 1.4404 / AISI316L
	Surfaces:	Ra < 0,8µm e-polished
	Material of seals:	EPDM (FDA); HNBR (FDA); Silicone (FDA)

8 Disassembly and assembly

8.1 Disassembly

Dismount the drive system

Hand lever: Unscrew the screw (H1) and remove the hand lever (H).

Pneum. multiturn actuator PDA75, PDA100

- Butterfly valve

Schrauben (A4) ausschrauben und Antrieb (A) mit der Vierkantnabe (A1) abnehmen.

- Leakage butterfly valve

Schrauben (A1) ausschrauben und Antrieb (A) mit der Vierkantnabe (A1) abnehmen.

Pneum. multiturn actuator PDA125:

- Butterfly valve

Unscrew the screw joints (A4) - (A5) and remove the actuator (A) with the square boss (A1).

- Leakage butterfly valve

Unscrew the upper both screw joints (5 a,b,d) / (7) and remove the screws (7). Remove actuator (A) and square boss (A1).

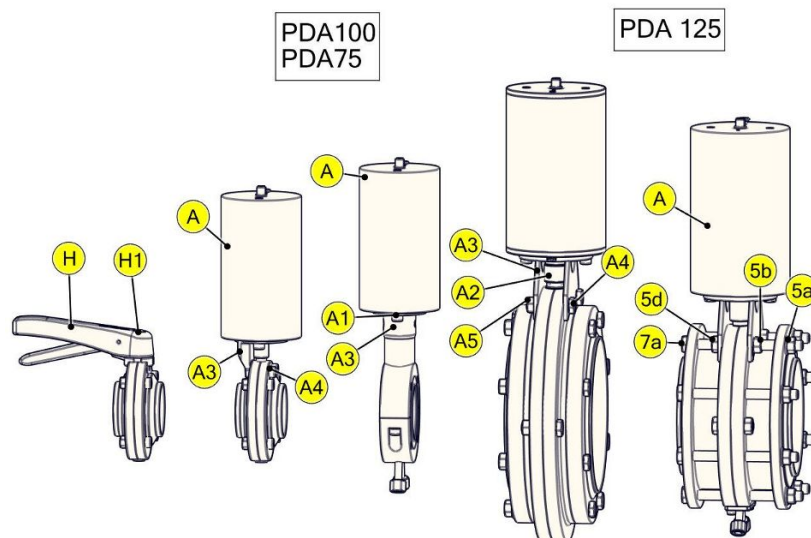

Dismount seal (3)

- Butterfly valve DN10 - DN150

Unscrew the screw joints (4) - (5). Remove housing flange (1a) and (1b).
Unscrew the screw joints (5a) - (7). Remove the flange (8) and dismantle seals (9).
Unscrew the screw joints (4) - (5b) and remove the housing flange (1).

- Intermediate flange-butterfly valve DN200

Unscrew the screw joints (5a) - (7).

Remove the flange (8) and dismantle seals (9).

Unscrew the screw joints (4) - (5b) and remove the housing flange (1).

Remove scraper ring (11) and plain bearing (6). Remove the back-up rings (3a) and (3b) from the seal (3).

- Leakage-butterfly valve DN50 - DN125

Dismount the leakage drain. Unscrew the screw joints (4) - (5). Radially remove the valve from the flange connection. Unscrew the screws (A4) and remove the bracket (A3). Unscrew the screws (7) and remove the washers (6).

Remove the lower housing part (1b).



Develop out of the upper housing part (1a) the seal (3) with the flap (2).

- Leakage-butterfly valve DN150

Unscrew the screws (14). Remove the cap (13) and seal (12). Unscrew the screw joints (5 a,b,d) / (7) and remove the screws (7). Remove the bracket (A3), flange (8) and seals (10). Unscrew the screw joints (5c) / (4) and remove screws (4).

Remove flanges (1). Remove the plain bearing (9),(11) and disc (15).

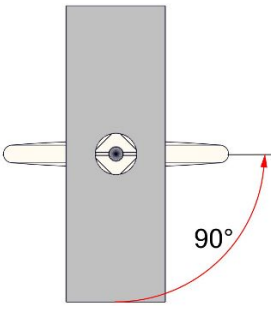
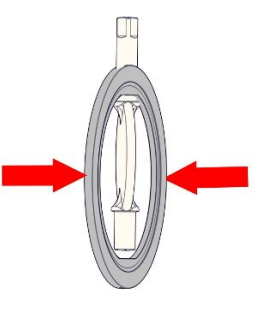
Dismount seal (3) from the flap (2).

		
<p>Position the flap (2) in open position to seal (3)</p>	<p>Deform seal (3) oval-shaped with manual force</p>	<p>Remove the flap (2) with the short shaft end from seal (3)</p>

8.2 Assembly

Thoroughly clean and slightly lubricate mounting areas and running surfaces.
Assemble in reverse order.



NOTICE

During assembly, the following points must be observed!

- Grease the two shafts of the flap (2) before inserting it into the seal (3) using a grease that is suitable for foods.
- Mount the locking disc (H2) up to the metal stop on the housing flanges. Possibly tap lightly with a soft face hammer and a sleeve.

- When mounting the hand lever (H), be sure the lever orientation is matched up with the position slot at the square shaft.
 - In this way the correct indication of the valve position by the hand lever is ensured.

- Do not install the actuator when set to pneumatic actuation (spring closing condition). Close flap (2) (spring closing position) before assembling the actuator (A). The position indicator is oriented vertically to valve passage direction - valve position "shut".

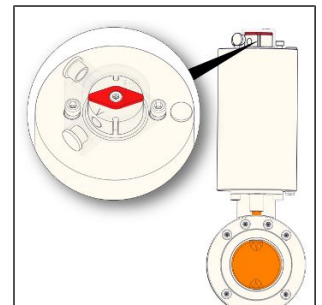
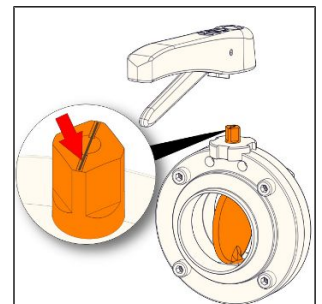
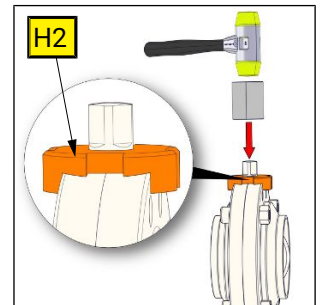

9 Drawings and dimensions

9.1 Butterfly valve

Drawings

(Illustration: G-S, without drive system)

1a = Housing flange with welding end

1b = Housing flange with thread end

2 = Flap

3 = Seal

4 = Screws

5 = Nuts

K1 = Cap

K2 = Cap

K3 = Cap

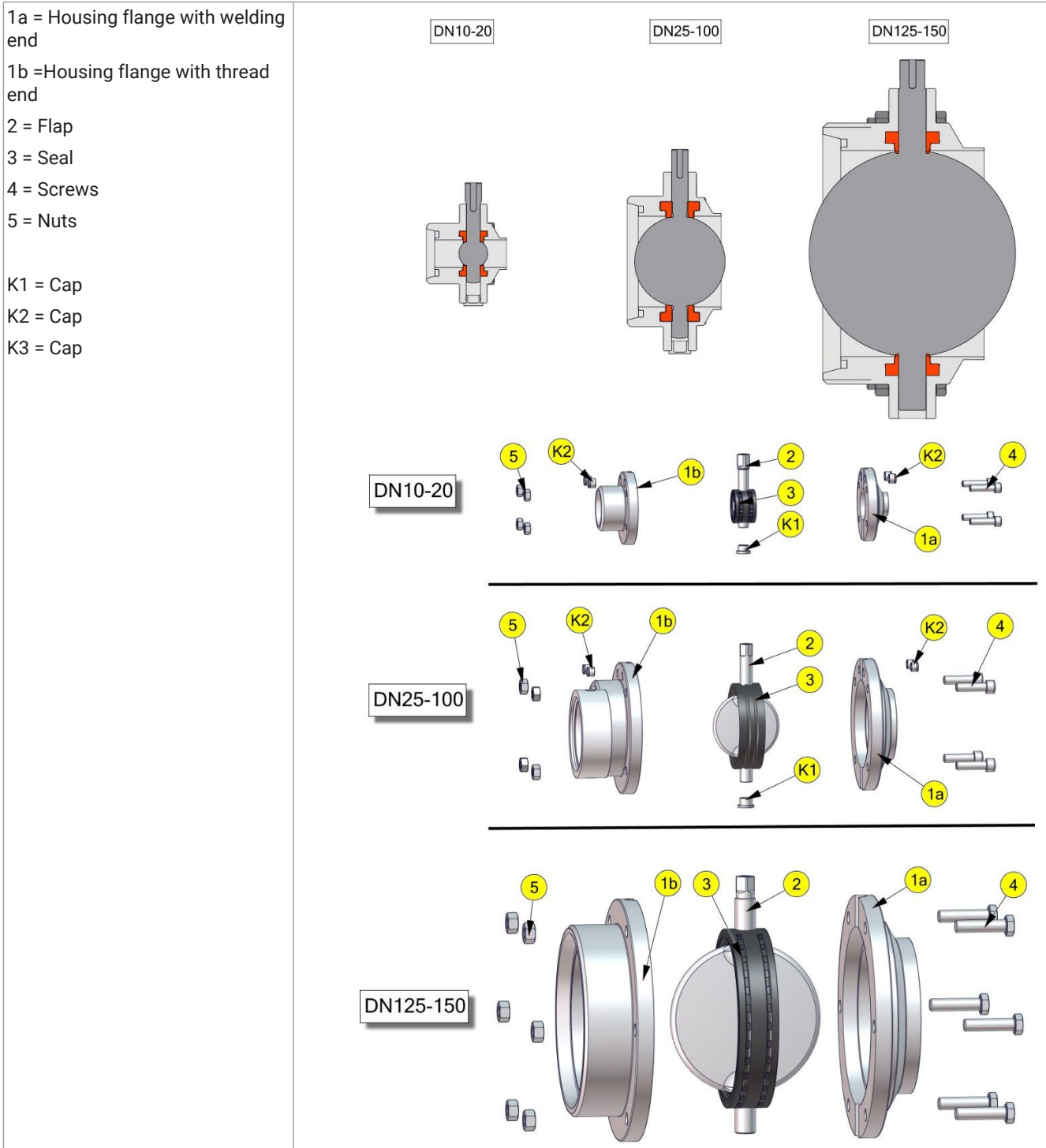

Dimensions

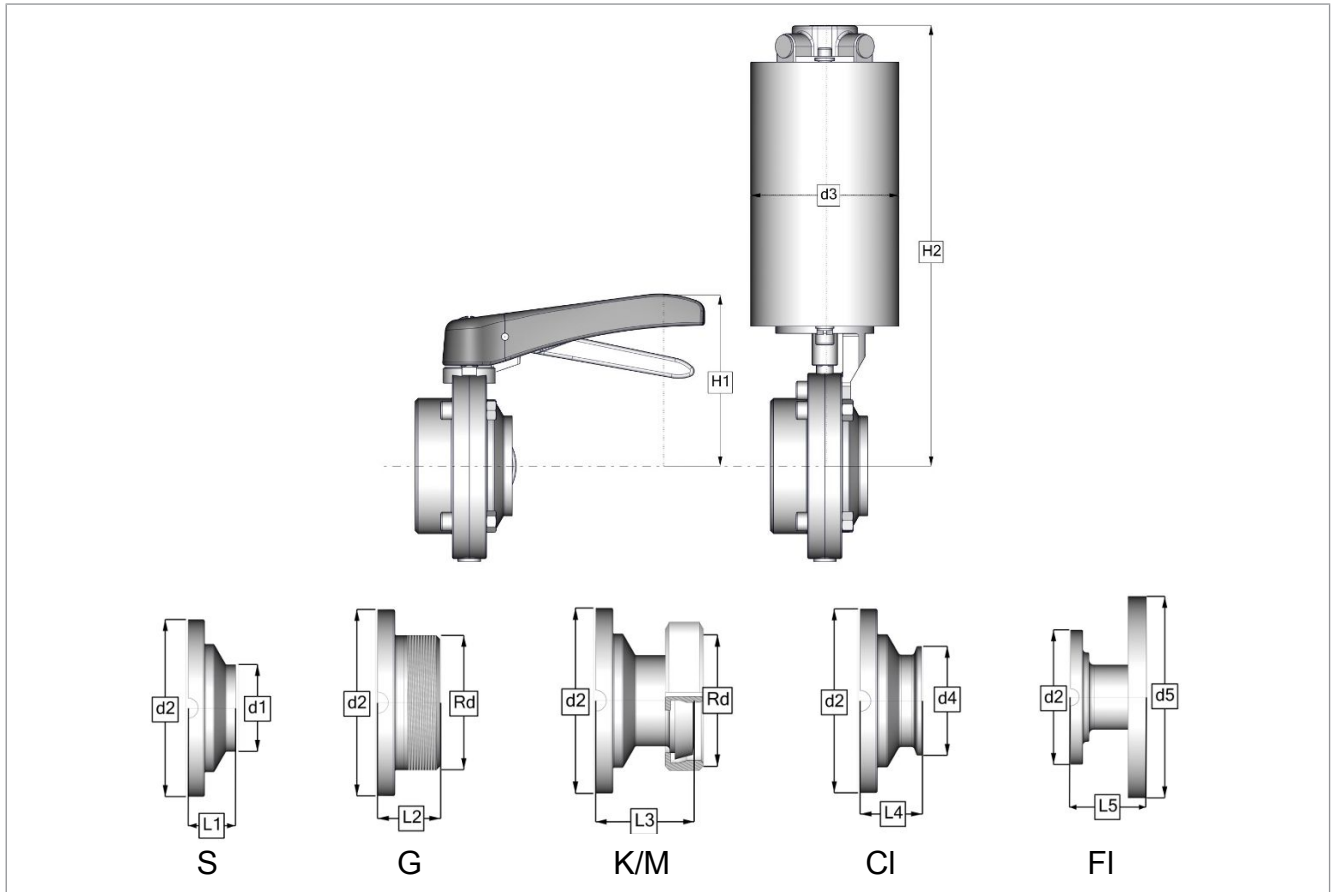

DN / OD	d1	d2	d3	d4	d5	L1	L2	L3	L4	L5	H1	H2	Rd
10 (ø10)	ø13x1,5	ø62	ø76	-	-	24	41	-	-	-	78	232	Rd28x1/8
15 (ø16)	ø19x1,5	ø62	ø76	ø34	-	24	34	41	34	-	78	232	Rd34x1/8
20 (ø20)	ø23x1,5	ø72	ø76	ø34	-	24	34	42	34	-	83	237	Rd44x1/6
25 (ø26)	ø29x1,5	ø80	ø104	ø50,5	ø115	27	34	49	34	66	95	285	Rd52x1/6
32 (ø32)	ø35x1,5	ø86	ø104	ø50,5	ø140	27	34	52	34	66	98	288	Rd58x1/6
40 (ø38)	ø41x1,5	ø92	ø104	ø50,5	ø150	27	34	53	34	60	101	291	Rd65x1/6
50 (ø50)	ø53x1,5	ø108	ø104	ø64	ø165	29	36	57	36	65	109	300	Rd78x1/6
65 (ø66)	ø70x2	ø130	ø104	ø91	ø185	30	38	62	38	73	121	311	Rd95x1/6
80 (ø81)	ø85x2	ø146	ø104	ø106	ø200	36	44	73	44	70	129	319	Rd110x1/4
100 (ø100)	ø104x2	ø166	ø104	ø119	ø220	34	44	78	44	77	139	329	Rd130x1/4
125 (ø125)	ø129x2	ø205	ø129	-	ø250	43	55	77	-	82	181	388	Rd160x1/4
150 (ø150)	ø154x2	ø240	ø129	-	ø285	52	65	89	-	91	200	407	Rd190x1/4
1" (ø22,1)	ø25,4x1,65	ø80	ø104	ø50,5	-	27	34	49	34	-	95	285	Rd52x1/6
1½" (ø34,8)	ø38,1x1,65	ø92	ø104	ø50,5	-	27	34	53	34	-	101	291	Rd65x1/6
2" (ø47,5)	ø50,8x1,65	ø108	ø104	ø64	-	29	36	57	29	-	109	300	Rd78x1/6
2½" (ø60,2)	ø63,5x1,65	ø130	ø104	ø77,5	-	30	38	62	38	-	121	311	Rd95x1/6
3" (ø72,9)	ø76,2x1,65	ø146	ø104	ø91	-	36	44	73	44	-	129	319	Rd104x1/6
4" (ø97,4)	ø101,6x2,11	ø166	ø104	ø119	-	34	44	78	44	-	139	329	Rd130x1/4

9.2 Intermediate flange-butterfly valves

Drawings

Intermediate flange-butterfly valve DN15 - DN150 / 1Inch - 4Inch

- 1= Housing flange
- 2= Flap
- 3= Seal
- 4= Screws
- 5= Nut
- 6= Discs
- 7= Screws
- 8= Flanges
- 9= Seals

- K1) Cap
- K2) cap

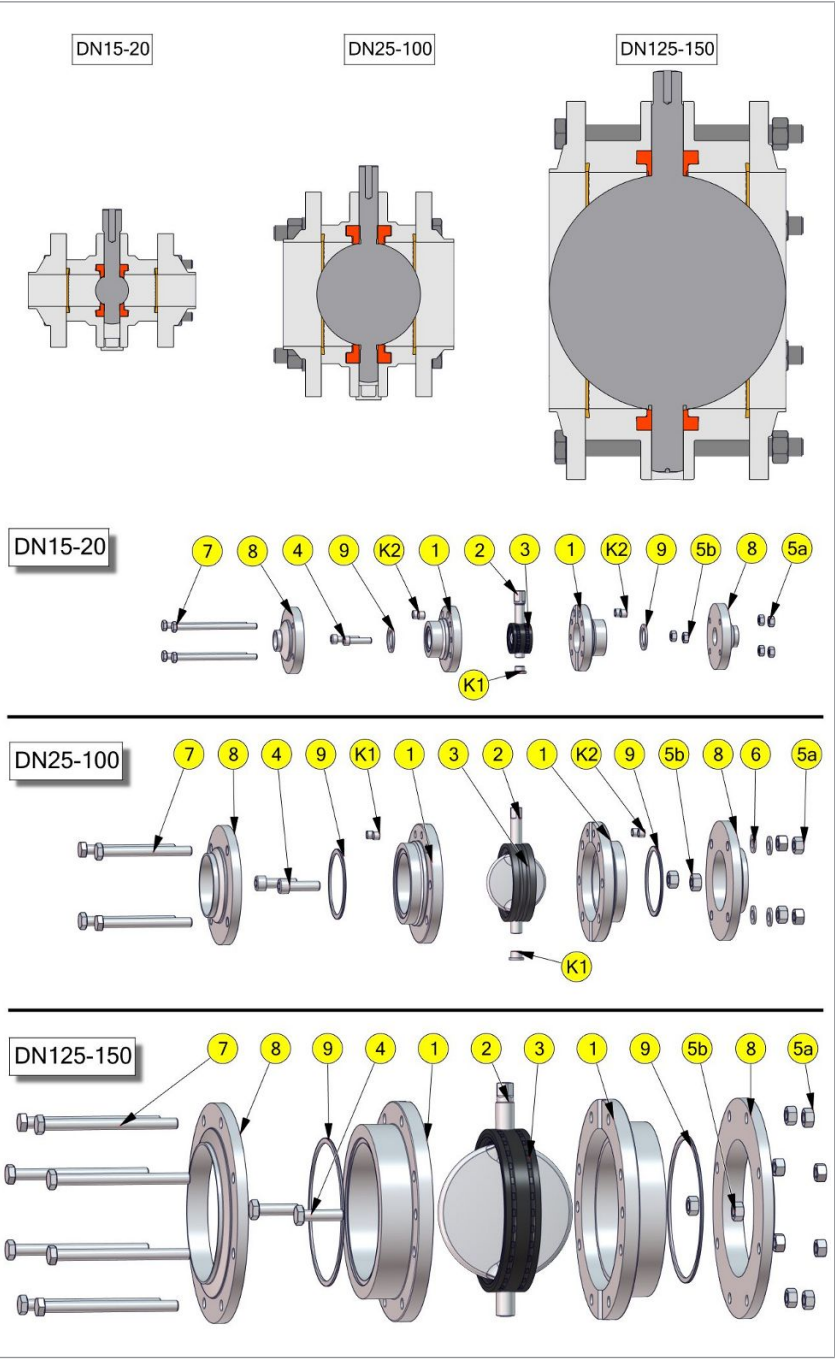

Drawing

Intermediate flange-butterfly valve DN200

- 1 = Housing flanges
- 2 = Flap
- 3 = Seal
- 3a) = Backup ring upper
- 3b) = Backup ring lower
- 4 = Screws
- 5 = Nuts
- 6 = Plain bearing
- 7 = Screws
- 8 = Flange
- 9 = Seals
- 10 = Discs
- 11 = Scraper ring

- H = Hand lever
- H1 = Screw
- H2 = Locking disc

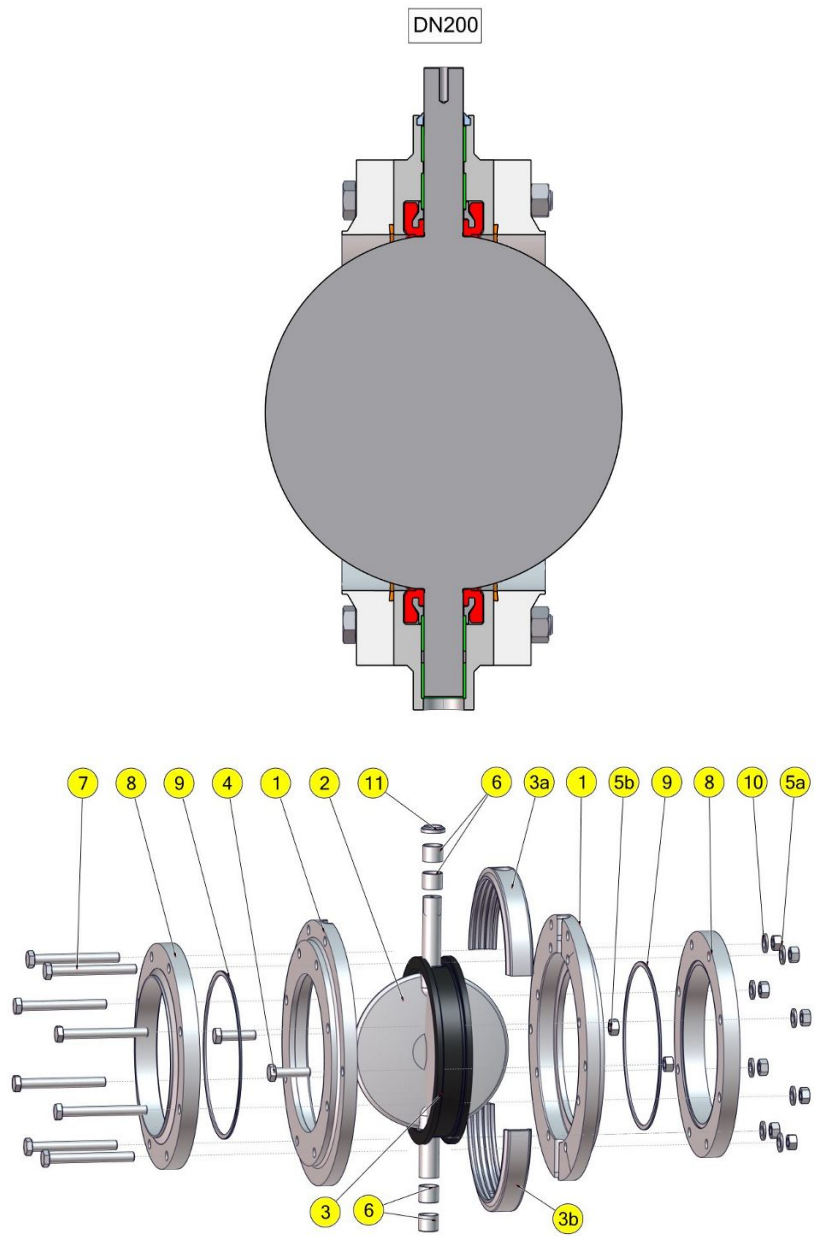

Dimensions

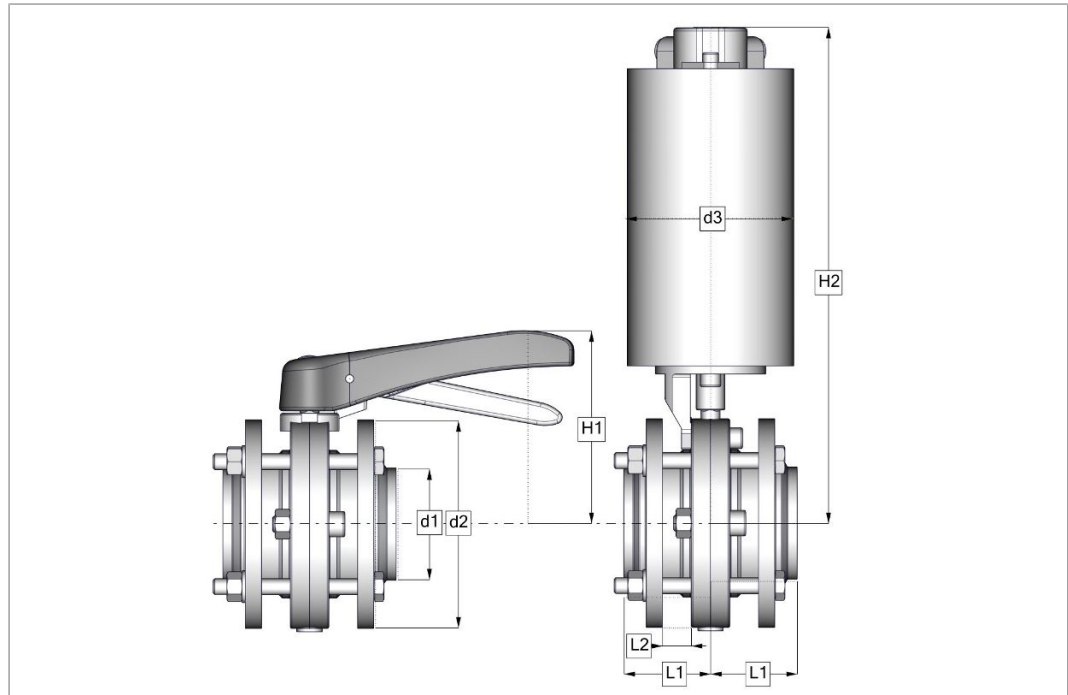

DN/OD	d1	d2	d3	L1	L2	H1	H2
15 (ø16)	ø19x1,5	ø62	ø76	53	29	78	232
20 (ø20)	ø23x1,5	ø72	ø76	53	29	83	237
25 (ø26)	ø29x1,5	ø80	ø104	51	27	95	285
32 (ø32)	ø35x1,5	ø86	ø104	51	27	98	288
40 (ø38)	ø41x1,5	ø92	ø104	51	27	101	291
50 (ø50)	ø53x1,5	ø108	ø104	53	29	109	300
65 (ø66)	ø70x2	ø130	ø104	54	30	121	311
80 (ø81)	ø85x2	ø146	ø104	60	36	129	319
100 (ø100)	ø104x2	ø166	ø104	58	34	139	329
125 (ø125)	ø129x2	ø205	ø129	66	43	181	388
150 (ø150)	ø154x2	ø240	ø129	75	52	200	407
200 (ø200)	ø204x2	ø334	ø129	57	28	247	455,5
1" (ø22,1)	ø25,4x1,65	ø80	ø104	51	27	95	285
1½" (ø34,8)	ø38,1x1,65	ø82	ø104	51	27	101	291
2" (ø47,5)	ø50,8x1,65	ø108	ø104	53	29	109	300
2½" (ø60,2)	ø63,5x1,65	ø130	ø104	54	30	121	311
3" (ø72,9)	ø76,2x1,65	ø146	ø104	60	36	129	319
4" (ø97,4)	ø101,6x2,11	ø166	ø104	58	34	139	329

9.3 Leakage butterfly valve

Drawings

Leakage butterfly valves DN 50 - DN 125 / OD 2inch - OD 4inch

(Illustration basic valve Type: LSV 4365 DN65)

1a = upper housing part

1b = lower housing part

2 = Flap

3 = Seal

4 = Screws

5 = Nuts

6 = Discs

7 = Screws

8 = Flange with

) a) Welding connection (2069)

) b) Welding connection (2041)

) c) Male connection

) d) Liner / nut - connection

9 = Plain bearing

10 = Straight pins

A = Actuator

A1 = Square boss

A2 = Angle bracket

A3 = Screws

A4 = Screws

H = Hand lever

H1 = Saucer-head screw

H2 = Locking disc

H3 = Screws

L = Leakage drain

LA = air supply

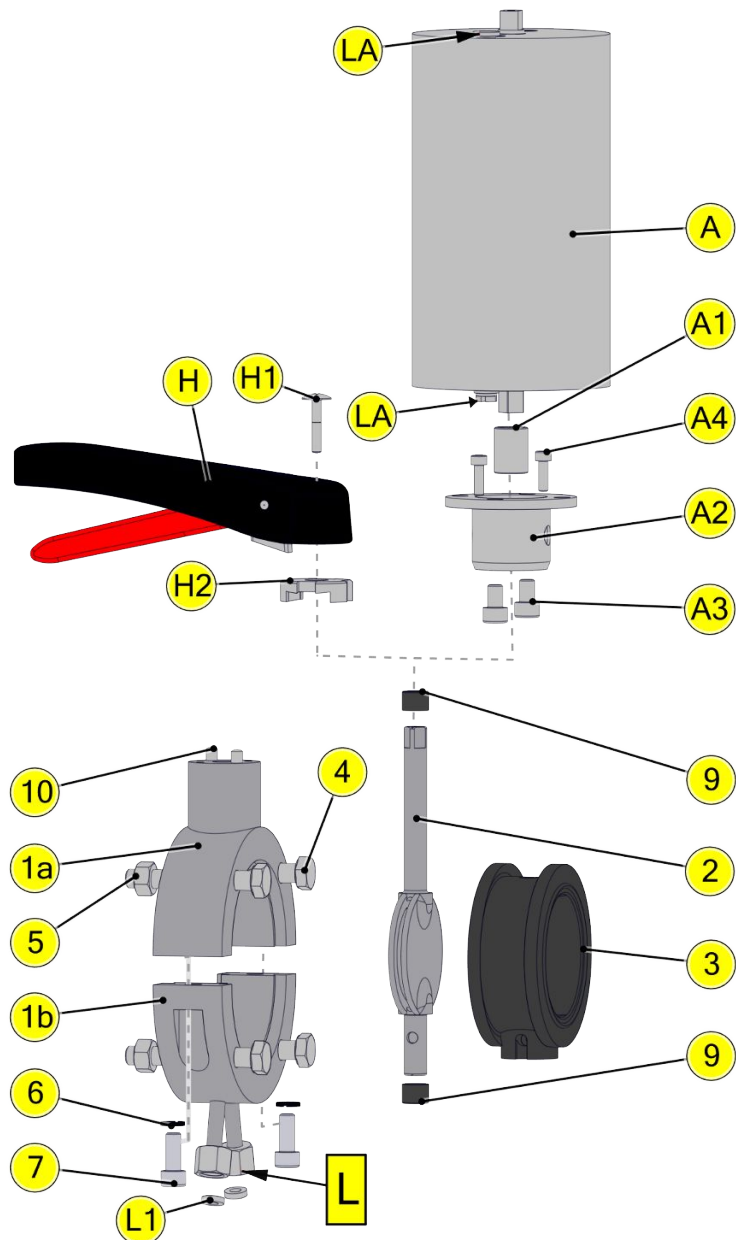

Drawing

Leakage - butterfly valves DN150

- 1 = Housing flange
- 2 = Flap
- 3 = Seal
- 4 = Screws
- 5 = Nuts
- 6 = Discs
- 7 = Screws
- 8 = Welding flange
- 9 = Plain bearing
- 10 = O-rings
- 11 = Plain bearing
- 12 = Seal
- 13 = Cap
- 14 = Screw
- 15 = Seal
- 16 = Disc

- A = Actuator
- A1 = Square boss
- A2 = Angle bracket
- A3 = Screws

- H = Hand lever
- H1 = Screw
- H2 = Locking disc

- L = Leakage drain
- LA = air supply

Dimension

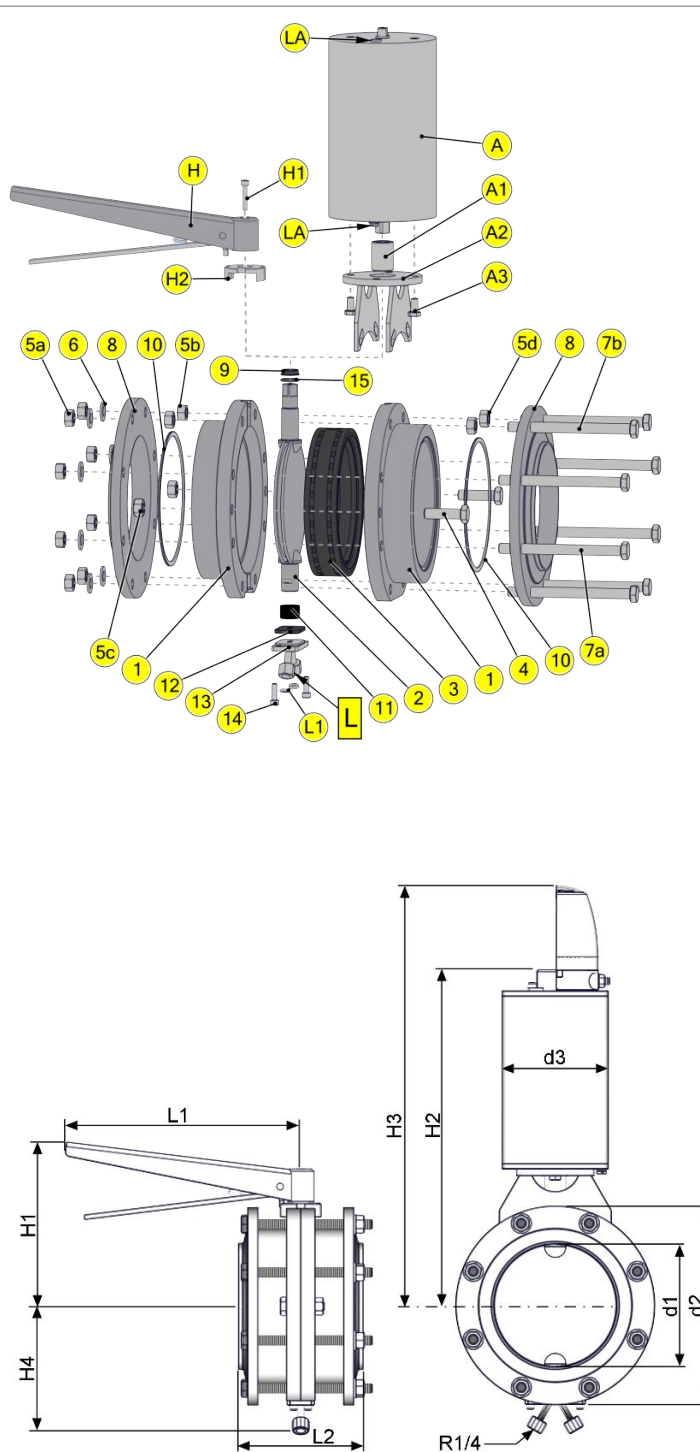

DN / OD	d1	d2	d3	L1	L2	H1	H2	H3	H4
150 (ø150)	ø154x2	ø240	ø129	285	68	199	406	510	155

Dimensions

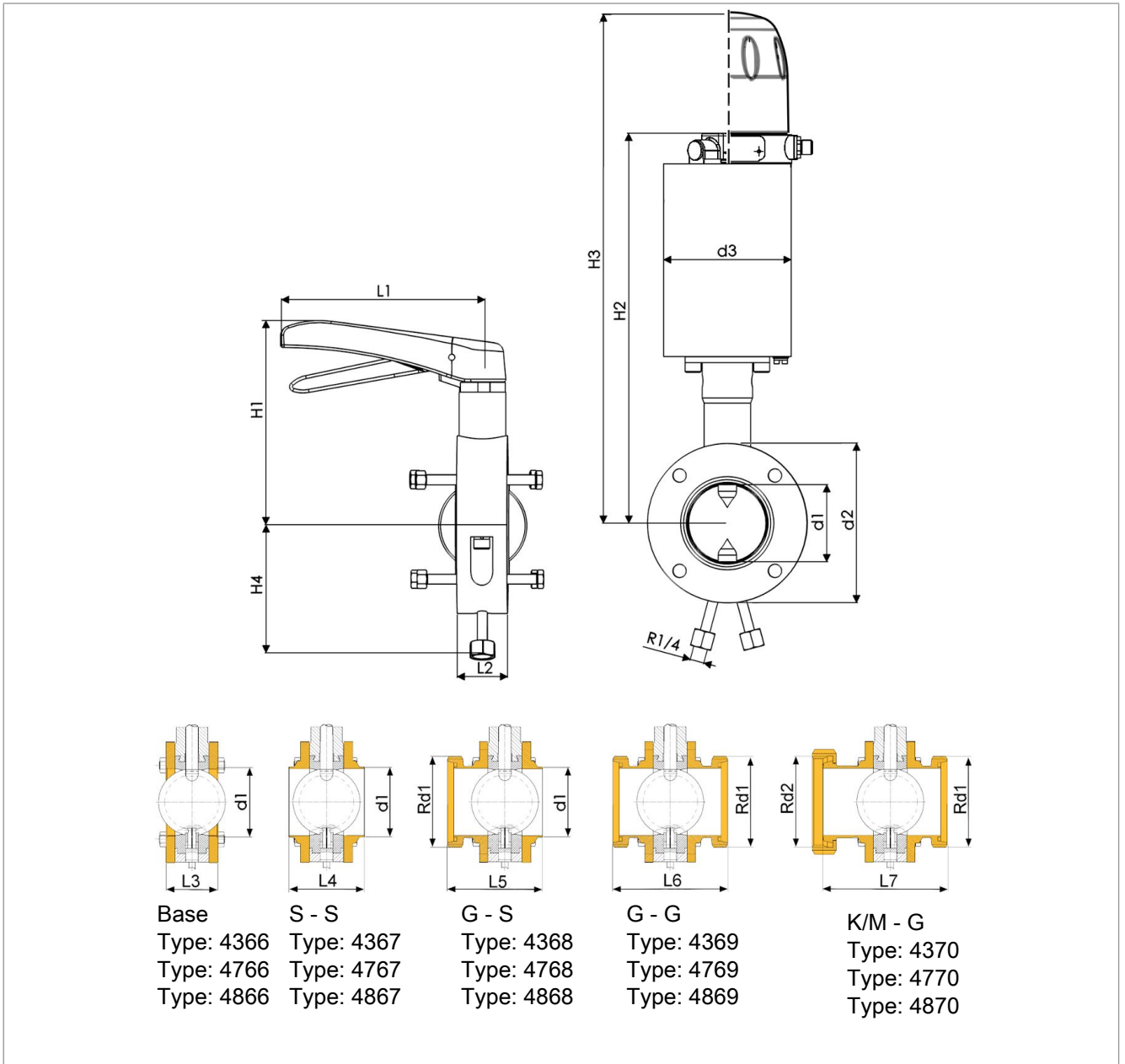

DN / OD	d1	d2	d3	L1	L2	L3	L4	L5	L6	L7	H1	H2	H3	H4	Rd1/Rd2
50 (ø50)	ø53x1,5	ø110	ø104	165	38	68	86	109	156	149	148	338	440	84	Rd78x1/6
65 (ø66)	ø70x2	ø130	ø104	165	38	68	86	111	166	158	158	349	451	94	Rd95x1/6
80 (ø81)	ø85x2	ø145	ø104	165	41	71	89	114	179	158	167	358	460	102	Rd110x1/4
100 (ø100)	ø104x2	ø165	ø129	180	41	71	89	118	197	187	178	407	509	112	Rd130x1/4
125 (ø125)	ø129x2	ø195	ø129	285	53	87	101	145	193	181	214	421	523	127	Rd160x1/4
2" (ø47,5)	ø50,8x1,65	ø110	ø104	165	38	68	86	-	-	-	148	338	440	84	Rd78x1/6
2½" (ø60,2)	ø63,5x1,65	ø130	ø104	165	38	68	86	-	-	-	158	349	451	94	Rd95x1/6
3" (ø72,9)	ø76,2x1,65	ø145	ø104	165	41	71	89	129	169	-	167	358	460	102	Rd104x1/6
4" (ø97,4)	ø101,6x2,11	ø165	ø104	180	41	87	101	-	-	-	178	407	509	112	Rd130x1/4

9.4 drive systems

Multiturn actuator (PDA)

<ul style="list-style-type: none"> • A) Actuator <ul style="list-style-type: none"> – PDA 75 – PDA 100 – PDA 125 • A1) Screws • A2) Square boss • A3) Angle bracket • A4) Screws • A5) Nuts • R) Position indication with sensor mounting 		<table border="1"> <thead> <tr> <th>DN</th> <th>L</th> <th>s</th> <th>s1</th> </tr> </thead> <tbody> <tr> <td>10 - 20</td> <td>168</td> <td>10</td> <td>10</td> </tr> <tr> <td>20 - 40</td> <td>168</td> <td>9.5</td> <td>10</td> </tr> <tr> <td>25 - 80</td> <td>210</td> <td>9.5</td> <td>10</td> </tr> <tr> <td>100</td> <td>210</td> <td>12</td> <td>10</td> </tr> <tr> <td>125</td> <td>240</td> <td>12</td> <td>16</td> </tr> <tr> <td>150</td> <td>240</td> <td>14</td> <td>16</td> </tr> </tbody> </table>	DN	L	s	s1	10 - 20	168	10	10	20 - 40	168	9.5	10	25 - 80	210	9.5	10	100	210	12	10	125	240	12	16	150	240	14	16			
DN	L	s	s1																														
10 - 20	168	10	10																														
20 - 40	168	9.5	10																														
25 - 80	210	9.5	10																														
100	210	12	10																														
125	240	12	16																														
150	240	14	16																														

Hand lever Standard

<table border="1"> <thead> <tr> <th>Model</th> <th>DN</th> <th>L</th> <th>s</th> </tr> </thead> <tbody> <tr> <td rowspan="2">hand lever Standard Type 4335</td> <td>10 - 50</td> <td>100</td> <td>10</td> </tr> <tr> <td>25 - 100</td> <td>165</td> <td>10</td> </tr> </tbody> </table>	Model	DN	L	s	hand lever Standard Type 4335	10 - 50	100	10	25 - 100	165	10				
Model	DN	L	s												
hand lever Standard Type 4335	10 - 50	100	10												
	25 - 100	165	10												
<table border="1"> <tbody> <tr> <td>Hand lever Standard - with sensor mounting Type 4321</td> <td>10 - 50</td> <td>100</td> <td>10</td> </tr> <tr> <td></td> <td>25 - 100</td> <td>165</td> <td>10</td> </tr> </tbody> </table>	Hand lever Standard - with sensor mounting Type 4321	10 - 50	100	10		25 - 100	165	10							
Hand lever Standard - with sensor mounting Type 4321	10 - 50	100	10												
	25 - 100	165	10												

Hand lever with continuously adjustable

Model		DN	L	s
Hand lever continuously adjustable Type 4600		10 - 20	165	10
		25 - 50	165	10
		65 - 100	230	10
		125	320	10
		150	320	14

Hand lever - stainless steel

Model		DN	L	s
Hand lever - stainless steel Type 4318		10 - 50	101	10
		25 - 50	146	10
		65 - 100	180	10
		125 - 150	285	14
		200	285	17
Hand lever - stainless steel with sensor mounting Type 4321		10 - 50	101	10
		25 - 50	146	10
		65 - 100	180	10
		125 - 150	285	14
		200	285	17

9.5 Control units

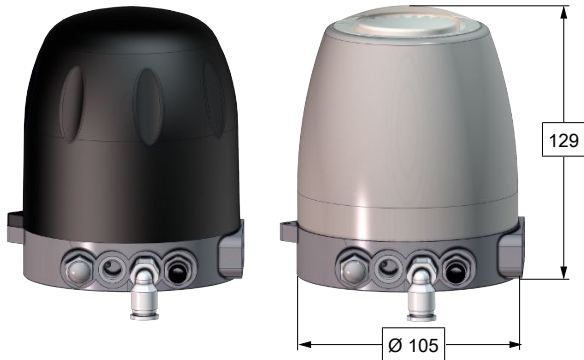
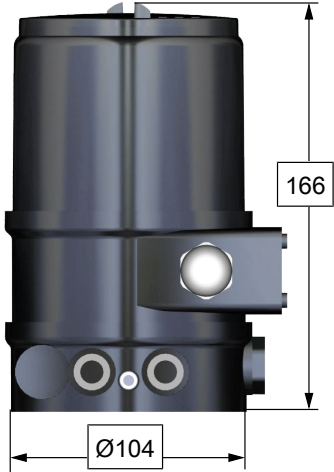
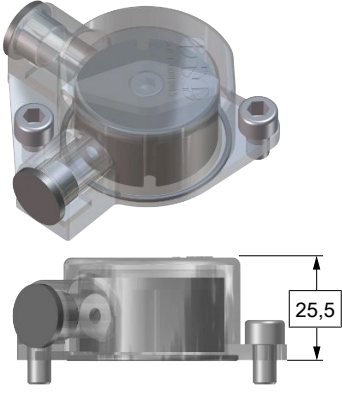
KI-TOP control head		positioner	Position indication with sensor mounting
1) with stainless steel hood	2) with transparent plastic hood		
			

Position indication with sensor mounting (R)

- R1) Dog
- R1.1 Straight pin
- R2) Position indication
- R3) O-rig
- R4 screw
- R5 Sensor mounting
- R6 Cap
- R7 Screw
-
- LA) Air supply
-
-

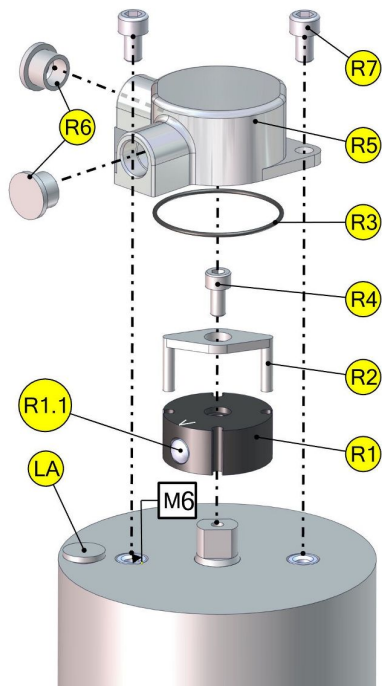

10 Wearing parts

10.1 Butterfly valve

DN	Seal (3)			
	SILICONE	EPDM	HNBR	FKM
15	-	4328 015 000-054	4326 015 000-050	-
20	-	4328 020 000-054	4326 020 000-050	-
25	4326 025 000-052	4328 025 000-054	4326 025 000-050	4327 025 000-051
32	4326 032 000-052	4328 032 000-054	4326 032 000-050	4327 032 000-051
40	4326 040 000-052	4328 040 000-054	4326 040 000-050	4327 040 000-051
50	4326 050 000-052	4328 050 000-054	4326 050 000-050	4327 050 000-051
65	4326 065 000-052	4328 065 000-054	4326 065 000-050	4327 065 000-051
80	4326 080 000-052	4328 080 000-054	4326 080 000-050	4327 080 000-051
100	4326 100 000-052	4328 100 000-054	4326 100 000-050	4327 100 000-051
125	4326 125 000-052	4328 125 000-054	4326 125 000-050	4327 125 000-051
150	4326 150 000-052	4328 150 000-054	4326 150 000-050	4327 150 000-051
1	4326 026 000-052	4328 026 000-054	4326 026 000-050	4327 026 000-051
1½	4326 038 000-052	4328 038 000-054	4326 038 000-050	4327 038 000-051
2	4326 051 000-052	4328 051 000-054	4326 051 000-050	4327 051 000-051
2½	4326 064 000-052	4328 064 000-054	4326 064 000-050	4327 064 000-051
3	4326 076 076-052	4328 076 076-054	4326 076 076-050	4327 076 076-051
4	4326 101 000-052	4328 101 000-054	4326 101 000-050	4327 101 000-051

10.2 Leakage - butterfly valves

DN	Seal (3)			Plain bearing (9)	Plain bearing (11)	Seal (L1)
	SILICONE	EPDM	HNBR	iglidur®		EPDM
50	4378 050 000-052	4377 050 000-054	4378 050 000-050	8050 012 010-060	8050 012 010-060	2354 012 006-054
65	4378 065 000-052	4377 065 000-054	4378 065 000-050	8050 012 010-060	8050 012 010-060	
80	4378 080 000-052	4377 080 000-054	4378 080 000-050	8050 015 010-060	8050 015 010-060	
100	4378 100 000-052	4377 100 000-054	4378 100 000-050	8050 015 010-060	8050 015 010-060	
125	-	4377 125 000-054	4378 125 000-050	8050 020 015-156	8050 020 015-156	
150	-	4328 150 000-054	4328 150 000-050	8050 018 006-060	8050 020 015-156	
2	4378 050 000-052	4377 050 000-054	4378 050 000-050	8050 012 010-060	8050 012 010-060	2354 012 006-054
2½	4378 065 000-052	4377 065 000-054	4378 065 000-050	8050 012 010-060	8050 012 010-060	
3	4378 076 000-052	4377 076 000-054	4378 076 000-050	8050 015 010-060	8050 015 010-060	
4	4378 100 000-052	4377 100 000-054	4378 100 000-050	8050 015 010-060	8050 015 010-060	

10.3 Intermediate - butterfly valve

DN	Seal (3)				Seal (9)
	SILICONE	EPDM	HNBR	FKM	k -flex
15	-	4328 015 000-054	4326 015 000-050	-	2353 021 016-114
20	-	4328 020 000-054	4326 020 000-050	-	2353 028 020-114
25	4326 025 000-052	4328 025 000-054	4326 025 000-050	4327 025 000-051	2353 035 026-114
32	4326 032 000-052	4328 032 000-054	4326 032 000-050	4327 032 000-051	2353 041 032-114
40	4326 040 000-052	4328 040 000-054	4326 040 000-050	4327 040 000-051	2353 047 038-114
50	4326 050 000-052	4328 050 000-054	4326 050 000-050	4327 050 000-051	2353 059 050-114
65	4326 065 000-052	4328 065 000-054	4326 065 000-050	4327 065 000-051	2353 076 066-114
80	4326 080 000-052	4328 080 000-054	4326 080 000-050	4327 080 000-051	2353 090 081-114
100	4326 100 000-052	4328 100 000-054	4326 100 000-050	4327 100 000-051	2353 109 100-114
125	4326 125 000-052	4328 125 000-054	4326 125 000-050	4327 125 000-051	2353 136 125-114
150	4326 150 000-052	4328 150 000-054	4326 150 000-050	4327 150 000-051	2353 161 150-114
200	-	4328 200 000-054	-	-	2353 211 200-114
1	4326 026 000-052	4328 026 000-054	4326 026 000-050	4327 026 000-051	2353 032 024-114
1½	4326 038 000-052	4328 038 000-054	4326 038 000-050	4327 038 000-051	2353 044 036-114
2	4326 051 000-052	4328 051 000-054	4326 051 000-050	4327 051 000-051	2353 057 049-114
2½	4326 064 000-052	4328 064 000-054	4326 064 000-050	4327 064 000-051	2353 071 061-114
3	4326 076 076-052	4328 076 076-054	4326 076 076-050	4327 076 076-051	2353 083 073-114
4	4326 101 000-052	4328 101 000-054	4326 101 000-050	4327 101 000-051	2353 107 099-114

11 Malfunctions

Malfunction	Cause	Remedy
Valve does not move	<ul style="list-style-type: none"> - Compressed air missing - Electrical controller missing - Actuator defective 	<ul style="list-style-type: none"> - Switch on compressed air - Check and ensure electrical signals - Check and ensure electrical signals
Signals do not come on	<ul style="list-style-type: none"> - Loose cable on pilot valve or initiator - Cable broken - Initiators defective - Pilot valve defective - Electrical supply missing or damaged 	<ul style="list-style-type: none"> - Tighten cable - Replace cable - Replace initiators - Replace pilot valve - Check or remedy
Valve moves too slowly	<ul style="list-style-type: none"> - Compressed air too low - Exhaust hole actuator plugged up 	<ul style="list-style-type: none"> - Increase compressed air - Clear opening
Valve moves unevenly	<ul style="list-style-type: none"> - Compressed air supply too weak - Media pressure too high - Electric signals uneven 	<ul style="list-style-type: none"> - Increase compressed air - Check media pressure and adjust if necessary - Remedy signal flow malfunction
Valve causes excessive mechanical noises	<ul style="list-style-type: none"> - Lubrication missing 	<ul style="list-style-type: none"> - Lubricate seal and guide elements

12 Classification

12.1 Structure of order number

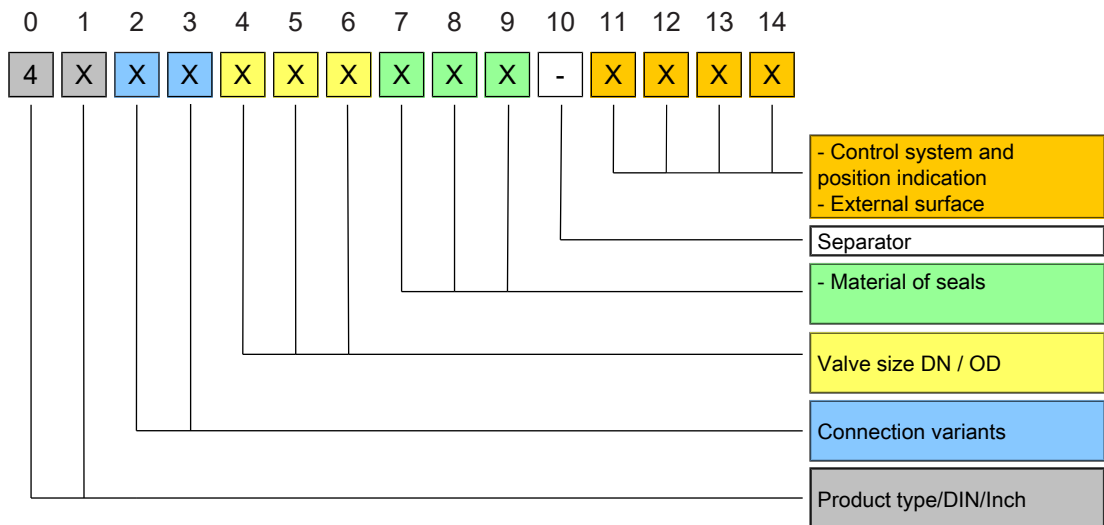

0 - 2 Product type

XXxx xxx xxx-xxxx

0	1	2	3	Designation
4	3	x	x	Butterfly valve/Leakage butterfly valve manual operating
4	5	x	x	Butterfly valve/Leakage butterfly valve pneumatic operating air open- spring close (NC)
4	4	x	x	Butterfly valve/Leakage butterfly valve pneumatic operating air open - air close (DA)

2 - 3 Connection variant

xxXX xxx xxx-xxxx

z.B. Type 4502 = Male flange / Welding flange
oder Type 4510 = Intermediate
(see Valve types [▶ 9])

4 - 6 Valve size DN/OD

xxxx XXX xxx-xxxx

DN	4	5	6	OD	4	5	6
DN 25	0	2	5	OD 1"	0	2	6
DN 40	0	4	0	OD 1 1/2"	0	3	8
DN 50	0	5	0	OD 2 "	0	5	1
DN 65	0	6	5	OD 2 1/2"	0	6	4
DN 80	0	8	0	OD 3 "	0	7	6
DN 100	1	0	0	OD 4 "	1	0	1
DN 125	1	2	5	-			
DN 150	1	5	0	-			
DN 200	2	0	0	-			

7 - 9 Material of sealsxxxx xxx **xxx**-xxxx

Sealing material - in product contact	7	8	9
EPDM	1	3	0
HNBR	4	2	0
Silicone	0	0	0
FKM	1	4	0

10 Separator

xxxx xxx xxx - xxxx

11 - 14 Control system and position indication , External surfacexxxx xxx xxx - **xxxx**

Control system	11	12	13	14
Control head SPS (alte Version)	5	x	x	
Control head ASi-Bus (alte Version)	6	x	x	
Control head KI-Top SPS	K	5	x	x
Control head KI-Top ASi-Bus	K	6	x	x

Position indicator, External surface	11	12	13	14
Position indication external surface AISI304 blanc	0	2	0	
Position indication external surface AISI304 e-polished	0	2	1	
Position indication external surface AISI304 mat finish	0	2	2	
Position indication external surface AISI316L blanc	0	4	0	
Position indication external surface AISI316L e-polished	0	4	1	
Position indication external surface AISI316L mat finish	0	4	2	

13 Appendix

13.1 Declaration of incorporation



Declaration of incorporation

Translation of the original

Manufacturer / authorised representative: Authorised representative: (for compiling technical documents)	KIESELMANN GmbH Paul-Kieselmann-Str. 4-10 75438 Knittlingen Germany Achim Kauselmann Paul-Kieselmann-Str. 4-10 75438 Knittlingen Germany
--	---

<u>Product name</u>	<u>Function</u>
pneum. Lift actuators	Stroke movement
pneum. Rotary actuators	Rotary movement
Ball valves	Media cutoff
Butterfly valves	Media cutoff
Single seat valves	Media cutoff
Flow control valves	Control of liquefied media
Throttle valve	Control of liquefied media
Overflow valve	Definition of fluid pressure
Double seat valve	Media separation
Bellow valves	Sampling of liquids
Sampling valves	Sampling of liquids
Two way valves	Media cutoff
Tankdome fitting	Prevention of overpressure and vacuum, Tank cleaning
Safety valve	Prevention of overpressure

The manufacturer hereby states that the above product is considered as an incomplete machine in the sense defined in the Directive 2006/42/EC on Machinery. The above product is exclusively intended to be installed into a machine or an incomplete machine. The said product does not yet conform to all the relevant requirements defined in the Directive on Machinery referred to above for this reason.

The specific technical documents listed in Appendix VII, Part B, have been prepared. The Authorized Agent empowered to compile technical documents may submit the relevant documents if such a request has been properly justified.

Commissioning of an incomplete machine must not only be carried out if it has been determined that the respective machine into which the incomplete machine is to be installed conforms to the regulations set out in the Directive on Machinery referred to above.

The above product conforms to the requirements of the directives and harmonized standards specified below:

- Directive 2014/68/EU
- DIN EN ISO 12100 Safety of machinery

Knittlingen, 21.07.2017

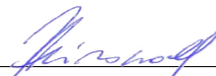

i.V. Uwe Heisswolf
Head of Development