

# Incremental encoders

<b>Standard optical</b>	<b>Sendix 5000 / 5020 (shaft / hollow shaft)</b>	<b>Push-Pull / RS422</b>
-------------------------	--	--------------------------



Due to their sturdy bearing construction in Safety-Lock™ Design, the Sendix 5000 and 5020 offer high resistance against vibration and installation errors.

The rugged housing, high protection level of up to IP67, as well as the wide temperature range of -40°C up to +85°C, make this product range the perfect encoder for all applications.



Incremental encoders

Safety-Lock™	High rotational speed	Temperature range	High protection level	High shaft load capacity	Shock / vibration resistant	Magnetic field proof	Short-circuit proof	Reverse polarity protection	Optical sensor	Surface protection salt spray-tested optional

## Robust performance

- Increased resistance against vibrations and tolerance of installation errors, elimination of machine downtime and repairs thanks to sturdy bearing construction in "Safety-Lock™ Design".
- Ensures highest safety against field breakdowns and is thus suitable also for outside use thanks to its resistant die-cast housing and protection up to IP67.
- Wide temperature range, -40°C ... +85°C.

## Many variants

- Suitable connection variant for every specific case: cable connection, M12, M23 and MIL connector.
- Reliable mounting in a wide variety of installation situations: comprehensive and proven fixing possibilities.
- Compatible with all US and European standards.
- Max. 5000 pulses per revolution.

## Order code

**8.5000** . **XXXX** . **XXXX**  
 Type                      a    b    c    d                      e

If for each parameter of an encoder the underlined preferred option is selected, then the delivery time will be 10 working days for a maximum of 10 pieces.  
 Qts. up to 50 pcs. of these types generally have a delivery time of 15 working days.



### a Flange

- 5 = synchro flange, IP67    ø 50.8 mm [2"]
  - 6 = synchro flange, IP65    ø 50.8 mm [2"]
  - 7 = clamping flange, IP67    ø 58 mm [2.28"]
  - 8 = clamping flange, IP65    ø 58 mm [2.28"]**
  - A = synchro flange, IP67    ø 58 mm [2.28"]
  - B = synchro flange, IP65    ø 58 mm [2.28"]**
  - C = square flange, IP67    □ 63.5 mm [2.5"]
  - D = square flange, IP65    □ 63.5 mm [2.5"]
  - G = euro flange, IP67        ø 115 mm [4.53"]<sup>2)</sup>
- 
- 1 = servo flange, IP67        ø 50.8 mm [2"]<sup>1)</sup>
  - 2 = servo flange, IP65        ø 50.8 mm [2"]<sup>1)</sup>
  - 3 = square flange, IP67        □ 50.8 mm [2"]<sup>1)</sup>
  - 4 = square flange, IP65        □ 50.8 mm [2"]<sup>1)</sup>
  - E = servo flange, IP67        ø 63.5 mm [2.5"]<sup>1)</sup>
  - F = servo flange, IP65        ø 63.5 mm [2.5"]<sup>1)</sup>

### b Shaft (ø x L), with flat

- 1 = ø 6 x 10 mm [0.24 x 0.39"]**    2 = ø 1/4 x 5/8"
- 6 = ø 8 x 15 mm [0.32 x 0.59"]    4 = ø 3/8 x 5/8"
- 3 = ø 10 x 20 mm [0.39 x 0.79"]**
- B = ø 11 x 33 mm [0.43 x 1.30"],  
with feather key shaft slot<sup>3)</sup>
- 5 = ø 12 x 20 mm [0.47 x 0.79"]
- 7 = ø 1/4 x 7/8"<sup>1)</sup>
- 8 = ø 3/8 x 7/8"<sup>1)</sup>

### c Output circuit / power supply

- 4 = RS422 (with inverted signal) / 5 V DC**
- 1 = RS422 (with inverted signal) / 5 ... 30 V DC
- 2 = Push-Pull (7272 compatible with inverted signal) / 5 ... 30 V DC
- 5 = Push-Pull (with inverted signal) / 10 ... 30 V DC**
- 3 = Open collector (with inverted signal) / 5 ... 30 V DC<sup>1)</sup>
- 8 = Push-Pull (7272 with inverted signal),  
without capacitor / 5 ... 30 V DC<sup>1)</sup>

### d Type of connection

- 1 = axial cable, 1 m [3.28'] PVC
  - A = axial cable, special length PVC \*)
  - 2 = radial cable, 1 m [3.28'] PVC**
  - B = radial cable, special length PVC \*)
  - 3 = axial M12 connector, 8-pin
  - 4 = radial M12 connector, 8-pin**
  - 7 = axial M23 connector, 12-pin
  - 8 = radial M23 connector, 12-pin**
  - Y = radial MIL connector, 10-pin
  - W = radial MIL connector, 7-pin
  - 9 = radial MIL connector, 6-pin<sup>1)</sup>
- \*) Available special lengths (connection types A, B):  
 2, 3, 5, 8, 10, 15 m [6.56, 9.84, 16.40, 26.25, 32.80, 49.21']  
 order code expansion: .XXXX = length in dm  
 ex.: 8.5000.814A.1024.0030 (for cable length 3 m)

### e Pulse rate

- 1, 5, 10, 12, 36, 100, 200, 250, 256,  
**360, 400, 500, 512, 600, 800, 1000,**  
**1024, 1200, 2000, 2048, 2500, 3600,**  
**4096, 5000**  
(e.g. 100 pulses => 0100)
- Stock types*
- 8.5000.8354.1024
- 8.5000.8354.5000
- 8.5000.8358.0200
- 8.5000.8358.0360
- 8.5000.8358.0500
- 8.5000.8358.1000
- 8.5000.8358.5000
- 8.5000.B157.1024
- Optional on request*
- other pulse rates
- Ex 2/22
- surface protection salt spray tested

1) US version.

2) Only in conjunction with shaft type B.

3) Only in conjunction with flange type G.



# Incremental encoders

<b>Standard optical</b>	<b>Sendix 5000 / 5020 (shaft / hollow shaft)</b>	<b>Push-Pull / RS422</b>
-------------------------	--	--------------------------

<b>Order code</b> <b>Hollow shaft</b>	<table border="1" style="width: 100%; border-collapse: collapse;"> <tr> <td style="text-align: center; padding: 2px;"><b>8.5020</b></td> <td style="text-align: center; padding: 2px;">.</td> <td style="text-align: center; padding: 2px;"><b>X</b></td> <td style="text-align: center; padding: 2px;"><b>X</b></td> <td style="text-align: center; padding: 2px;"><b>X</b></td> <td style="text-align: center; padding: 2px;"><b>X</b></td> <td style="text-align: center; padding: 2px;">.</td> <td style="text-align: center; padding: 2px;"><b>XXXX</b></td> </tr> <tr> <td style="text-align: center; font-size: 8px;">Type</td> <td></td> <td style="text-align: center; font-size: 8px;">a</td> <td style="text-align: center; font-size: 8px;">b</td> <td style="text-align: center; font-size: 8px;">c</td> <td style="text-align: center; font-size: 8px;">d</td> <td></td> <td style="text-align: center; font-size: 8px;">e</td> </tr> </table>	<b>8.5020</b>	.	<b>X</b>	<b>X</b>	<b>X</b>	<b>X</b>	.	<b>XXXX</b>	Type		a	b	c	d		e	<p>If for each parameter of an encoder the <u>underlined preferred option</u> is selected, then the delivery time will be 10 working days for a maximum of 10 pieces. Qts. up to 50 pcs. of these types generally have a delivery time of 15 working days.</p> <div style="text-align: right; border: 1px solid black; border-radius: 50%; padding: 2px; width: 40px; float: right;">10 by 10</div> <div style="clear: both;"></div> <table style="width: 100%; border: none;"> <tr> <td style="width: 33%; vertical-align: top; padding: 5px;"> <p><b>a Flange</b></p> <p>1 = with spring element, long, IP67  <u>2 = with spring element, long, IP65</u>            3 = with fastening arm, long, IP67            4 = with fastening arm, long, IP65            7 = with stator coupling, IP67 <math>\varnothing</math> 65 mm [2.56"]  <u>8 = with stator coupling, IP65 <math>\varnothing</math> 65 mm [2.56"]</u>            C = with stator coupling, IP67 <math>\varnothing</math> 63 mm [2.48"]  <u>D = with stator coupling, IP65 <math>\varnothing</math> 63 mm [2.48"]</u></p> <p>5 = with stator coupling, IP67 <math>\varnothing</math> 57.2 mm [2.25"]<sup>1)</sup>            6 = with stator coupling, IP65 <math>\varnothing</math> 57.2 mm [2.25"]<sup>1)</sup></p> <p><b>b Hollow shaft</b></p> <table style="width: 100%; border: none;"> <tr> <td>1 = <math>\varnothing</math> 6 mm [0.24"]</td> <td>2 = <math>\varnothing</math> 1/4"</td> </tr> <tr> <td><u>9 = <math>\varnothing</math> 8 mm [0.32"]</u></td> <td>4 = <math>\varnothing</math> 3/8"</td> </tr> <tr> <td><u>3 = <math>\varnothing</math> 10 mm [0.39"]</u></td> <td>6 = <math>\varnothing</math> 1/2"</td> </tr> <tr> <td><u>5 = <math>\varnothing</math> 12 mm [0.47"]</u></td> <td>7 = <math>\varnothing</math> 5/8"</td> </tr> <tr> <td>A = <math>\varnothing</math> 14 mm [0.55"]</td> <td></td> </tr> <tr> <td><u>8 = <math>\varnothing</math> 15 mm [0.59"]</u></td> <td></td> </tr> </table> </td> <td style="width: 33%; vertical-align: top; padding: 5px;"> <p><b>c Output circuit / power supply</b></p> <p><u>4 = RS422 (with inverted signal) / 5 V DC</u>            1 = RS422 (with inverted signal) / 5 ... 30 V DC            2 = Push-Pull (7272 compatible with inverted signal) / 5 ... 30 V DC  <u>5 = Push-Pull (with inverted signal) / 10 ... 30 V DC</u></p> <p>3 = open collector (with inverted signal) / 5 ... 30 V DC<sup>1)</sup>            8 = Push-Pull (7272 with inverted signal), without capacitor / 5 ... 30 V DC<sup>1)</sup></p> <p><b>d Type of connection</b></p> <p>1 = radial cable, 1 m [3.28'] PVC            A = radial cable, special length PVC *)  <u>2 = radial M12 connector, 8-pin</u>  <u>4 = radial M23 connector, 12-pin</u>            7 = radial MIL connector, 10-pin  <u>E = tangential cable, 1 m [3.28'] PVC</u>            F = tangential cable, special length PVC *)            H = tangential cable, 0.3 m [0.98'] PVC, including M12 connector for central fastening</p> <p>*) Available special lengths (connection types A, F):            2, 3, 5, 8, 10, 15 m [6.56, 9.84, 16.40, 26.25, 32.80, 49.21']            order code expansion .XXXX = length in dm            ex.: 8.5020.234A.1024.0030 (for cable length 3 m)</p> </td> <td style="width: 33%; vertical-align: top; padding: 5px;"> <p><b>e Pulse rate</b></p> <p>1, 5, 10, 12, 36, 100, 200, 250, 256,  <u>360, 400, 500, 512, 600, 800, 1000,</u>  <u>1024, 1200, 2000, 2048, 2500, 3600,</u>  <u>4096, 5000</u>            (e.g. 100 pulses =&gt; 0100)</p> <p><i>Stock types</i></p> <p>8.5020.2351.1000            8.5020.2351.2500            8.5020.8552.1024</p> <p><i>Optional on request</i></p> <ul style="list-style-type: none"> <li>- other pulse rates</li> <li>- Ex 2/22</li> <li>(not for type of connection E, F, H)</li> <li>- surface protection salt spray tested</li> </ul> </td> </tr> </table>	<p><b>a Flange</b></p> <p>1 = with spring element, long, IP67  <u>2 = with spring element, long, IP65</u>            3 = with fastening arm, long, IP67            4 = with fastening arm, long, IP65            7 = with stator coupling, IP67 <math>\varnothing</math> 65 mm [2.56"]  <u>8 = with stator coupling, IP65 <math>\varnothing</math> 65 mm [2.56"]</u>            C = with stator coupling, IP67 <math>\varnothing</math> 63 mm [2.48"]  <u>D = with stator coupling, IP65 <math>\varnothing</math> 63 mm [2.48"]</u></p> <p>5 = with stator coupling, IP67 <math>\varnothing</math> 57.2 mm [2.25"]<sup>1)</sup>            6 = with stator coupling, IP65 <math>\varnothing</math> 57.2 mm [2.25"]<sup>1)</sup></p> <p><b>b Hollow shaft</b></p> <table style="width: 100%; border: none;"> <tr> <td>1 = <math>\varnothing</math> 6 mm [0.24"]</td> <td>2 = <math>\varnothing</math> 1/4"</td> </tr> <tr> <td><u>9 = <math>\varnothing</math> 8 mm [0.32"]</u></td> <td>4 = <math>\varnothing</math> 3/8"</td> </tr> <tr> <td><u>3 = <math>\varnothing</math> 10 mm [0.39"]</u></td> <td>6 = <math>\varnothing</math> 1/2"</td> </tr> <tr> <td><u>5 = <math>\varnothing</math> 12 mm [0.47"]</u></td> <td>7 = <math>\varnothing</math> 5/8"</td> </tr> <tr> <td>A = <math>\varnothing</math> 14 mm [0.55"]</td> <td></td> </tr> <tr> <td><u>8 = <math>\varnothing</math> 15 mm [0.59"]</u></td> <td></td> </tr> </table>	1 = $\varnothing$ 6 mm [0.24"]	2 = $\varnothing$ 1/4"	<u>9 = <math>\varnothing</math> 8 mm [0.32"]</u>	4 = $\varnothing$ 3/8"	<u>3 = <math>\varnothing</math> 10 mm [0.39"]</u>	6 = $\varnothing$ 1/2"	<u>5 = <math>\varnothing</math> 12 mm [0.47"]</u>	7 = $\varnothing$ 5/8"	A = $\varnothing$ 14 mm [0.55"]		<u>8 = <math>\varnothing</math> 15 mm [0.59"]</u>		<p><b>c Output circuit / power supply</b></p> <p><u>4 = RS422 (with inverted signal) / 5 V DC</u>            1 = RS422 (with inverted signal) / 5 ... 30 V DC            2 = Push-Pull (7272 compatible with inverted signal) / 5 ... 30 V DC  <u>5 = Push-Pull (with inverted signal) / 10 ... 30 V DC</u></p> <p>3 = open collector (with inverted signal) / 5 ... 30 V DC<sup>1)</sup>            8 = Push-Pull (7272 with inverted signal), without capacitor / 5 ... 30 V DC<sup>1)</sup></p> <p><b>d Type of connection</b></p> <p>1 = radial cable, 1 m [3.28'] PVC            A = radial cable, special length PVC *)  <u>2 = radial M12 connector, 8-pin</u>  <u>4 = radial M23 connector, 12-pin</u>            7 = radial MIL connector, 10-pin  <u>E = tangential cable, 1 m [3.28'] PVC</u>            F = tangential cable, special length PVC *)            H = tangential cable, 0.3 m [0.98'] PVC, including M12 connector for central fastening</p> <p>*) Available special lengths (connection types A, F):            2, 3, 5, 8, 10, 15 m [6.56, 9.84, 16.40, 26.25, 32.80, 49.21']            order code expansion .XXXX = length in dm            ex.: 8.5020.234A.1024.0030 (for cable length 3 m)</p>	<p><b>e Pulse rate</b></p> <p>1, 5, 10, 12, 36, 100, 200, 250, 256,  <u>360, 400, 500, 512, 600, 800, 1000,</u>  <u>1024, 1200, 2000, 2048, 2500, 3600,</u>  <u>4096, 5000</u>            (e.g. 100 pulses =&gt; 0100)</p> <p><i>Stock types</i></p> <p>8.5020.2351.1000            8.5020.2351.2500            8.5020.8552.1024</p> <p><i>Optional on request</i></p> <ul style="list-style-type: none"> <li>- other pulse rates</li> <li>- Ex 2/22</li> <li>(not for type of connection E, F, H)</li> <li>- surface protection salt spray tested</li> </ul>
<b>8.5020</b>	.	<b>X</b>	<b>X</b>	<b>X</b>	<b>X</b>	.	<b>XXXX</b>																										
Type		a	b	c	d		e																										
<p><b>a Flange</b></p> <p>1 = with spring element, long, IP67  <u>2 = with spring element, long, IP65</u>            3 = with fastening arm, long, IP67            4 = with fastening arm, long, IP65            7 = with stator coupling, IP67 <math>\varnothing</math> 65 mm [2.56"]  <u>8 = with stator coupling, IP65 <math>\varnothing</math> 65 mm [2.56"]</u>            C = with stator coupling, IP67 <math>\varnothing</math> 63 mm [2.48"]  <u>D = with stator coupling, IP65 <math>\varnothing</math> 63 mm [2.48"]</u></p> <p>5 = with stator coupling, IP67 <math>\varnothing</math> 57.2 mm [2.25"]<sup>1)</sup>            6 = with stator coupling, IP65 <math>\varnothing</math> 57.2 mm [2.25"]<sup>1)</sup></p> <p><b>b Hollow shaft</b></p> <table style="width: 100%; border: none;"> <tr> <td>1 = <math>\varnothing</math> 6 mm [0.24"]</td> <td>2 = <math>\varnothing</math> 1/4"</td> </tr> <tr> <td><u>9 = <math>\varnothing</math> 8 mm [0.32"]</u></td> <td>4 = <math>\varnothing</math> 3/8"</td> </tr> <tr> <td><u>3 = <math>\varnothing</math> 10 mm [0.39"]</u></td> <td>6 = <math>\varnothing</math> 1/2"</td> </tr> <tr> <td><u>5 = <math>\varnothing</math> 12 mm [0.47"]</u></td> <td>7 = <math>\varnothing</math> 5/8"</td> </tr> <tr> <td>A = <math>\varnothing</math> 14 mm [0.55"]</td> <td></td> </tr> <tr> <td><u>8 = <math>\varnothing</math> 15 mm [0.59"]</u></td> <td></td> </tr> </table>	1 = $\varnothing$ 6 mm [0.24"]	2 = $\varnothing$ 1/4"	<u>9 = <math>\varnothing</math> 8 mm [0.32"]</u>	4 = $\varnothing$ 3/8"	<u>3 = <math>\varnothing</math> 10 mm [0.39"]</u>	6 = $\varnothing$ 1/2"	<u>5 = <math>\varnothing</math> 12 mm [0.47"]</u>	7 = $\varnothing$ 5/8"	A = $\varnothing$ 14 mm [0.55"]		<u>8 = <math>\varnothing</math> 15 mm [0.59"]</u>		<p><b>c Output circuit / power supply</b></p> <p><u>4 = RS422 (with inverted signal) / 5 V DC</u>            1 = RS422 (with inverted signal) / 5 ... 30 V DC            2 = Push-Pull (7272 compatible with inverted signal) / 5 ... 30 V DC  <u>5 = Push-Pull (with inverted signal) / 10 ... 30 V DC</u></p> <p>3 = open collector (with inverted signal) / 5 ... 30 V DC<sup>1)</sup>            8 = Push-Pull (7272 with inverted signal), without capacitor / 5 ... 30 V DC<sup>1)</sup></p> <p><b>d Type of connection</b></p> <p>1 = radial cable, 1 m [3.28'] PVC            A = radial cable, special length PVC *)  <u>2 = radial M12 connector, 8-pin</u>  <u>4 = radial M23 connector, 12-pin</u>            7 = radial MIL connector, 10-pin  <u>E = tangential cable, 1 m [3.28'] PVC</u>            F = tangential cable, special length PVC *)            H = tangential cable, 0.3 m [0.98'] PVC, including M12 connector for central fastening</p> <p>*) Available special lengths (connection types A, F):            2, 3, 5, 8, 10, 15 m [6.56, 9.84, 16.40, 26.25, 32.80, 49.21']            order code expansion .XXXX = length in dm            ex.: 8.5020.234A.1024.0030 (for cable length 3 m)</p>	<p><b>e Pulse rate</b></p> <p>1, 5, 10, 12, 36, 100, 200, 250, 256,  <u>360, 400, 500, 512, 600, 800, 1000,</u>  <u>1024, 1200, 2000, 2048, 2500, 3600,</u>  <u>4096, 5000</u>            (e.g. 100 pulses =&gt; 0100)</p> <p><i>Stock types</i></p> <p>8.5020.2351.1000            8.5020.2351.2500            8.5020.8552.1024</p> <p><i>Optional on request</i></p> <ul style="list-style-type: none"> <li>- other pulse rates</li> <li>- Ex 2/22</li> <li>(not for type of connection E, F, H)</li> <li>- surface protection salt spray tested</li> </ul>																			
1 = $\varnothing$ 6 mm [0.24"]	2 = $\varnothing$ 1/4"																																
<u>9 = <math>\varnothing</math> 8 mm [0.32"]</u>	4 = $\varnothing$ 3/8"																																
<u>3 = <math>\varnothing</math> 10 mm [0.39"]</u>	6 = $\varnothing$ 1/2"																																
<u>5 = <math>\varnothing</math> 12 mm [0.47"]</u>	7 = $\varnothing$ 5/8"																																
A = $\varnothing$ 14 mm [0.55"]																																	
<u>8 = <math>\varnothing</math> 15 mm [0.59"]</u>																																	

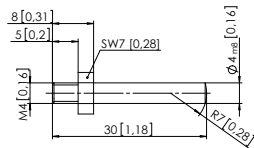
Mounting accessory for shaft encoders	Order no.
<b>Coupling</b>	bellows coupling $\varnothing$ 19 mm [0.75"] for shaft 6 mm [0.24"] <span style="float: right;"><b>8.0000.1102.0606</b></span>
	bellows coupling $\varnothing$ 19 mm [0.75"] for shaft 10 mm [0.39"] <span style="float: right;"><b>8.0000.1102.1010</b></span>

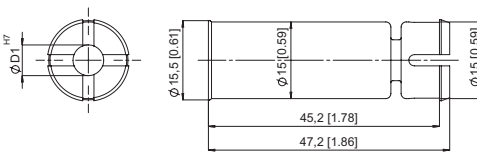
Mounting accessory for hollow shaft encoders	Order no.
<b>Cylindrical pin, long</b> for torque stops <div style="display: flex; align-items: center; margin-top: 10px;">  <div style="margin-left: 10px;">with fixing thread</div> </div>	<b>8.0010.4700.0000</b>

Isolation / adapter inserts for hollow shaft encoders	Order no.																								
<p><b>Thermal and electrical isolation of the encoders</b>            (Temperature range -40 ... +115°C [-40°F ... +239°F])</p> <p>Isolation inserts prevent currents from passing through the encoder bearings. These currents can occur when using inverter controlled three-phase or AC vector motors and considerably shorten the service life of the encoder bearings. In addition the encoder is thermally isolated as the plastic does not transfer the heat to the encoder.</p> <div style="display: flex; align-items: center; margin-top: 10px;">  <div style="margin-left: 20px;">  <p><b>Tip:</b> By using these adapter inserts you can achieve six different hollow shaft diameters, all on the basis of the encoder 8.5020.X8XX.XXXX.</p> </div> </div>	<table style="width: 100%; border: none;"> <tr> <td style="width: 30%;"></td> <td style="text-align: right;">D1</td> <td style="text-align: right;">Isolation insert</td> </tr> <tr> <td>6 mm [0.24"]</td> <td></td> <td style="text-align: right;"><b>8.0010.4021.0000</b></td> </tr> <tr> <td>8 mm [0.32"]</td> <td></td> <td style="text-align: right;"><b>8.0010.4020.0000</b></td> </tr> <tr> <td>10 mm [0.39"]</td> <td></td> <td style="text-align: right;"><b>8.0010.4023.0000</b></td> </tr> <tr> <td>12 mm [0.47"]</td> <td></td> <td style="text-align: right;"><b>8.0010.4025.0000</b></td> </tr> <tr> <td>1/4"</td> <td></td> <td style="text-align: right;"><b>8.0010.4022.0000</b></td> </tr> <tr> <td>3/8"</td> <td></td> <td style="text-align: right;"><b>8.0010.4024.0000</b></td> </tr> <tr> <td>1/2"</td> <td></td> <td style="text-align: right;"><b>8.0010.4026.0000</b></td> </tr> </table>		D1	Isolation insert	6 mm [0.24"]		<b>8.0010.4021.0000</b>	8 mm [0.32"]		<b>8.0010.4020.0000</b>	10 mm [0.39"]		<b>8.0010.4023.0000</b>	12 mm [0.47"]		<b>8.0010.4025.0000</b>	1/4"		<b>8.0010.4022.0000</b>	3/8"		<b>8.0010.4024.0000</b>	1/2"		<b>8.0010.4026.0000</b>
	D1	Isolation insert																							
6 mm [0.24"]		<b>8.0010.4021.0000</b>																							
8 mm [0.32"]		<b>8.0010.4020.0000</b>																							
10 mm [0.39"]		<b>8.0010.4023.0000</b>																							
12 mm [0.47"]		<b>8.0010.4025.0000</b>																							
1/4"		<b>8.0010.4022.0000</b>																							
3/8"		<b>8.0010.4024.0000</b>																							
1/2"		<b>8.0010.4026.0000</b>																							

1) US version.

# Incremental encoders

Standard optical	Sendix 5000 / 5020 (shaft / hollow shaft)	Push-Pull / RS422
<b>Connection technology</b>		Order no.
<b>Connector, self-assembly (straight)</b>	M12 female connector with coupling nut	<b>05.CMB 8181-0</b>
	M23 female connector with coupling nut	<b>8.0000.5012.0000</b>
	MIL female connector with coupling nut, 10-pin	<b>8.0000.5062.0000</b>
<b>Cordset, pre-assembled</b>	M12 female connector with coupling nut, 2 m [6.56'] PVC cable	<b>05.00.6041.8211.002M</b>
	M23 female connector with coupling nut, 2 m [6.56'] PVC cable	<b>8.0000.6201.0002</b>

Further accessories can be found in the accessories section or in the accessories area of our website at: [www.kuebler.com/accessories](http://www.kuebler.com/accessories).  
Additional connectors can be found in the connection technology section or in the connection technology area of our website at: [www.kuebler.com/connection\\_technology](http://www.kuebler.com/connection_technology).

Technical data					
<b>Mechanical characteristics</b>					
<b>Maximum speed</b>	<table border="0"> <tr> <td>IP65</td> <td>12000 min<sup>-1</sup> 6000 min<sup>-1</sup> (continuous)</td> </tr> <tr> <td>IP67</td> <td>6000 min<sup>-1</sup> 3000 min<sup>-1</sup> (continuous)</td> </tr> </table>	IP65	12000 min <sup>-1</sup> 6000 min <sup>-1</sup> (continuous)	IP67	6000 min <sup>-1</sup> 3000 min <sup>-1</sup> (continuous)
IP65	12000 min <sup>-1</sup> 6000 min <sup>-1</sup> (continuous)				
IP67	6000 min <sup>-1</sup> 3000 min <sup>-1</sup> (continuous)				
<b>Mass moment of inertia</b>	<table border="0"> <tr> <td>shaft version</td> <td>approx. 1.8 x 10<sup>-6</sup> kgm<sup>2</sup></td> </tr> <tr> <td>hollow shaft version</td> <td>approx. 6 x 10<sup>-6</sup> kgm<sup>2</sup></td> </tr> </table>	shaft version	approx. 1.8 x 10 <sup>-6</sup> kgm <sup>2</sup>	hollow shaft version	approx. 6 x 10 <sup>-6</sup> kgm <sup>2</sup>
shaft version	approx. 1.8 x 10 <sup>-6</sup> kgm <sup>2</sup>				
hollow shaft version	approx. 6 x 10 <sup>-6</sup> kgm <sup>2</sup>				
<b>Starting torque at 20°C [68°F]</b>	<table border="0"> <tr> <td>IP65</td> <td>&lt; 0.01 Nm</td> </tr> <tr> <td>IP67</td> <td>&lt; 0.05 Nm</td> </tr> </table>	IP65	< 0.01 Nm	IP67	< 0.05 Nm
IP65	< 0.01 Nm				
IP67	< 0.05 Nm				
<b>Shaft load capacity</b>	<table border="0"> <tr> <td>radial</td> <td>80 N</td> </tr> <tr> <td>axial</td> <td>40 N</td> </tr> </table>	radial	80 N	axial	40 N
radial	80 N				
axial	40 N				
<b>Weight</b>	approx. 0.4 kg [14.11 oz]				
<b>Protection</b> acc. to EN 60529	<table border="0"> <tr> <td>without shaft seal</td> <td>IP65</td> </tr> <tr> <td>with shaft seal</td> <td>IP67</td> </tr> </table>	without shaft seal	IP65	with shaft seal	IP67
without shaft seal	IP65				
with shaft seal	IP67				
<b>Working temperature range</b>	-40°C <sup>1)</sup> ... +85°C [-40°F <sup>1)</sup> ... +185°F]				
<b>Material</b>	shaft stainless steel				
<b>Shock resistance</b> acc. to EN 60068-2-27	2500 m/s <sup>2</sup> , 6 ms				
<b>Vibration resistance</b> acc. to EN 60068-2-6	100 m/s <sup>2</sup> , 10 ... 2000 Hz				

Electrical characteristics						
Output circuit	RS422 (TTL compatible)	RS422 (TTL compatible)	Push-Pull	Push-Pull (7272 compatible)	Push-Pull (7272, without capacitor)	Open collector (7273)
Ordercode	<b>1</b>	<b>4</b>	<b>5</b>	<b>2</b>	<b>8</b>	<b>3</b>
<b>Power supply</b>	5 ... 30 V DC	5 V DC (±5 %)	10 ... 30 V DC	5 ... 30 V DC	5 ... 30 V DC	5 ... 30 V DC
<b>Power consumption (no load)</b>	typ. 40 mA max. 90 mA	typ. 40 mA max. 90 mA	typ. 50 mA max. 100 mA	typ. 50 mA max. 100 mA	typ. 50 mA max. 100 mA	100 mA
<b>Permissible load / channel</b>	max. +/- 20 mA	max. +/- 20 mA	max. +/- 20 mA	max. +/- 20 mA	max. +/- 20 mA	+/- 20 mA sink at 30 V DC
<b>Pulse frequency</b>	max. 300 kHz	max. 300 kHz	max. 300 kHz	max. 300 kHz <sup>2)</sup>	max. 300 kHz	max. 300 kHz
<b>Signal level</b>	HIGH min. 2.5 V LOW max. 0.5 V	min. 2.5 V max. 0.5 V	min +V - 1.0 V max. 0.5 V	min. +V - 2.0 V max. 0.5 V	min. +V - 2.0 V max. 0.5 V	min. +V - 2.0 V max. 0.5 V
<b>Rising edge time t<sub>r</sub></b>	max. 200 ns	max. 200 ns	max. 1 μs	max. 1 μs	max. 1 μs	max. 1 μs
<b>Falling edge time t<sub>f</sub></b>	max. 200 ns	max. 200 ns	max. 1 μs	max. 1 μs	max. 1 μs	max. 1 μs
<b>Short circuit proof outputs<sup>3)</sup></b>	yes <sup>4)</sup>	yes <sup>4)</sup>	yes	yes	yes <sup>4)</sup>	yes
<b>Reverse polarity protection of the power supply</b>	yes	no	yes	no	no	no
<b>UL approval</b>	file 224618					
<b>CE compliant</b> acc. to	EMC guideline 2004/108/EC RoHS guideline 2011/65/EU					

1) With connector: -40°C [-40°F], cable fixed: -30°C [-22°F], cable moved: -20°C [-4°F].  
2) Max. recommended cable length 30 m [98.43'].  
3) If power supply correctly applied.  
4) Only one channel allowed to be shorted-out:  
at +V= 5 V DC, short-circuit to channel, 0 V, or +V is permitted.  
at +V= 5 ... 30 V DC, short-circuit to channel or 0 V is permitted.

# Incremental encoders

**Standard optical**

**Sendix 5000 / 5020 (shaft / hollow shaft)**

**Push-Pull / RS422**

## Terminal assignment

Output circuit	Type of connection	Cable (isolate unused wires individually before initial start-up)												
1, 2, 3, 4, 5, 8	5000: 1, 2, A, B	Signal:	0 V	+V	0 Vsens	+Vsens	A	$\bar{A}$	B	$\bar{B}$	0	$\bar{0}$	$\perp$	
	5020: 1, A, E, F	Cable colour:	WH	BN	GY PK	RD BU	GN	YE	GY	PK	BU	RD	shield	
1, 2, 3, 4, 5, 8	5000: 3, 4 5020: 2, H <sup>2)</sup>	M12 connector, 8-pin												
		Signal:	0 V	+V	0 Vsens	+Vsens	A	$\bar{A}$	B	$\bar{B}$	0	$\bar{0}$	$\perp$	
		Pin:	1	2			3	4	5	6	7	8	PH <sup>1)</sup>	
1, 2, 3, 4, 5, 8	5000: 7, 8 5020: 4	M23 connector, 12-pin												
		Signal:	0 V	+V	0 Vsens	+Vsens	A	$\bar{A}$	B	$\bar{B}$	0	$\bar{0}$	$\perp$	
		Pin:	10	12	11	2	5	6	8	1	3	4	PH <sup>1)</sup>	
1, 2, 3, 4, 5, 8	5000: Y 5020: 7	MIL connector, 10-pin												
		Signal:	0 V	+V	0 Vsens	+Vsens	A	$\bar{A}$	B	$\bar{B}$	0	$\bar{0}$	$\perp$	
		Pin:	F	D		E	A	G	B	H	C	I	J	
1, 3, 4, 5, 8	5000: W	MIL connector, 7-pin												
		Signal:	0 V	+V	0 Vsens	+Vsens	A	$\bar{A}$	B	$\bar{B}$	0	$\bar{0}$	$\perp$	
		Pin:	F	D		E	A		B		C		G	
1, 3, 4, 5, 8	5000: 9	MIL connector, 6-pin												
		Signal:	0 V	+V	0 Vsens	+Vsens	A	$\bar{A}$	B	$\bar{B}$	0	$\bar{0}$	$\perp$	
		Pin:	A	B			E		D		C			

- +V: Encoder power supply +V DC
- 0 V: Encoder power supply ground GND (0 V)
- 0 Vsens / +Vsens: Using the sensor outputs of the encoder, the voltage present can be measured and if necessary increased accordingly.
- A,  $\bar{A}$ : Incremental output channel A
- B,  $\bar{B}$ : Incremental output channel B
- 0,  $\bar{0}$ : Reference signal
- PH  $\perp$ : Plug connector housing (shield)

## Top view of mating side, male contact base

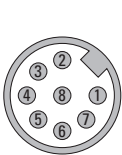

M12 connector, 8-pin

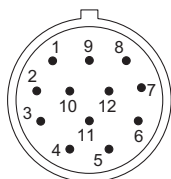

M23 connector, 12-pin

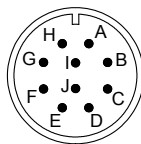

MIL connector, 10-pin

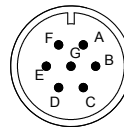

MIL connector, 7-pin

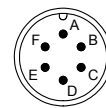

MIL connector, 6-pin

1) PH = shield is attached to connector housing.  
2) With type of connection H shield is not attached to connector housing.

# Incremental encoders

<b>Standard optical</b>	<b>Sendix 5000 / 5020 (shaft / hollow shaft)</b>	<b>Push-Pull / RS422</b>
-------------------------	--	--------------------------

## Dimensions shaft version

Dimensions in mm [inch]

### Synchro flange, ø 50.8 [2] Flange type 5 and 6

1 M3, 6 [0.24] deep

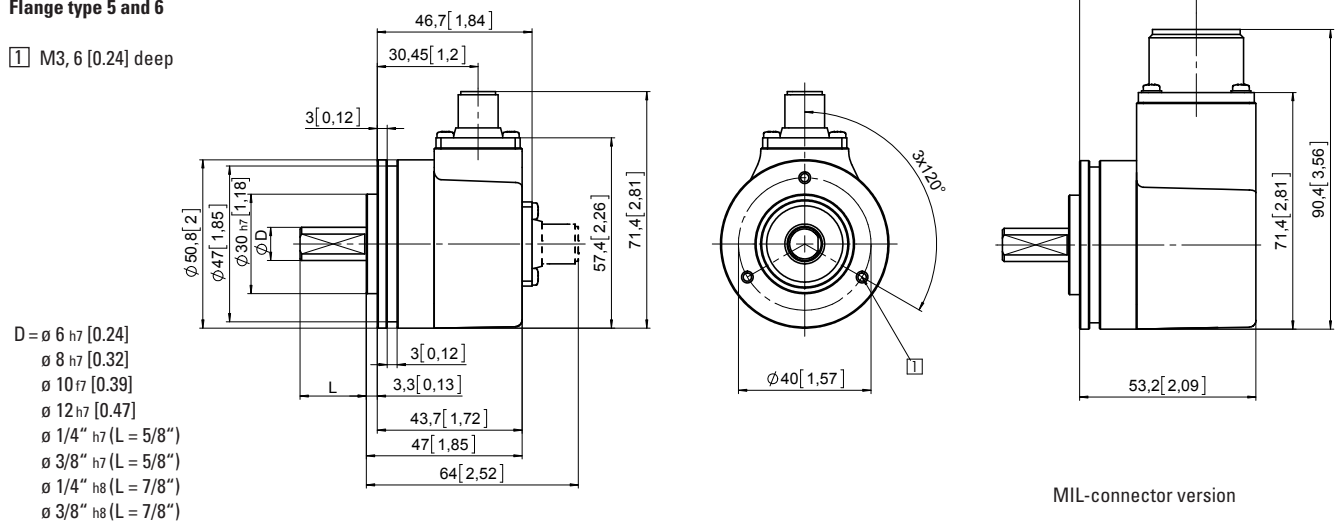

- D = ø 6 h7 [0.24]  
 ø 8 h7 [0.32]  
 ø 10 f7 [0.39]  
 ø 12 h7 [0.47]  
 ø 1/4" h7 (L = 5/8")  
 ø 3/8" h7 (L = 5/8")  
 ø 1/4" h8 (L = 7/8")  
 ø 3/8" h8 (L = 7/8")

MIL-connector version

### Clamping flange, ø 58 [2.28] Flange type 7 and 8

1 M3, 6 [0.24] deep

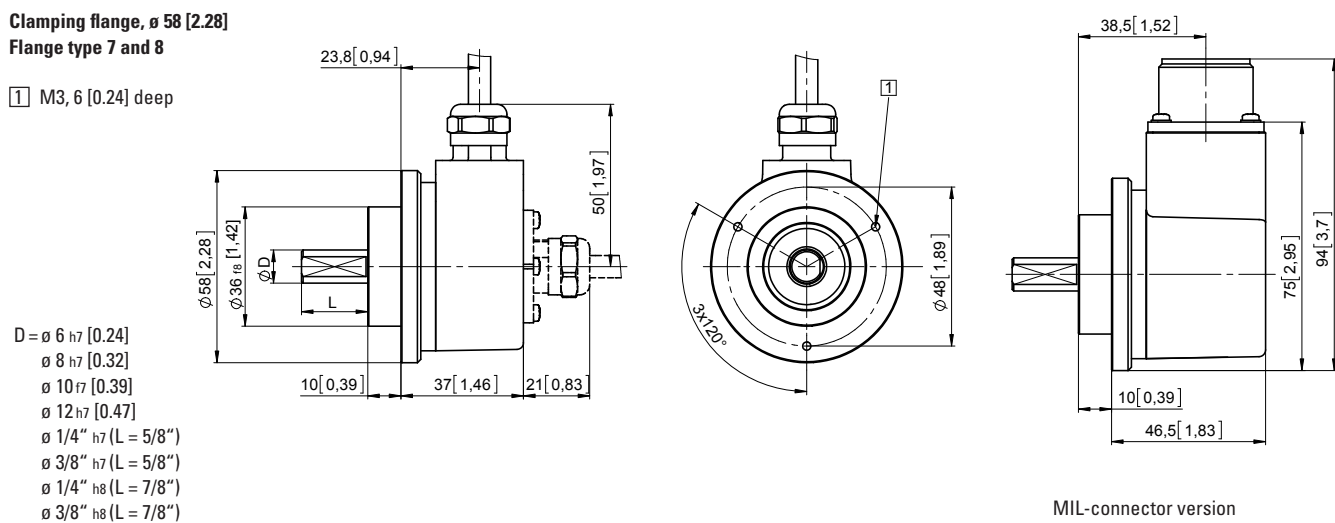

- D = ø 6 h7 [0.24]  
 ø 8 h7 [0.32]  
 ø 10 f7 [0.39]  
 ø 12 h7 [0.47]  
 ø 1/4" h7 (L = 5/8")  
 ø 3/8" h7 (L = 5/8")  
 ø 1/4" h8 (L = 7/8")  
 ø 3/8" h8 (L = 7/8")

MIL-connector version

### Synchro flange, ø 58 [2.28] Flange type A and B

1 M4, 6 [0.24] deep

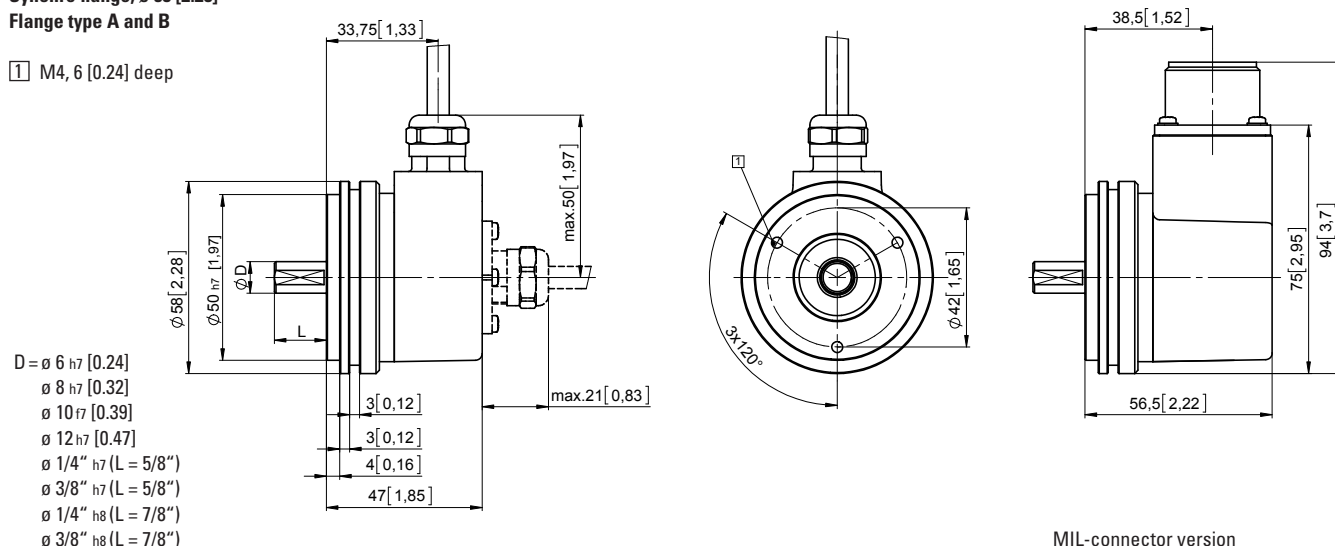

- D = ø 6 h7 [0.24]  
 ø 8 h7 [0.32]  
 ø 10 f7 [0.39]  
 ø 12 h7 [0.47]  
 ø 1/4" h7 (L = 5/8")  
 ø 3/8" h7 (L = 5/8")  
 ø 1/4" h8 (L = 7/8")  
 ø 3/8" h8 (L = 7/8")

MIL-connector version

Incremental encoders

# Incremental encoders

**Standard optical**

**Sendix 5000 / 5020 (shaft / hollow shaft)**

**Push-Pull / RS422**

## Dimensions shaft version

Dimensions in mm [inch]

**Square flange, □ 63.5 [2.5]**  
**Flange type C and D**

- D =  $\varnothing$  6 h7 [0.24]
- $\varnothing$  8 h7 [0.32]
- $\varnothing$  10 h7 [0.39]
- $\varnothing$  12 h7 [0.47]
- $\varnothing$  1/4" h7 (L = 5/8")
- $\varnothing$  3/8" h7 (L = 5/8")
- $\varnothing$  1/4" h8 (L = 7/8")
- $\varnothing$  3/8" h8 (L = 7/8")

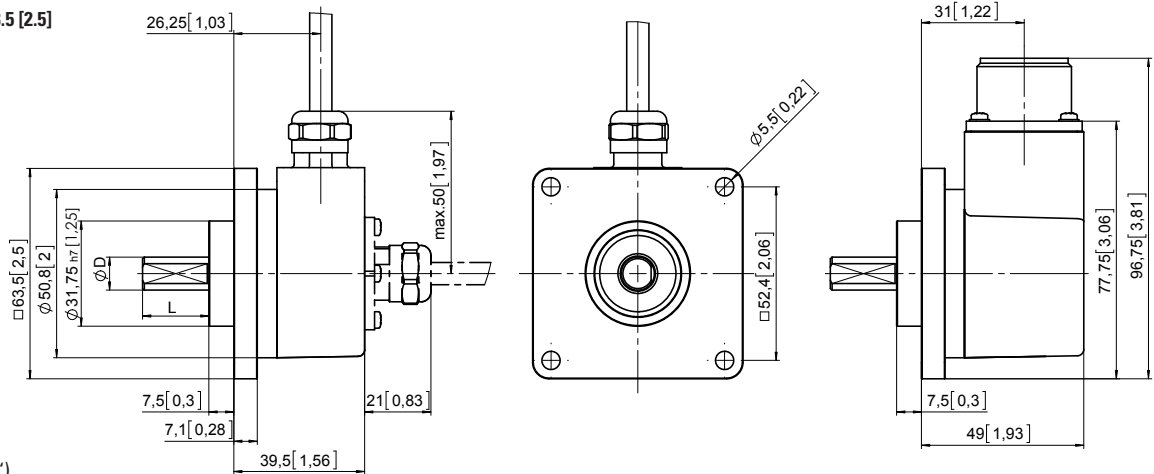

MIL-connector version

**Euro flange,  $\varnothing$  115 [4.53]**

**Flange type G**

1 Feather key attached

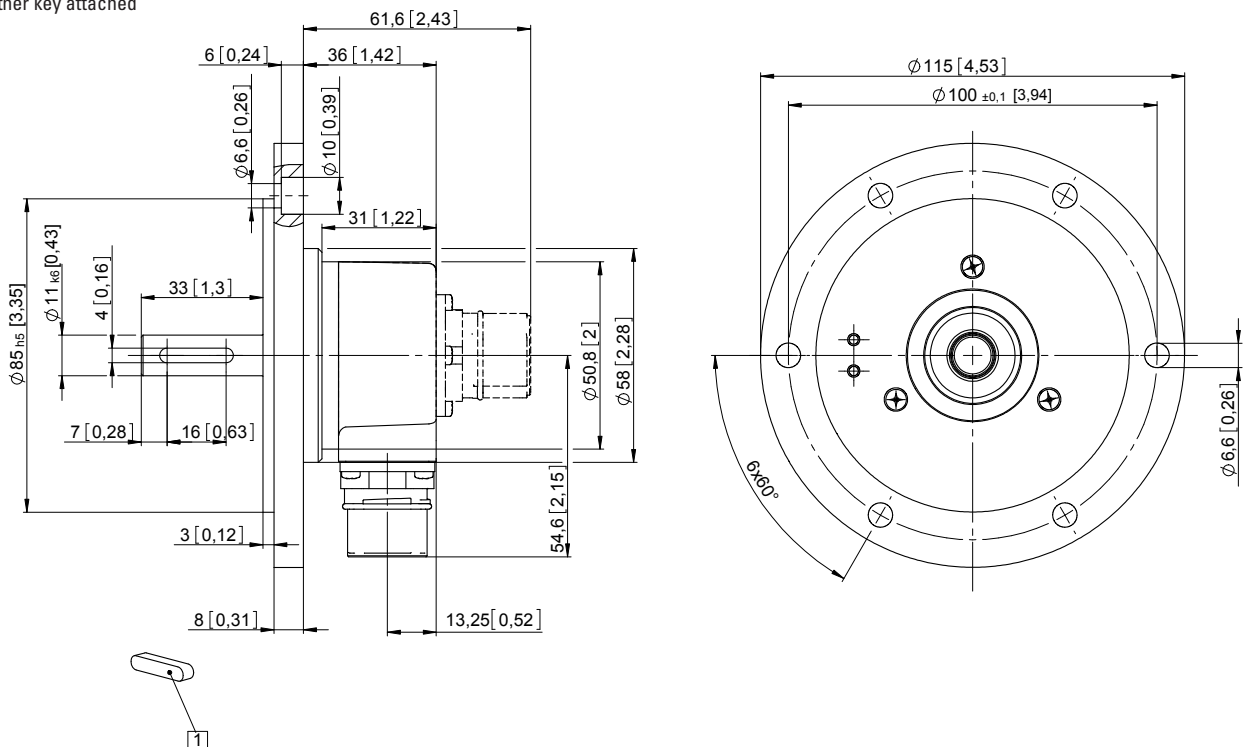

# Incremental encoders

<b>Standard optical</b>	<b>Sendix 5000 / 5020 (shaft / hollow shaft)</b>	<b>Push-Pull / RS422</b>
-------------------------	--	--------------------------

## Dimensions shaft version

Dimensions in mm [inch]

### Servo flange, $\varnothing 50.8$ [2] Flange type 1 and 2

- 1 6-32 UNC x 5 [0.2] deep
- 2 4-40 UNC x 6 [0.24] deep

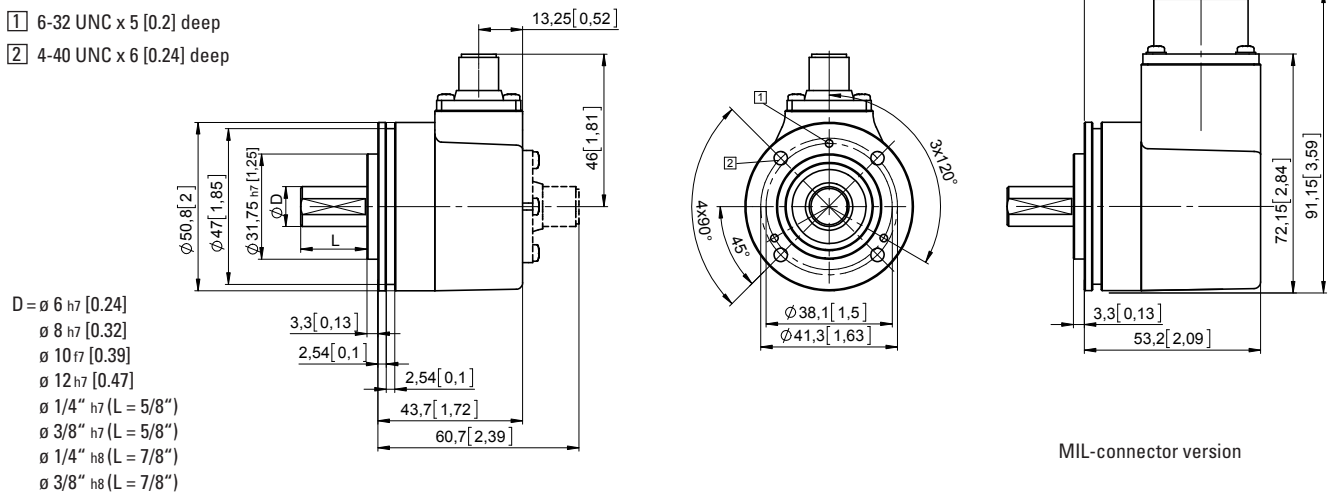

### Square flange, $\square 50.8$ [2] Flange type 3 and 4

- 1  $\varnothing 4$  [0.16]
- 2 6-32 UNC x 5 [0.2] deep

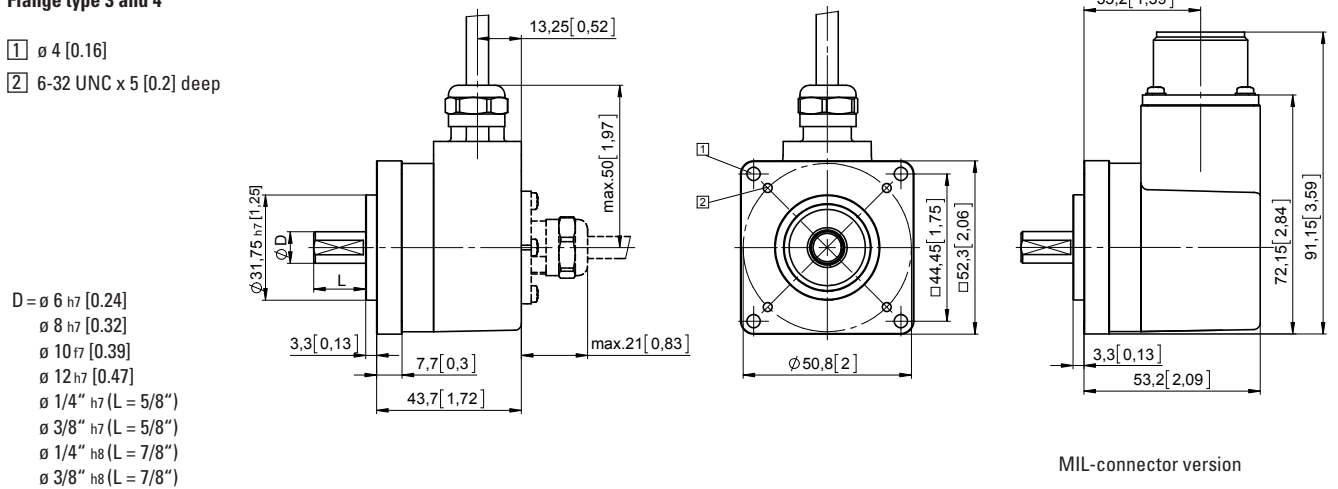

### Servo flange, $\varnothing 63.5$ [2.5] Flange type E and F

- 1 6-32 UNC

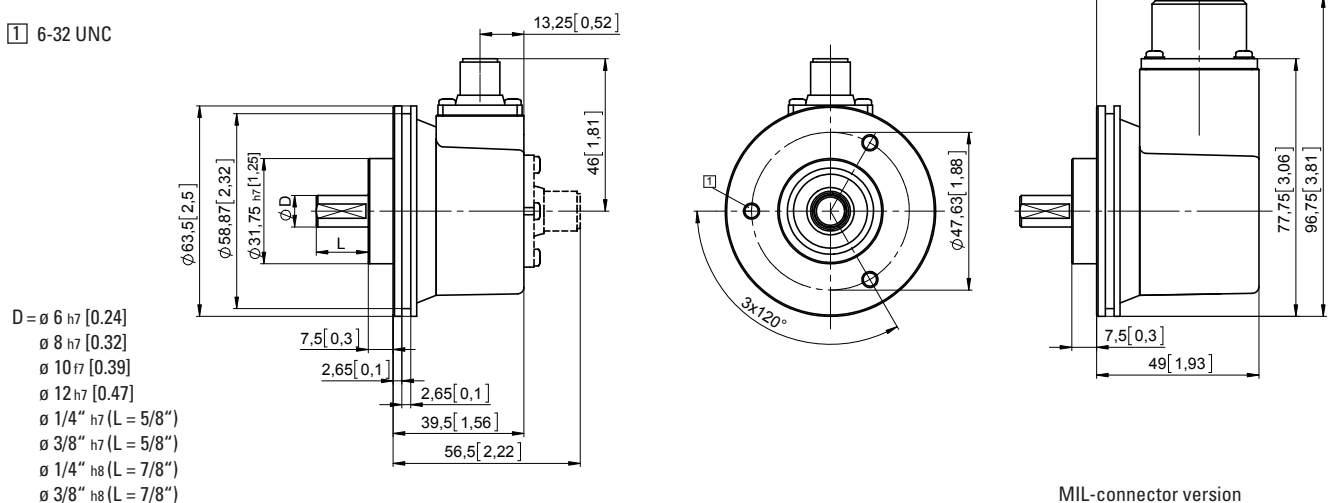

Incremental encoders

# Incremental encoders

**Standard optical**

**Sendix 5000 / 5020 (shaft / hollow shaft)**

**Push-Pull / RS422**

## Dimensions hollow shaft version

Dimensions in mm [inch]

### Flange with spring element, long Flange type 1 and 2

- 1 M3, 6 [0.24] deep
- 2 Torque stop slot,  
recommendation: cylindrical pin DIN7, 4 [0.16]
- 3 Recommended torque for the clamping ring 0.6 Nm

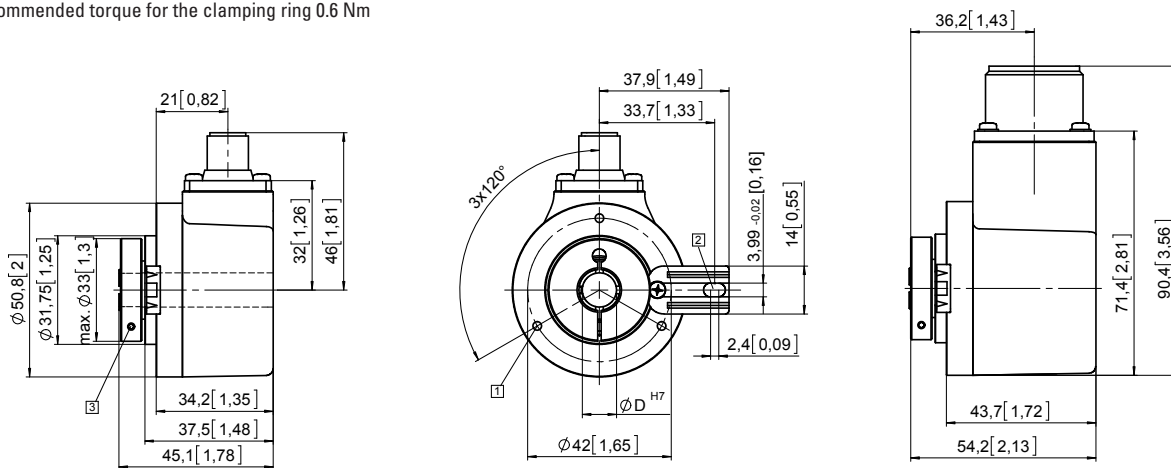

MIL-connector version

### Flange with fastening arm, long Flange type 3 and 4

- 1 Recommended torque for the clamping ring 0.6 Nm

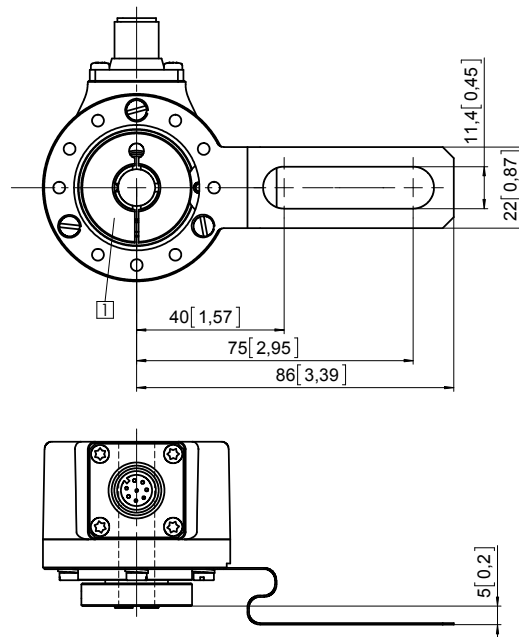

# Incremental encoders

<b>Standard optical</b>	<b>Sendix 5000 / 5020 (shaft / hollow shaft)</b>	<b>Push-Pull / RS422</b>
-------------------------	--	--------------------------

## Dimensions hollow shaft version

Dimensions in mm [inch]

**Flange with stator coupling,  $\varnothing$  65 [2.56]**  
**Flange type 7 and 8**

1 Recommended torque for the clamping ring 0.6 Nm

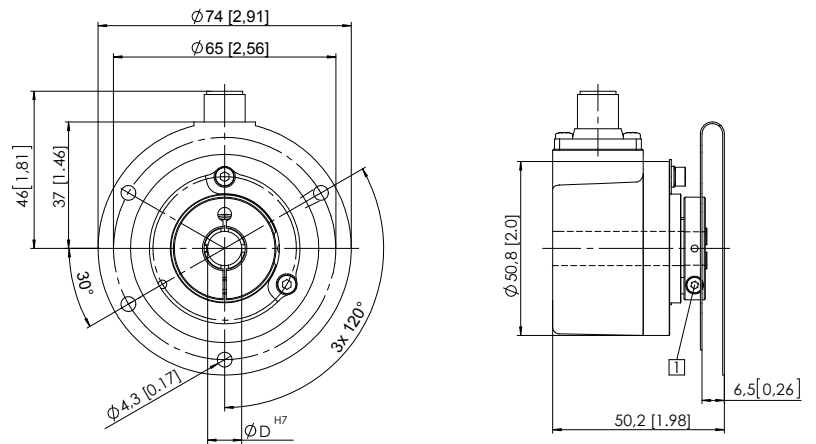

Incremental encoders

**Flange with stator coupling,  $\varnothing$  63 [2.48]**  
**Flange type C and D**

1 Recommended torque for the clamping ring 0.6 Nm

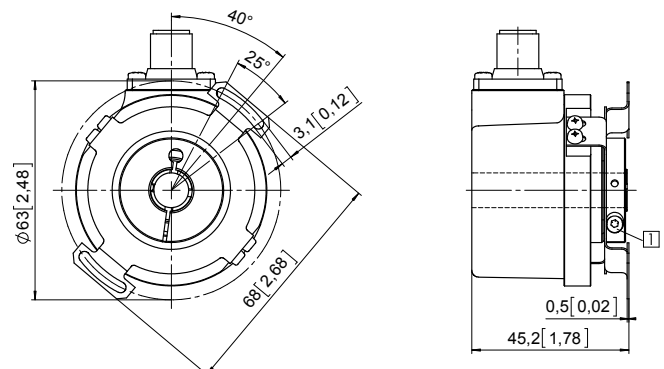

**Flange with stator coupling,  $\varnothing$  57.2 [2.25]**  
**Flange type 5 and 6**

1 Recommended torque for the clamping ring 0.6 Nm

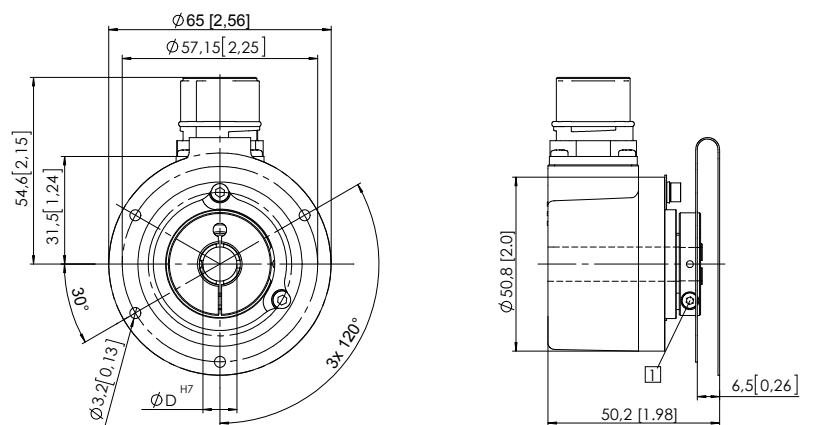

# Incremental encoders

<b>Standard optical</b>	<b>Sendix 5000 / 5020 (shaft / hollow shaft)</b>	<b>Push-Pull / RS422</b>
-------------------------	--	--------------------------

## Dimensions hollow shaft version

Dimensions in mm [inch]

**Flange with spring element, long and tangential cable outlet**  
**Type of connection E, F and H**

- 1 M3, 6 [0.24] deep
- 2 Torque stop slot,  
recommendation: cylindrical pin DIN7, 4 [0.16]
- 3 Recommended torque for the clamping ring 0.6 Nm

