



MAGNETROL®

AMETEK®

LEVEL MEASUREMENT
SOLUTIONS

Tuffy® II Liquid Level Controls with Electric Switches

DESCRIPTION

The Tuffy® II Liquid Level Switches are float-actuated devices designed for horizontal mounting in a tank or vessel through threaded or flanged pipe connections. The compact size allows for installation in small vessels, while its many features provide a variety of application uses. The single switch mechanism is available in SPDT or DPDT forms on units designed for fixed or adjustable, narrow or wide differential and interface service levels. This bulletin covers Tuffy II level controls with electric switches. For Tuffy with a pneumatic switch, see bulletin 44-109.

TECHNOLOGY

The Tuffy II achieves switching action through the use of a magnetic switch mechanism and a magnet attached to the float assembly. Separating the two magnets is a non-magnetic pressure barrier.

As the liquid level changes, the float, and therefore the float magnet, moves. The float and switch magnets repel each other causing movement of the switch magnet assembly, tripping the switch and making or breaking an electrical circuit.

FEATURES

- Pressure ratings to 2625 psi (181 bar)
- Process temperatures to +900 °F (+482 °C)
- Cost-effective clad flange design option
- NACE, ASME B31.1 and ASME B31.3 construction
- Specific gravity as low as 0.40
- SIL 2 suitable (FMEDA report available upon request)

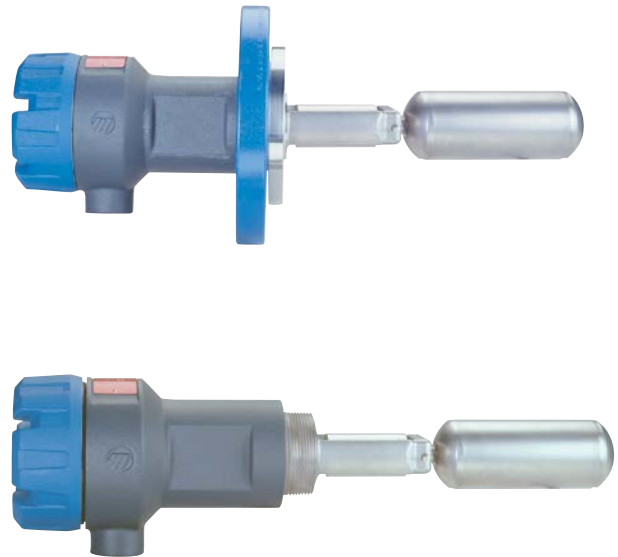

APPLICATIONS

- Sour service (NACE)
- High/low alarm
- Single pump control
- Day storage tanks
- Corrosive processes (Hastelloy® C wetted parts)
- Process vessels
- Boiler low water cut-off
- Interface level
- Explosion proof installations

ADDITIONAL FEATURES

- Carbon steel with 316 SS, all 316 SS or all Hastelloy C wetted components
- Enlarged switch enclosure for wiring ease
- Explosion proof NEMA 4X/7/9 enclosure
- All models available with FM, CSA and ATEX approvals
- Choice of cast aluminum or cast iron switch enclosure
- Interface service with 0.10 minimum specific gravity difference
- External cages available in carbon steel and 316 stainless steel
- Fixed narrow differential models
- Adjustable wide differential models
- Wide selection of process connections:
 - 2" NPT
 - 3" to 6" ANSI flanges
 - ANSI flanges pressure classes from 150# to 1500#
- Wide selection of switches:
 - SPDT or DPDT
 - Silver or gold contacts
 - Dry contact
 - Hermetically sealed

PHYSICAL SPECIFICATIONS/FUNCTIONAL/PHYSICAL

Measured Variable:	Liquid level	
Deadband:	Narrow differential = 0.50" Wide differential = up to 18.26"	
	Interface service differential 1.72"	
Float Material:	316 stainless steel or Hastelloy C	
Float Holder:	Investment cast stainless steel	
Flange Materials:	Carbon steel, 316 stainless steel, 316 stainless steel clad carbon steel Hastelloy C, or Hastelloy C clad carbon steel	
Process Connections:	2" NPT, 3" to 6" ANSI flanges in 150# to 900# pressure classes	
Maximum Process Pressure:	2630 psig (181 bar)	
Ambient Temp. Range*:	0 to +100 °F (-18 to +38 °C)	
Process Temp Range*:	Cast Iron Housing	Cast Aluminum Housing
HS with silver contacts	-65 to +750 °F (-54 to +399 °C)	-65 to +650 °F (-54 to +343 °C)
HS with gold contacts	-65 to +750 °F (-54 to +399 °C)	-65 to +650 °F (-54 to +343 °C)
Snap with silver contacts	-40 to +750 °F (-40 to +399 °C)	-40 to +650 °F (-40 to +343 °C)
Snap with gold contacts	-40 to +375 °F (-40 to +190 °C)	-40 to +325 °F (-40 to +162 °C)

* For ambient temperatures outside of the listed range, consult factory or bulletin 44-607 for maximum allowable process temperature.

ELECTRICAL SPECIFICATIONS

Signal Output:	Switch closure
Type of Contacts:	SPDT or DPDT
Contact Material:	Silver or gold
Type of Switches:	Dry contact or Hermetically sealed
Switch Ratings:	Up to 10 amps @ 120/240 VAC Up to 6 amps @ 24 VDC
Enclosure Rating:	NEMA 4X/7/9, Class I, Div 1, Groups B, C & D, IP66
Enclosure Material:	Cast aluminum or cast iron
Cable Entry:	3/4" NPT

DIMENSIONAL SPECIFICATIONS

INCHES (MM)

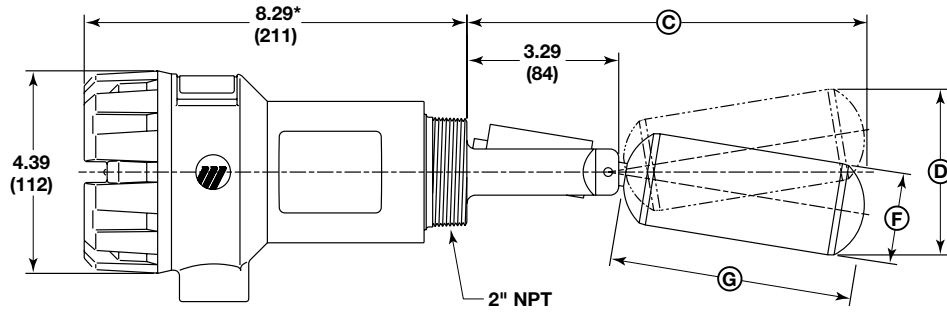

2" NPT Narrow Differential Unit (T31, T35)

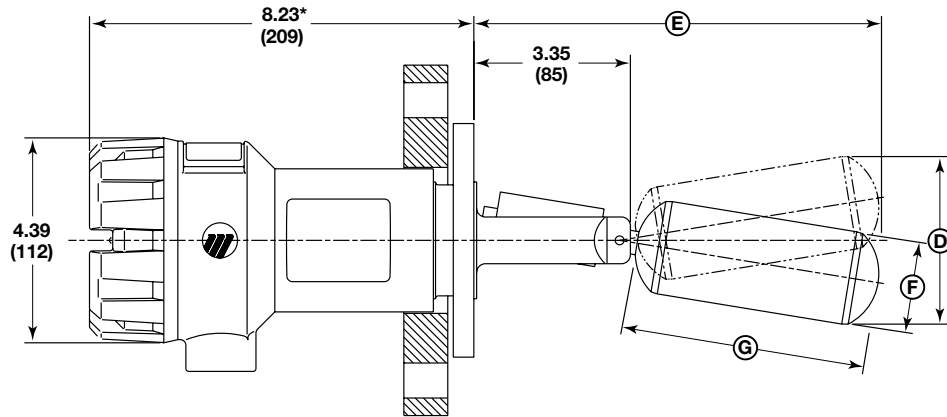

Flanged Narrow Differential Unit (T31, T32, T33, T34, T35)

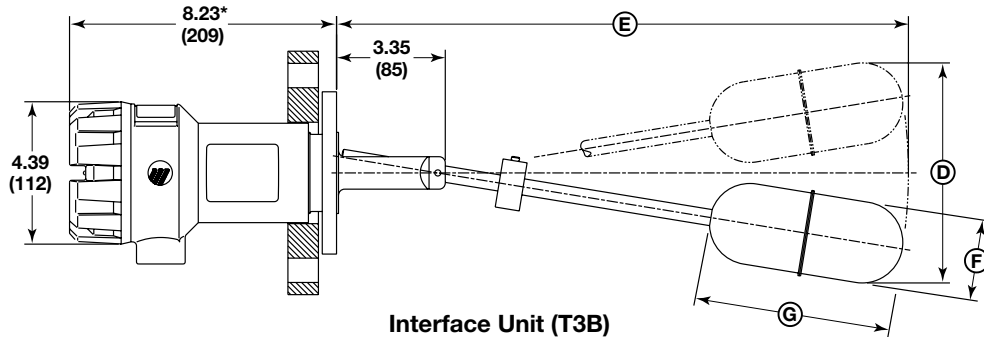

Interface Unit (T3B)

* This dimension applies to cast iron housing. Subtract 0.31" (8 mm) for aluminum housing.

Dimension	T31	T32	T33	T34	T35	T3B	T3C		
B	—	—	—	—	—	—	3.75 (95)	7.5 (190)	12.25 (311)
C	8.66 (220)	—	—	—	7.86 (199)	—	—	—	—
D	3.59 (91)	3.36 (85)	3.58 (91)	3.59 (91)	3.33 (85)	6.78 (172)	13.62 (346)	18.54 (471)	24.76 (629)
E	8.72 (221)	8.02 (204)	7.50 (190)	7.97 (202)	7.92 (201)	17.62 (448)	12.86 (327)	16.61 (422)	21.36 (543)
F	2.00 (51)	2.00 (51)	2.38 (60)	2.00 (51)	2.00 (51)	2.66 (68)	2.66 (68)		
G	5.25 (133)	4.55 (116)	4.00 (102)	4.50 (114)	4.45 (113)	6.00 (152)	6.00 (152)		
Maximum Nozzle Length	3.29 (84)	3.35 (85)	3.35 (85)	3.35 (85)	3.29 (84)	5.80 (147)	4.35 (110)		

DIMENSIONAL SPECIFICATIONS

INCHES (MM)

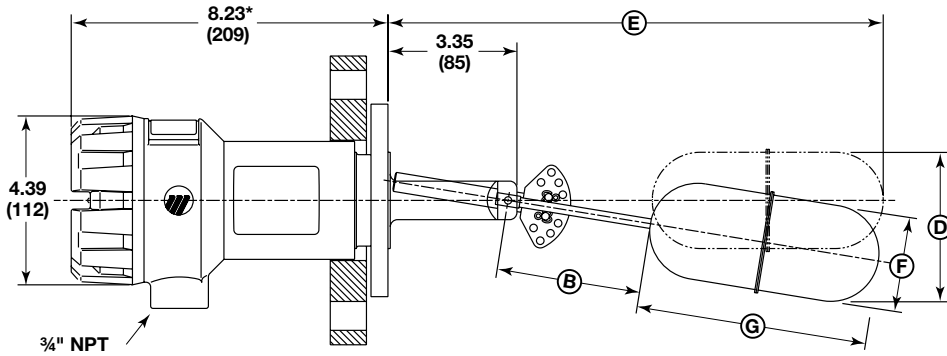

Adjustable Differential Unit (T3C)

* This dimension applies to cast iron housing.
Subtract 0.31" (8 mm) for aluminum housing.

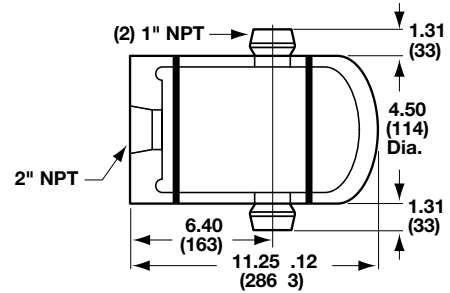

Tuffy® Chamber

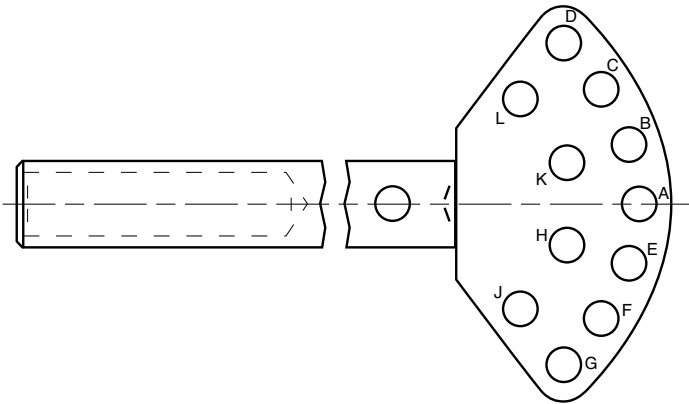

Adjustment Plate Stop Position



Tuffy® II Maximum Nozzle Lengths (distance from face of mounting flange to end of 3" sch 80 nozzle or the tip of the mounting threads to the end of 2" nozzle with ID same as 2" NPT)	
T31 or T35 with NPT connection	3.29"
T31, T32, T33, T34 or T35 with flanged connection	3.35"
T3B	5.80"
T3C	4.35"

Figure 1
Maximum Nozzle Length

	Stem Length	Pin Position										
		A	B	C	D	E	F	G	H	J	K	L
Rising	3.75	+0.16	+1.84	+3.54	+4.87	-1.47	n/a	n/a	-1.65	n/a	+1.52	+4.10
	7.50	-0.12	+2.49	+5.14	+7.20	-2.65	n/a	n/a	-2.94	n/a	+1.99	+6.01
	12.25	-0.43	+3.36	+7.20	+10.20	-4.12	n/a	n/a	-4.54	n/a	+2.62	+8.46
Falling	3.75	+1.51	+3.14	n/a	n/a	-0.39	-1.87	-3.21	0.16	-2.44	+3.32	n/a
	7.50	+1.98	+4.51	n/a	n/a	-0.99	-3.29	-5.37	-0.12	-4.16	+4.80	n/a
	12.25	+2.61	+6.28	n/a	n/a	-1.69	-5.04	-8.06	-0.44	-6.31	+6.71	n/a

Stop Position Actuation Levels
(Inches (± 0.25) at minimum S.G.)

AGENCY APPROVALS

AGENCY	APPROVED MODEL	PROTECTION METHOD	AREA CLASSIFICATION
FM 	T3X-XXXX-XXA T3X-XXXX-XXB T3X-XXXX-XXC T3X-XXXX-XXD	Explosion Proof	Class I, Div 1; Groups B, C, D Class II, Div 1; Groups E, F, G Class III, Type 4X IP66
ATEX 	T3X-XXXX-XX1 T3X-XXXX-XX2 T3X-XXXX-XX3 T3X-XXXX-XX4	Flame Proof Certificate BK119ATEX0015X, applied standards EN IEC 60079-0:2018 EN60079-1:2014 and EN60079-26:2015	II 1/2 G Ex d IIC T6 Ga/Gb IP66
	T3X-XXXX-XXM T3X-XXXX-XXN T3X-XXXX-XXP T3X-XXXX-XXR	Intrinsically Safe ① Certificate KIWA 18ATEX0022X applied standards EN60079-0:2012+ A11:2013, EN60079-11:2012	II 1 G Ex ia IIC T6 Ga IP66
IEC	T3X-XXXX-XX1 T3X-XXXX-XX2 T3X-XXXX-XX3 T3X-XXXX-XX4	Flame Proof Certificate BK113.0006 applied standards IEC60079-0:2011, IEC 60079-1:2007, IEC 60079-26:2006	Exd IIC T6 Ga/Gb IP66
	T3X-XXXX-XXM T3X-XXXX-XXN T3X-XXXX-XXP T3X-XXXX-XXR	Intrinsically Safe ① Certificate IECEx KIWA 18.0011X applied standards IEC 60079-0:2011 and IEC 60079-11:2011	Ex ia IIC T6 Ga IP66
CE 	T3X-XXXX-XXX	Low Voltage Directives 2014/30/EU Per Horizontal Standard: EN 61010-1/1993 & Amendment No.	Installation Category II Pollution Degree 2

Special conditions for safe use:

- ① When the material is equipped with an aluminum enclosure, all precautions shall be taken to avoid all impacts or frictions which can result in the ignition of the potentially explosive atmosphere.

MODEL NUMBERS

- Narrow Differential:** Switch differential of approximately 0.5" (1.7" on interface unit), for actuation of an alarm or system shutdown.
- Interface Service:** Switch to detect the interface between two liquids with SGUs that differ by at least 0.1.
- Single Liquid:** Switch to detect the top of layer of a single liquid with no other liquid above it.
- Adjustable Differential:** Wide switch differential from approximately 1.36" to 18.26", which may be adjusted in the field by repositioning pins on the adjustment plate.

BASIC MODEL FLOW CHART

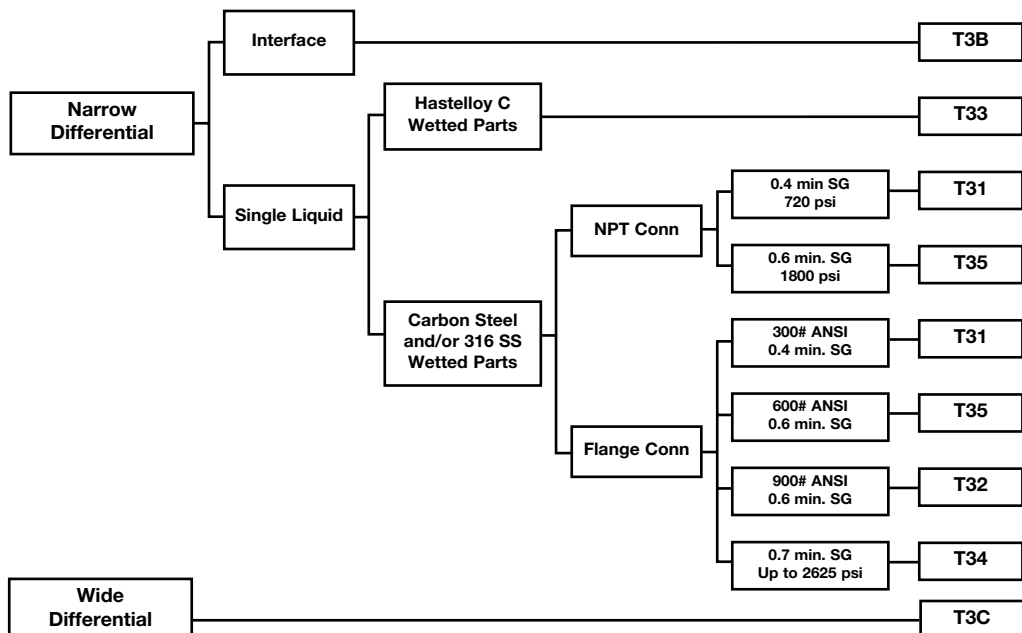

MODEL NUMBER

STANDARD NARROW DIFFERENTIAL

BASIC MODEL NUMBER

T 3	Tuffy II Electric Liquid Level Switch
------------	---------------------------------------

FUNCTION/FLOAT

Code	Level Differential	SGU Min	① Max. Pressure psig (bar)	Compatible Model Codes		
				Process Connection Size Codes	Process Connection Type Codes	Process Connection Material/Design Codes
1	Narrow (0.5")	0.40	750 (52)	All	N, A, B	A,B,E,F,J,K,N,P,1,2
2		0.60	2220 (153)	3, 4, 5, 6	A, B, C, D	A,B,E,F,J,K,N,P,1,2
3		0.65	750 (52)	3, 4, 5, 6	A, B	C,D,G,H,L,M,R,T
4		0.70	2630 (181)	4	E	A,B,E,F,J,K,N,P,1,2
5		0.60	1800 (124)	All	N, A, B, C	A,B,E,F,J,K,N,P,1,2

PROCESS CONNECTION SIZE

Code	Size	Compatible Model Codes		
		Function/Float Codes	Process Connection Type Codes	Process Connection Material/Design Codes
2	2"	1, 5	N	B, F, K, P
3	ANSI 3"	1, 2, 3, 5	A, B, C, D	All
4	ANSI 4"	1, 2, 3, 4, 5	A, B, C, D, E	All
5	ANSI 5"	1, 2, 3, 5	A, B	All
6	ANSI 6"	1, 2, 3, 5	A, B	All

PROCESS CONNECTION TYPE ①

Code	Type	Compatible Model Codes		
		Function/Float Codes	Process Connection Size Codes	Process Connection Material/Design Codes
N	NPT	1, 5	2	B, F, K, P
A	ANSI RF Flange, 150#	1, 2, 3, 5	3, 4, 5, 6	All
B	ANSI RF Flange, 300#	1, 2, 3, 5	3, 4, 5, 6	All
C	ANSI RF Flange, 600#	2, 5	3, 4	A,B,E,F,J,K,N,P,1,2
D	ANSI RF Flange, 900#	2, 5	3, 4	A,B,E,F,J,K,N,P,1,2
E	ANSI RF Flange, 1500#	4	4	A,B,E, F, J,K,N,P,1,2

PROCESS CONNECTION MATERIAL/DESIGN CODE

SWITCH TYPE

HOUSING MATERIAL/APPROVAL

See opposite page

① Rated pressure limited by maximum float or flange pressure, whichever is less.

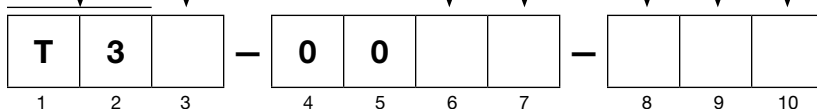

MODEL NUMBER

STANDARD NARROW DIFFERENTIAL (continued)

PROCESS CONNECTION MATERIAL/DESIGN CODE

Standard	ASME B31.1 & ASME B31.3	NACE	ASME B31.1, ASME B31.3 & NACE	Process Connection Material	Compatible Model Codes		
					Function/Float Codes	Process Connection Size Codes	Process Connection Type Codes
1	2	Not applicable	Not applicable	Carbon Steel Flange and cladding with 316/316L Stainless Steel float	1, 2, 4, 5	3, 4, 5, 6	A, B, C, D, E
A	E	J	N	Carbon Steel Flange with 316/316L SS process wetted face	1, 2, 4, 5	3, 4, 5, 6	A, B, C, D, E
B	F	K	P	All 316/316L Stainless Steel	1, 2, 4, 5	All	All
C	G	L	R	Carbon Steel Flange with Hastelloy C process wetted face	3	3, 4, 5, 6	A, B
D	H	M	T	All Hastelloy C	3	3, 4, 5, 6	A, B

SWITCH TYPE

Code	Contact Type and Material	Electric Switch Rating				Maximum Process Temperature ①②	
		VAC		VAC		Cast Iron Housing	Cast Alum. Housing
		120	240	24	120		
0	SPDT w/silver contacts	10.0	10.0	6.0	0.6	+750 °F (+399 °C)	650 °F (+343 °C)
1	DPDT (dual SPDT) w/silver contacts	10.0	10.0	6.0	0.6	+750 °F (+399 °C)	650 °F (+343 °C)
2	SPDT w/gold plated contacts	0.1	—	0.1	—	+375 °F (+190 °C)	325 °F (+162 °C)
3	DPDT (dual SPDT) w/gold plated contacts	0.1	—	0.1	—	+375 °F (+190 °C)	325 °F (+162 °C)
4	HS SPDT w/silver contacts	1.0	1.0	3.0	0.5	+750 °F (+399 °C)	650 °F (+343 °C)
6	HS SPDT w/gold plated contacts	0.5	0.5	0.5	0.5	+750 °F (+399 °C)	650 °F (+343 °C)
7	High-temp HS SPDT w/silver contacts	2.5	—	4.0	0.3	+900 °F (+482 °C)	—

① Maximum process temperature is based on an ambient temperature between 0 °F and +100 °F. If ambient is outside this range, consult factory.

② See switch temperature ranges on page 2 for minimum process temperatures

HOUSING MATERIAL/APPROVAL

FM	FMc	ATEX Ex d	ATEX IS	IEC Ex d	
A	C	1	M	1	Cast Aluminum, ¼" NPT Conduit Entry
B	D	2	N	2	Cast Iron, ¼" NPT Conduit Entry
N/A		3	P	3	Cast Aluminum, M20 × 1.5 Conduit Entry
		4	R	4	Cast Iron, M20 × 1.5 Conduit Entry

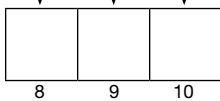

CHAMBER

PART NUMBER

MATERIALS OF CONSTRUCTION/PRESSURE RATING

0-001	Carbon Steel	2200 psig @ +400 °F (152 bar @ +204 °C), 1400 psig @ +750 °F (97 bar @ +399 °C)
0-002	316 Stainless Steel	2500 psig @ +400 °F (172 bar @ +204 °C), 2013 psig @ +750 °F (139 bar @ +399 °C)
1-001	Carbon Steel	1200 psig @ +400 °F (83 bar @ +204 °C), 780 psig @ +750 °F (54 bar @ +399 °C)
1-002	316 Stainless Steel	1400 psig @ +400 °F (97 bar @ +204 °C), 1127 psig @ +750 °F (78 bar @ +399 °C)

Note: Flanged chambers and process flanges available. Consult factory.

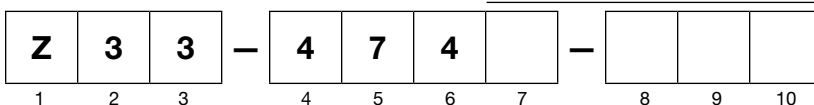

MODEL NUMBER

INTERFACE

Process Connection: ANSI Flanges
Wetted Materials: Carbon Steel and/or 316/316L SS
Max. Float Pressure: 750 psi (52 bar) ①
Min. SG of Lower Liquid: 0.81
Min SG difference: 0.1
Level Differential: 1.72"

BASIC MODEL NUMBER

T 3	Tuffy II Electric Liquid Level Switch
------------	---------------------------------------

FUNCTION/FLOAT

B	Interface Level
----------	-----------------

LOWER FLUID SPECIFIC GRAVITY

0.81	0.82	0.83	0.84	0.85	0.86	0.87	0.88	0.89	0.90	Specific Gravity
A	B	C	D	E	F	G	H	J	K	Code
0.91	0.92	0.93	0.94	0.95	0.96	0.97	0.98	0.99	1.00	Specific Gravity
L	M	N	P	R	S	T	U	V	W	Code

PROCESS CONNECTION SIZE

3	ANSI 3"
4	ANSI 4"
5	ANSI 5"
6	ANSI 6"

PROCESS CONNECTION TYPE ①

A	ANSI RF Flange, 150#
B	ANSI RF Flange, 300#

① Rated pressure limited by maximum float or flange pressure, whichever is less.

PROCESS CONNECTION MATERIAL/DESIGN CODE

SWITCH TYPE

HOUSING MATERIAL/APPROVAL

See opposite page

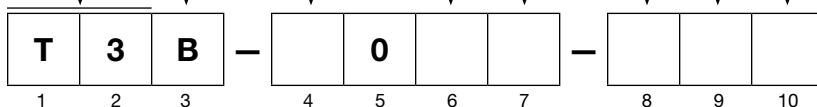

MODEL NUMBER

STANDARD NARROW DIFFERENTIAL (continued)

PROCESS CONNECTION MATERIAL/DESIGN CODE

Standard	ASME B31.1 & ASME B31.3	NACE	ASME B31.1, ASME B31.3 & NACE	Process Connection Material
1	2	Not applicable	Not applicable	Carbon Steel Flange and cladding with 316/316L SS float
A	E	J	N	Carbon Steel Flange with 316/316L SS process wetted face
B	F	K	P	All 316/316L Stainless Steel

SWITCH TYPE

Code	Contact Type and Material	Electric Switch Rating				Maximum Process Temperature ^{① ②}	
		VAC		VAC		Cast Iron Housing	Cast Alum. Housing
		120	240	24	120		
0	SPDT w/silver contacts	10.0	10.0	6.0	0.6	+750°F (+399°C)	+650°F (+343°C)
1	DPDT (dual SPDT) w/silver contacts	10.0	10.0	6.0	0.6	+750° F (+399°C)	+650°F (+343°C)
2	SPDT w/gold plated contacts	0.1	—	0.1	—	+375°F (+190°C)	+325°F (+162°C)
3	DPDT (dual SPDT) w/gold plated contacts	0.1	—	0.1	—	+375°F (+190°C)	+325°F (+162°C)
4	HS SPDT w/silver contacts	1.0	1.0	3.0	0.5	+750°F (+399°C)	+650°F (+343°C)
6	HS SPDT w/gold plated contacts	0.5	0.5	0.5	0.5	+750°F (+399°C)	+650°F (+343°C)
7	High-temp HS SPDT w/silver contacts	2.5	—	4.0	0.3	+900°F (+482°C)	—

① Maximum process temperature is based on an ambient temperature between 0 °F and +100 °F. If ambient is outside this range, consult factory.

② See switch temperature ranges on page 2 for minimum process temperatures

HOUSING MATERIAL/APPROVAL

FM	FMc	ATEX Ex d	ATEX IS	IEC Ex d	
A	C	1	M	1	Cast Aluminum, ¾" NPT Conduit Entry
B	D	2	N	2	Cast Iron, ¾" NPT Conduit Entry
N/A		3	P	3	Cast Aluminum, M20 × 1.5 Conduit Entry
		4	R	4	Cast Iron, M20 × 1.5 Conduit Entry

8	9	10

MODEL NUMBER

ADJUSTABLE WIDE DIFFERENTIAL

- Process Connection:** ANSI Flanges
Wetted Materials: Carbon steel and/or 316/316L SS
Max. Float Pressure: 750 psi (52 bar) ①
Min SG: 0.78
Level Differential: Adjustable from 1.36" to 18.26"

BASIC MODEL NUMBER

T 3	Tuffy II Electric Liquid Level Switch
------------	---------------------------------------

FUNCTION/FLOAT

C	Adjustable Differential Level
----------	-------------------------------

STEM EXTENSION LENGTH "B" DIMENSION

4	3.75 inch (95 mm) stem extension
8	7.50 inch (190 mm) stem extension
C	12.25 inch (311 mm) stem extension

PROCESS CONNECTION SIZE

3	ANSI 3"
4	ANSI 4"
5	ANSI 5"
6	ANSI 6"

PROCESS CONNECTION TYPE ①

A	ANSI RF Flange, 150#
B	ANSI RF Flange, 300#

① Rated pressure limited by maximum float or flange pressure, whichever is less.

PROCESS CONNECTION MATERIAL/DESIGN CODE

SWITCH TYPE

HOUSING MATERIAL/APPROVAL

See opposite page

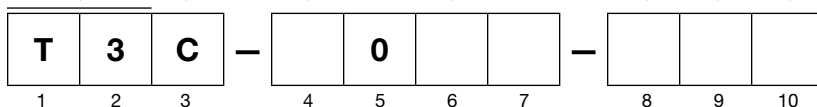

MODEL NUMBER

ADJUSTABLE WIDE DIFFERENTIAL (continued)

PROCESS CONNECTION MATERIAL/DESIGN CODE

Standard	ASME B31.1 & ASME B31.3	NACE	ASME B31.1, ASME B31.3 & NACE	Process Connection Material
1	2	Not applicable	Not applicable	Carbon Steel Flange and cladding with 316/316L SS float
A	E	J	N	Carbon Steel Flange with 316/316L SS process wetted face
B	F	K	P	All 316/316L Stainless Steel

SWITCH TYPE

Code	Contact Type and Material	Electric Switch Rating				Maximum Process Temperature ^{① ②}	
		VAC		VAC		Cast Iron Housing	Cast Alum. Housing
		120	240	24	120		
0	SPDT w/silver contacts	10.0	10.0	6.0	0.6	+750°F (+399°C)	+650°F (+343°C)
1	DPDT (dual SPDT) w/silver contacts	10.0	10.0	6.0	0.6	+750°F (+399°C)	+650°F (+343°C)
2	SPDT w/gold plated contacts	0.1	—	0.1	—	+375°F (+190°C)	+325°F (+162°C)
3	DPDT (dual SPDT) w/gold plated contacts	0.1	—	0.1	—	+375°F (+190°C)	+325°F (+162°C)
4	HS SPDT w/silver contacts	1.0	1.0	3.0	0.5	+750°F (+399°C)	+650°F (+343°C)
6	HS SPDT w/gold plated contacts	0.5	0.5	0.5	0.5	+750°F (+399°C)	+650°F (+343°C)
7	High-temp HS SPDT w/silver contacts	2.5	—	4.0	0.3	+900°F (+482°C)	—

① Maximum process temperature is based on an ambient temperature between 0 °F and +100 °F. If ambient is outside this range, consult factory.

② See switch temperature ranges on page 2 for minimum process temperatures

HOUSING MATERIAL/APPROVAL

FM	FMc	ATEX Ex d	ATEX IS	IEC Ex d	
A	C	1	M	1	Cast Aluminum, 3/4" NPT Conduit Entry
B	D	2	N	2	Cast Iron, 3/4" NPT Conduit Entry
N/A		3	P	3	Cast Aluminum, M20 × 1.5 Conduit Entry
		4	R	4	Cast Iron, M20 × 1.5 Conduit Entry

STOP POSITION ACTUATION LEVELS (INCHES ± 0.25 AT MINIMUM S.G.)

	Stem Length	Pin Position										
		A	B	C	D	E	F	G	H	J	K	L
Rising	3.75	+0.16	+1.84	+3.54	+4.87	-1.47	n/a	n/a	-1.65	n/a	+1.52	+4.10
	7.50	-0.12	+2.49	+5.14	+7.20	-2.65	n/a	n/a	-2.94	n/a	+1.99	+6.01
	12.25	-0.43	+3.36	+7.20	+10.20	-4.12	n/a	n/a	-4.54	n/a	+2.62	+8.46
Falling	3.75	+1.51	+3.14	n/a	n/a	-0.39	-1.87	-3.21	0.16	-2.44	+3.32	n/a
	7.50	+1.98	+4.51	n/a	n/a	-0.99	-3.29	-5.37	-0.12	-4.16	+4.80	n/a
	12.25	+2.61	+6.28	n/a	n/a	-1.69	-5.04	-8.06	-0.44	-6.31	+6.71	n/a

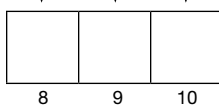

QUALITY

The quality assurance system in place at AMETEK LMS guarantees the highest level of quality throughout the company. AMETEK LMS is committed to providing full customer satisfaction both in quality products and quality service.

The AMETEK LMS quality assurance system is registered to ISO 9001 affirming its commitment to known international quality standards providing the strongest assurance of product/service quality available.

WARRANTY



All AMETEK LMS mechanical level and flow controls are warranted free of defects in materials or workmanship for three full years from the date of original factory shipment.

If returned within the warranty period; and, upon factory inspection of the control, the cause of the claim is determined to be covered under the warranty; then, AMETEK LMS will repair or replace the control at no cost to the purchaser (or owner) other than transportation.

AMETEK LMS shall not be liable for misapplication, labor claims, direct or consequential damage or expense arising from the installation or use of equipment. There are no other warranties expressed or implied, except special written warranties covering some AMETEK LMS products.



ametek-measurement.com

705 Enterprise Street • Aurora, Illinois 60504-8149 USA
630.969.4000 • info.magnetrol@ametek.com

Copyright © 2025 AMETEK Magnetrol USA, LLC

Performance specifications are effective with date of issue and are subject to change without notice.

BULLETIN: 44-106.17
EFFECTIVE: December 2024
SUPERSEDES: November 2019