



The Professional Choice

EBV

Accumulators



OLAER EBV | Low pressure bladder type conform to EC regulations

How to safeguard your installations?

The principle of precaution is always essential for everything related to the Oil activity. It is based on anticipating and adopting measures to prevent major risks.

Sudden flow changes in pipes (starting and stopping a pump, opening and closing a valve) cause pressure waves that propagate in pipes and cause leaks at connections, maladjustments of regulation devices, measurement devices, deterioration to the pump and the network. If correctly sized, the new range of EBV accumulators absorbs these oscillations, guaranteeing operation of your installations in complete safety within an acceptable pressure range.

With our new EBV range, we offer to measure overpressures on your network and make a commitment to provide the best technical solution adapted to your needs, so that you can benefit from our experience.

OLAER contributes to improving the safety of your system.

An example application

Considering the need to make its network of truck loading stations conform, an oil depot would like to optimize operation of his installations by taking all safety measures necessary in this field.

Comparative survey of pressures in an oil depot

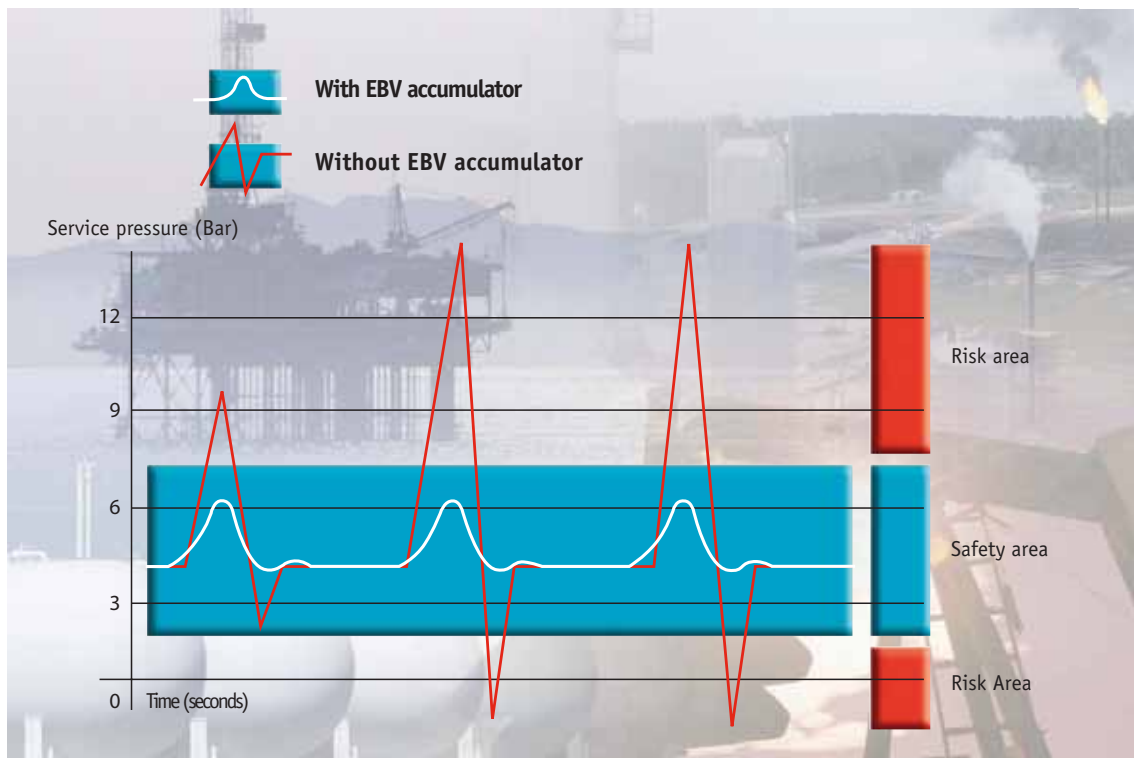

Main Features

Operating principle

Operation of the OLAER gas loaded bladder accumulator is based on the considerable difference in compressibility between a gas and a liquid, enabling a large quantity of energy to be stored in an extremely compact form. This enables a liquid under pressure to be accumulated, stored and recovered at any time.

Its special design allows the bladder (the strategic component) to compress the gas and usually form into three lobes in order for the accumulator to store, then to deliver the fluid under pressure, as required.

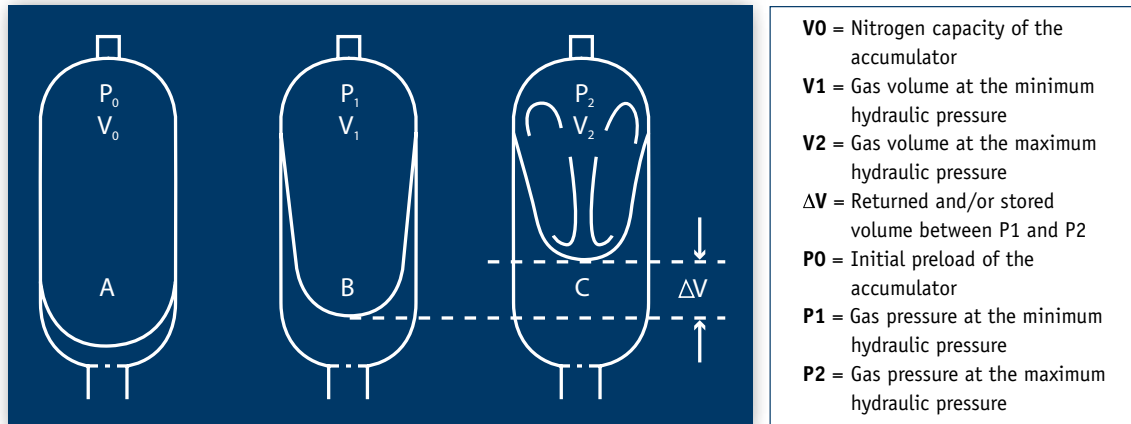

A - Bladder in the precharge position, means that it is only filled with nitrogen. The anti-extrusion system (perforated bushing) closes the hydraulic orifice and prevents the destruction of the bladder.

Maximum pressure differential : 4:1

B - Position at the minimum operating pressure; there must be a certain amount of fluid between the bladder and the hydraulic orifice, such that the anti-extrusion system (perforated bushing) does not close the hydraulic orifice. Thus, P_0 must always be $< P_1$.

C - Position at the maximum operating pressure: the volume change ΔV between the minimum and maximum positions of the operating pressures represents the fluid quantity stored.

Your Benefits

For flows greater than 130 m³/h in the networks, the EBV accumulator absorbs overpressures and compensates for pressure reductions generated by fast valve closures.

For example:

- Unleaded gasoline network
- Maximum network pressure = 10 Bar
- Feed : three 130 m³/h pumps at 4 Bar
- Valve closure in 3s.

Results:

- Without accumulator
 $P_{min} = -1$ Bar
 $P_{max} = 14$ bar
- With EBV accumulator 100-40/90 01180
 $P_{min} = 2.5$ bar
 $P_{max} = 8$ Bar

The precharge pressure must NOT exceed 20 bar

When starting pumps on a pressurized network, the overpressure generated by "putting the fluid mass into circulation" is compensated by the EBV accumulator. The EBV and ELG accumulator ranges conform with the new EC regulations.

Technical Characteristics

The accumulator comprises a forged or welded steel shell, a rubber bladder and anti-extrusion system.

- Shell material options include alloyed steel, stainless steel, aluminium, titanium and composites.
- Various bladder materials available which are compatible with a range of fluids and temperatures.
- Anti-extrusion system; perforated bushing.

Taking into account the different needs of various applications, Olaer offers different protections external and/or internal: Bare metal, nickel plating, epoxy paint, PTFE, Rilsan® and phenolic coating. This extensive range enables us to offer accumulators operating from -40 to $+130^{\circ}\text{C}$ with pressures of up to 80 Bar and capacities of up to 575 litres. Atex versions are also available for some accumulators in fluid groups 1 or 2 as per Article 9 section 2.1 and 2.2 of PED.

As the market leader in bladder type accumulators, Olaer has participated in the development of the EN 14359:2006 standard, which specifies the material, design, manufacturing, tests, safety devices and documentation (including the instruction manual), for pressure accumulators and gas bottles for hydraulic applications.

Technical Characteristics

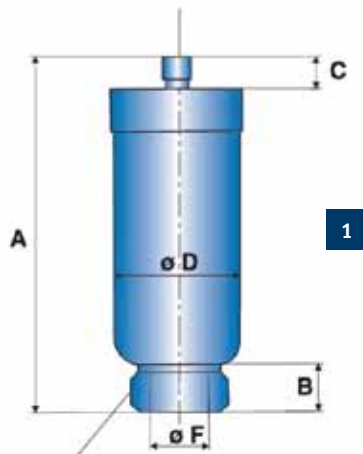

SW on flats

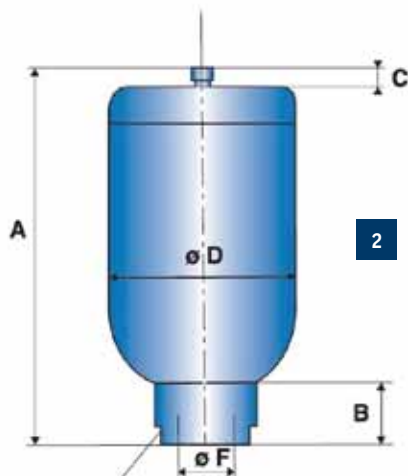

SW on flats

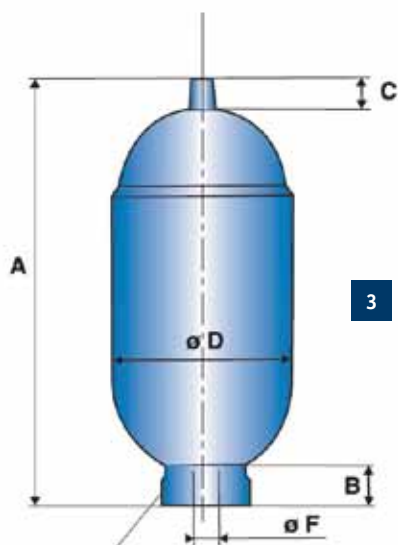

SW on flats

	1	2	3
Type	OLG 0.13-50/00	OLG 1-20/00	ELG 4-20/90
Max. pressure in bar	50	20	20
Nominal gas volume in l	0.13	1	3.8
Weight in kg	0.3	1.6	3.7
ø D maxi	50	107	155
A max height	136	210	340
Connection ø F	G 3/4" cyl.	G 1" cyl.	⁴ G 2" cyl.
ø spot facing x proof	33 x 0.5	-	73 x 1.5
B	16	30.5	40
C	13	11	16
SW on flats	6 hollow sides 360/F	2 flats 46 A/F	2 flats 82 O/F
P/N clamps x (quantity)	-	E 106 x 1	E 155 x 1

- 1** Conforming to the EC regulation 3.3 stainless steel
- 2** Conforming to the EC regulation 3.3
- 3** Conforming to the EC regulation stainless steel
- 4** Possibility with connection G 3/4" cyl.

The above measurements are given in mm and do not take manufacturing tolerances into consideration.

Technical Characteristics

EBV RANGE FROM 0.5 TO 5 LITERS - STANDARD CONSTRUCTION

Type	Effective Gas vol. Liters	Work pressure bar	Weight in Kilo	Clamps x (quantity)	O-ring $\phi_{int} \times \phi_{tore}$	Support bracket	Fittings & Flanges	Dimensions in mm						
								A max height	B	C	ϕD_{max}	ϕd	ϕH	ϕF connection
EBV 0.5-50/00*	0.5	50	2.2	E95	54x3	-	consult page 9	243	52	28	90	16	68	G 2" cyl.
EBV 1-80/00*	1	80	5	E114		CE 89		310	47	66	116	22.5	68	G 2" cyl.
EBV 2.5-80/90	2.3	80	9	E114		CE 89		482	47	66	116	22.5	68	G 2" cyl.
EBV 5-80/90	5	80	16	E114		CE 89		805	47	66	116	22.5	68	G 2" cyl.

* complying to the regulation EC 3.3

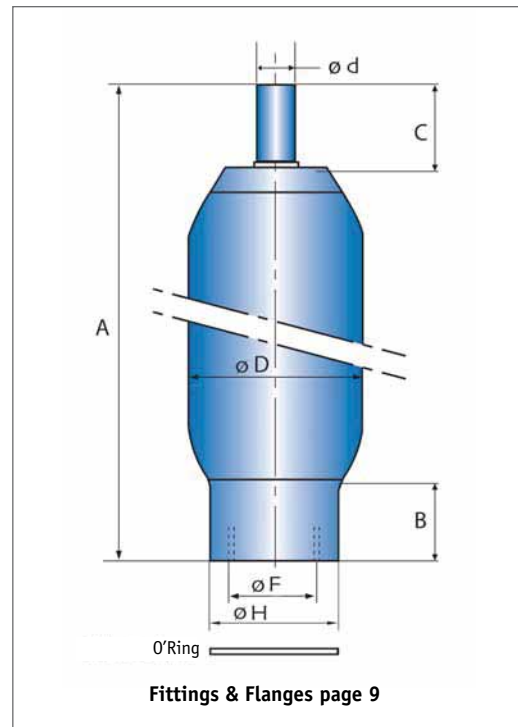

STAINLESS STEEL CONSTRUCTION

Type	Effective Gas vol. Liters	Work pressure bar	Weight in Kilo	Clamps x (quantity)	O-ring $\phi_{int} \times \phi_{tore}$	Support bracket	Fittings & Flanges	Dimensions in mm						
								A max height	B	C	ϕD_{max}	ϕd	ϕH	ϕF connection
EBV 0.5-40/00*	0.5	40	2.1	E95	54x3	-	consult page 9	240	54	29.5	90	16	70	G 2" cyl.
EBV 1-40/00*	1	40	2.8	E106		CE 89		308	52	75	109	22.5	70	G 2" cyl.
EBV 2.5-40/90	2.5	40	3.2	E106		CE 89		484	51	75	109	22.5	70	G 2" cyl.
EBV 5-40/90	5	40	6.2	E106		CE 89		867	51	75	109	22.5	70	G 2" cyl.

* complying to the regulation EC 3.3

The above measurements are given in mm and do not take manufacturing tolerances into consideration.

EBV RANGE FROM 10 TO 200 LITERS

Construction: 1 Standard steel & Stainless steel version - 2 Stainless steel version - 3 Standard steel version
This range is also available in Atex construction Category 2

Type	Effective Gas vol. Liters	Work pressure bar	Weight in Kilo	Clamps x (quantity)	O-ring ϕ int x ϕ tore	Support bracket	Fittings & Flanges	Flow max l/min	Construction	Dimensions in mm						
										A max height	B	C	ϕD max	ϕd	ϕH	ϕF connection
EBV 10-40/90	10	40	11	D215x2	96x4	CE 159	consult us	900	1	452	51	75	212	22.5	118	G3½" cyl.
EBV 20-40/90	18	40	19	D215x2	96x4	CE 159		900	1	774	51	75	212	22.5	118	G3½" cyl.
EBV 32-40/90	34	40	34	D215x2	96x4	CE 159		900	1	1307	51	75	212	22.5	118	G3½" cyl.
EBV 50-40/90	50	40	49	D215x2	96x4	CE 159		900	1	1829	51	83	212	22.5	118	G3½" cyl.
EBV 100-20/90	90	20	95	D368x2	196.21x5.33	C 300		3000	2	1315	158	93	371	80	224	M205x3
EBV 100-40/90	90	40	125	D368x2	196.21x5.33	C 300		3000	3	1315	158	93	371	80	224	M205x3
EBV 200-20/90	202	20	168	D368x2	196.21x5.33	C 300		3000	2	2526	158	93	371	80	224	M205x3
EBV 200-40/90	202	40	210	D368x2	196.21x5.33	C 300		3000	3	2526	158	93	371	80	224	M205x3

EBV RANGE FROM 100 TO 575 LITERS

Type	Effective Gas vol. Liters	Work pressure bar	Weight in Kilo	O-ring ϕ int x ϕ tore	Dimensions in mm unless stated otherwise and subject to manufacturer's tolerances							
					A max height	B	C	ϕD max	D	E	S	T
EBV 100-20/90	93	20	145	196.21 x 5.33	902	244	-	561	291.5	255	430	350
EBV 150-20/90	139	20	170		1105	345,5	-	561	373	295	430	350
EBV 200-20/90	207	20	205		1404	465	752	561	600	295	200	120
EBV 300-20/90	293	20	250		1780	522	1128	561	668	295	200	120
EBV 375-20/90	379	20	300		2161	522	1509	561	1049	295	200	120
EBV 475-20/90	473	20	350		2575	522	1923	561	1463	295	200	120
EBV 530-20/90	532	20	380		2834	522	2182	561	1722	295	200	120
EBV 575-20/90	565	20	400		2983	522	2231	561	1871	295	200	120

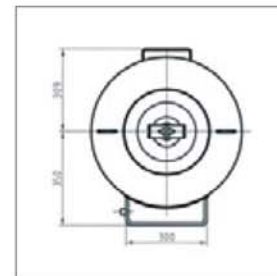
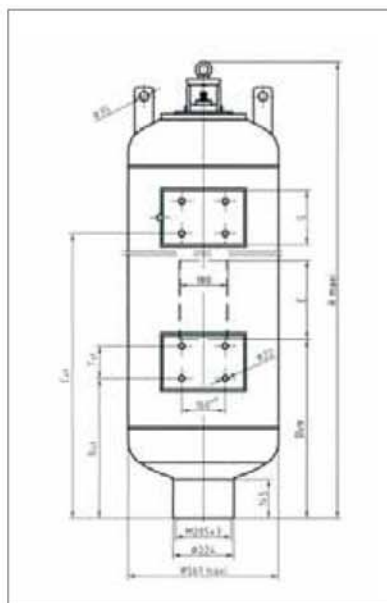
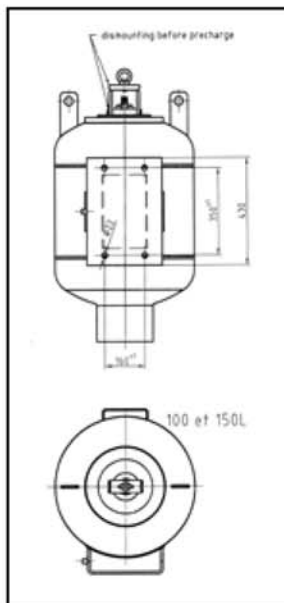

View from the top

The above measurements are given in mm and do not take manufacturing tolerances into consideration.

The Professional Choice

Accessories

CLAMPS

Type	Form	Recom- mended min/max diameter	Dimensions in mm												Recom- mended tightening torque N.m.
			A	B	C		D	E	F	G	H	I	J	K	
					Min	Max									
E95	E	93/97	88	140	61.5	66.5	1.5	28	M8x75	3	40	35	9	155	7
E106	E	99/109	88	140	68	73	1.5	28	M8x75	3	40	35	9	155	7
E114	E	112/124	88	140	73	78	1.5	28	M8x75	3	40	35	9	155	7
E155	E	146/157	137	189	81	86.5	1.7	30	M10x80	3	45	35	9	210	10.5
D215	D	215/219	210	222	123	125	3	36	M12x79	3	40	21	15	266	9
D368	D	368/372	334	346	198.5	201	3	36	M12x75	3	50	21	15	420	11

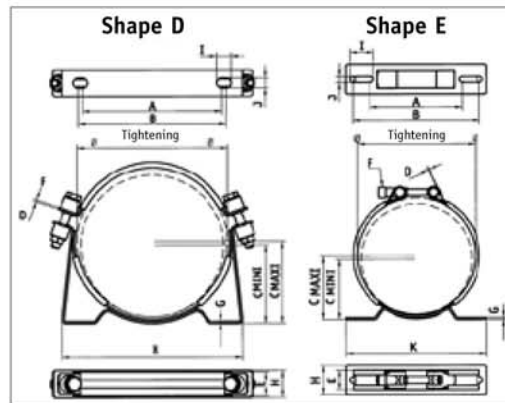

SUPPORT BRACKETS

Type	A	B	C	H	I	J	K	L	M	N	R	Weight
CE 89	89	101	125	73	140	75	13	25	60	75	130	0,7
CE 159	159	170	200	123	235	115	17	25	100	200	260	2,5
C300*	300	-	-	200	380	-	20	50/200	300	375	475	31

* Without rubber part

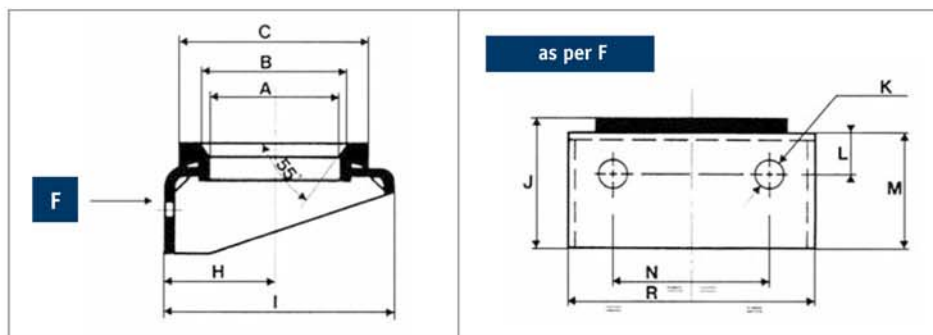

Above dimensions are in mm and are subject to manufacturing tolerances.

FITTINGS

Accumulator model	Connection of accumulator ø F gas cyl.	Connection reducing bush ø I gas cyl.	J/Flats	K	O-Ring
EBV 0,5 to 5 L	2"	1"		13	54 x 3
		Blind	65		
EBV 10 to 50 L	3½"	2"		20	96 x 4
		Blind	112		
EBV 100 to 200 L 40 bar	M 205 x 3	2"		20	196.21 x 5.33
		Blind	2 opposite holes ø 8.5		
Other capacities	Consult Olaer				

FLANGES

Capacity of Accumulator	K
EBV 0.5 to 5 L	13
EBV 10 to 50 L	20
EBV 100 to 200 L 40 Bar	20
Other capacities	Consult Olaer

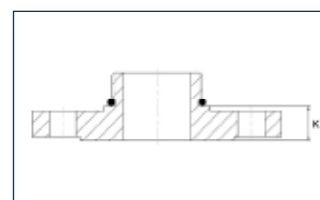
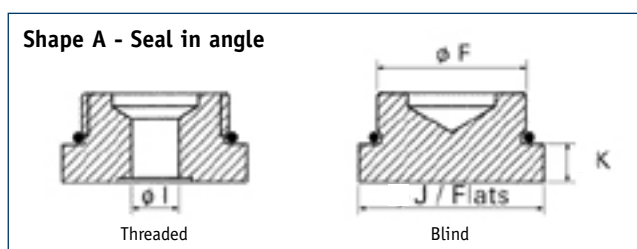

Accessories

Charging sets are used to inflate, check, top-up or vent the nitrogen gas precharge in all accumulators. They are to be screwed to the gas valve or bladder stem and connected to the gas regulator that fits the Nitrogen bottles. They are supplied in a plastic case.

VG3 Model



The standard set is delivered in a storage case containing the following:

- VG3 tester and pressurizer
- Pressure gauge kit from 0 to 60 bar
- 3 connection adapters for inflation valves (7/8"-14 UNF/5/8"-18 UNF/8 V1)
- High pressure hose, 2 m long, for connecting to a nitrogen source. The flexible tube is fitted with a female connector at both ends (60° BSP 1/4" connector for connection to the pressurizing port and connector dia 21,7 x 1,814 SI) with gasket for connection to a pressure source (commercial nitrogen cylinder, portable nitrogen station, superpressurizer, etc.).

Note:

The following options are available on request: Pressure gauge kits with different scale divisions. Scale divisions 0-6, 0-10, 0-60 High pressure hose TS2 for maximum pressure 400 Bar.

Ordering code - Example: VG3 25 1 TS2 1

250 = Gauges, possible choice between pressure ranges 6/10/25/60

TS2 = Flexible hose for maximum working pressure 60 Bar

VGU Model



The standard set is delivered in a storage case containing the following:

- VGU universal tester and pressurizer (end M28x1.50)
- Pressure gauge kit from 0 to 25 bar
- Connection adapters for inflation valves (7/8" - 5/8" - 8V1 - M28x1.50)
- High pressure hose, 2.5 m long, for connecting to a nitrogen source
- Hexagon socket screw key 6mm
- Seal Kit
- Operating instruction in French, English, German

Note:

The following options are available on request: Pressure gauge kits with different scale divisions: 63mm with glycerol filled back end G1/4" cyl. equipped with coupling for Minimes connection. Scale divisions 0-10, 0-60 with accuracy class 1.6%.

High pressure hose of different length with adapters for nitrogen bottles from various countries (specify country), at each end with a female swivel coupling G1/4" for connecting to the inflation port.

Ordering code - Example: VGU/F 0/20 7 TS2 3

25/60 = Gauges, possible choice between pressure ranges 6/10/25/60

How to order?

ORDERING THE EBV ACCUMULATOR

EBV 100-40/90 01180 Po=5b PN40-DN200

Accumulator Range

EBV European low pressure with bladder

Volume

in liters

Maximum working pressure

in Bar

Regulation code

00 : Regulation EC complying 3.3 for the
0.5 L and 1 L volume
90 : Regulation EC for all other volumes

Construction

to be specified as per following recommendations table

Fluid	Operating Temperature °C*	Construction
Mineral oils	-15 + 100	01125
Water	0 + 60	03325
Diesel fuel (Gas Oil)	- 5 + 115	01130
Fuel Oil	-5 + 115	01130
Kerosene	-5 + 115	01130
Gasoline	-5 + 115	01130
Lead free gasoline	-20 + 130	01180
Other fluids	Other temperatures	Please contact Olaer

* Accumulators operation temperature range

Nitrogen gas precharge

in Bar at 20 °C, limited to 20 Bar maximum at the maximum working temperature

Connection to be specified

Blind: with blind connector or with reduction connector (refer to dimension I on the overall dimensions page 9 and specify the connection) or with flange (refer to the eflange line on the dimensions page 9 and specify the type).

ORDERING THE ELG ACCUMULATOR

State the designation of the ELG accumulators mentioned in the table in page 4 "plumbing" (other constructions on request)

Nitrogen gas pressure in bar at 20 °C, limited to 20 bar maximum at maximum working temperature. Refer to the plumbing sector section.

ORDERING ACCESSORIES AND PERIPHERAL MATERIALS

Indicate the designation of accessories mentioned in the tables in pages 8 and 9 and the accessories on page 8.

Item	Spare parts
1	Replacement kit
2*	Complete bladder
3*	Filling valve
4*	Valve plug
5*	Retaining ring
6*	Sealing ring
7*	Perforated bushing

* These parts are delivered in the replacement kit with explanatory notice

HOW TO ORDER THE REPLACEMENT KIT

Example: For an EBV accumulator
100-40/90 01180

KIT EBV 100-40/90 01180

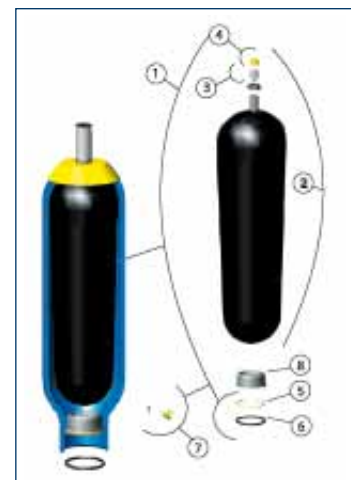

Installation

Position: Preferably vertical (liquid connection downwards) to horizontal, depending upon application. If the accumulator is installed in any position other than vertical with fluid port down, contact Olaer. The accumulator could have reduced volumetric efficiency and Olaer can help you to take these factors into account.

Mounting: A 200mm clearance is required above the accumulator to allow for gas charging. Each accumulator is delivered with a user instructions leaflet. Ensure that the pipes connected directly or indirectly to the accumulator are not subjected to any abnormal force, Ensure that the accumulator cannot move, or minimize any movement that may occur as a result of broken connections. Olaer clamps and brackets are designed for this purpose (and can be supplied as optional extras). The accumulator must not be subjected to any stress or load, in particular from the structure with which it is associated. Contact Olaer in case of mounting on the movable structures.

IT IS STRICTLY FORBIDDEN TO

- Weld, screw or rivet anything onto the accumulator body.
- Operate in any way that may alter the mechanical properties of the accumulator.
- Use the accumulator for construction purposes. (No stress or loading)
- To modify the accumulator without prior approval from the manufacturer.

GAS FILLING

For safety reasons, use only pure nitrogen, minimum 99.8% volume. The pre-charge pressure is less than 20 Bar at the maximum operating temperature or is limited to the pressure of the shell if < 20 Bar. Your local Olaer office can calculate the correct pre-charge pressure for your application. Olaer offers a range of devices for checking nitrogen pressure as well as pre-charging accumulators. Please note that various adaptors are required to interface with different accumulator filling

valves and nitrogen (N₂) cylinder connections throughout the world.

The part number defines the accumulator and the material construction. Information contained on the labeling/ manufacturer's plate:

- Olaer logo
- Product description
- Date or year of manufacture
- Reference information of the accumulator
- Allowable temperature range of the accumulator
-

Additional information on certain models:

- Warning messages and safety instructions ("Danger", "Use nitrogen only" or similar message)
- Maximum inflation pressure P₀ max in bar
- Allowable pressure amplitude P max in bar
- Fluid group (1 or 2 according to the Directive 97/23/EC)
- Total dry mass in kilogram

Regulation CE

Extract from European legislation. Directive 97/23/ EC is applicable from 29-11-1999 and mandatory from 29-05-2002. Decree 99-1046, which applies to new machinery and the ministerial order of 15-03-2000, which applies to the operation of all machinery, transposed the directive into French domestic legislation.

WHAT YOU NEED TO KNOW

Directive 97/23/ EC is applicable from 29-11-1999 and mandatory from 29-05-2002. Decree 99-1046, which applies to new machinery and the ministerial order of 15-03-2000, which applies to the operation of all machinery, transposed the directive into French domestic legislation.

- Free movement of machinery within the European Union.
- Group 2 fluid accumulators whose V ≤ 1 L and PS ≤ 1000 bar are not entitled to bear EC marking.
- The EC marking should be accompanied by the identification number of the notified authority.

EC type accumulators are delivered with instructions for operation and a declaration of conformity. Olaer designs and manufactures hydro-pneumatic accumulators for use in all countries and which comply with national regulations in force as ASME / SELO...



- in Fluid Energy Management

Global perspective

and local entrepreneurial flair



Olaer is a global player specialising in innovative, efficient system solutions for temperature optimisation and energy storage. Olaer develops, manufactures and markets products and systems for a number of different sectors, e.g. the aircraft, engineering, steel and mining industries, as well as for sectors such as oil and gas, contracting and transport, farming and forestry, renewable energy, etc.

All over the world, our products operate in the most diverse environments and applications. One constantly

repeated demand in the market is for optimal energy storage and temperature optimisation. We work at a local level with a whole world as our workplace – local entrepreneurial flair and a global perspective go hand in hand.

Our local presence, long experience and a wealth of knowledge combine with our cutting-edge expertise to give you the best possible conditions for making a professional choice.