

E-M-HC2 Probes-V1_30 <small>Document code</small>	Rotronic AG Bassersdorf, Switzerland <small>Unit</small>
HygroClip 2 (HC2) Humidity Temperature Probes: User Guide <small>Document title</small>	<p style="text-align: right;">Instruction Manual</p> <small>Document Type</small> <hr/> Page 1 of 31

HygroClip 2 (HC2) Humidity Temperature Probes User Guide



E-M-HC2 Probes-V1_30	Rotronic AG Bassersdorf, Switzerland
Document code	Unit
HygroClip 2 (HC2) Humidity Temperature Probes: User Guide	Instruction Manual
	Document Type
Document title	Page 2 of 31

Table of contents

1	Overview	3
1.1	Hardware and software compatibility	3
2	Models	4
3	General description	12
3.1	Power supply.....	12
3.2	Measured parameters	12
3.3	Calculated parameters	12
3.4	Analog output signals.....	12
3.5	Digital interface	13
3.6	Connector	14
3.7	Sensor protection (dust filter)	14
4	User configurable settings and functions	15
4.1	Function overview	15
4.2	Factory default settings	16
5	Mechanical installation	18
5.1	General guidelines for fixed installation.....	18
6	Electrical installation	19
6.1	General guidelines for fixed installation.....	19
6.2	Analog signal wiring	20
6.3	Minimum analog output load	20
6.4	Digital signal wiring	20
6.5	Grounding	20
7	Operation	20
7.1	Operation with an indicator, data logger or transmitter.....	20
7.2	Stand-alone operation as an analog probe	20
7.3	Stand-alone operation as a digital probe (PC or network).....	22
7.4	Connectivity examples for stand-alone probes.....	22
7.5	Hand-held probes used with an indicator	23
8	Maintenance	24
8.1	Cleaning or replacing the dust filter.....	24
8.2	Periodic calibration check	24
8.3	Validation of the output signals transmission	24
9	Firmware updates	25
10	Technical data	26
10.1	Specifications	26
10.2	Dew point accuracy.....	28
10.3	Effect of cable temperature on the accuracy of probes HC2-C04 and HC2-C05	29
11	Accessories and parts	29
12	Supporting documents	30
13	Document releases	31

E-M-HC2 Probes-V1_30	Rotronic AG Bassersdorf, Switzerland
Document code	Unit
HygroClip 2 (HC2) Humidity Temperature Probes: User Guide	Instruction Manual
	Document Type
Document title	Page 3 of 31

Applicability:

This manual applies to all HC2 probes with firmware version 3.0 or higher. Changes to the last digit of the version number reflect minor firmware changes that do not affect the manner in which the probe should be operated.

1 Overview

The HC2 series are digital humidity-temperature probes based on the AirChip 3000 technology. These probes feature a UART serial interface and two 0...1 V linear analog output signals.

The HC2 probes are designed for use with the HygroClip 2 generation of ROTRONIC humidity-temperature instruments: hand-held and bench top indicators, data loggers, transmitters, hygrometers, etc. The HC2 probes maintain all of the benefits of the original HygroClip technology such as the possibility of hot-swapping probes and feature significant improvements in the area of measurement accuracy and functionality.

The HC2 probes can also be used as a stand-alone device using either the analog output signals or the probe digital interface. Connectors, cables and digital interface adapters are available to this purpose. Digital integration with OEM applications is facilitated by the probe communication protocol options.

The HC2 probes offer the following user functions:

- User configurable settings
- Calculation of the dew or frost point
- Humidity temperature calibration and adjustment
- Simulator mode
- Automatic humidity sensor test and drift compensation
- Sensor failure mode
- Data recording

The ability for the user to easily update the AirChip 3000 firmware means that the HC2 probes can be kept up-to-date regarding any future functionality improvement.

Available in different configurations, the HC2 probe series is designed to meet the requirements of a large number of applications and environments.

1.1 *Hardware and software compatibility*

The HC2 probes are compatible only with the AirChip 3000 generation of ROTRONIC humidity-temperature instruments and are not backward compatible with instruments based on the previous technology.

Configuration of the HC2 probes and access to the probe functions requires a PC with the ROTRONIC HW4 software version 2.1.0 or higher or connection to a compatible instrument from ROTRONIC. For firmware updates HW4 software version 3.3.0 or higher is needed.

E-M-HC2 Probes-V1_30	Rotronic AG Bassersdorf, Switzerland
Document code	Unit
HygroClip 2 (HC2) Humidity Temperature Probes: User Guide	Instruction Manual
	Document Type
Document title	Page 4 of 31

2 Models

In the following tables, we have indicated the type of instrument primarily used with each probe model. The following should also be noted:

- The HC2 probes can be directly connected to a PC or to an Ethernet network using one of the available digital interface adapters (see separate document **E-M-HC2-accessories**).
- The HC2 Probes can also be used as a stand alone device with two analog output signals. Different connectors are available to this purpose (see separate document **E-M-HC2-accessories**).

Regardless of the probe model, the analog outputs signals are always scaled in the same way by the factory (0...1 V = 0...100 %RH and 0...1 V = -40...60 °C). The user is responsible for reconfiguring the probe analog outputs (requires the ROTRONIC HW4 software) and for providing power to the probe.

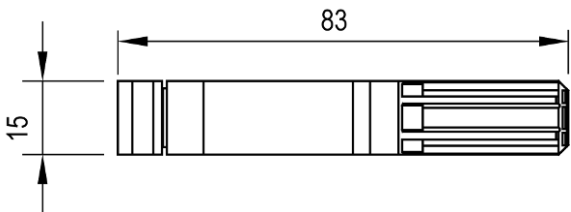
Climate measurement	
<i>For use with indicators, data loggers and transmitters, with or without an extension cable</i>	
HC2-S	Humidity measuring range: 0...100 %RH Temperature limits -50...100 °C (-58...212 °F) Diameter: 15mm (0.6"), length: 85 mm (3.3") Housing and filter cap: polycarbonate, black Standard dust filter: NSP-PCB-PE (Polyethylene) Accurate measurements require full immersion in the environment to be measured Weight: approx. 10 g (0.35 oz)
HC2-S3	Same as HC2-S but with white housing and filter cap for outdoor use
	

E-M-HC2 Probes-V1_30	Rotronic AG Bassersdorf, Switzerland
Document code	Unit
HygroClip 2 (HC2) Humidity Temperature Probes: User Guide	Instruction Manual
	Document Type
Document title	Page 5 of 31

Climate measurement

For use with indicators, data loggers and transmitters, with or without an extension cable

HC2-SM	Humidity measuring range: 0...100 %RH Temperature limits -50...100 °C (-58...212 °F) Diameter: 15mm (0.6"), length: 107 mm (4.3") Housing and filter cap: stainless steel 1.4301 Standard dust filter: SP-M15 (wire mesh, DIN1.4401) Accurate measurements require full immersion in the environment to be measured Weight: approx. 47 g (1.66 oz)
--------	--

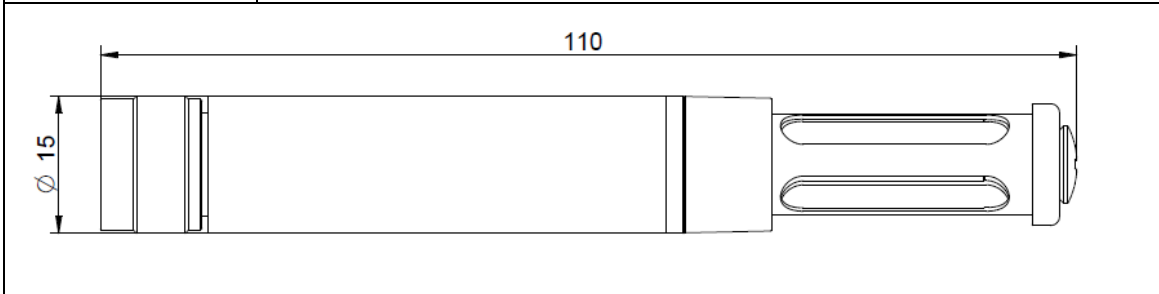

E-M-HC2 Probes-V1_30	Rotronic AG Bassersdorf, Switzerland
Document code	Unit
HygroClip 2 (HC2) Humidity Temperature Probes: User Guide	Instruction Manual
Document title	Document Type
	Page 6 of 31

Measurement in tight spaces	
<i>For use with indicators, data loggers and transmitters</i>	
HC2-C04	Humidity measuring range: 0...100 %RH Temperature limits -40...85 °C (-40...185 °F) Diameter: 4 mm (0.16"), cable length (electronics – probe tip: about 0.59 m (1.9 ft) Probe electronics housing: polycarbonate, black Weight: approx. 150 g (5.3 oz)
HC2-C05	Same as HC2-C04 but with 5 mm diameter (0.2") Can be equipped with Teflon dust filter SP-T05 Weight: approx. 160 g (5.6 oz)

Note: accuracy of the HC2-C04 and HC2-C05 probe models is affected by the temperature of the cable separating the sensors from the electronics (see §10.3).

Spot check measurements in air ducts, chambers and ovens	
<i>Handheld probe for use with indicators and data loggers</i>	
HC2-HK25	Humidity measuring range: 0...100 %RH Temperature limits at sensor -100...150 °C (-148...302 °F) Barrel: diameter: 15 mm (0.6"), length: 250 mm (9.8") Probe cable length: 2 m (6.5 ft) Handgrip: POM, black -, barrel: PEEK, black Filter base (NSP-ME) with wire mesh filter cartridge (SP-M15) Weight: approx. 210 g (7.4 oz)
HC2-HK40	Humidity measuring range: 0...100 %RH Temperature limits at sensor -100...200 °C (-148...392 °F) Same as HC2-HK25 but with barrel 400 mm barrel length (15.7") Weight: approx. 240 g (8.5 oz)

E-M-HC2 Probes-V1_30	Rotronic AG Bassersdorf, Switzerland
Document code	Unit
HygroClip 2 (HC2) Humidity Temperature Probes: User Guide	Instruction Manual
	Document Type
Document title	Page 7 of 31

Measurement of dust-free granular products in bulk	
<i>Handheld probe for use with indicators and data loggers</i>	
HC2-P05	Humidity measuring range: 0...100 %RH Temperature limits -40...85 °C (-40...185 °F) Barrel: diameter: 5 mm (0.2"), length: 200 mm (7.9") Probe cable length: 2 m (6.5 ft) Handgrip: POM, black - barrel: stainless steel DIN 1.4305 Weight: approx. 160 g (5.6 oz)

Measurement of seeds, granulates and powders in bulk	
<i>Handheld probe for use with indicators and data loggers</i>	
HC2-HP28	Humidity measuring range: 0...100 %RH Temperature limits at sensor -40...85 °C (-40...185 °F) Barrel: diameter: 10 mm (0.4"), length: 280 mm (11.0") Probe cable length: 2 m (6.5 ft) Handgrip: POM, black - barrel: stainless steel DIN1.4301 Dust filter: sintered steel filter cartridge (ET-Z10) Weight: approx. 200 g (7.1 oz)
HC2-HP50	Humidity measuring range: 0...100 %RH Same as HC2-HP28 but with barrel 500 mm barrel length (19.7") Weight: approx. 250 g (8.8 oz)

E-M-HC2 Probes-V1_30	Rotronic AG Bassersdorf, Switzerland
Document code	Unit
HygroClip 2 (HC2) Humidity Temperature Probes: User Guide	Instruction Manual
	Document Type
Document title	Page 8 of 31

Measurement of paper – cardboard stacks and rolls	
<i>Handheld probe for use with indicators and data loggers</i>	
HC2-HS28	Humidity measuring range: 0...100 %RH Temperature limits at sensor -40...85 °C (-40...185 °F) Blade: thickness: 4 mm (0.16"), width: 22 mm (0.87"), length: 280 mm (11.0") Probe cable length: 2 m (6.5 ft) Weight: approx. 240 g (8.5 oz) Handgrip: POM, black - blade: aluminum / elox
HC2-HS42	Same as HC2-HS28 but with 420 mm blade length (16.5") Weight: approx. 300 g (10.6 oz)

Measurement of product samples (liquids, pastes, powders, granules or chunks)	
<i>Handheld probe for use with indicators and data loggers</i>	
HC2-AW	Humidity measuring range: 0...100 %RH Temperature limits at sensor -40...85 °C (-40...185 °F) Barrel: aluminum (top) , stainless steel (bottom) Probe cable length: 0.95 m (37.5") Weight: approx. 541 g (1 lb 3.1 oz)
<p>Use together with WP14 or WP-40 sample cup holder</p> <p>Prior to use, verify the integrity and cleanliness of the sealing O-ring located under the probe</p>	

Note:

When using the HC2-AW probe, check that the red LED on top of the probe is lit. This indicates that the probe is being powered. If necessary, power the probe by pressing once on the red button located on top of the probe. When the red LED is not lit, the probe is not powered and the instrument is not receiving a signal from the probe.

E-M-HC2 Probes-V1_30	Rotronic AG Bassersdorf, Switzerland
Document code	Unit
HygroClip 2 (HC2) Humidity Temperature Probes: User Guide	Instruction Manual
	Document Type
Document title	Page 9 of 31

Process measurement (fixed installation)	
For use with transmitters and data loggers	
HC2-IC102 HC2-IC105	Humidity measuring range: 0...100 %RH Temperature limits at sensor -100...200 °C (-148...392 °F) Barrel: diameter: 15 mm (0.6"), length: 100 mm (3.9"). See note below Probe cable length.: 2 m (6.5 ft) or 5 m (16.4 ft) Barrel: PEEK Filter base (NSP-ME). Filter cartridge to be ordered separately Weight: with 2 m cable approx. 230 g (8.1 oz), + 80 g (2.8 oz) per additional meter
HC2-IC302 HC2-IC305	Same as HC2-IC1xx but with 250 mm barrel length(9.8") for through wall installation Weight: with 2 m cable approx. 260 g (9.2 oz), + 80 g (2.8 oz) per additional meter

Note: HC2-IC1 (100 mm barrel length) – to avoid measurement errors due to temperature gradients fully immerse the probe barrel in the environment to be measured

Process measurement (fixed installation)	
For use with transmitters and data loggers	
HC2-IC302-A HC2-IC305-A	Humidity measuring range: 0...100 %RH Temperature limits at sensor -100...200 °C (-148...392 °F) Barrel: diameter: 25 / 15 mm (1.0 / 0.6"), length: 250 mm (9.8") Probe cable length.: 2 m (6.5 ft) or 5 m (16.4 ft) Barrel: PEEK, black Filter base (NSP-ME). Filter cartridge to be ordered separately Designed for through wall installation Weight with 2 m cable: approx. 290 g (10.2 oz), + 80 g (2.8 oz) per additional meter
HC2-IC402-A HC2-IC405-A	Same as HC2-IC3xx-A but with 400 mm barrel length(15.7") Weight with 2 m cable: approx. 320 g (11.3 oz), + 80 g (2.8 oz) per additional meter
HC2-IC502-A HC2-IC505-A	Same as HC2- IC3xx-A but with 550 mm barrel length(21.6") Weight with 2 m cable: approx. 350 g (12.3 oz), + 80 g (2.8 oz) per additional meter
HC2-IC702-A HC2-IC705-A	Same as HC2- IC3xx-A but with 700 mm barrel length(27.5") Weight with 2 m cable: approx. 380 g (13.4 oz), + 80 g (2.8 oz) per additional meter

E-M-HC2 Probes-V1_30	Rotronic AG Bassersdorf, Switzerland
Document code	Unit
HygroClip 2 (HC2) Humidity Temperature Probes: User Guide	Instruction Manual
	Document Type
Document title	Page 10 of 31

Process measurement (fixed installation)	
<i>For use with transmitters and data loggers</i>	
HC2-IM102 HC2-IM105	Humidity measuring range: 0...100 %RH Temperature limits at sensor -100...200 °C (-148...392 °F) Barrel: diameter: 15 mm (0.6"), length: 120 mm (4.7"). See note below Probe cable length.: 2 m (6.5 ft) or 5 m (16.4 ft) Barrel: stainless steel Filter base (SP-MSB15). Filter cartridge to be ordered separately Weight with 2 m cable: approx. 260 g (9.2 oz), + 80 g (2.8 oz) per additional meter
HC2-IM302 HC2-IM305	Same as HC2-IM1xx but with 280 mm barrel length(11.0") for through wall installation Weight with 2 m cable: approx. 400 g (14.1 oz), + 80 g (2.8 oz) per additional meter
HC2-IM402 HC2-IM405	Same as HC2-IM1xx but with 430 mm barrel length(16.9") for through wall installation Weight with 2 m cable: approx. 540 g (19.0 oz), + 80 g (2.8 oz) per additional meter
HC2-IM502 HC2-IM505	Same as HC2-IM1xx but with 580 mm barrel length(22.8") for through wall installation Weight with 2 m cable: approx. 680 g (24.0 oz), + 80 g (2.8 oz) per additional meter
HC2-IM102-M HC2-IM105-M	Humidity measuring range: 0...100 %RH Temperature limits at sensor -100...200 °C (-148...392 °F) Barrel: diameter: 15 mm (0.6"), length: 120 mm (4.7"). See note below Probe cable length.: 2 m (6.5 ft) or 5 m (16.4 ft) Barrel: stainless steel Filter base (SP-MSB15). Filter cartridge to be ordered separately Weight with 2 m cable: approx. 310 g (10.9 oz), + 80 g (2.8 oz) per additional meter
HC2-IM302-M HC2-IM305-M	Same as HC2-IM1xx but with 280 mm barrel length(11.0") for through wall installation Weight with 2 m cable: approx. 450 g (15.9 oz), + 80 g (2.8 oz) per additional meter
HC2-IM402-M HC2-IM405-M	Same as HC2-IM1xx but with 430 mm barrel length(16.9") for through wall installation Weight with 2 m cable: approx. 590 g (20.8 oz), + 80 g (2.8 oz) per additional meter
HC2-IM502-M HC2-IM505-M	Same as HC2-IM1xx but with 580 mm barrel length(22.8") for through wall installation Weight with 2 m cable: approx. 730 g (25.7 oz), + 80 g (2.8 oz) per additional meter
<p>The diagram shows a side view of the probe barrel. It consists of a main section with a diameter of 15 mm and a length of 103 mm. This is followed by a section with a diameter of 39 mm and a length of 120, 280, 430, or 580 mm, depending on the model. The 39 mm diameter section has a length of 39 mm at its end.</p>	

Note 1:

HC2-IMxxx-M probes are the same as HC2-IMxxx but are equipped with a stainless steel connector instead of PPS.

Note 2:

HC2-IM102 (120 mm barrel length) - to avoid measurement errors due to temperature gradients fully immerse the probe barrel in the environment to be measured.

E-M-HC2 Probes-V1_30	Rotronic AG Bassersdorf, Switzerland
Document code	Unit
HygroClip 2 (HC2) Humidity Temperature Probes: User Guide	Instruction Manual
	Document Type
Document title	Page 11 of 31

Measurement in compressed air conduits and vessels (fixed installation)	
<i>For use with transmitters and data loggers</i>	
HC2-IE102 HC2-IE105	Humidity measuring range: 0...100 %RH Temperature limits at sensor -100...200 °C (-148...392 °F) G ½" thread for maximum 100 bar / 1450 PSI Probe cable length.: 2 m (6.5 ft) or 5 m (16.4 ft) Barrel: stainless steel Filter base (SP-MSB15). Filter cartridge to be ordered separately Weight with 2 m cable: approx. 290 g (10.2 oz), + 80 g (2.8 oz) per additional meter
HC2-IE302 HC2-IE305	Humidity measuring range: 0...100 %RH Temperature limits at sensor -100...200 °C (-148...392 °F) NPT ½" thread for maximum 100 bar / 1450 PSI Probe cable length.: 2 m (6.5 ft) or 5 m (16.4 ft) Barrel: stainless steel Filter base (SP-MSB15). Filter cartridge to be ordered separately (see Accessories) Weight with 2 m cable: approx. 290 g (10.2 oz), + 80 g (2.8 oz) per additional meter
HC2-IE102-M HC2-IE105-M	Humidity measuring range: 0...100 %RH Temperature limits at sensor -100...200 °C (-148...392 °F) G ½" thread for maximum 100 bar / 1450 PSI Probe cable length.: 2 m (6.5 ft) or 5 m (16.4 ft) Barrel: stainless steel Filter base (SP-MSB15). Filter cartridge to be ordered separately Weight with 2 m cable: approx. 340 g (12.0 oz), + 80 g (2.8 oz) per additional meter
HC2-IE302-M HC2-IE305-M	Humidity measuring range: 0...100 %RH Temperature limits at sensor -100...200 °C (-148...392 °F) NPT ½" thread for maximum 100 bar / 1450 PSI Probe cable length.: 2 m (6.5 ft) or 5 m (16.4 ft) Barrel: stainless steel Filter base (SP-MSB15). Filter cartridge to be ordered separately (see Accessories) Weight with 2 m cable: approx. 340 g (12.0 oz), + 80 g (2.8 oz) per additional meter

Note 1:

HC2-IExxx-M probes are the same as HC2-IExxx but are equipped with a stainless steel connector instead of PPS.

Note 2:

To avoid measurement errors, temperature should be the same on both sides of the mounting wall

E-M-HC2 Probes-V1_30	Rotronic AG Bassersdorf, Switzerland
Document code	Unit
HygroClip 2 (HC2) Humidity Temperature Probes: User Guide	Instruction Manual
	Document Type
Document title	Page 12 of 31

General description

3 General description

3.1 Power supply

The accuracy specified for the HC2 probes is valid only when the probe is supplied with a voltage within the range of 3.3...5 VDC. The probes are tested and adjusted at the factory using a supply voltage of 3.3 VDC.

When a voltage source of 3.3...5 VDC is not available, the probe should be used together with a voltage adapter (see separate document **E-M-HC2-accessories**) so as to provide 3.3...5 VDC to the probe. Use of a voltage adapter allows powering the probe from a voltage source of 5 to 24 VDC or 5 to 16 VAC.

During start-up the typical current consumption of the probe is initially 8 mA during 2ms and 5 mA during the next 2s. Without a power supply limiter, the start-up current may reach a maximum of 50 mA. After start-up the current consumption is on average less than 3 mA. Randomly distributed current spikes of maximum 1 mA during 2µs are normal during operation and are caused by the probe micro-processor and associated components.

The HC2 probes are polarity protected by a keyed connector. There is no electrical polarity protection.

3.2 Measured parameters

The HC2 probe measures relative humidity with a ROTRONIC Hygromer® IN1 capacitive sensor and temperature with a Pt100 RTD.

3.3 Calculated parameters

Using the ROTRONIC HW4 software, the HC2 probe can be configured by the user to calculate either the dew point or the frost point.

3.4 Analog output signals

The HC2 probe features two 0...1 V linear analog output signals. The default factory settings are as follows:

Output 1: 0...1 V (humidity) = 0...100 %RH
Output 2: 0...1 V (temperature) = -40...60°C

Using the ROTRONIC HW4 software any output signal can be made to correspond one of the following:

- Relative humidity
- Temperature
- Dew or frost point

The scale of each analog output can be set within the numerical limits of -999.99 and 9999.99. If so desired, any output can also be disabled (no signal).

The D/A converters used to generate the analog output signals feature a 16-bit resolution. The 0...1 V analog output signals exhibit a small positive offset of 3 mV or less at 0 V.

Minimum load requirements apply to the external device or circuit connected to the probe voltage outputs. These requirements are defined in the "Operation" chapter

Note: users who require an analog signal other than 0...1 V should either contact ROTRONIC or connect the probe to one of the available transmitters.

E-M-HC2 Probes-V1_30	Rotronic AG Bassersdorf, Switzerland
Document code	Unit
HygroClip 2 (HC2) Humidity Temperature Probes: User Guide	Instruction Manual
	Document Type
Document title	Page 13 of 31

3.5 *Digital interface*

The HC2 probe features a UART interface (Universal Asynchronous Receiver Transmitter) that allows two-way communication with the probe. For connecting the HC2 probe to a PC, use any of the following digital adapter cables AC3001, AC3002 or AC3005 (see document **E-M-HC2-accessories**). The probe can also be indirectly connected to a PC using an instrument from the ROTRONIC program.

The ROTRONIC HW4 software (version 2.1.0 or higher) allows full access to the following:

- Measurement data (humidity and temperature) and calculated parameter (dew or frost point)
- Probe information: name, RS-485 address, humidity sensor status, etc.
- Probe alarm functions
- Probe data logging function
- Probe calibration and probe adjustment functions
- Probe configuration

The ROTRONIC HW4 software (version 3.3.0 or higher) allows full access to the following:

- Firmware update of HygroClip probes

Communication protocol options

The probe measurement data can be read without having to use the ROTRONIC HW4 software. Starting with firmware version 1.3, the HC2 probe offers the following communication protocol options (ASCII) which can be selected by connecting the probe to a PC running the ROTRONIC HW4 software (version 2.1.1 or higher):

- **RO-ASCII:** this is the standard (default) communication protocol used by all AirChip 3000 devices and by the HW4 software. In principle, this protocol supports all of the AirChip 3000 functions but some of the functions require a certain amount of computations to be carried out by an external device such as a PC.
- **Custom:** this communication protocol can be used to provide compatibility of the HC2 probe with an existing communication system. The Custom communication protocol is limited to reading measurement data from the HC2 probe. Functions such as device configuration, humidity and temperature adjustment, etc. are not supported. The Custom protocol is applicable to all AirChip 3000 devices with a digital interface and allows RS-485 networking
- **I2C:** The I2C protocol available with the HC2 probe does not allow the networking of devices and is limited to a one way communication where the HC2 probe automatically sends data during each refresh interval to an external device with I2C input.

When using either the RO-ASCII or the Custom protocol, the HC2 probe can be set to send data automatically after each refresh cycle without requiring a data request. When this mode is enabled, the receiving device must be listening at all times in order to get the measurement data.

For details, see document **E-M-AC3000-CP**

E-M-HC2 Probes-V1_30	Rotronic AG Bassersdorf, Switzerland
Document code	Unit
HygroClip 2 (HC2) Humidity Temperature Probes: User Guide	Instruction Manual
	Document Type
Document title	Page 14 of 31

3.6 Connector

All standard probe models of the HC2 series use the same keyed connector (male). The connector is located either directly on the probe body or at the end of a cable. The probe connector is secured to the matching female connector with a threaded collar.

Pin-out diagram

Probe connector (7-pin male – looking at probe)

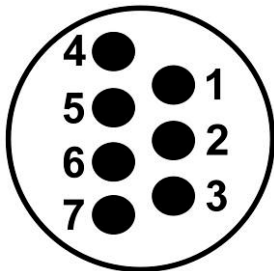

Pin #	Wire Color	Name	Function
1	Green	VDD (+)	3.3 to 5 VDC
2	Grey	GND	Power and digital signal
3	Red	RXD	UART
4	Blue	TXD	UART
5	White	Out 1 analog (+)	Humidity 0...100%RH (default)
6	Brown	Out 2 analog (+)	Temperature -40...60°C (default)
7	Yellow	AGND	Analog signal ground

3.7 Sensor protection (dust filter)

Most probes of the HC2 series are supplied with a filter to protect the sensors against dust particles and high air velocity. Depending on the probe model the following types of filter materials are used:

Material	Maximum temperature	Notes
Polyethylene	100 °C (212 °F)	Recommended filter material for all applications below 100 °C. Good response and good protection against fine dust particles. No water absorption or retention
Teflon	200 °C (392 °F)	Good protection against fine dust particles and salt (marine environments). Moderately slow response
Stainless steel wire mesh	200 °C (392 °F)	Provides fastest response time. Not recommended in environments with fine dust particles (clogging) and in bioactive environments
Stainless steel sintered filter	200 °C (392 °F)	Good response at low humidity levels. Do not use at high humidity levels. Provides best protection against abrasive particles

Note: Depending on the probe model, the dust filter is either automatically included with the probe or it must be ordered separately (see Models).

E-M-HC2 Probes-V1_30 Document code	Rotronic AG Bassersdorf, Switzerland Unit
HygroClip 2 (HC2) Humidity Temperature Probes: User Guide Document title	Instruction Manual Document Type
	Page 15 of 31

4 User configurable settings and functions

The HC2 probe ships configured as per the factory defaults:

- Users who intend to use the probe as a stand-alone analog device can use the probe as any conventional humidity and temperature probe. A connecting cable with active electronics may be required to power the probe. Most such users will never have to use the probe configurable settings and functions
- Users who purchased a probe for use with another ROTRONIC instrument can also use the probe right away and do not necessarily have to use the probe configurable settings and functions
- Users that intend to use the probe as a stand-alone digital device typically need to use a connecting cable with active electronics and generally need to configure either the probe or the PC

Making use of the probe configurable settings and functions is entirely up to the user and the appropriate settings depend on the user application. We have provided below a short description of the probe functions and also indicated the factory default settings.

4.1 Function overview

MEASUREMENT ACCURACY AND RELIABILITY	
AirChip 3000 Functions	Description
▶ Humidity / temperature adjustment	<ul style="list-style-type: none"> ○ 1-point or multi-point humidity calibration or adjustment ○ 1-point or 2-point temperature calibration or adjustment ○ Generate a time stamp for calibrations and adjustments ○ Retain and view last adjustment date and adjustment values ○ Generate calibration and adjustment protocols
▶ Automatic humidity sensor test and optional drift compensation	<p>Tests the humidity sensor for drift caused by contaminants and can be used to automatically apply a correction. The test is automatically carried out at regular intervals of time. Can be configured, enabled, or disabled</p> <p>The humidity sensor status can be verified either with the HW4 software and is shown as Good, SQ-tuned (corrected for drift) or Bad (defective)</p>
▶ Data recording	<p>The data recording function differs from a true data logging function in the sense that the AirChip 3000 does not time stamp the data. This data recording function can be used to investigate events such as a sensor malfunction as well as to retrieve data that would otherwise be lost</p> <ul style="list-style-type: none"> ○ Start or stop data recording - up to 2000 value pairs (%RH and temperature). Starting a recording session erases all previously recorded data ○ The recording mode and log interval can be specified ○ When the probe is powered off, the recording session is paused but not ended. As long as the recording session has not been ended, the probe automatically resumes recording data when powered up again ○ The recorded data can be downloaded to a PC with the HW4 software, time stamped and viewed

E-M-HC2 Probes-V1_30	Rotronic AG Bassersdorf, Switzerland
Document code	Unit
HygroClip 2 (HC2) Humidity Temperature Probes: User Guide	Instruction Manual
	Document Type
Document title	Page 16 of 31

MEASUREMENT LOOP VALIDATION

AirChip 3000 Functions	Description
▶ Simulator mode	Used to make the probe generate fixed values for the humidity, temperature and calculated parameter. Can be configured, enabled or disabled

SAFEGUARDS

AirChip 3000 Functions	Description
▶ Device write protection	Used to protect the probe with a password to prevent unauthorized digital access by a digital user. Can be configured, enabled or disabled

PROCESS PROTECTION / PROTECTION OF OTHER DEVICES

AirChip 3000 Functions	Description
▶ Limit humidity output to 100 %RH	Used to prevent the humidity signal from exceeding 100 %RH when condensation forms on the sensor. Can be enabled or disabled
▶ Out-of-limit value alarm	Used to specify the normal range for humidity, temperature and the calculated parameter depending on the user application. Can be configured, enabled or disabled Out-of-limit values trigger a digital alarm
▶ Bad sensor alarm	Built-in function. Cannot be disabled A bad humidity or temperature sensor triggers a digital alarm
▶ Fail safe mode	Used to specify a "safe" fixed value for humidity and for temperature in the event of a sensor failure. Can be configured, enabled or disabled

4.2 Factory default settings

Note: Configuration of the probe by the user and access to its functions requires a PC with the ROTRONIC HW4 software (version 2.1.1 or higher) installed. For connecting the HC2 probe to a PC, use any of the following digital adapter cables AC3001, AC3002 or AC3005 (see document **E-M-HC2-accessories**).

Configurable Settings	Factory default
Unit system (Metric or English)	Metric
Psychrometric calculation	None
Output 1 parameter, scale and unit	Humidity: 0...100%RH
Output 2 parameter, scale and unit	Temperature: -40...60 °C
Communication protocol	RO-ASCII
RS-485 address	0
Device name	Probe type

E-M-HC2 Probes-V1_30	Rotronic AG Bassersdorf, Switzerland
Document code	Unit
HygroClip 2 (HC2) Humidity Temperature Probes: User Guide	Instruction Manual
	Document Type
Document title	Page 17 of 31

Functions	Factory default
Humidity / temperature adjustment	Enabling / Disabling only by HW4 user rights possible
Device write protection	Disabled
Limit humidity output to 100 %RH	Enabled
Out-of-limit value digital alarm	Disabled
Data recording	Disabled
Automatic humidity sensor test	Disabled
Humidity sensor drift compensation	Disabled
Fail safe mode	Disabled
Simulator mode	Disabled

- For a detailed description of all AirChip 3000 / probe main functions see document **E-T-AC3000-DF-V1**
- Instructions regarding the configuration of the probe and access to its functions are provided in the following manuals:

E-M-HW4v3-Main
E-M-HW4v3-F2-001
E-M-HW4v3-DR-001
E-M-HW4v3-A2-001
E-M-AC3000-CP

E-M-HC2 Probes-V1_30	Rotronic AG Bassersdorf, Switzerland
Document code	Unit
HygroClip 2 (HC2) Humidity Temperature Probes: User Guide	Instruction Manual
	Document Type
Document title	Page 18 of 31

5 Mechanical installation

Note: the following instructions apply only to the situation where the HC2 probe is fixed installed.

5.1 General guidelines for fixed installation

For best results, please observe the following guidelines:

- Install the probe at a location where humidity, temperature and pressure conditions are representative of the environment or process to be measured. Avoid the following: (a) Close proximity of the probe to a heating element, a cooling coil, a cold or hot wall, direct exposure to sun rays, etc. (b) Close proximity of the probe to a steam injector, humidifier, direct exposure to precipitation, etc. (c) Unstable pressure conditions resulting from excessive air turbulence.
- When installing the probe on a wall, do not place the probe right above a heat producing device of instrument such as a transmitter or an Ethernet adapter (warm air tends to rise).
- If possible, choose a location that provides good air movement at the probe: air velocity of at least 1 meter/second (200 ft/ minute) facilitates adaptation of the probe to changing temperature.
- When installing the probe through a wall, immerse as much of the probe as possible in the environment to be measured.

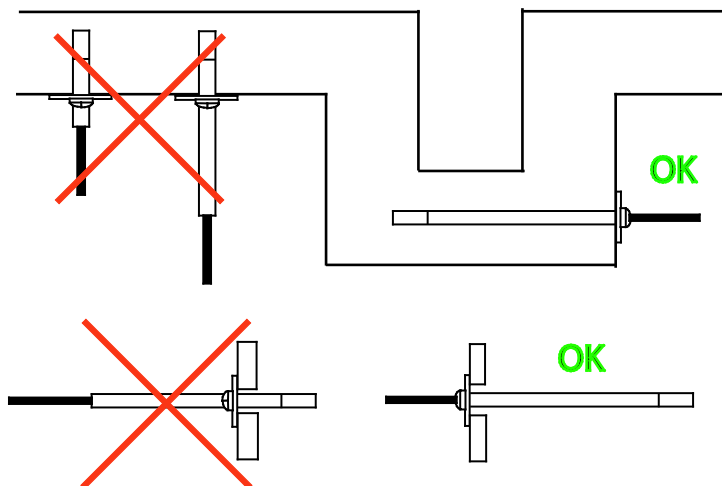

Position the probe so as to prevent the accumulation of condensation water at the level of the sensor leads. Install the probe so that the probe tip is looking downward. If this is not possible, install the probe horizontally.

Depending on the probe model, a probe holder (mounting flange with a compression fitting) can facilitate installation through a wall.

Future maintenance can be made easier by providing next to the probe a calibration access orifice. During maintenance, this permits the insertion of a reference probe (calibrator). The calibration access orifice should have the same size as the orifice used to install the probe and can be equipped with a probe holder.

E-M-HC2 Probes-V1_30	Rotronic AG Bassersdorf, Switzerland
Document code	Unit
HygroClip 2 (HC2) Humidity Temperature Probes: User Guide	Instruction Manual
	Document Type
Document title	Page 19 of 31

6 Electrical installation

Note: the following instructions apply only to the situation where the HC2 probe is fixed installed.

6.1 General guidelines for fixed installation

Power supply wiring

Heavy machinery and instrumentation should not share the same power supply wiring. If this cannot be avoided, noise filters and surge protectors should be used. Most UPS devices have those features already integrated.

General guidelines for signal cables

The following guidelines are derived from European Standard EN 50170 for the transmission of signals by copper wires. When planning an installation, the rules provided by EN 50170 should be followed under consideration of local circumstances to determine the position of machines and equipment.

All ROTRONIC HygroClip products are tested for Electromagnetic Compatibility according to EMC Directive 2004/106/EG and following European standards:

- EN 61000-6-1: 2001, EN 61000-6-2: 2005
- EN 61000-6-3: 2005, EN 61000-6-4: 2001 + A11

Whenever the level of electromagnetic interference is expected to be high, both the instruments and signal cables should be placed as far away as possible from the source of interference.

In general, signal cables should be installed in bundles or channels / conduits, separate from other cables as indicated in the table below:

<ul style="list-style-type: none"> • Bus signals such as RS485 • Data signals for PCs, printers etc. • shielded analog inputs • unshielded direct current (<= 60V) • shielded process signals (<= 25 V) • unshielded alternate current (<= 25V) • coaxial cables for CRT monitors 	in common bundles or channels / conduits
<ul style="list-style-type: none"> • direct current from 60 V to 400 V (unshielded) • alternate current from 25V to 400 V (unshielded) 	in separated bundles or channels / conduits, without minimum distance
<ul style="list-style-type: none"> • direct and alternate current > 400 V (unshielded) • Telephone lines • lines leading into EX-rated areas 	in separated bundles or channels / conduits, without minimum distance

E-M-HC2 Probes-V1_30	Rotronic AG Bassersdorf, Switzerland
Document code	Unit
HygroClip 2 (HC2) Humidity Temperature Probes: User Guide	Instruction Manual
	Document Type
Document title	Page 20 of 31

Lightning protection

Cabling in areas with a risk of lightning requires a lightning protection. For cabling underground in between buildings, we recommend the use of special fiber optic cables. If this is not possible, use copper cables that are suitable for underground installation.

6.2 *Analog signal wiring*

Preferably use a shielded cable to connect the analog outputs of the HC2 to other devices. The maximum cable length is determined by the maximum error that the user will accept. This can be calculated as follows:

Error (V) = cable resistance x current through load

6.3 *Minimum analog output load*

The HC2 analog outputs are short circuit tolerant and have an internal resistance of less than 10 Ω. For proper operation, the minimum external load of each output should be at least 1000 Ω.

6.4 *Digital signal wiring*

Use one of the available connecting cables (see Accessories) to connect the UART digital interface of the HC2 probe to other devices. Without a signal booster, the maximum cable length should not exceed 5 m (16 ft).

6.5 *Grounding*

In the case of a fixed installation, ground the HC2 probe, especially if the electronics will be subjected to a low humidity environment (35 %RH or less). The power supply and digital ground (GND) and the analog ground (AGND) should be tied separately to a proper ground so as to avoid spikes in the analog signals.

7 *Operation*

7.1 *Operation with an indicator, data logger or transmitter*

The HC2 probes are compatible with a large number of indicators, data loggers and transmitters from ROTRONIC. Operating instructions are provided in each device manual.

7.2 *Stand-alone operation as an analog probe*

The HC2 probes can be used as a conventional analog probe. See Accessories, supply voltage adapters, connectors and cables. Use the HW4 software to configure the probe as desired, complete the mechanical and electrical installation and power up the probe.

E-M-HC2 Probes-V1_30	Rotronic AG Bassersdorf, Switzerland
Document code	Unit
HygroClip 2 (HC2) Humidity Temperature Probes: User Guide	Instruction Manual
	Document Type
Document title	Page 21 of 31

7.2.1 Minimum load requirements for the probe voltage outputs

The following requirements apply to any external device or circuit connected to the probe voltage outputs:

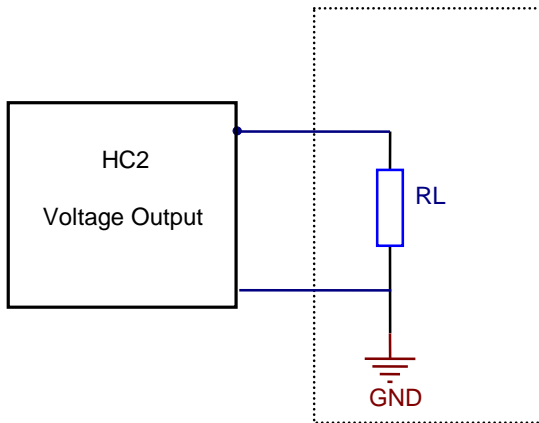

HFC2 output signal	Input resistance RL
0...1V	$\geq 1\text{k}\Omega$

In the situation where the external device uses an internal pull-up resistor the value of this resistor should meet the requirements shown below. It is also necessary to add a pull-down resistor RL connected to ground in order to be able to read 100% of the range of the probe voltage output.

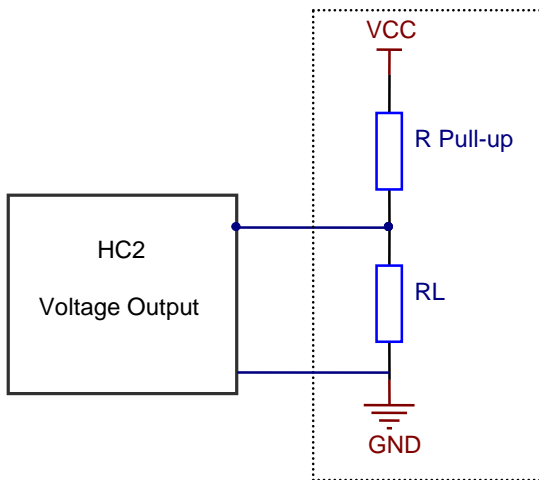

HC2 signal	VCC	R pull-up	RL
0...1V	3.3V	$\geq 250\text{ k}\Omega$	1 k Ω

HC2 signal	VCC	R pull-up	RL
0...1V	5.0V	$\geq 400\text{ k}\Omega$	1 k Ω

HC2 signal	VCC	R pull-up	RL
0...1V	10.0V	$\geq 1\text{ M}\Omega$	1 k Ω

E-M-HC2 Probes-V1_30	Rotronic AG Bassersdorf, Switzerland
Document code	Unit
HygroClip 2 (HC2) Humidity Temperature Probes: User Guide	Instruction Manual
	Document Type
Document title	Page 22 of 31

7.3 Stand-alone operation as a digital probe (PC or network)

The HC2 probes can be connected to a PC or to an Ethernet network with one of the available digital interface adapters (see Accessories). Probe configuration and full access to all probe functions requires a PC with the ROTRONIC HW4 software installed. Starting with firmware version 1.3, the probes accept several communication protocols that allow users to read the measurement data without the HW4 software. When using the standard RO-ASCII protocol, access to some of the probe functions is also possible without HW4. For details, see document **E-M-AC3000-CP**.

7.4 Connectivity examples for stand-alone probes

Digital connection example: RS-485 network

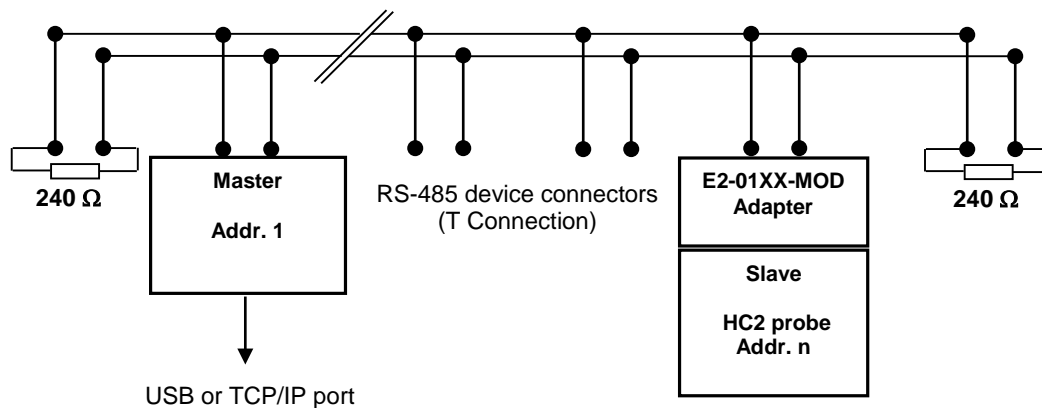

Notes:

- The master device can be either a transmitter such as the HF5 (USB or TCP/IP interface) or an adapter such as the AC3010 cable (USB)
- Power to the combination E2-01XX-MOD and HC2 probe can be provided by an individual AC adapter or by a central voltage source connected to the RS-485 network (requires cables with 2 twisted pairs: one for the data, the other for power)

E-M-HC2 Probes-V1_30 Document code	Rotronic AG Bassersdorf, Switzerland Unit
HygroClip 2 (HC2) Humidity Temperature Probes: User Guide Document title	Instruction Manual Document Type
	Page 23 of 31

Analog connection example:

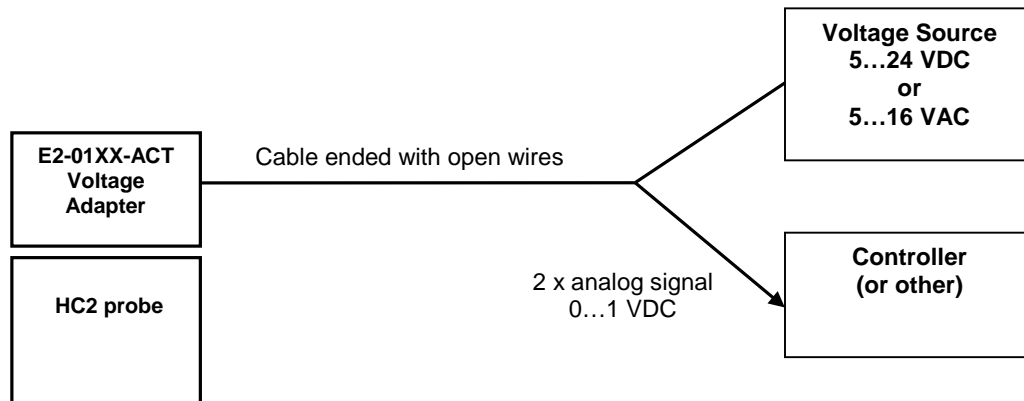

7.5 Hand-held probes used with an indicator

The most common source of error when measuring relative humidity with a hand-held probe is a difference between the temperature of the probe and the temperature of the environment. At a humidity condition of 50 %RH, a temperature difference of 1°C (1.8 °F) typically results in an error of 3 %RH on relative humidity.

When using a humidity probe with a portable indicator, it is good practice to monitor the display for temperature stability. When moving the probe from one area to another, the probe should be given sufficient time to equilibrate with the environment to be measured. This time can be shortened, and errors avoided, by using the probe configuration that fits best for your application.

In extreme situations, condensation may occur on the sensors when the probe is colder than the environment. As long as the humidity / temperature limits of the humidity sensor are not exceeded, condensation does not alter the calibration of the sensor. However, the sensor has to dry out before it can provide a valid measurement.

Non-moving air is an excellent insulator. When there is no air movement, surprising differences in temperature and humidity can be noted over short distances. Air movement at the probe generally results in measurements that are both faster and more accurate.

E-M-HC2 Probes-V1_30	Rotronic AG Bassersdorf, Switzerland
Document code	Unit
HygroClip 2 (HC2) Humidity Temperature Probes: User Guide	Instruction Manual
	Document Type
Document title	Page 24 of 31

8 Maintenance

8.1 *Cleaning or replacing the dust filter*

Depending on the conditions of measurement, the filter should be checked from time to time. Corroded, discolored or clogged filters should be replaced.

- If the probe has a removable cartridge, simply replace the cartridge (leave the metal base on the probe).

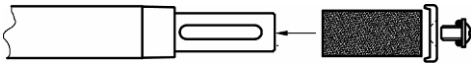

- If the probe has a plastic slotted cap with a built-in filter element follow these instructions:
 - 1) Unscrew the filter from the probe and pull it straight away, in the alignment of the probe, so as not to catch the humidity and temperature sensors.
 - 2) Before putting on a new dust filter, check the alignment of both sensors with the probe. The wires that connect the sensors to the probe are very thin and bend easily. If necessary, correct the alignment by tapping the sensor very gently with a smooth object such as a small plastic rod. Do not use sharp pliers or tweezers as this could puncture the sensor and do not pull hard on the sensor.

8.2 *Periodic calibration check*

Both the Pt 100 RTD temperature sensor and associated electronics are very stable and should not require any calibration after the initial factory adjustment.

Long term stability of the ROTRONIC Hygromer humidity sensor is typically better than 1 %RH per year. For maximum accuracy, calibration of the probe should be verified every 6 to 12 months. Applications where the probe is exposed to contaminants may require more frequent verifications. Calibration and adjustment of the HC2 probe can be done with either a PC with the HW4 software installed (version 2.1.0 or higher) or with the HP23 hand-held calibrator. For connecting the HC2 probe to a PC, use any of the following digital adapter cables AC3001, AC3002 or AC3005 (see document **E-M-HC2-accessories**).

Procedure for adjusting the HC2 probe with the ROTRONIC HW4 software:

- Connect the HC2 probe to the HW4 PC as explained in the HW4 manual **E-M-HW4v3-Main**
- Start HW4 software on the PC and search for the HC2 probe. (HW4 Main Menu Bar > Devices and Groups > Search for USB masters or Search for RS232 masters or search for Ethernet masters, depending on the connecting cable).
- After finding the HC2 probe with HW4, expand the device tree to see the HC2 probe functions and select **Probe Adjustment**.
- For further instructions see HW4 manual **E-M-HW4v3-A2-001**

8.3 *Validation of the output signals transmission*

If so desired, transmission of the HC2 probe output signals can be validated by using the probe simulator function. The HW4 software is required to enable and configure this function. When the function is enabled the probe generates digital and analog signals corresponding to values specified by the user.

E-M-HC2 Probes-V1_30 Document code	Rotronic AG Bassersdorf, Switzerland Unit
HygroClip 2 (HC2) Humidity Temperature Probes: User Guide Document title	Instruction Manual Document Type
	Page 25 of 31

9 Firmware updates

Firmware updates will be available on the ROTRONIC website for downloading. Firmware files are given a name that shows both to which device the file applies and the version number of the firmware. All firmware files have the extension HEX. For connecting the HC2 probe to a PC, use any of the following digital adapter cables AC3001, AC3002 or AC3005 (see document **E-M-HC2-accessories**).

Procedure for updating the firmware:

- Connect the HC2 probe to the HW4 PC as explained in the HW4 manual **E-M-HW4v3-Main**
- Copy the firmware update file from the ROTRONIC website to the PC.
- Start HW4 software on the PC and search for the HC2 probe. (HW4 Main Menu Bar > Devices and Groups > Search for USB masters or Search for RS232 masters or search for Ethernet masters, depending on the connecting cable).
- After finding the HC2 probe, expand the device tree to see the HC2 probe functions. Select Device Manager. In the Device Manager menu bar select Tools > Firmware Update. For instructions see document **E-M-HW4v3-F2-001**

E-M-HC2 Probes-V1_30	Rotronic AG Bassersdorf, Switzerland
Document code	Unit
HygroClip 2 (HC2) Humidity Temperature Probes: User Guide	Instruction Manual
Document title	Document Type
	Page 26 of 31

10 Technical data

10.1 Specifications

General	
Device type	Humidity temperature probe
Mechanical configuration	See models
IP protection class	IP65

Power supply and connections	
Supply voltage (VDD)	3.3 ... 5 VDC \pm 0%
Recommended supply voltage	3.3 VDC
Supply voltage during factory tests and adjustment	3.3 VDC
Supply voltage stability / ripple	See System Accuracy, effect of VDD
Nominal current consumption	<4.5 mA at VDD = 3.3...5 VDC
Maximum start-up current unlimited	<50mA during 2 μ s
Minimum start-up current	8 mA during 2ms and 5 mA during 2s
Maximum current spike during operation	1 mA during maximum 2 μ s
Polarity protection	Mechanical only (keyed connector)

Humidity measurement	
Sensor	ROTRONIC Hygromer [®] IN1
Measuring range	0...100 %RH
Measurement accuracy	\pm 0.8 %RH, at 10...30 °C (HC2-S(3), HC2-IC, HC2-IM, HC2-IE) \pm 0.5 %RH, at 10...30 °C / 10..90 %RH (HC2-S(3)H) \pm 1.5 %RH (HC2-C04, HC2-C05; see also §10.3)
Repeatability	0.3 %RH
Long term stability	<1 %RH / year
Sensor time constant	Typical 10 sec, 63% of a 35 to 80 %RH step change (1m/sec air flow at sensor)

Temperature measurement	
Sensor	Pt100 RTD, IEC 751 class A (HC2-S) Pt100 RTD, IEC 751 1/3 class B (HC2-IC / HC2-IM / HC2-IE)
Measuring range	-100...200 °C (see also environmental limits)
Measurement accuracy	\pm 0.1 °C, at 10...30 °C \pm 0.3 °C, at 10...30 °C (HC2-C04, HC2-C05; see also §10.3)
Repeatability	0.05 °C
Long term stability	<0.1 °C / year
Sensor time constant	Typical 4 sec, 63 %RH of a step change (1 m/sec air flow at sensor)

Calculated parameters	
Psychrometric calculations	Dew or frost point (user configurable)

Start-up time and data refresh rate	
Start-up time	1.5 s (typical)
Data refresh rate	1.0 s (typical) – when not calculating any parameter

E-M-HC2 Probes-V1_30	Rotronic AG Bassersdorf, Switzerland
Document code	Unit
HygroClip 2 (HC2) Humidity Temperature Probes: User Guide	Instruction Manual
Document title	Document Type
	Page 27 of 31

Configurable analog outputs	
Output 1	Can be made to correspond to any parameter
Factory default parameter	Relative humidity
Factory default scale	0...100 %RH
Output 2	Can be made to correspond to any parameter
Factory default parameter	Temperature
Factory default scale	-40...60 °C
Output 1 and Output 2	
Signal type	0...1 V
User configurable scaling limits	-999.99 ... 9999.99 engineering units
Offset at 0 V	+ 3 mV (maximum)
Ripple	<1.2 mV/x 2µs
Short circuit tolerant	Yes
Internal resistance	<10 Ω
Minimum external load	1000 Ω
Deviation from digital signal	<±1 mV from 0.002 to 1.0 V / + 2 mV from 0.0 to 0.002 V

Digital interface	
Interface type	UART (Universal Asynchronous Receiver Transmitter)
Organization	Dialog, duplex
Default configuration	Baud rate : 19200 Parity : none Data bits : 8 Stop bits : 1 Flow Control : none
Tolerance	3 %
Baud rate configuration:	No
Logical levels	Logical 0: $\leq 0.3V * VDD$ Logical 1: $\geq 0.8V * VDD$
Maximum cable length	5 m (16.4 ft) w/o signal booster

Effect of VDD in the range 3.3 to 5.0 V (see note below)	
Temperature (digital)	<0.05 °C
Humidity (digital)	<0.25 %RH
Analog signals	<2mV (reference: digital value)

Note: for models HC2-IC, HC2-IM and HC2-IE, VDD is limited to 3.3 V ± 0.1V

General specifications	
Housing material	See Models
Collar material (connector)	Stainless steel, 1.4301
Dust filter material	See Models
Protection grade	IP65
Physical dimensions	See Models
Weight	See Models

E-M-HC2 Probes-V1_30	Rotronic AG Bassersdorf, Switzerland
Document code	Unit
HygroClip 2 (HC2) Humidity Temperature Probes: User Guide	Instruction Manual
	Document Type
Document title	Page 28 of 31

Conformity to standards	
CE / EMC immunity	EMC Directive 2004/108/EG: EN 61000-6-1: 2001, EN 61000-6-2: 2005 EN 61000-6-3: 2005, EN 61000-6-4: 2001 + A11
Solder type	Lead free (RoHS directive)
FDA / GAMP directives	compatible

Environmental limits	
Storage and transit	-50...+100 °C / 0...100 %RH, non condensing
Operating limits at electronics	-50 ... +100 °C 0...100 %RH, non condensing
Temperature limits at sensor	See Models
Maximum humidity at sensor	100 %RH up to 80 °C (176 °F) 75 %RH at 100 °C (212 °F) 45 %RH at 125 °C (260 °F) 15 %RH at 150 °C (302 °F)
Maximum air velocity at probe	20 m/s (3,935 ft /min)
Critical environments	Humidity sensor: as per DV04-14.0803.02 - Critical chemicals

10.2 Dew point accuracy

The HC2 probes can be configured to calculate either the dew point or frost point based on the measurement of relative humidity and temperature. The accuracy of this conversion varies, depending on the humidity and temperature conditions as shown in the graph below:

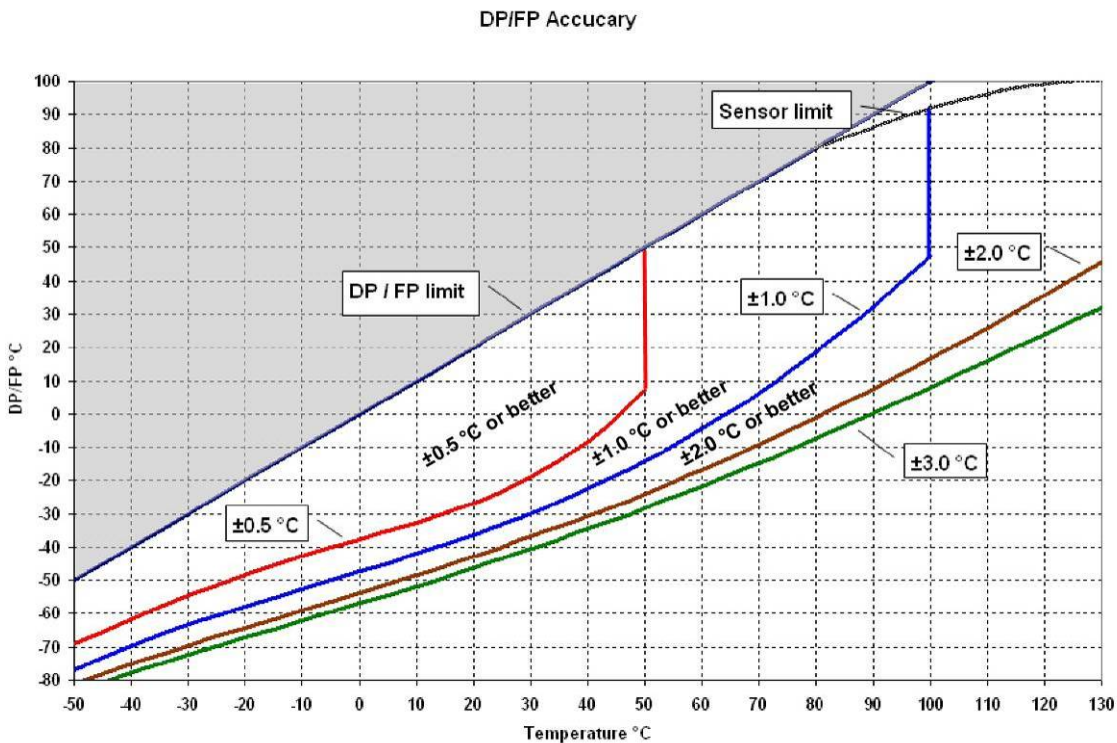

Example: at a temperature of 20 °C, a dew point value of -37 °C is measured with an accuracy of $\pm 1.0\text{ °C}$ or better.

E-M-HC2 Probes-V1_30	Rotronic AG Bassersdorf, Switzerland
Document code	Unit
HygroClip 2 (HC2) Humidity Temperature Probes: User Guide	Instruction Manual
	Document Type
Document title	Page 29 of 31

10.3 *Effect of cable temperature on the accuracy of probes HC2-C04 and HC2-C05*

Accuracy of the HC2-C04 and HC2-C05 probes is affected by the temperature of the cable separating the sensors from the electronics.

Error on humidity:

Humidity measurement accuracy is specified at ± 1.0 %RH when both the humidity sensor and the cable are at 23 °C. Depending both on the value of temperature and on the exposed length of cable, the probe exhibits a predictable error (bias) as illustrated below:

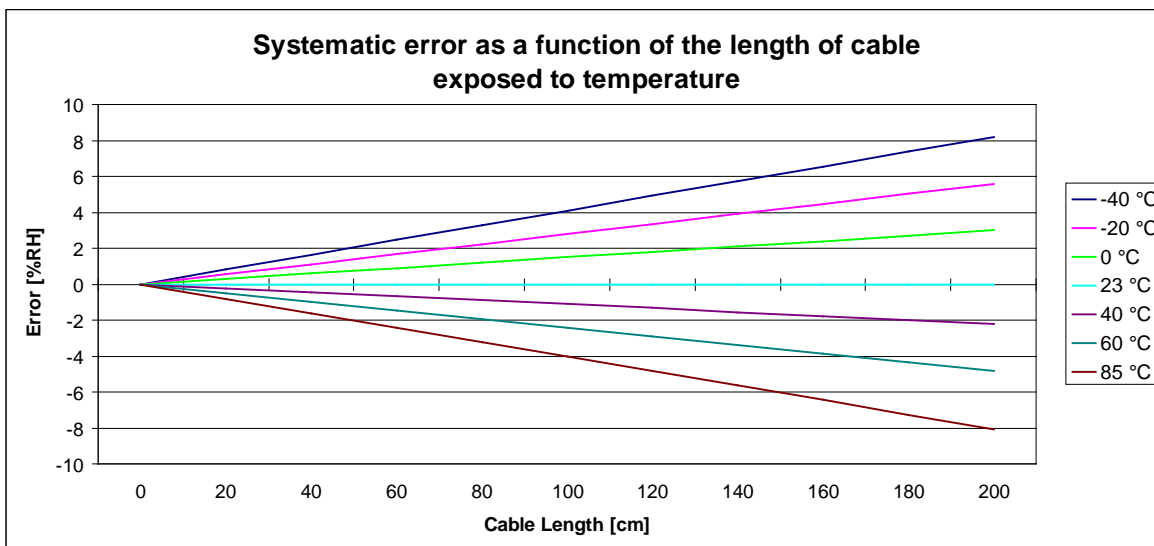

Error on temperature:

Temperature measurement accuracy is specified at ± 0.3 °C when both the temperature sensor and the cable are at 23 °C. When the full length of the 2 meter probe cable is exposed to temperature values within the range of -40 to 85 °C, the additional error is limited to 0.125 °C.

11 Accessories and parts

For accessories and parts such as the HW4 configuration software, extension cables, adapter cables, calibration accessories and spare dust filters, please see document **E-M-HC2-accessories**

E-M-HC2 Probes-V1_30	Rotronic AG Bassersdorf, Switzerland
Document code	Unit
HygroClip 2 (HC2) Humidity Temperature Probes: User Guide	Instruction Manual
	Document Type
Document title	Page 30 of 31

12 Supporting documents

Document File Name	Contents
E-M-HC2-accessories	Accessories and parts for probes, indicators and transmitters
E-T-AC3000-DF-V1	AirChip 3000 Description and Main Functions
E-M-HW4v3-DIR	List of the HW4 manuals
E-M-HW4v3-Main	HW4 software version 3: General instructions and functions common to all devices
E-M-HW4v3-F2-001	HW4 software version 3: HC2 probe series Device configuration and AirChip 3000 functions
E-M-HW4v3-A2-001	HW4 software version 3: Probe Adjustment function AirChip 3000 devices
E-M-HW4v3-DR-001	HW4 software version 3: Data Recording Function AirChip 3000 Devices
E-M-AC3000-CP	AirChip 3000 Communication Protocol
E-M-TCPIP-Conf	Configuration procedures for ROTRONIC devices with Ethernet (TCP/IP) interface
E-M-CalBasics	Temperature and humidity adjustment basics Instructions for using the ROTRONIC humidity standards
E-T-HumiDefs	Humidity Definitions

Note: All document file names have an extension corresponding to the document release number (example of a first release: E-M-HW4v2-Main_10). This extension is not shown in the above table.

E-M-HC2 Probes-V1_30	Rotronic AG Bassersdorf, Switzerland
Document code	Unit
HygroClip 2 (HC2) Humidity Temperature Probes: User Guide	Instruction Manual
Document title	Document Type
	Page 31 of 31

13 Document releases

Doc. Release	Date	Notes
_20	Apr. 11, 2009	Original release
_21	Aug. 19, 2009	Added probe model HC2-AW Corrected the specification of some of the probe materials
_22	Jun. 18, 2010	Updated document to HW4 software v.3
_23	May 20, 2011	Modified dimensional specifications of the HC2-C04 probe
_24	Jan. 6, 2012	Changed the factory default for data recording to "disabled"
_25	May 30, 2013	Page 10: reduced maximum pressure to 100 bar / 1450 PSI for the HC2-IE102/105 and HC2-IE302/305
_26	Nov. 2013	Changes for HygroClip2 with firmware v3.0 Power supply range changed to 3.3...5 VDC HC2-IE maximum pressure range changed to 100 bar. Added HC2-SM Added HC2-IMxxx-M Added HC2-IExxx-M
_27	July 2014	Korrekctions of technical specification
_28	March 2015	Update of Pt100 class. Industrial probes are delivered with Pt100 1/3 class B since the end of March 2015.
_29	March 2015	Accuracy range updated
_30	March 2015	IP protection class added Updated spec of collar material