

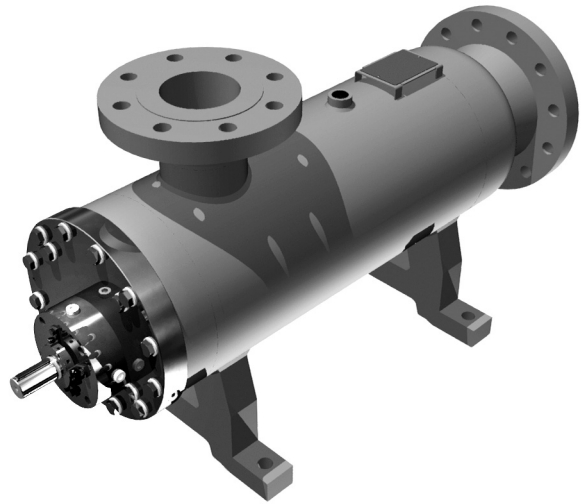

TWIN SCREW PUMP PCX-WTG



- Full Stainless Steel Construction API676

PERFORMANCES

TWIN SCREW PUMP

SERIES

PCX-WTG

ADVANTAGES

- High flow capacity (lubricating and fuels application)
- Full Stainless Steel Construction
- Self priming capacity
- Low noise / vibration
- High viscosity range
- Constant performance
- Wide range of customization

FUNCTIONAL CHARACTERISTICS

- Delivery flow : Up to 9000 l/min (*)
- Admissible differential pressure : Up to 16 Bar (435 psi) (*)
- Admissible suction pressure: from -0.7 to 10 bar (*)
- Admissible kinematics viscosity: from 5 to 25000 cSt (*)
- Admissible speed rotation: from 750 to 3600 (*)
- Admissible temperature : from -50 to 300 C° (*)

(*) for different value contact SEIM

MECHANICAL DESIGN

- Twin screws pump without timing gears
- One single Mechanical Seals, API682 if requested
- Internal Bearings
- Horizontal or Vertical mounting
- External fabricated case
- Internal liner totally removable and replaceable

MATERIALS

- Pump casing and Flanges: Welded Steel (A105 or equivalent); AISI 316L
- Casing insert: A48 Gr.35 or A105N (optional)
- Drive and Idler screws: Hardened Carbon Steel; AISI 410



- PCX-WTG series is the simplest twin screw pump solution
- Compliant to API 676 Last Ed. (on request)
- Available with magnetic coupling



(Without Timing Gears)

PERFORMANCES

TWIN SCREW PUMP

SERIES

PCX-WTG

STANDARD INSPECTION & TEST PLAN

- 100% Visual and Dimensional Inspection of critical raw materials
- Automatic dimensional control of all screw sets
- 100% VDMA Performance and Seal Leakage Test
- 100% Hydrostatic Test or Air Leakage Control Test
- 100% API676 Performance Test of API compliant units
- 100% API676 Hydrostatic Test of API compliant units
- 100% Visual & Dimensional Check before shipment
- 100% Main components 3.1 material certificate

OPTIONAL TEST

- Mechanical Running Test compliant to API676 or purchaser specification
- Vibration Test compliant to VDMA 24284 or purchaser specification
- Complete Unit Test

- Sound Pressure Test
- Cleanliness inspection report before kitting
- Third part inspection report
- For other tests please contact Seim housing, check/foot valves, sensors, starting valves

ACCESSORIES

Common Baseplate, coupling, coupling guards, strainers, bell housing, check/foot valves, sensors, starting valves

DRIVERS

Electric Motors; Diesel engines; Steam turbines

SECTION AND COMPONENTS

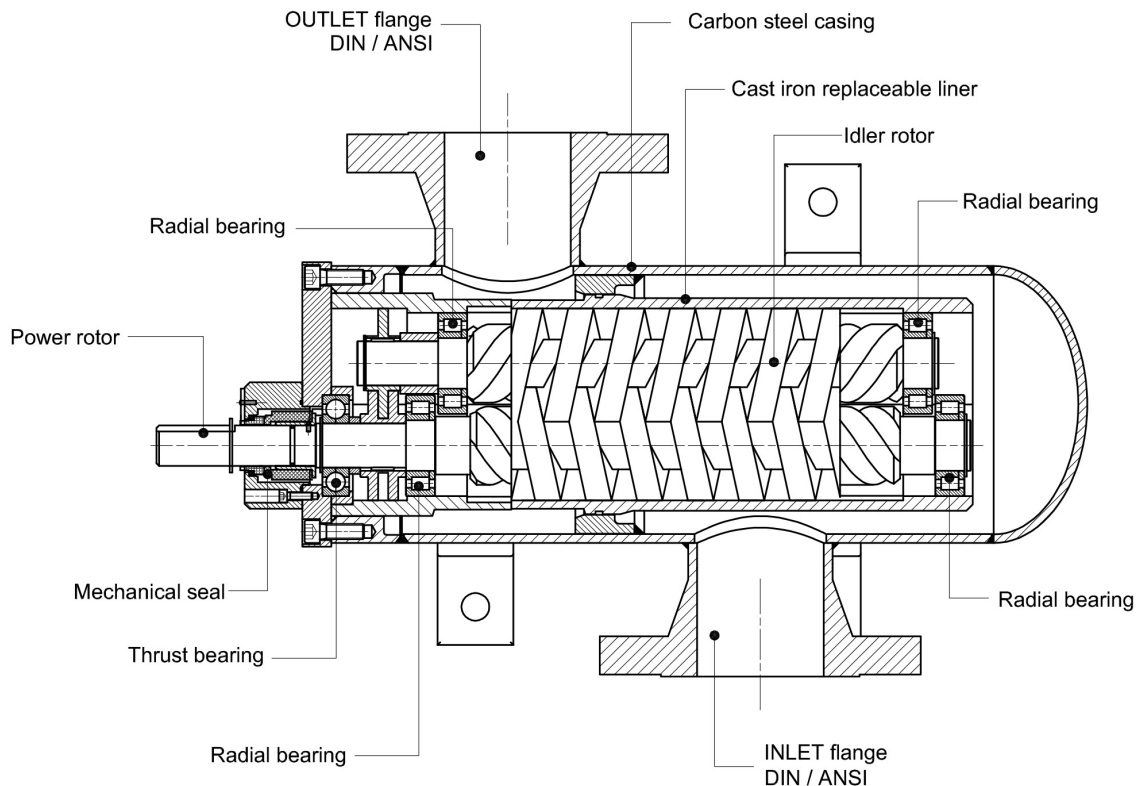

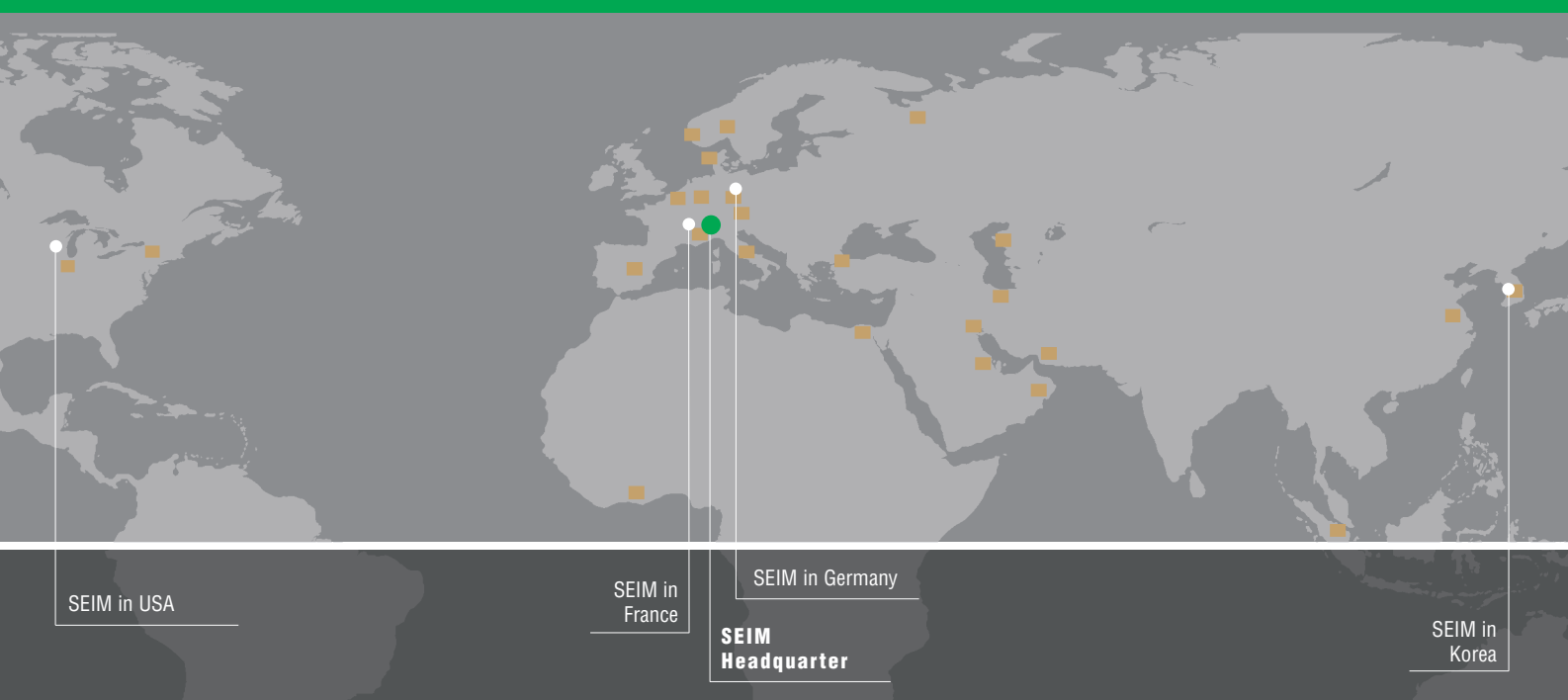

■ SEIM Agent, Distributor, Service Point



SEIM Germany: Sales, After Sales, Warehouse



SEIM France: Sales, After Sales, Warehouse, local Test Bench



SEIM Korea: Sales, After Sales, Warehouse, local Test Bench



SEIM America: Sales, After Sales, Warehouse, local Test Bench



SEIM HEADQUARTER

SEIM S.r.l.

Via Volta, 17- 20090 Cusago

Milano - Italy

Tel. +39 02 903 92 11

Fax +39 02 903 921 41

www.seim.it - e-mail: seim@seim.it

