

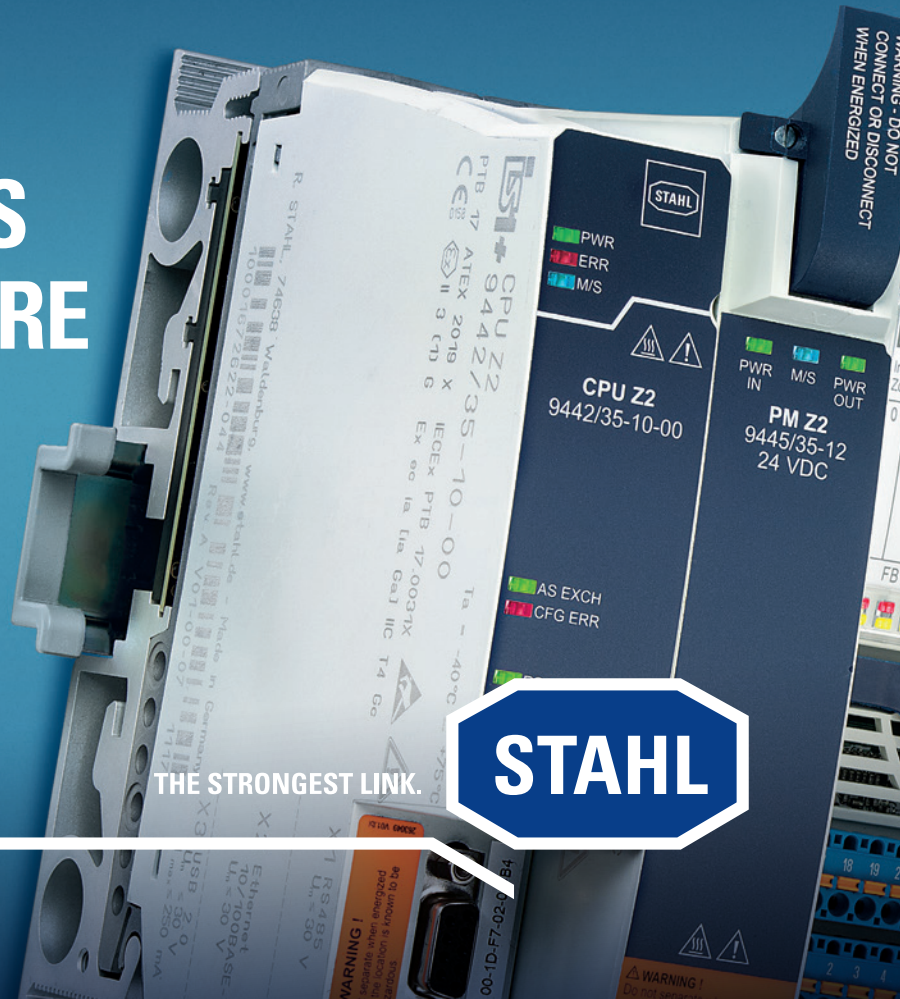

INNOVATIONS FOR THE FUTURE



THE STRONGEST LINK.

STAHL

DIGITAL REVOLUTION MEETS EXPLOSION PROTECTION

How is the progressive digitalisation in companies changing the requirements for explosion protection? This is the challenge that R. STAHL has been facing for many years, and is continuously bringing **innovative products** and **new solutions** to the market: from the most modern LED luminaires, signalling devices and installation devices to switchgears and control systems. There are also the latest automation and network solutions, HMI and camera technologies or modular units for easy integration into systems – we can offer you every kind of **future-proof explosion**

protection and safety technology. At R. STAHL, we master all types of protection, have a wide range of products at our disposal, and have a high level of vertical integration. Furthermore, the link to the Industrial Internet of Things, the productive use of big data to optimise processes, and cybersecurity all play a decisive role in our **EX 4.0 solutions**. We are therefore well placed to optimally satisfy your requirements. In addition to advanced products, **explosion-protected system solutions** are the focus of our range of services – perfectly tailored to your individual

operating conditions. We support you along the whole process – from the time we receive your request to developing an optimum solution, commissioning and after-sales service. We offer you a relationship as a trusted **partner** that is dependable **no matter where you are.**

01	Introduction to R. STAHL Introduction to R. STAHL	4
02	Hazardous Location Overview Hazardous Location Overview	16
03	Intrinsic Safety Overview Intrinsic Safety Overview	36
04	Application Guide Application Guide	46
05	Automation Portfolio Automation Portfolio	48
06 a	Remote I/O – Chapter Index Tables Remote I/O – Chapter Index Tables	50
06 b	Remote I/O General CPU & Power Modules Analog Modules Digital Input Output Modules Digital Output Modules Temperature Input Modules System Components and Accessories Enclosures for Fieldstations	56
07 a	Isolator Barriers – Chapter Index Tables Isolator Barriers – Chapter Index Tables	138
07 b	Isolator Barriers General Ex i-Isolators – Digital Input Ex i-Isolators – Analog Input Ex i-Isolators – Analog Output Ex i-Isolators – Digital Output Ex i-Isolators – Temperature Input System Components	148
08 a	Zener Barriers Applications Application Information	218
08 b	Zener Barriers Applications Single-Channel Zener Barriers Dual-Channel Zener Barriers	230
09	Foundation Fieldbus Components General Fieldbus Power Supply Diagnosis Communication Module bus-Carrier Field Device Coupler Fieldbus Terminator	266

10 a	HMI Systems – Chapter Index Tables HMI Systems – Chapter Index Tables	290
10 b	HMI Systems HMI Technologies for All Applications HMI Device Platforms	294
11	Network and Wireless Solutions General HFisolator Wi-Fi Access Point Media Converter Isolating Repeater for Profibus / Modbus RTU	324
12	Additional Technology and Signaling Terminal Boxes Audible and Visual Signaling Devices Audible Signaling Devices Visual Signaling Devices	344
13 a	Camera Systems – Chapter Index Tables Camera Systems – Chapter Index Tables	372
13 b	Camera Systems Video Software Camera and Video Systems Color Camera Thermal Imaging Camera	374

INTRODUCTION TO R. STAHL



Product	Series	Page	WebCode
Introduction to R. STAHL			
After Sales Service, Logistics		11	
Development, Laboratory / Certification		8	
Expertise		5	
Expert Training		13	
Our Mission		6	
Production		7	
Project Planning, Production		9	
Quality Management, On Site Acceptance Testing		10	
Service		12	
System Solutions Capabilities		14	

For additional products and information please refer to r-stahl.com

EXPERTISE

WHERE SAFETY KNOWS NO COMPROMISE

01

R. STAHL IN AMERICA

R. STAHL, INC. has been in North America for almost 40 years. Located in Houston, TX and Edmonton, AB, Canada, we have expanded to include over 40 representatives throughout the Americas. Our service is unmatched, with qualified technical experts that can be reached in real time, not seven hours away in Europe.

One hundred forty-four years after our founding, with facilities strategically located on five continents, R. STAHL is acknowledged as the world's foremost innovator in explosion-protected components and systems for Automation, Control & Distribution, Operations & Monitoring, and Lighting, as well as Signals.

Our commitment to the Americas began in 1979 when R. STAHL introduced intrinsic safety technology to the North American market. It rose to greater prominence in the mid-1990s, when R. STAHL played a leading advocacy role in the harmonization of the U.S. National Electrical Code (NEC) and the International Electrical Code (IEC). Changes made at that time yielded increased global standardization, and gave rise to heightened efficiency and maintenance benefits for international markets.

Our expertise also covers related areas of safety engineering such as functional safety, SIL and FDA. International certifications, approvals and patents underline our expertise and make it possible for R. STAHL products to be used anywhere in the world. One thing is certain: on the basis of experience and international synergies, we continue to deliver technological innovations tailored to your individual needs.

BENEFITS

- All protection methods available
- Over 3,000 certificates for explosion protection issued
- More than 70 active patents
- Technical training
- Member of many international committees, technical commissions and research groups (Profibus, FieldbusFoundation HART etc.)
- In-house testing laboratory



OUR MISSION

We provide products and services to protect the most valuable — and often irreplaceable — assets of some of the most critical industries on Earth.

The production, processing, transportation and storage of many materials may often lead to grave danger. Flammable gases, vapors, mists and dusts can occur that, when combined with oxygen in the air, form an explosive atmosphere. Given a source of ignition, these substances can detonate and destroy life and property in seconds.

While global in applications and understanding, R. STAHL also has solutions designed and developed to address unique North American requirements as well, making R. STAHL “The Strongest Link.”

PROMISES TO OUR CUSTOMERS

We will provide you with the best engineering minds available to protect your people and property from explosions.

We offer you only products we know to embody the finest technology and craftsmanship. We carefully develop and engineer the right solutions for your individual applications.

We deliver your products and services quickly and efficiently.

We serve you in a manner that places R. STAHL above our competitors in giving you peace of mind about the safety of your people and property.

AREAS OF APPLICATION

- Oil & Gas exploration, transportation, and refining
- Petrochemical industry
- Chemical industry
- Pharmaceutical industry
- Food product, beverage and tobacco industries
- Shipbuilding and offshore industries
- Food processing industry
- Water purification
- Automotive industry
- Original equipment manufacturers
- Grain storage, processing & transportation industry
- Coal processing industry
- Power generation industry



PRODUCTION

R. STAHL's global headquarters is located in Waldenburg, Germany, and its American headquarters is located in Houston, Texas, USA. R. STAHL, INC. is proud of its world class manufacturing, engineering and technical service competency. Here, our engineers work together in teams to develop tailor-made, reliable and cost-effective solutions for complex systems worldwide.

Project management and production departments work side by side to foster communication and cooperation between all departments throughout the entire production process. Flat hierarchies, flexibility and open dialog describe our culture. Our large portfolio of components and systems forms the basis for our explosion protection system solutions, all of which are designed to work seamlessly with each other.

This guarantees our customers the reliability they require and the assurance that a project will be successful. Our expert representatives will update you on your project status at any time. Our other manufacturing facilities located in Weimar (Germany) and Cologne (Germany), Stavanger (Norway), Hengelo (Netherlands) and Chennai (India) adhere to the same high standards.

PRODUCTION PLANTS

- Houston
- Waldenburg
- Weimar
- Cologne
- Hengelo
- Stavanger
- Chennai



DEVELOPMENT

- Leadership in global industry codes, standards and certification schemes
- Interconnected Development Offices allow for products to be developed with complete alignment for the target geographic market
- We use state-of-the-art software, 3D printing and rapid prototyping for design and preliminary testing



LABORATORY / CERTIFICATION

- All key tests are performed on site in our own state-of-the-art testing facilities
- We hold over 3,000 international certificates for explosion protection, shipping vessel approvals and functional safety
- We offer factory-accepted testing for domestic and international projects

PROJECT PLANNING

- Extensive cooperation with customers to develop their optimal solution
- Highly skilled engineers with international experience design solutions based on your individual needs

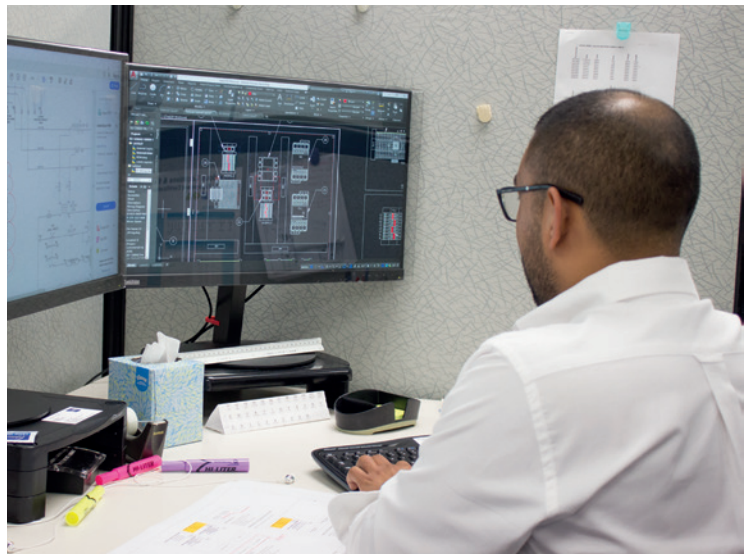

01



PRODUCTION

- Manufacturing plants located in: Houston, Texas (USA), Waldenburg, Weimar & Cologne (Germany), Hengelo (Netherlands), Stavanger (Norway) and Chennai (India)
- Deployment of LEAN Manufacturing Concepts result in flexible production, and organized manufacturing provides effective communication between all departments
- In-house occupational training center with educated trainers
- In-house tool-and-die manufacturing facilities

QUALITY MANAGEMENT

- ISO 9001 certified since 2015
- Quality management system is approved by DEKRA
- ATEX & IECex Quality Management System Certified by DEKRA to ISO IEC 80079-34
- Quality management process covers the whole supply chain
- Calibration laboratory monitors over 2,000 items of electrical and mechanical test equipment
- Production process is covered by quality assurance



ON-SITE ACCEPTANCE TESTING

- On-site testing and inspection equipment
- Intensive technical support
- Personnel are continuously trained on the latest technology
- On-site consultants are in direct contact with development product managers



AFTER SALES SERVICE

- Extended warranty on products and services
- Field service engineers available
- Competent information given by telephone and email



LOGISTICS

- Efficient and economical workflow
- Modern, fully automatic high-bay warehouse
- Production organized on the lean principle

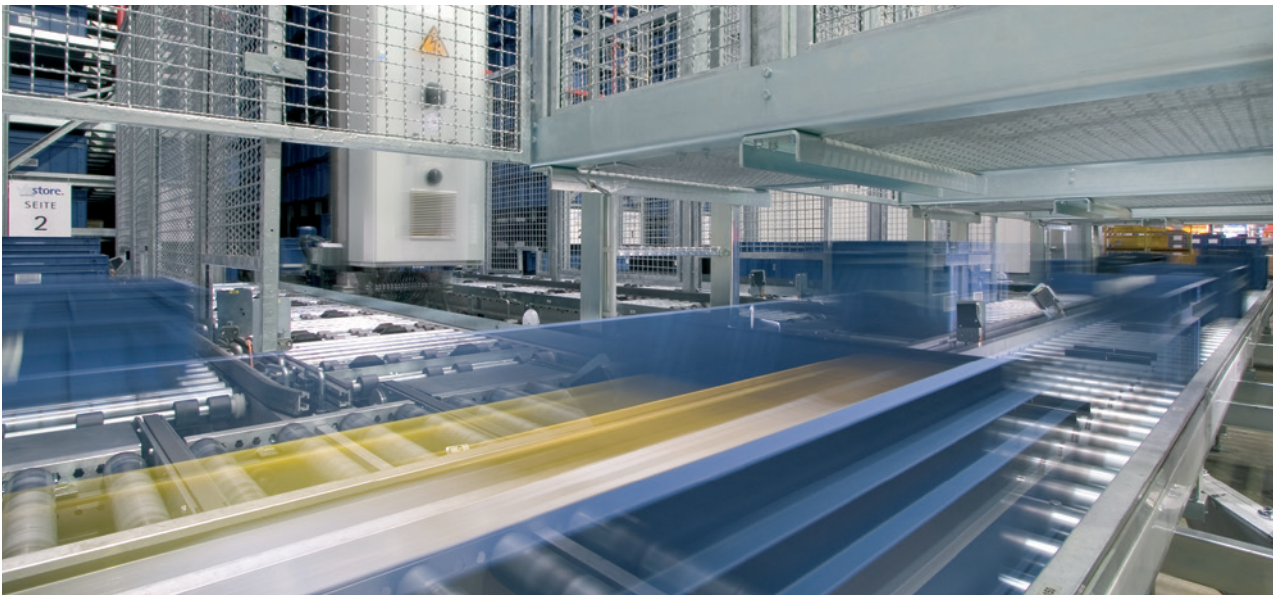

SERVICE

Protecting lives and equipment is R. STAHL's highest priority. When you partner with R. STAHL in this endeavor, you can be assured that our customized, technically advanced, comprehensive products and services are all of the highest quality.

OEM SERVICE

On a worldwide basis, Original Equipment Manufacturers are continuously looking to expand their markets with existing and new system designs. When market opportunities arise that require IECEx or ATEX certification for markets, such as Europe, the Middle East, Asia and Russia, R. STAHL is the preferred partner.

In North America, producing custom, quality products - often with extremely tight turnaround times - is an R. STAHL specialty.

With our more than seventy-five years of experience, we stand ready to guide and educate OEMs and their engineering teams in meeting global electrical codes and standards in all harsh environments and hazardous (classified) locations.

AFTER SALES SERVICE

- Development of individual solutions
- Technical service
- After-sales service
- Expert information available via hotlines
- Global distribution network
- Relevant information via r-stahl.com
- Permanent order status updates
- Flexibility
- Quality management
- Fast, reliable shipping
- 24-hour turnaround on pick-and-pull items
- International customer support
- International shipping
- Training



EXPERT TRAINING

Competent and trained employees are the most important link in a safe production chain. Remaining at the top of an industry requires committed employees who work diligently with new technologies and implement new safety regulations.

At R. STAHL, we are aware of this and make our expert knowledge available to you by conducting training classes. Individuals may choose to take advantage of a basic or advanced training class. Our specialists convey theory and practice in equal measure. Individuals may choose to hold training classes at their own location or at our facility.

R. STAHL training classes provide participants with valuable knowledge pertaining to engineering, scientific principals and implementation of the NEC, CEC and ATEX / IECEx requirements.

- Training programs
- In-house training center
- Training classes conducted at the customer's facility

SYSTEM SOLUTIONS CAPABILITIES

R. STAHL, INC. offers its hazardous location expertise from concept to delivery of certified solutions. Our proposals department will work with the customer to design a solution that is easy to install, easy to maintain and cost effective for the specific customer application.



EXPERTS

R. STAHL, as a hazardous location expert, will recommend the best approach for the customer. In many cases, the solution will be a mixture of protection methods. The protection methods used in our shop are: non-incendive, intrinsic safety, purge and pressurization, explosion-proof, dust ignition-proof, dust-tight and increased safety.

Our shop is able to build and certify the following standards:

- NEC and CEC - ETL - NRTL Lab (Class I Division 2, Class I Division 1, Class II Division 2, Class II Division 1, Zone 2, Zone 1, Zone 22, Zone 2)
- IECEx, ATEX - DEKRA (Zone 2, Zone 1, Zone 22, Zone 21) and others, such as INMETRO, PESO & EAC.

SYSTEM SOLUTION

Our system solution process consists of:

CONCEPT

Customer defines hazardous areas of installation and certifications needed. Customer will provide internal components and interconnection information.

QUOTATION

R. STAHL team will recommend a protection method to use and provide quote with concept drawing and tentative bill of materials.

PURCHASE ORDER

Once the order has been received, production drawings will be prepared.

APPROVAL

Customer will approve production drawings with final BOM and certification details.

PRODUCTION

Production team will procure all needed components (R. STAHL as well as 3rd party items) and build the system at its Stafford, TX location.

CERTIFICATION

QA and certification team will perform a detailed inspection and stamp the solution accordingly to approve drawings.

PACKING AND SHIPMENT

Solution will be properly packed for transportation using customer's preferred transportation method.



REMOTE I/O SYSTEM

DNV panel for Class 1, Division 2 NEC, CEC installation.
Including 320 Remote I/O points

01



HMI PANEL SYSTEM

HMI system for Zone 1 ATEX, CEC installation with access
point included



PANEL SYSTEM SOLUTIONS

Purge panel with PLC and HMI for Zone 1 ATEX, CEC and/or
Class I, Division 2

HAZARDOUS LOCATION OVERVIEW



Product	Series	Page	WebCode
Hazardous Location Overview			
ATEX Directive, Equipment Group I and II Overview		34	
ATEX Marking, IECEx Scheme		35	
Basics of Explosion Protection		17	
Class II and III Locations		19	
Combustible Dust Protection Methods		23	
Comparison of Specific Applications of Enclosure for Indoor or Outdoor Unclassified Location		26	
Environmental Protection NEMA and CSA Type Enclosure		25	
Equipment Certification Typical Canadian Marking to SEC 18 (Gas) and Annex J (Gas and Dust)		30	
Equipment Certification Typical European Marking (Gas and Dust)		32	
Equipment Certification Typical IEC Marking (Gas and Dust)		31	
Equipment Certification Typical U.S. Marking to NEC® 500 (Gas and Dust)		28	
Equipment Certification Typical U.S. Marking to NEC® 505 and NEC® 506		29	
Equipment Protection Level (EPL)		33	
Hazardous Location Basics, Class I Locations		18	
Ingress Protection (IP)		27	
Methods of Protection (Gas)		21	
Permitted Techniques (Gas and Dust)		24	
Temperature Classes, Ambient Temperature		20	

For additional products and information please refer to r-stahl.com

HAZARDOUS LOCATION OVERVIEW

BASICS OF EXPLOSION PROTECTION

02

HAZARDOUS LOCATIONS

Hazardous locations are defined as premises, buildings or parts thereof where fire or explosion hazards may exist due to the presence of flammable gases or vapors, flammable liquids, combustible dusts or easily ignitable fibers or flyings.

Although, flammable gases, vapors and combustible dusts exist almost everywhere; fortunately, they are present only in minute quantities. A location is not defined as hazardous simply due to the presence of flammable gases or vapors, or combustible dusts. The quantities or concentrations must be sufficient to present a potential explosion hazard.

The electrical codes that deal with these types of hazardous location areas do not cover certain materials such as high explosives like dynamite, munitions and fireworks. Other rules and regulations handle areas involving these materials.

UNDERSTANDING GLOBAL HAZARDOUS LOCATION REQUIREMENTS

The evolution of hazardous location electrical codes and standards throughout the world has taken two distinct paths.

In North America, a Class, Division system has been used for decades as the basis for area classification of hazardous (classified) locations. Because the hazards and methods of protecting electrical equipment from these hazards vary for different materials, hazardous locations are divided into three Classes and two Divisions. The Classes are based on the type of hazard and the explosive characteristics of the material, and the Divisions are based on the occurrence or risk of fire or explosion that the material presents. While the United States and Canada have some differences in acceptable wiring methods and product standards, their Class, Division systems are very similar.

In other parts of the world, areas containing explosive atmospheres are defined using the Zone system.

Zones are based predominantly on the International Electrotechnical Commission (IEC) and European Committee for Electrotechnical Standardization (CENELEC) standards. In order to provide multiple options of classification in hazardous locations, North America has additionally introduced a Zone system. In Canada, the Zone system for area classification has become the preferred (required) method, though the Class, Division system is still prominent in current facilities.

HAZARDOUS LOCATION BASICS

02

In North America, hazardous locations are separated into three Classes based on the explosive characteristics of the materials. The Class or type of material is further separated into Divisions or Zones based on the release of the flammable material. The Zone system has three levels of hazard in contrast to the Division system's two levels.

Selection Table			
Hazardous Materials	Schemes / Classifications		
	Class, Division System	Class, Zone System	Zone System
	NEC® 500 / CEC Appendix J	NEC® 505, 506	CEC Section 18 IECEx / ATEX
Gases or Vapors	Class I, Division 1	Class I, Zone 0, Zone 1	Zone 0
	Class I, Division 2	Class I, Zone 2	Zone 1, Zone 2
Combustible Dusts	Class II, Division 1	Zone 20, Zone 21	Zone 20
	Class II, Division 2	Zone 22	Zone 21, Zone 22
Fibers or Flyings	Class III, Division 1	Zone 21	Zone 20
	Class III, Division 2	Zone 22	Zone 21, Zone 22

CLASS I LOCATIONS

Class I locations are those in which flammable “gases or vapors” are, or may be, present in the air in quantities sufficient to produce explosive or ignitable mixtures. The terms, “gases or vapors,” differentiate between materials that are in a gaseous state under normal atmospheric conditions, such as hydrogen or methane, and a vapor such as gasoline that is flashed off from a liquid under normal atmospheric conditions.

The subdivisions of Class I into Divisions (this concept applies to Class II and Class III as well) or Zones is based on the probability that an explosive gas atmosphere may be present in a location. If the risk is extremely low, the location is considered unclassified. A good example of a low risk area is a single family home with a natural gas or propane furnace for heating.

The gas could, and on extremely rare occasions does, leak into the home, encounter an ignition source and an explosion occurs, usually with devastating results. However, since the risk is so low, because of the safety systems built into the gas supply and heating equipment, these areas are not “hazardous (classified) locations”.

The NEC® (National Electrical Code) and CEC (Canadian Electrical Code) have incorporated the international definitions for Zones for Class I, locations. The two codes continue to address the Division system although the methods are somewhat different.

The frequency of occurrence determines the level of hazard for a location. Simply stated, the longer the hazardous material is present, the greater the risk.

Frequency of Occurrence	Class, Division System	Class, Zone System
Continuous	Class I, Division 1	Class I, Zone 0
Intermittent Periodically		Class I, Zone 1
Abnormal Condition	Class I, Division 2	Class I, Zone 2
Not Expected	Unclassified	Unclassified

The graphs below compare the Division and Zone systems in terms of risk assessment.

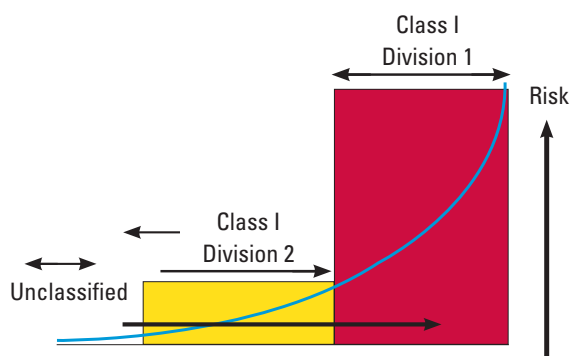

The abnormal conditions of occurrence, or lower risk areas, in the Zone and Division system are basically identical. However, in areas where a hazard is expected to occur in normal operation, the Zone system deals with the highest risk areas separately, and risk associated with the remaining location is considered lower. The Division system tends to be less specific in its consideration of Division 1. The Division system treats all areas where a hazard is expected to occur in normal operation the same.

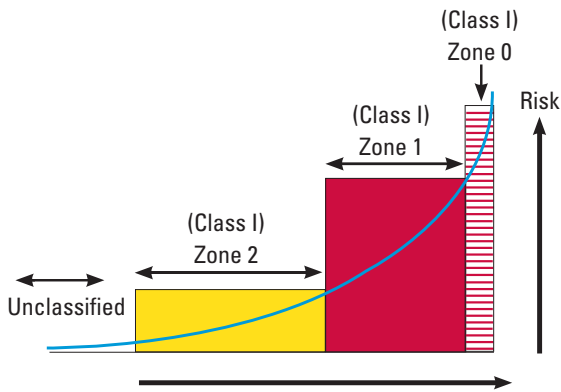

Class I locations are further divided into Groups based on the explosive properties of the materials present. Under the Class & Division system, North America uses four Gas Groups, while the IEC/CENELEC and the U.S. and Canada Zone system use three. A product can be evaluated for a single gas or vapor, or for a single gas from a Gas Group. A common application of a single gas listing is Group "IIB + hydrogen" to address certain construction limitations and possible multiple listings. The chart below compares the two systems.

Typical Gas	Class, Division Gas Groups	Zone Gas Groups
Acetylene	A	II C
Hydrogen	B	
Ethylene	C	II B
Propane	D	II A

CLASS II LOCATIONS

Class II locations are those that are hazardous due to the presence of combustible or electrically conductive dusts. The dust must be present in sufficient quantities for a fire or explosion hazard to exist. The fact that there is some combustible dust present does not mean a Class II hazardous location exists.

Class II substances are divided into three groups for similar reasons as Class I materials. Class II groups are based on different characteristics than those of Class I, given the requirements for an explosion to occur and the protection methods required for equipment. In Class II locations, the ignition temperature, the electrical conductivity, and the thermal blanketing effect of the dust are critical when dealing with heat-producing equipment, such as lighting fixtures and motors. It is these factors that are the deciding factors in determining the Class II groups.

Groups	Type of Material	Examples
E	Metal Dusts	Powder Metals such as Aluminum or Magnesium
F	Carbonaceous Dusts	Carbon Black, Coal Dust or Coke Dust
G	Agricultural Dusts	Grain, Flour, Sugars, Spices and certain Polymers

The IEC has developed Zones for atmospheres containing combustible dusts, which again separates areas into three Zones 20, 21 and 22.

Zone 20, 21, and 22 Locations

The IEC/CENELEC, the U.S. and Canada have introduced the three-Zone system for combustible dust locations.

The definitions are as follows:

Zone 20 – an area in which a combustible dust, as a cloud, is continuously or frequently present during normal operations in sufficient quantities to produce an explosive mixture.

Zone 21 – an area in which a combustible dust, as a cloud, is likely to occur during normal operations in sufficient quantities to produce an explosive mixture.

Zone 22 – an area in which combustible dust clouds may occur infrequently and persist for only short periods of time or in which accumulations or layers may be present under abnormal conditions.

CLASS III LOCATIONS

Class III locations are those which are hazardous due to the presence of easily ignitable fibers or flyings. However, the material is not suspended in the air in quantities which are sufficient enough to produce ignitable mixtures.

Easily ignitable fibers and flyings present a serious fire risk, not normally an explosion hazard. The greater danger with Class III materials is that if a layer forms throughout a facility, an ignition will cause a flash fire which moves at near explosive speeds.

In the Zone system, fibers and flyings are treated under Zone 20, 21 and 22.

TEMPERATURE CLASSES

Ignition temperature or auto-ignition temperature (AIT) is the minimum temperature of a surface at which an explosive atmosphere ignites. Flammable vapors and gases can be classified into temperature classes according to their ignition temperature. The maximum temperature of a piece of equipment must always be lower than the ignition temperature of the gas-air mixture or vapor-air mixture in which it is placed. Equipment shall be marked to show the operating temperature or temperature class. The temperature class (T code) is indicated on the manufacturer's nameplate and is based on the table below.

Temperature Class			
In America Temperature Code	IEC / CENELEC / NEC@ 505 Temperature Class	Maximum Temperature	
		°C	°F
T1	T1	450°C	842°F
T2	T2	300°C	572°F
T2A	-	280°C	536°F
T2B	-	260°C	500°F
T2C	-	230°C	446°F
T2D	-	215°C	419°F
T3	T3	200°C	392°F
T3A	-	180°C	356°F
T3B	-	165°C	329°F
T3C	-	160°C	320°F
T4	T4	135°C	275°F
T4A	-	120°C	248°F
T5	T5	100°C	212°F
T6	T6	85°C	185°F

* In Class, Division system, T code T5 and T6 are not required to be marked.

AMBIENT TEMPERATURE

The ambient temperature is the surrounding temperature of the environment in which a piece of equipment is installed, whether it is indoors or outdoors. The standard temperature range for equipment designed and evaluated for installation in the Zone system is -20°C to +40°C, and in the Division system -25°C to +40°C. For these ranges, no ambient temperature marking is required on the product. In the case of electrical equipment that is designed for use in a range of ambient temperature other than those stated, the actual ambient temperature range shall be marked on the equipment nameplate.

In most cases, the R. STAHL product lines exceed the temperature requirements mentioned above. Refer to the appropriate catalog pages for the product-specific "Ambient

Temperature Range". Any ranges outside the ranges stated above are marked on the product nameplate.

Applications requiring product with extreme ambient temperature ranges outside those standard ranges stated under the heading "Ambient Temperature Range" are specified under the heading "Special Ambient Temperature Range". Only products with this additional catalog information can be customized for extreme temperature applications. Please consult the factory for your special needs.

EXPLOSIVE GAS PROTECTION METHODS

There are a number of methods of protecting electrical equipment to prevent an explosion when the equipment is used in a flammable gas atmosphere.

Three elements are required for an explosion to occur - fuel, oxygen and a heat or ignition source. The fuel and oxygen must be in the correct mixture. Too little fuel, a lean mixture, or too much fuel, a rich mixture, cannot ignite. These explosive limits are defined as the "Upper Flammable Limit" (UFL) and the "Lower Flammable Limit" (LFL).

Either by containing an internal explosion or eliminating one or more of the components necessary for an explosion to occur, each method of protection addresses the "Fire Triangle" in some manner.

The most common North American methods of protection are explosionproof equipment for Class I locations, and dust-ignitionproof equipment for Class II locations. R. STAHL produces a wide range of equipment for use in hazardous (classified) locations.

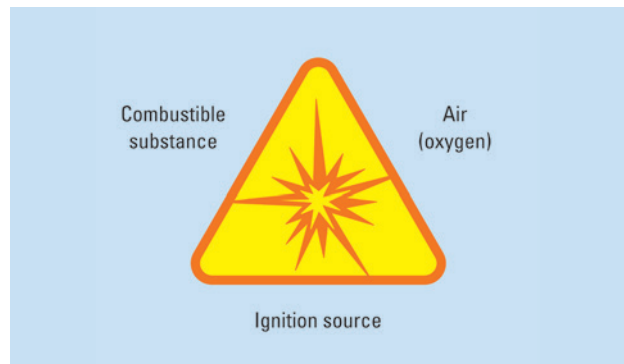

METHODS OF PROTECTION (GAS)



EXPLOSIONPROOF EQUIPMENT OR FLAMEPROOF TYPE OF PROTECTION "d" (da, db, dc)

Although the North American "explosionproof" and IEC "flameproof" concepts are SIMILAR, the requirements in the product standards are different. Explosionproof is a Class 1, Division 1 technology that can be used in a NEC® or CEC defined Class 1, Division 1 and Zone 1 classified area. Flameproof is a Zone 1 technology and **cannot** be used in a Division 1 classified area.

Since flammable gases and vapors are expected inside an enclosure, the equipment must be capable of withstanding an explosion caused by the sparking contacts of devices, high temperatures, or an electrical fault. The enclosure is designed so that hot gases generated during an internal explosion are cooled below the ignition temperature of the surrounding flammable atmosphere as they escape through the joints of the unit.

In addition, the external surfaces of the enclosure must not become hot enough to ignite the surrounding atmosphere due to heat energy within the unit. This heat energy may be the result of normal operation of heat-producing equipment, or the result of an electrical arc to the enclosure from an arcing ground fault. Safety factors are applied to all testing of this type of enclosure to ensure the unit will not rupture as a result of an internal explosion.



ENCAPSULATION – TYPE OF PROTECTION "ma" and/or "mb"

Encapsulation is a type of protection in which the parts that can ignite an explosive atmosphere are enclosed in a resin. The resin must be sufficiently resistant to environmental influences so that the explosive atmosphere cannot be ignited by either sparking or heating, which may occur within the device. This is typically used with electronic devices.



INCREASED SAFETY – TYPE OF PROTECTION "e", "eb" and/or "ec"

Type of protection applied to electrical equipment that does not produce arcs or sparks in normal service and under specified abnormal conditions, in which additional measures are applied so as to provide increased safety against the possibility of excessively high temperatures of arcs and sparks.

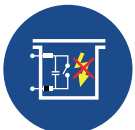

INTRINSIC SAFETY – TYPES OF PROTECTION "i", "ia", "ib" and/or "ic"

This is a type of protection method based upon limiting both electrical and thermal energy under normal and abnormal conditions to levels which are incapable of igniting a hazardous mixture. This protection method is based on creating a protected loop that requires a rated field device as well as the use of intrinsically safe barriers.



LIQUID IMMERSION – TYPE OF PROTECTION "o", "ob" and/or "oc"

Type of protection involving electrical equipment being immersed in a protective liquid in such a way that an explosive atmosphere that may be above the liquid or outside the enclosure cannot be ignited.



PURGE AND PRESSURIZATION – TYPES OF PROTECTION “pxb”, “pyb” and/or “pzc”

This type of protection prevents the surrounding atmosphere from entering an enclosure by maintaining a positive pressure within the unit. Clean air or inert gas is used to maintain a higher pressure than the surrounding atmosphere. In pressurization, the electrical equipment is interlocked with a system which cycles clean air within the unit to remove explosive gases before start-up. Purge systems create an environment classified as less hazardous within the pressurized enclosure.

Type	Explanation for Class, Division	Zone 1
X	Changes the Area within the Enclosure from Class I, Division 1 to unclassified	Zone 1 to unclassified
Y	Changes the Area within the Enclosure from Class I, Division 1 to Class I, Division 2	Zone 1 to Zone 2
Z	Changes the Area within the Enclosure from Class I, Division 2 to unclassified	Zone 2 to unclassified



POWDER FILLING – TYPE OF PROTECTION “q”, “qb” and/or “qc”

Type of protection where electrical parts capable of igniting an explosive atmosphere are fixed in position and completely surrounded by filling material (glass or quartz powder) to prevent the ignition of an external explosive atmosphere.



NONSPARKING EQUIPMENT - TYPE OF PROTECTION “nA” and/or “nAc”*

Type of protection where the device is constructed to minimize the risk of occurrence of arcs or sparks capable of creating an ignition hazard during normal operation.

SPARKING EQUIPMENT - TYPE OF PROTECTION “nC” and/or “nCc”

Equipment which is either sealed so that arcing components cannot be accessed during normal service, or having arcing components such that the arc is not capable of ignition (nonincendive) or the ignition of the atmosphere does not damage the enclosure and transmit to the outside atmosphere (enclosed-break).

HERMETICALLY SEALED

A common type of hermetically sealed equipment is a contact block or reed switch. With this method, the arcing components of the switch are encased in a glass tube. The connecting wires are fused to the glass, sealing the unit to prevent any ingress of flammable gases.

NONINCENDIVE

Protection concept where components have contacts for making or breaking a specified ignition capable circuit; however, the contacting mechanism is designed and constructed so that the component is not capable of causing ignition of the specified explosive gas atmosphere.

RESTRICTED BREATHING ENCLOSURE - TYPE OF PROTECTION “nR” or “nRc”

Type of protection where an enclosure is designed to restrict the entry of gases, vapors and mists.

* This type of protection is no longer used for new equipment (see “ec”).

COMBUSTIBLE DUST PROTECTION METHODS

CLASS II & CLASS III EQUIPMENT

02

Dusttight equipment is designed to exclude dust from entering the enclosure, and to prevent hot particles, arcs, sparks or heat generated inside the enclosure from igniting an exterior accumulation or atmospheric suspension of dusts on or in the vicinity of the enclosure. Nonmetallic enclosures must also prevent the accumulation of static charges on the enclosure itself.

The primary function of the joints of these enclosures is to seal dust out and keep the hot particles etc. inside, therefore, typically the joints are gasketed.

Since this protection method keeps combustible dusts out, the enclosure is not expected or designed to contain an internal explosion. However, the design must be sufficient enough to withstand mechanical abuse.

The ignition temperature of dusts is usually lower than that of gases and vapors, and therefore the control of external surface temperatures is more rigorous for Class II equipment than for Class I equipment. Dust layers on the equipment can act as insulation for the heat generated inside the equipment, which in turn can increase the surface temperature of the unit even under normal operating conditions.

The NEC® defines “Dust-ignitionproof” as the protection for Class II, Division 1 and 2 locations for which it is approved, and “Dusttight” as a type of enclosure that is constructed so that dusts will not enter the enclosing case under specific test conditions. In the NEC®, some applications for Class II, Division 1 require dust-ignitionproof enclosures.

In Article 506, the NEC® introduced the Zone Classification System, Zones 20, 21 and Zone 22 for Combustible Dust or Ignitable Fibers and Flyings, as an alternative to the Class and Division Classification System covered in Articles 500, 502 and 503.

The Zone Classification System is based on the modified IEC Area Classification System as defined in UL 60079-31.

METHODS OF PROTECTION (DUST)

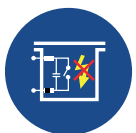

INTRINSIC SAFETY - TYPE OF PROTECTION iaD
INTRINSIC SAFETY - TYPE OF PROTECTION ibD
ASSOCIATED APPARATUS - TYPE OF PROTECTION [iaD] - UNCLASSIFIED
ASSOCIATED APPARATUS - TYPE OF PROTECTION [ibD] – UNCLASSIFIED



ENCAPSULATION - TYPE OF PROTECTION maD
ENCAPSULATION - TYPE OF PROTECTION mbD



PRESSURIZATION - TYPE OF PROTECTION pD



ENCLOSURE - TYPE OF PROTECTION T, TB, TC

Permitted Gas Techniques for Class I, Divisions		
Area Classification	Allowed Protection Types	Marking Type
Class I, Division 1	Intrinsically Safe	I.S., ia
	Encapsulation	ma
	Flameproof	da*
	EPL	Ga
	Explosionproof	
Class I, Division 2	All Class I, Division 1 Types	
	Flameproof	d or db
	Intrinsically Safe	ib
	Increased Safety	e or eb
	Pressurized	px, pxb, py, or pyb
	Encapsulation	m or mb
	Powder Filling	q or qb
	Oil Immersed	o or ob
	EPL	Gb
	Nonincendive	N.I.
	Pressurized	pz or pcz
	Intrinsically Safe	ic
	Increased Safety	ec
	Flameproof	dc
	Encapsulation	mc
	Protection Type ,n'	nC, nA, nR
	EPL	Gc
Apparatus marked for Class I, Div.2		

* da is limited to combustible gas detectors.

Permitted Gas Techniques for Zones		
Area Classification	Allowed Protection Types	Marking Type
(Class I), Zone 0	Intrinsically Safe	ia
	Encapsulation	ma
	Flameproof	da*
	EPL	Ga
(Class I), Zone 1	Explosionproof	
	Apparatus marked for Class I, Div.1	
	Flameproof	d or db
	Intrinsically Safe	ib
	Increased Safety	e or eb
	Pressurized	px, pxb, py, or pyb
	Encapsulation	m or mb
(Class I), Zone 2	Powder Filling	q or qb
	Oil Immersed	o or ob
	EPL	Gb
	Nonincendive	N.I.
	Pressurized	pz or pcz
	Intrinsically Safe	ic
	Increased Safety	ec
	Flameproof	dc
	Encapsulation	mc
	Protection Type ,n'	nC, nA, nR
EPL	Gc	
Apparatus marked for Class I, Div.2		

Permitted Dust Techniques for Class II, Divisions		
Area Classification	Allowed Protection Types	Marking Type
Class II, Division 1	Dust-Ignitionproof Enclosure	DIP
	Pressurization	Px, Py
	Intrinsically Safe	IS, ia, iaD
	Zone 20 Equipment	Ga
Class II, Division 2	Class II, Division 1 Protection	
	Dusttight Enclosure	
	Pressurization	Pz
	Intrinsically Safe	ib, ibD, ic, icD
	Zone 20, 21 or 22 Equipment	Ga, Gb, Gc

Permitted Dust Techniques for Zones		
Area Classification	Allowed Protection Types	Marking Type
Zone 20	Intrinsically Safe	ia, iaD
	Encapsulation	ma
	Dustproof Enclosure	ta
	EPL	Da
Zone 21	Intrinsically Safe	ib, ibD
	Encapsulation	mb
	Dustproof Enclosure	tb
	Pressurization	pxb, pyb, px, py
	EPL	Db
Zone 22	Zone 20 Equipment	
	Intrinsically Safe	ic, icD
	Encapsulation	mc
	Dustproof Enclosure	tc
	Pressurization	pzc, pz
	EPL	Dc
	Zone 20 or 21 Equipment	

ENVIRONMENTAL PROTECTION

NEMA AND CSA TYPE ENCLOSURE

02

NEMA or CSA Type 1 Enclosures – are intended for indoor use primarily to provide a degree of protection against limited amounts of falling dirt. This type is not specifically identified in the CSA Standard.

NEMA or CSA Type 2 Enclosures – are intended for indoor use primarily to provide a degree of protection against limited amounts of falling water and dirt.

NEMA or CSA Type 3 Enclosures – are intended for outdoor use primarily to provide a degree of protection against rain, sleet, windblown dust, and damage from external ice formation.

NEMA or CSA Type 3r Enclosures – are intended for outdoor use primarily to provide a degree of protection against rain, sleet, and damage from external ice formation, and must have a drain hole.

NEMA or CSA Type 3s Enclosures – are intended for outdoor use primarily to provide a degree of protection against rain, sleet, and windblown dust, as well as to provide for operation of external mechanisms when ice laden.

NEMA or CSA Type 4 Enclosures – are intended for indoor or outdoor use primarily to provide a degree of protection against windblown dust and rain, splashing water, hose directed water, and damage from external ice formation.

NEMA or CSA Type 4x Enclosures – are intended for indoor or outdoor use primarily to provide a degree of protection against corrosion, windblown dust and rain, splashing water, hose directed water, and damage from external ice formation.

NEMA or CSA Type 5 Enclosures – are intended for indoor use primarily to provide a degree of protection against settling airborne dust, falling dirt, and dripping non-corrosive liquids.

NEMA or CSA Type 6 Enclosures – are intended for indoor or outdoor use primarily to provide a degree of protection against hose-directed water, the entry of water during occasional temporary submersion at a limited depth, and damage from external ice formation.

NEMA or CSA Type 12 Enclosures – are intended for indoor use primarily to provide a degree of protection against circulating dust, falling dirt, and dripping non-corrosive liquids.

NEMA or CSA Type 6p Enclosures – are intended for indoor or outdoor use primarily to provide a degree of protection against hose-directed water, the entry of water during prolonged submersion at a limited depth, and damage from external ice formation.

NEMA or CSA Type 12k Enclosures – with knockouts are intended for indoor use primarily to provide a degree of protection against circulating dust, falling dirt, and dripping non-corrosive liquids.

NEMA or CSA Type 13 Enclosures – are intended for indoor use primarily to provide a degree of protection against dust, water spraying, oil, and non-corrosive coolant.

DEFINITIONS REFERRING TO NEMA REQUIREMENTS FOR HAZARDOUS LOCATION

The following NEMA type enclosures occasionally appear in specifications and product literature.

***NEMA 7 Enclosures** – are intended for indoor use in locations classified as Class I, Groups A, B, C, or D, as defined in the NEC®.

NEMA 8 Enclosures – are for indoor or outdoor use in locations classified as Class I, Groups A, B, C, or D, as defined in the NEC®.

***NEMA 9 Enclosures** – are intended for indoor use in locations classified as Class II, Groups E, F, and G, as defined in the NEC®.

NEMA 10 Enclosures – are constructed to meet the applicable requirements of the Mine Safety and Health Administration (MSHA).

* The designations are considered historically incomplete, at best. Types 7 and 9 are not mentioned anywhere in the National Electrical Code, the controlling document for installations. All hazardous location products must be marked with the Class, Division, Group, and Temperature Class to provide to an installer all of the information needed to complete an installation in accordance with Article 500 of the National Electrical Code.

Comparison of Specific Applications of Enclosure for Indoor Unclassified Location										
Provides a Degree of Protection Against the Following Environmental Conditions	Type of Enclosure									
	1*	2*	4	4X	5	6	6P	12	12K	13
Incidental Contact with the Enclosed Equipment	X	X	X	X	X	X	X	X	X	X
Falling Dirt	X	X	X	X	X	X	X	X	X	X
Falling Liquids and Light Splashing		X	X	X	X	X	X	X	X	X
Circulation Dust, Lint, Fibers, and Flyings**			X	X		X	X	X	X	X
Settling Airborne Dust, Lint, Fibers, and Flyings**			X	X	X	X	X	X	X	X
Hosedown and Splashing Water			X	X		X	X			
Oil and Coolant Seepage								X	X	X
Oil and Coolant Spraying and Splashing										X
Corrosive Agents				X						
Occasional Temporary Submersion						X	X			
Occasional Prolonged Submersion										

* These enclosures may be ventilated. However, Type 1 may not provide protection against small particles of falling dirt when ventilation is provided in the enclosure top.

** These fibers and flyings are not explosive materials and are not considered as Class III type ignitable fibers or combustible flyings. For Class III type ignitable fibers or combustible flyings see the National Electrical Code®, Article 500.

Comparison of Specific Applications of Enclosure for Outdoor Unclassified Location							
Provides a Degree of Protection Against the Following Environmental Conditions	Type of Enclosure						
	3*	3R*	3S	4	4X	6	6P
Incidental Contact with the Enclosed Equipment	X	X	X	X	X	X	X
Rain, Snow, Sleet*	X	X	X	X	X	X	X
Sleet**			X				
Windblown Dust	X		X	X	X	X	
Hosedown				X	X	X	
Corrosive Agents					X		
Occasional Temporary Submersion						X	
Occasional Prolonged Submersion							X

* External operating mechanisms are not required to operate when the enclosure is ice covered.

** External operating mechanisms are operable when the enclosure is ice covered.

*** These enclosures may be ventilated.

INGRESS PROTECTION (IP)

The IEC uses the term “Ingress Protection” to identify the environmental protection of a device. This is defined in IEC Standard 60529 and the following chart illustrates the two-digit code used.

Marking Pursuant to Standard Series IEC 61241 and IEC 60079					
IP: The IP Classification System Designates, by means of a Number the Degree of Protection Provided by a Device Against Ingress of a Dust and Water			SECOND NUMBER Degree of Protection Against Water		
FIRST NUMBER Degree of a Protection Against Solid Object					
0		Non-protected	0		Non-protected
1		Protected against a solid object greater than 50 mm such as a hand	1		Protected against water dripping vertically, such as condensation
2		Protected against a solid object greater than 12 mm, such as a finger	2		Protected against dripping water when tilted up to 15°
3		Protected against a solid object greater than 2.5 mm, such as wire or a tool	3		Protected against water spraying at an angle of up to 60°
4		Protected against a solid object greater than 1.0 mm, such as wire or thin strips	4		Protected against water splashing from any direction
5		Dust-protected. Prevents ingress of dust sufficient to cause harm	5		Protected against jets of water from any direction
6		Dusttight. No dust ingress.	6		Protected against heavy seas or powerful jets of water
			7		Protected against harmful ingress of water when immersed between a depth of 150 mm to 1 meter
			8		Protected against submersion. Suitable for continuous immersion in water, based on marked depth.

NOTE: Protection type x7 & x8 do not include protection x6 (or lower).

EQUIPMENT CERTIFICATION

02

Equipment for use in hazardous locations must be certified to an appropriate National Standard and marked as such by an accredited third-party testing organization. Follow-up inspection to ensure conformance is part of the program. Products may carry multiple markings for multiple countries. The following is a brief description of the National Requirements.

IMPORTANT LISTING INFORMATION

The specific requirements for product certification vary from country to country. While UL, FM and CSA are similar in their approach, subtle differences still exist.

North American certifications permit conduit or cable entries to be field installed provided appropriate bonding and grounding requirements are followed.

Marking

Typical U.S. Marking to NEC® 500 (Gas)

Class I, Division 1 **Group A, B, C, D** **T4**

Group

Apparatus Group		
II Surface Industries	A	Propane
	B	Ethylene
	C	Hydrogen
	D	Acetylene

Max. Surface Temperature

Temperature	
T4	135°C

Marking

Classification	
Class I	Gases and Vapors
Division 1	Level of Hazard
Division 2	Level of Hazard

Typical U.S. Marking to NEC® 500 (Dust)

Class II, Division 1 **Group E, F, G** **T4**

Group

Apparatus Group		
II Surface Industries	E	Metal Dusts
	F	Carbonaceous Dusts
	G	Agricultural Dust

Max. Surface Temperature

Temperature	
T4	135°C

Marking

Classification	
Class II	Combustible Dusts
Division 1	Level of Hazard
Division 2	Level of Hazard

Typical U.S. Marking to NEC® 505

Certified against UL 60079

Class I, Zone 1 **AEx** **db eb** **IIC** **T4** **Gb**

Group

Apparatus Group		
II Surface Industries	C	Hydrogen & Acetylene

Max. Surface Temperature

Temperature	
T4	85°C

Methods of Protection

See pages 21-24

Equipment Protection Level (EPL)

Classification	Zone 0	Zone 1	Zone 2
(UL CSA C 22.2 No.) 60079-0	Ga	Gb	Gc

Marking

Classification	
Class I	Gases and Vapors
Zone 0	Areas where explosive gas atmosphere is continuously present or present for long periods of time
Zone 1	Areas where explosive gas atmosphere is likely to occur in normal operation or can be expected to be present frequently
Zone 2	Area where explosive gas atmosphere is not likely to occur and if it does, it will only exist for a short period of time

Typical U.S. Marking to NEC® 506

Certified against UL 60079

Zone 21 **AEx** **tb** **IIC** **T120°** **Db**

Group

Apparatus Group		
Typical Material	IIC	Metal Dust

Max. Surface Temperature

Temperature	
T120°	120°C

Methods of Protection

See pages 21-24

Equipment Protection Level (EPL)

Classification	Zone 20	Zone 21	Zone 22
(UL / CSA C27.2 No.) 60079-0	Da	Db	Dc

Marking

Classification	
Zone 20	Area where combustible dust clouds are likely to occur during normal operation
Zone 21	Areas where explosive dust atmosphere is likely to occur in normal operation or can be expected to be present frequently
Zone 22	Area where explosive dust atmosphere is not likely to occur and if it does, it will only exist for a short period of time

Typical Canadian Marking to SEC 18 (Gas)

Certified against CSA C22.2 No. 60079

Ex db eb IIC T6 Gb

Group

Apparatus Group

II Surface Industries	C	Hydrogen + Acetylene
-----------------------	---	----------------------

Max. Surface Temperature

Temperature

T6	85°C
----	------

Methods of Protection

See pages 21-24

Equipment Protection Level (EPL)

Classification	Zone 0	Zone 1	Zone 2
(UL / CSA C22.2 No. 60079-0)	Ga	Gb	Gc

Typical Canadian Marking to ANNEX J (Gas)

Class I, Division 1 Group A, B, C, D T4

Group

Apparatus Group

II Surface Industries	A	Propane
	B	Ethylene
	C	Hydrogen
	D	Acetylene

Max. Surface Temperature

Temperature

T4	135°C
----	-------

Marking

Classification

Class I	Gases and Vapors
Division 1	Level of Hazard
Division 2	Level of Hazard

Typical Canadian Marking to ANNEX J (Dust)

Class II, Division 1 Group E, F, G T4

Group

Apparatus Group

II Surface Industries	E	Metal Dusts
	F	Carbonaceous Dusts
	G	Agricultural Dusts

Max. Surface Temperature

Temperature

T4	135°C
----	-------

Marking

Classification

Class II	Combustible Dusts
Division 1	Level of Hazard
Division 2	Level of Hazard

Typical IEC Marking (Gas)

Certified against IEC 60079

Ex **db eb** **IIC** **T4** **Gb**

Group

Apparatus Group		
II Surface Industries	C	Hydrogen + Acetylene

Methods of Protection

See pages 21-24

Max. Surface Temperature

Temperature	
T4	125°C

Equipment Protection Level (EPL)

Classification	Zone 0	Zone 1	Zone 2
IEC 60079-0	Ga	Gb	Gc

Typical IEC Marking (Dust)

Certified against IEC 60079

Ex **tb** **IIIC** **T4** **Db**

Group

Apparatus Group		
Typical Material	IIIC	Metal Dust

Methods of Protection

See pages 21-24

Max. Surface Temperature

Temperature	
T4	135°C

Equipment Protection Level (EPL)

Classification	Zone 20	Zone 21	Zone 22
IEC 60079-0	Ga	Gb	Gc

Typical European Marking (Gas)

Marking as directed per ATEX Directive 94/9/EC 2014/34/EU

Ex II 2G **Ex** db eb IIC T6 Gb

Group

Apparatus Group

II Surface Industries	C	Hydrogen + Acetylene
-----------------------	---	----------------------

Max. Surface Temperature

Temperature

T4	85°C
----	------

Methods of Protection

See pages 21-24

Equipment Protection Level (EPL)

Classification	Zone 20	Zone 21	Zone 22
En 60079-0	Ga	Gb	Gc

Marking

Classification

Class II	Surface
Zone 0 (1)	Areas where explosive gas atmosphere is continuously present or present for long periods of time.
Zone 1 (2)	Areas where explosive gas atmosphere is likely to occur in normal operation or can be expected to be present frequently
Zone 2 (3)	Area where explosive gas atmosphere is not likely to occur and if it does, it will only exist for a short period of time

Typical European Marking (Dust)

Marking as directed per ATEX Directive 94/9/EC 2014/34/EU

Ex II 2D **Ex** tb IIC T120° Db

Group

Apparatus Group

Typical Material	IIC	Metal Dust
------------------	-----	------------

Max. Surface Temperature

Temperature

T120°	120°C
-------	-------

Methods of Protection

See pages 21-24

Equipment Protection Level (EPL)

Classification	Zone 20	Zone 21	Zone 22
En 60079-D	Ga	Gb	Gc

Marking

Classification

Zone 20 (1)	Areas where explosive gas atmosphere is continuously present or present for long periods of time.
Zone 21 (2)	Areas where explosive gas atmosphere is likely to occur in normal operation or can be expected to be present frequently
Zone 22 (3)	Area where explosive gas atmosphere is not likely to occur and if it does, it will only exist for a short period of time

EQUIPMENT PROTECTION LEVEL (EPL)

EPL is the level of protection assigned to equipment based on its likelihood of becoming a source of ignition and distinguishing the differences between explosive gas atmospheres, explosive dust atmospheres, and the explosive atmospheres in mines susceptible to firedamp.

02

EPL for Gas		
EPL	Location Usage	Definition
Ga	Zone 0	Equipment for explosive gas atmospheres, having a “very high” level of protection, which is not a source of ignition in normal operation, during expected malfunctions or during rare malfunctions.
Gb	Zone 1	Equipment for explosive gas atmospheres, having a “high” level of protection, which is not a source of ignition in normal operation or during expected malfunctions.
Gc	Zone 2	Equipment for explosive gas atmospheres, having a “enhanced” level of protection, which is not a source of ignition in normal operation and which may have some additional protection to ensure that it remains inactive as an ignition source in the case of regular expected occurrences (for example, failure of a lamp).

EPL for Dust		
EPL	Location Usage	Definition
Da	Zone 20	Equipment for explosive dust atmospheres, having a “very high” level of protection, which is not a source of ignition in normal operation, during expected malfunctions or during rare malfunctions.
Db	Zone 21	Equipment for explosive dust atmospheres, having a “high” level of protection, which is not a source of ignition in normal operation or during expected malfunctions.
Dc	Zone 22	Equipment for explosive dust atmospheres, having a “enhanced” level of protection, which is not a source of ignition in normal operation and which may have some additional protection to ensure that it remains inactive as an ignition source in the case of regular expected occurrences (for example, failure of a lamp).

EPL for Mining		
EPL	Location Usage	Definition
Ma	Group I	Equipment for installation in a mine susceptible to firedamp, having a “very high” level of protection, which has sufficient security that is unlikely to become an ignition source in normal operation, during expected malfunctions, or during rare malfunctions, even when left energized in the presence of an outbreak of gas.
Mb	Group I	Equipment for installation in a mine susceptible to firedamp, having a “high” level of protection, which has sufficient security that is unlikely to become a source of ignition in normal operation or during expected malfunctions in the time span between there being an outbreak of gas and the equipment being de-energized.

Notes: Ma and Mb are for particular use in Underground Mines. There is not a Mc Protection Level.

ATEX DIRECTIVE

The ATEX Directive 94/9/EC 2014/34/EU is a directive adopted by the European Union (EU) to facilitate free trade in the EU by aligning the technical and legal requirements in the member states for products intended for use in potentially explosive atmospheres. This Directive applies to electrical and non-electrical equipment/components and protective systems. The ATEX Directive became mandatory on July 1, 2003.

Equipment located outside potentially explosive atmospheres are also covered by the ATEX Directive under the following conditions:

- The equipment is a safety device, controller or regulatory device and
- The equipment is required for the safe function of equipment or protective systems with respect to the risk of explosion.

All equipment under its scope is required to bear the European CE Marking as verification of compliance with the Directive (the CE Marking will not appear on components defined by this Directive). The ATEX Directive specifically defines procedures for the evaluation of a product's design and production based on Equipment Groups and Categories. This is briefly outlined below.

EQUIPMENT GROUP I OVERVIEW

Equipment intended for use in underground parts of mines, and in those parts of surface installations of such mines that are liable to be endangered by firedamp and/or combustible dust.

EQUIPMENT GROUP II OVERVIEW

Equipment intended for use in locations other than those listed under Equipment Group I, that are liable to be endangered by explosive atmospheres.

Equipment Group for Mines Susceptible to Firedamp		
Equipment Category	Protection	Comparison to Current IEC Classification
M1	2 Levels of Protection or 2 Independent Faults	Group I
M2	1 Level of Protection Based on Normal Operation	Group I

Equipment Group for Surface Locations		
Equipment Category	Protection	Comparison to Current IEC Classification
1G 1D	2 Levels of Protection or 2 Independent Faults	Group II, Zone 0 (Gas) Zone 20 (Dust)
2G 2D	1 Level of Protection Based on Frequent Disturbances or Equipment Faults	Group II, Zone 1 (Gas) Zone 21 (Dust)
3G 3D	1 Level of Protection Based on Normal Operation	Group II, Zone 2 (Gas) Zone 22 (Dust)

ATEX MARKING

The equipment for ATEX identifies the category that indicates the level of risk of the equipment becoming a source of ignition. The table on the right shows the relationship between Categories and Zones. Note that the Zone represents only the risk of flammable materials being released into the area.

NOTE: As an alternative to the relationship given in the table on the right between Categories and Zones, the required Category of equipment may be selected on the basis of risk, i.e. taking into account the consequences of an ignition. This may, in certain circumstances, require a higher Category or permit a lower Category than defined in the table.

Zone	Categories
0	1G
1	2G
2	3G
20	1D
21	2D
22	3D

DIFFERENCES BETWEEN THE OLD AND NEW DIRECTIVES

The main differences are:

The inclusion of non-electrical equipment, additional quality system requirements, the inclusion of dust atmospheres, the need to produce a 'Technical File', requirements for safety-related devices (flame arrestors, suppression systems, etc) and safe area equipment.

PRODUCTS COVERED

The Directive, however, does exclude the following product types:

- Medical devices
- Sea-going vessels and mobile offshore units
- Products for use in the presence of explosives
- Military equipment
- Products for domestic use
- Personal protective equipment covered by directive 89/686/EEC
- Means of transport by air or on road or rail or water networks

Vehicles intended for use in an explosive atmospheres are not excluded. For more info about ATEX, visit www.ec.europa.eu/growth/sectors/mechanical-engineering/atex_en

IECEX SCHEME

The objective of the IECEx Scheme is to facilitate global trade in electrical equipment intended for use in explosive atmospheres by eliminating the need for multiple national certifications.

The IECEx Scheme provides the means for manufacturers of Ex equipment to obtain certificates of conformity that will be accepted at the national level in all participating countries. A certificate of conformity may be obtained from any certification body accepted into the Scheme. The certificate will attest that the equipment design conforms to the relevant IEC Standards. The final objective of the IECEx Scheme is worldwide acceptance of one standard, one certificate and one mark.

For the IECEx Scheme to achieve its long term objective, every national Standard for which application is made by participating countries will need to be identical to the corresponding IEC Standard. For countries whose national Standards are not yet identical to the IEC Standards, a transitional period will be necessary to allow time member countries participating in the IECEx Scheme to adjust their national standards to the IEC standards and work toward national acceptance of IECEx Certificates of conformity and the IECEx mark.

For more info about the IECEx Scheme, visit www.IECEx.com

INTRINSIC SAFETY OVERVIEW

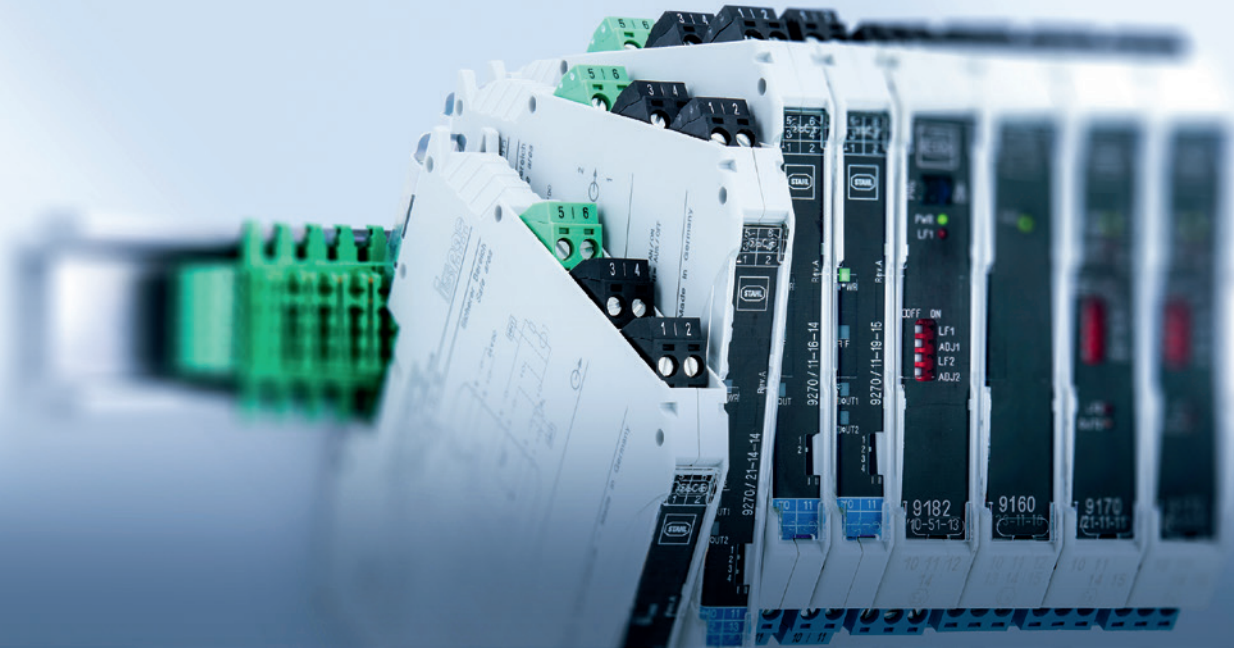

Product	Series	Page	WebCode
Intrinsic Safety Overview			
Benefits of I.S. Systems, I.S. Loop Components		39	
Energy Limiting Methods of Protection for Division 2		44	
Installation of Intrinsically Safe Systems		41	
Intrinsic Safety Interface Selection		42	
Intrinsic Safety Loop Verification		40	
Introduction to Intrinsic Safety		38	

For additional products and information please refer to r-stahl.com

INTRINSIC SAFETY OVERVIEW

03

INTRODUCTION TO INTRINSIC SAFETY

Intrinsic safety (I.S.) is a method of protection based upon limiting both electrical and thermal energy under normal and abnormal conditions that can flow in the hazardous area. This limited energy will never be enough to ignite the explosive atmosphere. Due to the limited amount of energy that can flow in this type of circuit, field devices like pressure transmitters, level sensors, proximity sensors, solenoids, and other I.S. rated field devices are the typical application used for I.S. installations. With an I.S. installation, there is no need of any special flameproof or pressurized enclosure design to be installed in the hazardous area because the method of protection relies on the limitation of energy and not on mechanical protection.

On an I.S. installation, it is imperative for a supply device to form an electrical loop by connecting to a field device (load) through the wires. Therefore, to create an I.S. loop, it is essential for an I.S. field device to be connected to an I.S. associated apparatus such as zener barriers or galvanic isolator barriers. It is important to perform energy calculations to confirm that an I.S. loop has been created.

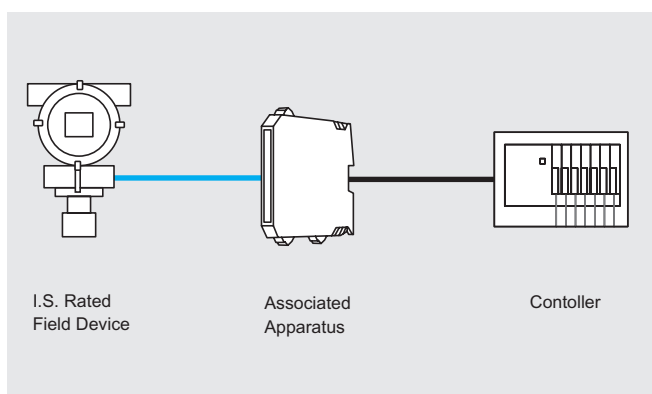

1. BENEFITS OF I.S. SYSTEMS

When I.S. technology and installations are used, a hot swap of devices in their live condition is safe and allowed by the procedures. This means the hot work is possible and no plant down time is required to perform maintenance tasks during the operation.

The wiring and termination used in the I.S. loop do not need to carry their own hazardous area certification to ensure safety, as the safety of the loop relies on the I.S. barrier and I.S. field device. This means that general-purpose wiring is allowed in this type of I.S. loop, and these wires and connectors can be industrial in type.

2. I.S. LOOP COMPONENTS

In the next few sections, we will define each component in an I.S. loop and energy calculations accordingly.

A typical I.S. system consists of an associated apparatus, intrinsically safe electrical apparatus, and interconnecting wiring. When the system is properly installed, the incidence of spark-causing conditions such as electrical equipment failure, wrong wiring, overvoltage application to the circuit, or the grounding, shorting or open-circuitry of any lead(s) in the presence of a hazardous mixture shall not be of sufficient energy to cause ignition.

The standards relative to intrinsic safety include three types of apparatus:

- Associated apparatus
- Intrinsically safe electrical apparatus
- Simple apparatus

2.1 ASSOCIATED APPARATUS

An associated apparatus is a device that has I.S. circuits on one side and non-I.S. circuits on the other. These devices connect their I.S. circuit to the field device circuits. The associated apparatus limits the power to intrinsically safe energy levels allowing the device to be introduced into the hazardous location. Several associated apparatus options are available. R. STAHL offers Remote I/O with built-in galvanic isolator barriers and Foundation Fieldbus with built-in galvanic isolator barriers, galvanic isolator barriers (also known as isolator barriers) and safety zener barriers (also known as zener barriers).

All associated apparatuses will have a set of values defined as entity parameters (safety values) and operational parameters (nominal values). Entity parameters shall be considered the

highest amount of energy that the associated apparatus can pass to the hazardous area under normal and abnormal conditions. Operational parameters can be considered the amount of energy that has to be provided for power-up and operation of the electrical apparatus (field devices).

An associated apparatus always requires a certification by the Authority Having Jurisdiction (AHJ).

2.2 INTRINSICALLY SAFE ELECTRICAL APPARATUS

Field devices being used in an I.S. application need to have a third-party certification that rates them as I.S. field devices. Such devices include transmitters, positioners, solenoid valves, among others. We still need to connect a simple apparatus to an associated apparatus to create an I.S. loop. The field devices are designed and built as per I.S. circuit standards. These devices have to be submitted to a Nationally Recognized Test Lab (NRTL) and tested against the I.S. standard of that jurisdiction. Once the device passes the test, the NRTL will provide the paperwork identifying the specific manufacturer, model number, and wiring requirements. In North America, control drawings are part of the NRTL certification package and provide valuable information about installation and wiring conditions required to comply with the code.

Just like the associated apparatus, the I.S. field device will have a set of values defined as entity parameters (or safety data) and operational parameters. Entity parameters shall be considered the highest amount of energy that can be received in normal and abnormal conditions and will not cause a spark or heat release sufficient enough to react with the explosive atmosphere. Operational parameters can be considered the amount of energy required for the field device to power-up and work during normal operation.

2.3 SIMPLE APPARATUS

There are just a handful of field devices that can be used in an I.S. loop and do not need to be certified by a NRTL. The NEC® defines them as simple apparatus in section NEC® 504.2 as devices that cannot generate or store more than 1.5 V, 100 mA, 25 mW, and 20 µJ. Some examples include mechanical switches, RTDs, thermocouples, and load cells. It is necessary to confirm with the manufacturer of the device that such a device is considered a simple apparatus. Assumptions should not be made. Since these devices cannot contribute energy of sufficient magnitude to ignite a hazardous mixture under a fault condition, they can be connected to a certified I.S. circuit via an associated apparatus. The evaluation by a testing agency includes the connection of a simple apparatus to an I.S. circuit from an associated apparatus.

3. INTRINSIC SAFETY LOOP VERIFICATION

Associated apparatuses are evaluated to establish the maximum energy levels that can be discharged through their circuits under fault conditions. These faults include open or short circuits and grounding, and grounding of the intrinsically safe leads. The information is represented in the form of entity parameters (safety data) and consists of some combination of the following values:

- Open circuit voltage, $V_{oc}(U_o)$ or V_t
- Power transfer, P_o
- Short circuit current, $I_{sc}(I_o)$ or I_t
- Allowable external inductance, $L_a(L_o)$
- Allowable external capacitance, $C_a(C_o)$

Those products designed to be connected to an intrinsically safe circuit, such as transmitters, positioners, etc., are evaluated for the maximum voltage and current they can withstand before internal component failures begin, resulting in an excessive buildup of heat and subsequent ignition of the surrounding hazardous fuel-air mixture. They are also evaluated for the amount of internal energy-storing components (capacitance and inductance) that may be discharged under predefined fault conditions.

Under the entity concept, the intrinsically safe electrical apparatus will be assigned entity parameters that, when properly matched to those of an associated apparatus, will constitute an intrinsically safe system (I.S. loop). Such values include the following:

- Maximum voltage, $V_{max}(U_i)$
- Maximum current, $I_{max}(I_i)$
- Maximum power, P_{max}
- Total unprotected capacitance, C_i
- Total unprotected inductance, L_i

3.1 COMPARISON OF ENTITY PARAMETERS

An I.S. loop is created when the following rules are applied:

I.S. Field Device	Cable		Associated Apparatus
$V_{max}(U_i)$		\geq	$V_{oc}(U_o)$
$I_{max}(I_i)$		\geq	$I_{sc}(I_o)$
P_i		\geq	P_o
C_i	$+ C_{cable}$	\leq	$C_a(C_o)$
L_i	$+ L_{cable}$	\leq	$L_a(L_o)$

Entity parameters can be found in the NRTL documentation of the associated apparatus as well as on the I.S. field device. Certain other considerations, such as certified temperature range or electrostatic additional protection methods, often need to be addressed. Given these special considerations, we always

encourage reading the instruction manuals, reviewing the product certifications, and referring to the control drawings.

3.2 INTERCONNECTING WIRING

Interconnecting wiring can store energy that could, under normal or fault conditions, at some point react with an explosive atmosphere. Consequently, interconnecting wiring between the associated apparatus and I.S. field device (or simple apparatus) needs to be taken into consideration when an I.S. loop is built. If available, the actual capacitance and inductance values for the specific wires being used should be referenced. If these are not available, values of 60 pF/foot for capacitance per wire pair and 0.2 μ H/foot for inductance are accepted and may be used for the cable length calculation.

4. INSTALLATION OF INTRINSICALLY SAFE SYSTEMS

With the correct associated apparatus (interface) selected, the installation phase may begin. In general, the requirements for the installation of intrinsically safe systems are more flexible than those of explosionproof or purged systems. The user should have good knowledge of the National Electrical Code with specific focus on Articles 504 and 505, which deal with intrinsically safe systems. Since there are differences in the equipment provided by different companies, R. STAHL recommends that the user reviews the installation requirements. This can vary among different locations based on local codes and enforcement. Another valuable source of information is the ANSI/ISA RP-12.6 document available through the ISA organization. The user should also refer to the control drawings supplied by the manufacturer of both the associated and the intrinsically safe apparatuses.

The associated apparatus itself is normally installed in the nonhazardous location using general-purpose enclosures or panels. However, if space is not available in the safe area or physical plant layout requires installation at the hazardous location, rated associated apparatus can be used and installed in hazardous areas, such as our INTRINSPAK and ISPac for Class I, Division 2 applications and IS1+ Remote I/O for Zone 1, Class I, Division 1 & 2.

The wiring between the associated apparatus and the intrinsically safe apparatus may be installed using any of the protection methods suitable for unclassified locations, with the exceptions noted below. For example, it is acceptable to use PLTC cable run in the open cable trays or raceways, along with general-purpose junction boxes.

1. Intrinsically safe wiring not run in raceways or cable trays shall be separated and secured from non I.S. wiring by at least 2 inches (50 mm). Exception: when Type MI or MC cables are used and properly grounded.
2. Intrinsically safe wiring shall never be placed in raceway or cable trays with nonintrinsically safe wiring unless they are separated by at least 2 inches (50 mm) using tie downs, grounded metal partitions, or approved insulating partition.
3. Intrinsically safe wiring in enclosures shall be separated by at least 2 inches (50 mm) and secured to prevent inadvertent contact. Wiring ducts may be used provided they maintain a 3/4 inch (19 mm) separation between intrinsically safe and nonintrinsically safe wiring.
4. Different intrinsically safe circuits shall be run in separate cables or separated by either a grounded shield or insulation with a minimum thickness of 0.01 inches (254 μ m).
5. Intrinsically safe wiring shall be identified as such with labels placed no more than 25 feet (7.62 m) apart. Terminals shall be identified as well.
6. The color light blue is recognized internationally as identifying intrinsically safe wiring. It is recommended that cables, terminal blocks, raceways, cable ducts, and junction boxes entries be light blue in color.
7. Gastight seals shall be used where intrinsically safe wiring transitions hazardous location boundaries.
8. Intrinsically safe, associated apparatus, cable shields, enclosures, and raceways (metal) shall be grounded in accordance with the requirements of Section 250 of the NEC®.
9. Nonhazardous location electrical equipment must not contain a source voltage greater than 250 V unless sufficient means have been employed to prevent the shorting of a source voltage greater than 250 V onto the intrinsically safe terminals of the associated apparatus.

10. As all wiring contains stored energy (capacitance and inductance), all conductors must be considered when determining the length of intrinsically safe circuits. When available, the actual values of capacitance and inductance for the specific wire being used should be referenced. If these are not available, values of 60 pF/foot for capacitance per wire pair and 0.2 μ H/foot for inductance are accepted and may be used.

11. To ensure correct operation of a zener barrier installation under fault conditions, the system must have an insulated, properly maintained, independent, low impedance I.S. ground connection. This is a connection from the barrier busbar to the star point (A) of the incoming power supply through which no supply system current flows.

12. The ground conductor of a zener barrier must be < 1 Ohm minimum 12 AWG (4 mm²) and connected using shakeproof terminals. It should also be secure, visible, clearly identified and accessible for routine inspections and maintenance. Additional information is available on ISA 12.6.

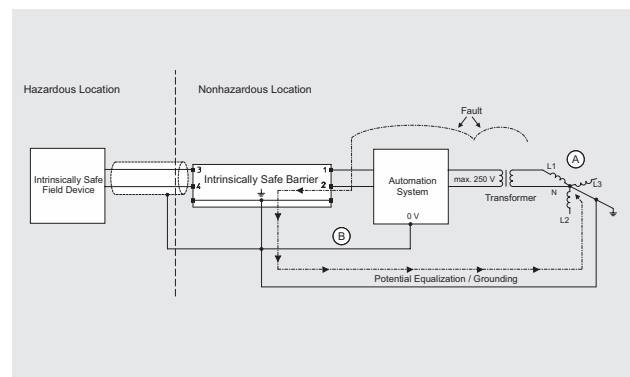

Typical installation of an intrinsically safe system, using a zener diode type of associated apparatus. The I.S. ground conductor is not necessary when using an I.S. galvanic isolator barrier or other type of associated apparatus.

13. To prevent potential differences on a zener barrier and ensure correct operation under normal conditions, it is also advisable to connect the barrier busbar to the common / 0 V (B) of the equipment in the nonhazardous location.
14. In the hazardous location, all cables should be grounded at one point only, and we recommend that this be at the barrier busbar.
15. Where shielded cables are used, they must be bonded to ground and taped back. For installation options, please refer to the ISA 12.6 standard.

5. INTRINSIC SAFETY INTERFACE SELECTION

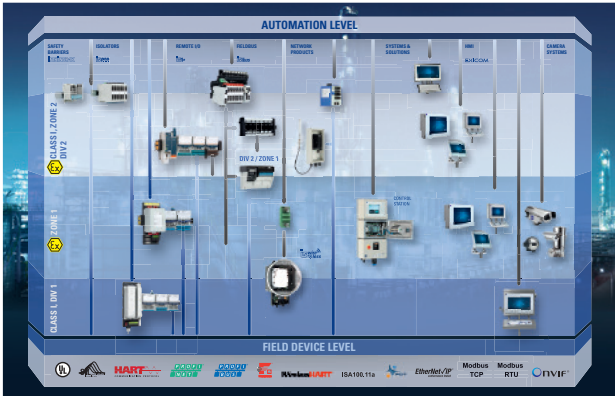

R. STAHL portfolio of Automation components.

Once the instrumentation/field devices have been specified as intrinsically safe, the selection of an associated apparatus must be done accordingly. R. STAHL offers four technologies: zener barriers, isolator barriers, Remote I/O, and Foundation Fieldbus.

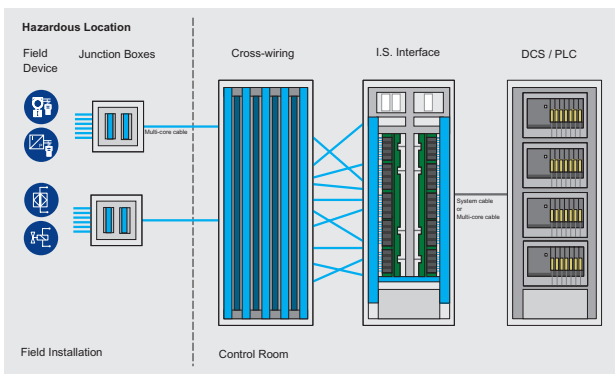

Typical point to point installation using Zener barriers or Galvanic isolator barriers.

Zener barriers and isolator barriers use an approach known as point-to-point (or classic approach). Here, a loop starts at the DCS/PLC card and ends at the field device. Typically, each loop has a pair of wires and extends from the safe area to the hazardous location.

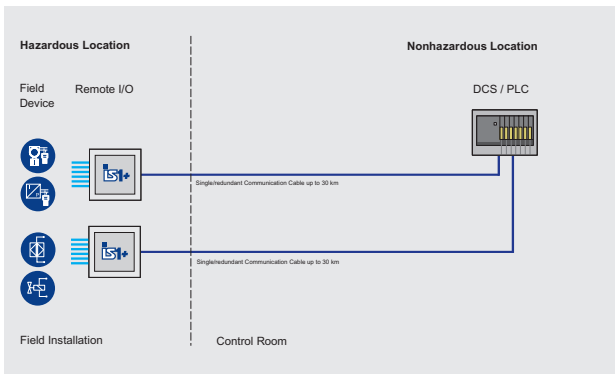

Point to bus installation using hazardous rated remote I/O system.

A Remote I/O uses an approach known as point-to-bus. Here, a DCS/PLC has a communication card (H1, Modbus TCP, Ethernet IP, etc.) and a digital bus runs from the safe area into the hazardous location where a Remote I/O station or field device coupler provides individual connections to the field devices. This approach has many advantages over point-to-point. The main four advantages are:

1. Minimizing the wiring
2. Minimizing the installed equipment hence faster commissioning and cost-efficient solutions
3. Providing diagnostic information of wiring and hardware
4. Reducing engineering work due to digital communication and the number of cables and terminations

5.1 ZENER BARRIERS



This is one of the first types of associated apparatus created. It is a passive device with essentially three safety components – a fuse, a resistor and zener diodes. These components have specific ratings and ensure that high amounts of energy cannot flow into the hazardous area.

Zener barriers are cost-effective solutions. They are also very compact devices and do not require an external source of power to work (loop powered). However, due to the fact that the devices are passive, they are more susceptible to outside factors like noise. Also, the built-in resistor creates a voltage drop that needs to be taken into consideration when selecting the right zener barrier for the application (operational parameters). Lastly, all zener barriers need to be grounded. This ground is a critical part of the I.S. protection and must be performed in accordance with the standards ISA 12.6 , CEC and NEC® 504.5 Zener barriers are still popular for some applications that require the passive element approach such as load cells and some sensors that work with voltages lower than 24 V (12 V applications, for example) or AC voltage. They are also required for sensors that provide a frequency closer to 100 kHz.

R. STAHL family of zener barriers is known as INTRISPAK and is explained in Chapter 8 of this catalog.

5.2 ISOLATOR BARRIERS

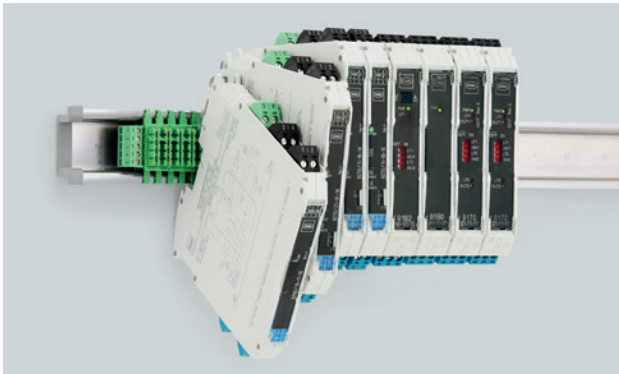

These associated apparatus not only provide I.S. power into the field, but can also serve as signal conditioners. These are considered active devices and have several electronics on it to achieve the conditioning of the signal as well as the I.S. power. These devices are less susceptible to noise and do not require a dedicated ground connection. They do require an independent source of power, however.

Isolator barriers are slightly larger than zener barriers in size. However, nowadays it is easy to find dual channel isolator options, which reduce the real state footprint. External power is still required, but certain accessories have been developed to reduce the wiring requirements for this external power source. Lastly, selecting an isolator barrier is easier than a zener barrier, as these are designed specifically for classic applications, such as analog inputs, analog outputs, digital inputs, digital outputs and temperature measurements. There are other types of isolator barriers available for serial and Ethernet based bus communication.

The R. STAHL family of isolator barriers is known as ISpac. Refer to Chapter 7 for product information.

5.3 REMOTE I/O WITH BUILT-IN ISOLATOR BARRIERS



This type of associated apparatus not only provides an I.S. signal in the field, but can also be installed in hazardous location areas closer to field devices, even in Class I, Division 1 classified areas. When this concept is used, both wiring and energy loss will be significantly reduced. In addition, when the R. STAHL Remote I/O solution is used, no flameproof or purged enclosures are required. A Remote I/O station will have I/O cards with built-in isolator barriers and a gateway that digitalizes the information from the I/O cards and sends it via a communication bus (like Ethernet IP or Profibus DP) to a communication card on the PLC/DCS. Besides reducing wiring and minimizing the space in the safe area, the Remote I/O stations also provide preventive maintenance diagnostic information.

The selection of the I/O cards is very simple as the cards are designed specifically for classic applications, such as analog inputs, analog outputs, digital inputs, digital outputs and temperature inputs. Also, the cards are multichannel and multifunctional, which means the channels can be independently configured for inputs or outputs and in some cases even for digital or analog (restrictions may apply for combinations).

The R. STAHL family of Remote I/O is known as IS1+. Refer to Chapter 6 for product information.

5.4 FOUNDATION FIELDBUS WITH BUILT-IN ISOLATOR BARRIERS

This type of associated apparatus is required only when the DCS communication card is an FF H1 and the field devices are known to be FF certified as well as I.S. certified.

R. STAHL follows the high power trunk concept in which the intrinsic safety loop starts at the spur. The system consists of its own FF power supplies, as well as the couplers, which can be rated for hazardous locations such as Class I, Division 2 installations with or without I.S. outputs.

The R. STAHL family of Foundation Fieldbus is known as ISbus. Refer to Chapter 9 for product information.

6. ENERGY LIMITING METHODS OF PROTECTION FOR DIVISION 2

Under the protection technique concept known as energy release limitation, there are two approaches – intrinsic safety and nonincendive. The two approaches are similar in basic principle but have two major differences.

The first difference is that nonincendive circuits and devices are only evaluated under normal conditions so no faults need to be considered. Any equipment that meets the criteria for nonincendive can only be used in Class I, II or III, Division 2 locations. On the other hand, I.S. equipment can be used in Class I, II, III, Division 1 and 2 based on certification.

The second difference is that the connection to an associated apparatus and the entity parameter analysis is not required in all cases (refer always to the field device control drawing for confirmation). This depends on the way in which the field device is certified. A concept we will introduce in the next section constitutes the difference between nonincendive field wiring and nonincendive equipment.

An additional difference between intrinsic safety and nonincendive is that live maintenance is not permitted for nonincendive installations.

6.1 NONINCENDIVE EQUIPMENT

For equipment to be listed as nonincendive it has to be assessed and tested under normal conditions by a third-party agency and certified as a nonincendive field device. The assessment and testing for thermal conditions is also conducted under normal conditions. Normal conditions include extremes of supply rating, ambient temperature rating and operator adjustments. Nonincendive devices are rated for Class I, II or III, Division 2.

If the field device has been approved as nonincendive equipment, it can be installed in a Class I, Division 2 area and be connected to a piece of equipment in the nonhazardous location that has no approvals using the cable types listed below and following the installation guidelines in the NEC® Article 501-4(b) 501.10.

- All wiring methods approved for Class I, Division 1, Zone 1
- Rigid metal conduit (RMC) and intermediate metal
- Enclosed gasket busways/wireways
- Type PLTC and Type PLTC-ER cable as per Article 725
- Type ITC and Type ITC-ER cable as per Article 727.4
- Type MC, MV, TC, or TC-ER cable
- Flexible connections such as flexible metal fittings are permitted for areas of limited space
- Liquidtight flexible nonmetallic conduit and flexible cord (where permitted)

Disconnection in the classified area when energized is not acceptable.

6.2 NONINCENDIVE FIELD WIRING (NIFW)

A concept called nonincendive field wiring methods (NIFW) also exists, that is different from nonincendive field devices. As with intrinsic safety, NIFW concept can be applied with a cable that is suitable for use in nonhazardous locations. The associated nonincendive field wiring apparatus and the nonincendive field wiring field device both have parameters associated with them which are shown on the control drawing and must be installed per the control drawing.

Nonincendive Field Wiring Apparatus		Associated Nonincendive Field Wiring Apparatus
$V_{max}(U_i)$	\geq	$V_{oc}(U_o)$
$I_{max}(I_i)$	\geq	$I_{sc}(I_o)$
$C_i + C_{cable}$	\leq	$C_a(C_o)$
$L_i + L_{cable}$	\leq	$L_a(L_o)$

At this point, the entity concept for both intrinsic safety and nonincendive field wiring looks the same, but yet it is not. In both applications, a controller controls either the voltage or current or both values. For NIFW, the respective non-controlled value needs to be greater than or equal to that supplied by the associated nonincendive field wiring apparatus (see the above table). For example, when it is connected to a 4/20 mA transmitter, this unit controls the current, so the current parameter does not need to be evaluated. In these instances, the control drawing should be checked to find details of the connections permitted.

6.3 DIVISION 2 INTERFACE SELECTION

Once the instrumentation/field devices have been specified as nonincendive or Division 2 rated, an interface needs to be selected. R. STAHL offers one main technology for this. The wiring has been defined as NIFW so that nonhazardous-rated wiring can be used, an associated apparatus needs to be selected. R. STAHL also offers one main technology for this.

03

Remote I/O uses an approach known as point-to-bus. Here, a DCS/PLC has a communication card (Modbus TCP, Profibus, etc.) and a bus (a pair of wires) that go from the safe area into the hazardous location where a Remote I/O station provides individual connections to the field devices. This approach has many advantages over point-to-point. The main four advantages:

1. Minimizing the wiring
2. Minimizing the installed equipment hence faster commissioning and cost-efficient solutions
3. Providing diagnostic information of wiring and hardware
4. Reducing engineering work due to digital communication and the number of cables and terminations

The Remote I/O with the nonincendive associated apparatus can be installed in a hazardous location like Class I, II, Division 2 closer to the nonincendive field devices, which reduces the amount of wiring significantly. A Remote I/O station will have I/O cards for nonincendive field wiring and a gateway that merges the information from the I/O cards and sends it via a bus (such as Ethernet IP or, or Profibus DP) to a communication card on the PLC/DCS. Besides reducing wiring and minimizing the space in the safe area, Remote I/O stations also provide preventive diagnostics.

Selection of the I/O cards is simpler as the cards are multifunctional. This means the channels can be independently configured for inputs or outputs and in some cases even from digital to analog.

These solutions which can be installed in Class I, Division 2 could be interconnected to Class 1, Division 2 rated devices such as explosionproof, nonincendive, etc. by following the installation requirements of such instrumentation.

The R. STAHL family of Remote I/O is known as IS1+. Refer to Chapter 6 for product information.

APPLICATION GUIDE

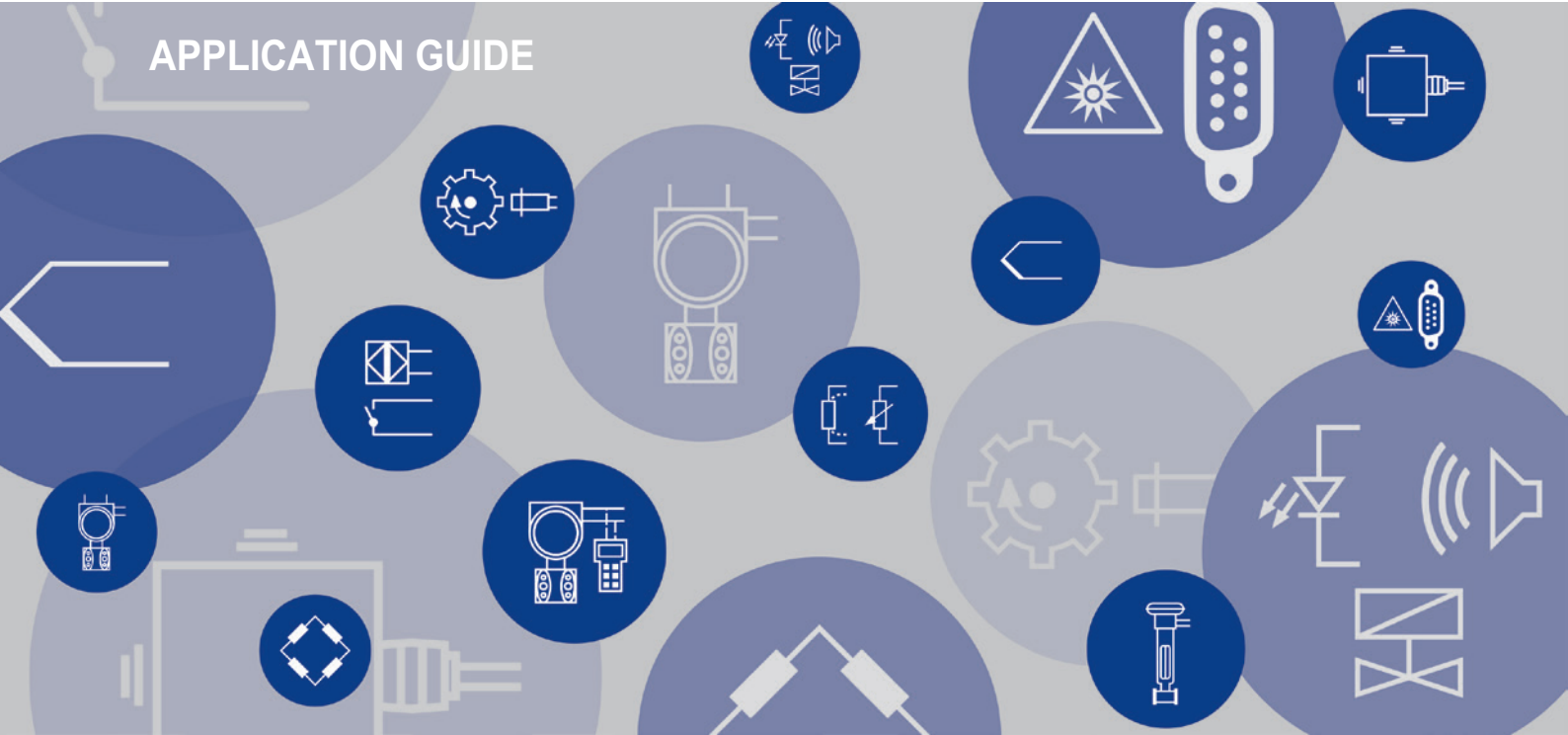

Product	Series	Page	WebCode
Application Guide			
Application Guide		47	

For additional products and information please refer to r-stahl.com

Application Guide

		Application	INTRINSPAK Solution Zener Barrier	ISpac Solution Galvanic Isolator	IS1+ Solution Remote I/O
Analog Input		Transmitter supply (2-wire) 4 ... 20 mA + HART	9002/13-280-093-001 9002/13-280-110-001	9260 9160 9162	9468 9469
		Current source signals 4 ... 20 mA + HART	9002/13-280-093-001 9002/13-280-110-001	9260 9164	9468 9469
Discrete Input		Contact	9002/13-280-110-001	9270 9170 9172/20	9470 9471 9472 9469
		NAMUR proximitors		9270 9170	9470 9471 9472
		PNP, NPN	9002/13-280-100-041 9002/11-280-186-001		9469* 9471* 9472* *only PNP
		Pulse input / NAMUR proximitors		9146	9470 9471 9472
Analog Output		I/P Converter, Control Valve Indicator	9001/01-280-110-101 9002/11-280-186-001	9265 9165 9167	9468 9469
Discrete Output		Solenoid Valves, LEDs Horns, Beacons	9001/01-280-110-101 9002/13-252-121-041 9001/01-252-100-141 9002/11-280-186-001	9275 9276 9175 9176	9475 9470 9471 9472
Temperature Sensors		2-, 3, 4-wire RTD Potentiometers	9002/22-032-300-111 9001/02-016-150-111 9002/77-150-300-001	9282/11 9180 9182	9482
		Thermocouples	9002/77-093-300-001	9282/12 9182	9482
Other Applications		Load cells *For load cell and strain gauge applications, use zener barriers.	16 V Ex. 10 V Ex. ±7.5V Ex.	9002/13-199-225-001 + (2) 9002/11-199-030-001 9002/11-130-360-001 + (2) 9002/11-120-024-001 9002/10-187-270-001 + 9002/10-187-020-001 + 9002/77-093-040-001	
		Accelerometers, Velometers Vibration Sensors		9002/00-260-138-001	9147
		RS485 /RS422 Profibus/Modbus		9002/22-240-160-001 (RS 232 only)	9185 9186

AUTOMATION PORTFOLIO

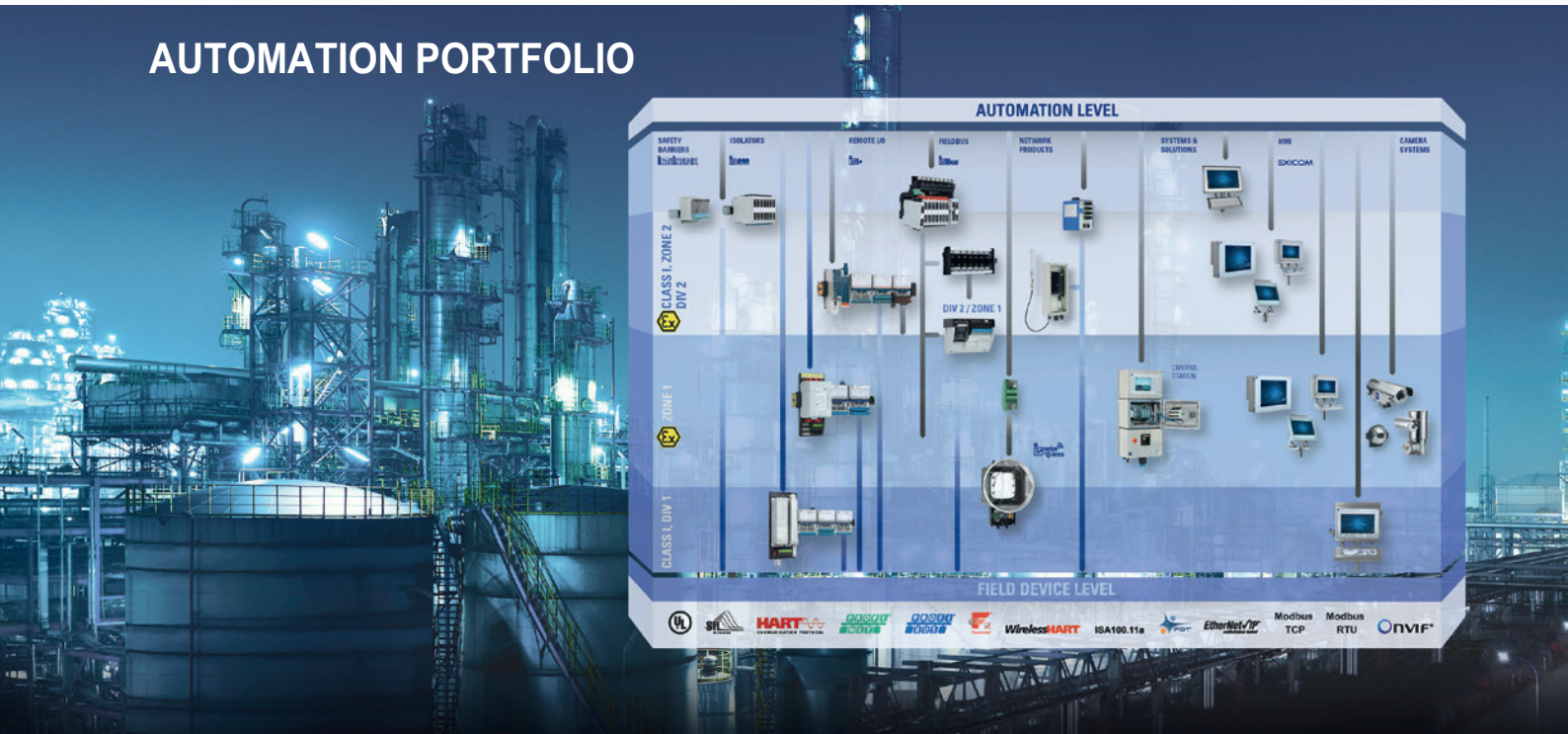

Product	Series	Page	WebCode
Automation Portfolio			
Automation Portfolio		49	

For additional products and information please refer to r-stahl.com

R. STAHL AUTOMATION – MORE THAN YOU EXPECT

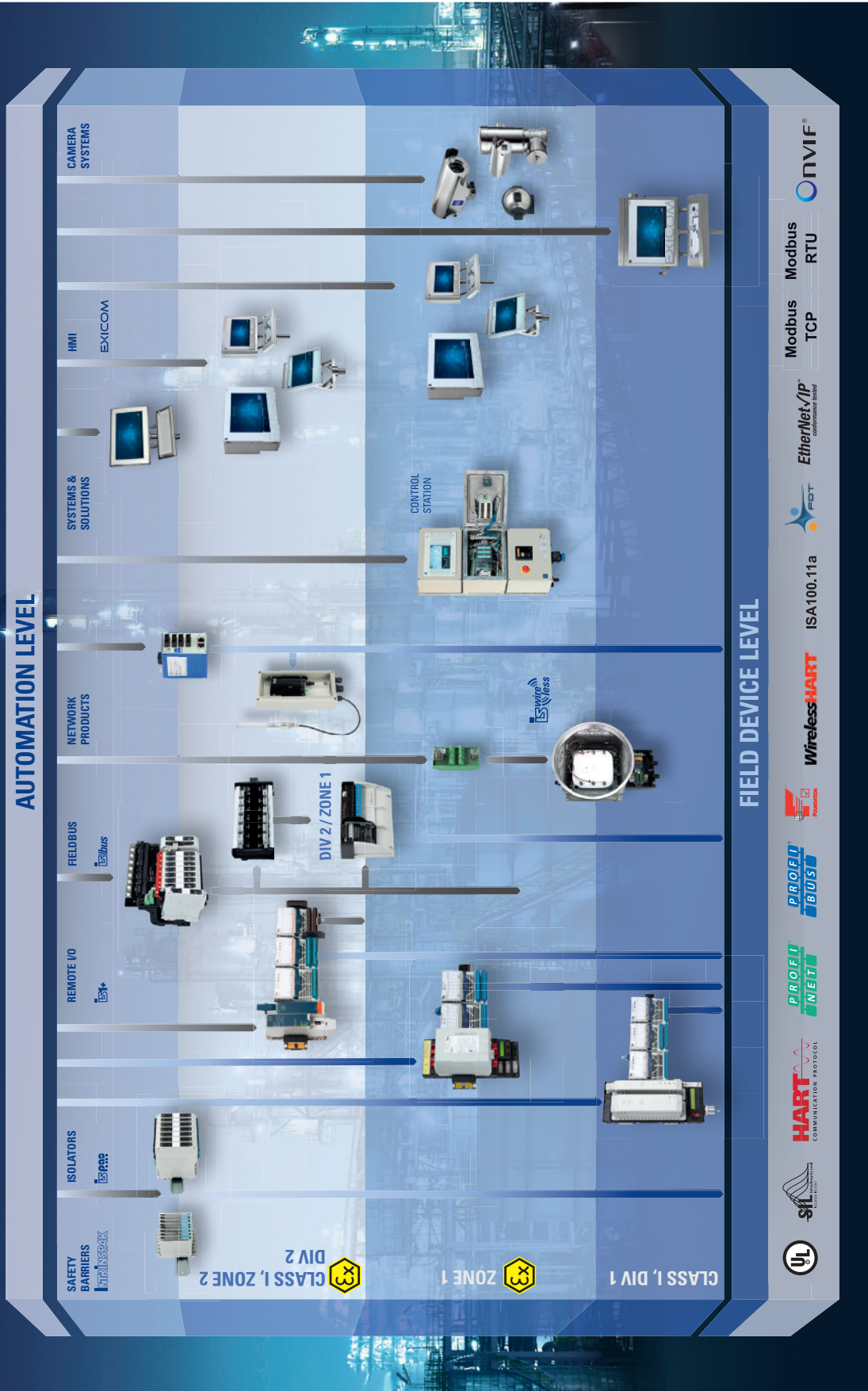



REMOTE I/O – CHAPTER INDEX TABLES

Product	Series	Page	WebCode
Remote I/O – Chapter Index Tables			
Communication & Power Module		51	
Discrete Modules		52	
Pneumatic Output, Analog Modules		53	
Temperature Input Modules		54	
Terminals		55	

For additional products and information please refer to r-stahl.com

Communication & Power Module



Series 9492

Series 9441, 9444

Series 9490

Series 9440

Series 9496

Series 9442, 9445

	Rating	Components			Protocol					Feed		Physical Layer									
		Cl. I, Div. 1	Zone 1	Cl. I, Div. 2 / Zone 2	I/O module	Gateway	Power Supply	Socket	Ethernet IP	ProfINET	Modbus TCP	Redundant Modbus TCP	Profibus DP	Modbus RTU		100 - 250 V AC	24 V DC	FO [pp.is]	RS485-IS	RS-485	Dual CAT 5
Ethernet Protocol	9441/12-00-00	X	X		8	X											X				Page 73
	9444/12-11	X	X				X								X						Page 77
	9492/13-13-41 Socket	X					X	X													Page 73 Page 77
	9492/13-13-31 Socket	X					X		X												
	9492/13-13-11 Socket	X						X			X										
	9492/13-13-12 Socket	X						X			X										
	9492/12-11-11 Socket		X					X			X										
	9492/12-11-31 Socket		X					X		X											
	9492/12-11-41 Socket		X					X	X												
9492/12-11-12 Socket		X					X			X											
9444/12-11 + 9441/12-00-00 modules need the appropriate 9492/1x socket																					
Serial Protocol	9440/22-01-11-C1243	X			8	X	X					X			X			X			Page 60
	9440/22-01-21-C1243	X			8	X	X					X		X			X				
	9440/22-01-11-C1202	X			8	X	X						X		X			X			
	9440/22-01-21-C1202	X			8	X	X						X	X				X			
	9490/12-12-AC/DC Socket	X						X				X	X								
	9490/11-12 Socket		X					X				X	X								
	9490/13-12 Socket		X					X				X	X								
9440/15-01-11-C1198 Socket			X	16	X	X							X	X				X		Page 63	
9440/22 modules need a 9490/1 socket																					
Multi-protocol	9442/35-10-00 CPU			X	16	X												X	X	Page 66	
	9445/35-12 PM			X			X							X						Page 70	
	9496/35-03-00 Socket			X				X	X	X	X	X								Page 66	
	9496/35-04-00 Socket			X				X	X	X	X	X								Page 70	
9442/35-10-00 + 9445/35-12 modules need a 9496/35 socket																					
261232 connector is required for 9445/35																					

Discrete Modules



Series 9470/32



Series 9475/32-04



Series 9475/32-08



Series 9477/12



Series 9470/33



Series 9475/33-08



Series 9477/15



Series 9471



Series 9472

06 a

	 	Rating		Inputs							Outputs							Page			
		Cl. I, Div. 1, Cl. II, Div. 1 / Zone 1	Cl. I, Div. 2, Cl. II, Div. 2 / Zone 2	Channels	I.S. field connections [Ex ia]	Namur & Dry contacts	PNP	Frequency	Active 24 VDC	6 V DC / 2 mA	11.3 V DC / 40 mA	12.3 V DC / 40 mA	12.6 V DC / 30 mA	17.5 V DC / 20 mA	12.3 V DC / 75 mA	24 V DC / 500 mA	Relay for up to 60 V AC		Relay for up to 250 V AC or 110 V DC / 0.3 A	LED per Channel	Plant Stop
Discrete Modules	9470/32-16-11	X		16	X	X	X	X	X									X		Page 89	
	9475/32-04-12	X		4	X					X								X	X	Page 101	
	9475/32-04-22	X		4	X						X							X	X	Page 108	
	9475/32-08-52	X		8	X							X						X	X	Page 115	
	9475/32-08-62	X		8	X								X					X	X	Page 115	
	9477/12-08-12	X		8												X				Page 92	
	9477/12-06-12	X		6													X			Page 112	
	9470/33-16-10		X	16	X	X		X	X	X											Page 105
	9475/33-08-50		X	8	X								X								Page 117
	9475/33-08-60		X	8	X									X							Page 95
	9475/32-04-72		X	4											X				X	X	Page 98
	9477/15-08-12		X	8													X				Page 95
	9471/35-16-11		X	16		X	X	X	X	X					X				X		Page 98
	9472/35-16-12		X	16		X	X	X	X	X					X	X			X	X	Page 98

Pneumatic Output



Series 9478

		Rating		Outputs	Plant Stop	Page
		Cl. I, Div. 1, Cl. II, Div. 1 / Zone 1	Channels	Pneumatic 3/2 way valve. 40-100 psia		
Pneumatic Output	9478/22-08-51	X	8	X	X	Page 120

06 a

Analog Modules



Series 9468



Series 9469

		Rating			I.S. field connections [Ex ia]	Inputs			Outputs		LED per channel	Plant stop	Page
		Cl. I, Div. 1 Cl. II, Div. 1 Zone 1	Cl. I, Div. 2 Cl. II, Div. 2 Zone 2	Channels		2-, 3-, 4-wire 4 ... 20 mA	PNP	Active 24 V DC	2-wire 4 ... 20 mA	24 V DC / 500 mA			
Analog Modules	9468/32-08-11	X		8	X	X			X		X		Page 80
	9468/33-08-10		X	8	X	X			X				Page 83
	9469/35-08-12		X	8		X	X	X	X	X	X	X	Page 86

Temperature Input Modules



Series 9482

06 a

		Rating			I.S. field connections [Ex ia]	Inputs		LED per channel	CJC internal / external	Page
		Cl. I, Div. 1 Cl. II, Div. 1 Zone 1	Cl. I, Div. 2 Cl. II, Div. 2 Zone 2	Channels		TC	RTD			
Temp. Input Modules	9482/32-08-11	X		8	X	X	X	X	X	Page 122
	9482/33-08-11		X	8	X	X	X		X	Page 125

Terminals

Figure	Art. No.	Description	For use with
	162702	Blue terminal block 1...16 screw connections	94xx/32 & 94xx/33
	162718	Blue terminal block 17...32 screw connections	9470 and 9482
	245090	Black terminal block 1...24 spring connections	9469, 9471, 9472
	245091	Black terminal block 25...48 spring connections	9471, 9472
	162704	Black terminal block 1...16 spring	9477
	220101	Partition between I.S. and non I.S. modules	

06 a

REMOTE I/O



Product	Series	Page	WebCode
Analog Modules			
Analog Universal Module HART for Zone 1 / Cl. I, II, Div. 1 - I.S.	9468/32	80	9468A
Analog Universal Module HART for Zone 2 / Cl. I, Div. 2	9469/35	86	9469A
Analog Universal Module HART for Zone 2 / Cl. I, II, Div. 2 - I.S.	9468/33	83	9468B
CPU & Power Modules			
CPU & Power Module for Zone 1 / Cl. I, Div. 1	9440/22	60	9440A
CPU & Power-Module for Zone 2 / Cl. I, II, Div. 2	9440/15	63	9440B
CPU Module for Zone 2 / Cl. I, II, Div. 2	9442/35	66	9442A
Ethernet CPU Module for Zone 1 / Cl. I, Div. 1	9441/12	73	9441A
Ethernet Power Module for Zone 1 / Cl. I, II, Div. 1 - I.S.	9444/12	77	9444A
Power Module for Zone 2 / Cl. I, II, Div. 2	9445/35	70	9445A
Digital Input Output Modules			
Digital Input Output Module 24 V for Zone 2 / Cl. I, Div. 2	9472/35	98	9472A
Digital Input Output Module for Zone 1 / Cl. I, II, Div. 1 - I.S.	9470/32	89	9470C
Digital Input Output Module for Zone 2 / Cl. I, II, Div. 2 - I.S.	9470/33	92	9470D
Digital Input Output Module NAMUR for Zone 2 / Cl. I, Div. 2	9471/35	95	9471B
Digital Output Modules			
Digital Output Module 4-Channel Version for Zone 1, Cl. I, II, Div. 1 - I.S.	9475/32-04	101	9475E
Digital Output Module 4-Channel Version for Zone 1 / Cl. I, II, Div. 2 - I.S.	9475/32-04-72	105	9475F
Digital Output Module 8-Channel Version for Zone 1 / Cl. I, II, Div. 1 - I.S.	9475/33-08	108	9475C
Digital Output Module 8-Channel Version for Zone 2 / Cl. I, II, Div. 2 - I.S.	9475/33-08	112	9475D
Digital Output Module Relay for Zone 1 / Cl. I, Div. 1	9477/12	115	9477A
Digital Output Module Relay for Zone 2 / Cl. I, Div. 2	9477/15	117	9477B
Digital Output Module Valve for Zone 1 / Cl. I, Div. 1	9478	120	9478A
Enclosures for Fieldstations			
IS1+ Remote I/O Standard Enclosure NEC/CEC for Cl. I, Div. I		132	8150O
IS1+ Remote I/O Standard Enclosure NEC/CEC for Cl. I, II, Div. 2 and Cl. I, Zone 2 and Zone 2		135	8150N

Product	Series	Page	WebCode
General			
General		59	
Overview of Functions IS1+		58	
Overview of the System Components		58	
System Components and Accessories			
BusRail	9494	129	9494A
Temperature Input Modules			
Temperature Input Module for Zone 1 / Cl. I, II, Div. 1 - I.S.	9482/32	122	9482A
Temperature Input Module for Zone 2 / Cl. I, II, Div. 2 - I.S.	9482/33	125	9482B

For additional products and information please refer to r-stahl.com

Overview of the System Components

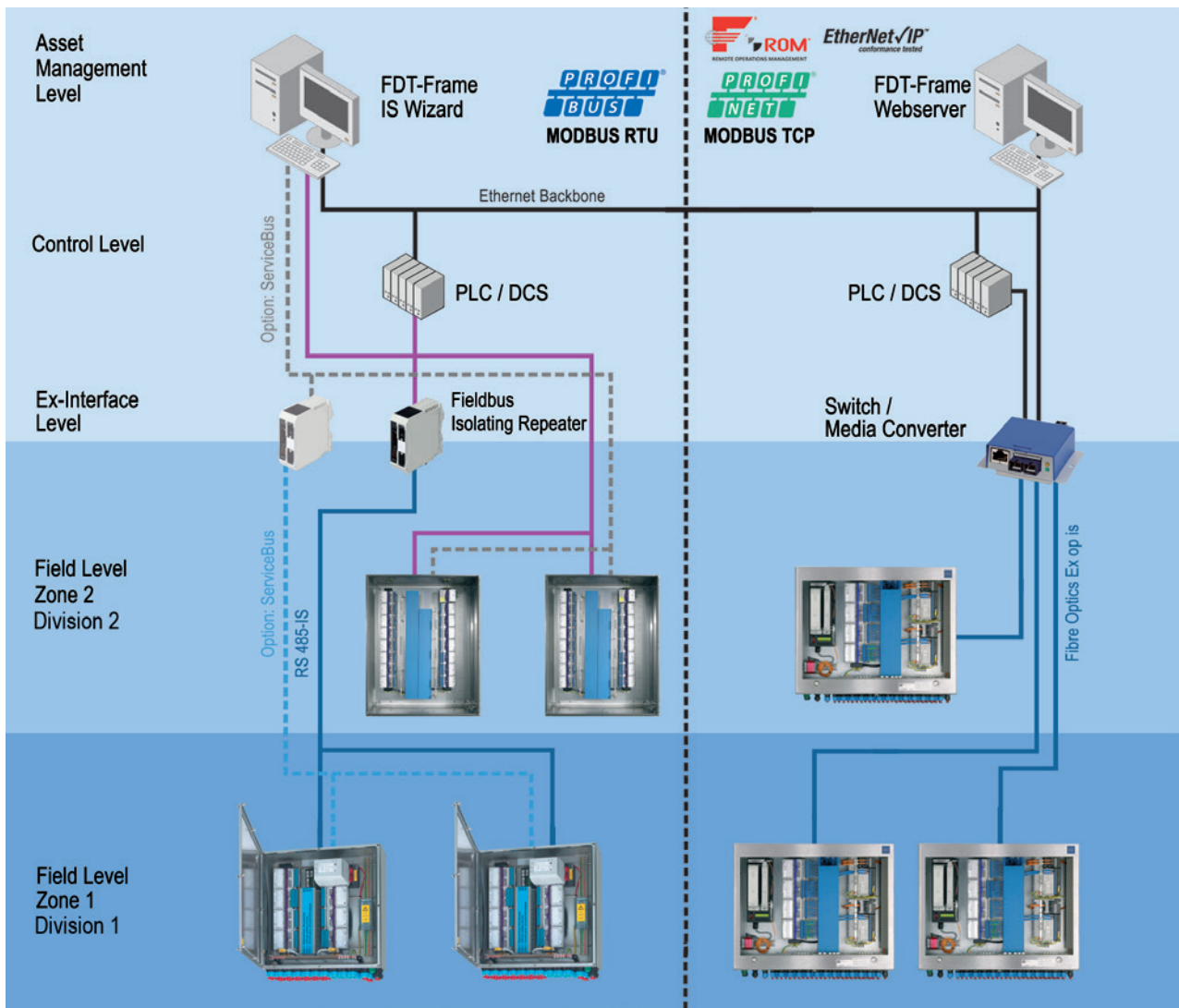

Overview of Functions IS1+

	Installation in Cl. I, Div. 2 / Zone 2	Installation in Cl. I, Div. 1 / Zone 1	RS485-IS	100BASE-TX	LWL ex op is	ServiceBus IS Wizard	ServiceBus DTM	Webserver	COM/Device/ Gateway DTM	HART support	System redundancy
PROFIBUS DP	x	x	x ¹⁾		x	x	x		x	x	x
Modbus RTU	x	x	x ¹⁾		x	x	x		x	x	x
PROFINET	x	x		x	x	x		x		x	x ²⁾
Modbus TCP	x	x		x	x	x		x	x	x	x
EtherNet/IP™	x	x		x	x	x		x	x	x	x ²⁾

¹⁾ when installed in Zone 1 only; in Zone 2: RS485

²⁾ in preparation

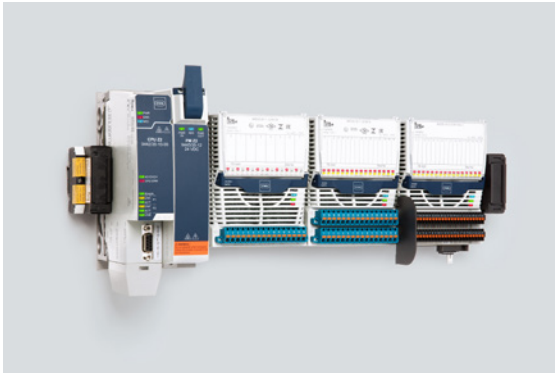

- Inputs and outputs for intrinsically safe (Ex i) and non-intrinsically safe (Ex e/d/q) field devices
- Communication via PROFIBUS DP, Modbus RTU+TCP, PROFINET and EtherNet/IP™
- Hot swap for all modules in Zone 1 and 2, Div. 1 and 2
- System redundancy and media redundancy
- Option ServiceBus for diagnostics and integration into Asset-Management systems
- DTM technology for full access to all system and HART field device information
- Field enclosures in many versions available, freely configurable



IS1+ is exceptionally easy: communication and power modules are installed on a DIN rail together with the different input/output modules. The system's internal, intrinsically safe power supply and data communication is via the bus rail, which is snapped into the DIN rail. The unique power supply concept which was developed specially for hazardous areas makes planning as easy as for normal industrial I/O systems. Plug & Play without separate engineering tools.

IS1+ is particularly flexible: it can be used for small and large signal volumes, intrinsically safe and non-safe signals and installation in hazardous areas of Zone 1 and 2 or Division 1 and 2. Intrinsically safe fieldbuses with copper or fibre optic technology and 100 Mbps Ethernet and various redundancy structures combine the field stations with all conventional automation systems. Modern standard technologies such as completely transparent HART transmission and FDT/DTM are supported throughout.

IS1+ is extremely cost-efficient: modules with up to 16 channels, partly free for parameterization as input or output, ensure a low signal price. Special modules optimised for Zone 2 / Div. 2 installation allow for additional cost reduction. High performance interfaces, e.g. with DTM support, and the integrated diagnostic functions according to NAMUR NE107, allow easy integration of the system into asset management and engineering systems and thus help to significantly reduce costs for operation, troubleshooting and maintenance.

IS1+ is truly universal: the application options are versatile, IS1 can be used effectively in virtually all applications. No matter whether for installation according to IECEx, NEC, CEC or elsewhere in the world, on land, offshore platforms or in shipbuilding - IS1 offers the broadest spectrum of certificates and approvals. A temperature range of -40 to +75 °C is ideal for the most extreme requirements. Add to this, our competence in system solutions with over 30 years of experience for making your solution from universal remote I/O.



- Suitable for Ex i V0/V1 HART PROFIBUS DP, Modbus RTU
- Supporting system redundancy and optical rings
- CPM in Zone 1 and Cl. I, Div. 1 can be hot swapped
- Integration in plant asset management systems via ServiceBus and FDT/DTM
- Integrated Ex i power supply for up to 8 I/O modules

06 b

WebCode 9440A



Modbus RTU



9440/22 series CPU & power modules (CPM) for Zone 1, Cl. I, Div. 1 are used for the intrinsically safe supply of power to up to eight IS1+ I/O modules and to field circuits. Intrinsically safe RS485-IS with PROFIBUS DP or Modbus RTU is used for communicating with the automation system. These CPMs support system and optical rings and can be replaced while the system is in operation (i.e. hot swapped) in Zone 1/Division 1. A DTM and process bus or service bus are used for asset management integration.

	NEC® 500 CEC Appendix J						CEC Section 18						IECEX / ATEX							
	Class I		Class II		Class III		NEC® 505 Class I			NEC® 506			Class I		Class II		Class III			
Division	1	2	1	2	1	2	Zone	0	1	2	20	21	22	Zone	0	1	2	20	21	22
Ex interface	•	•	•	•	•	•	Ex interface		•	•		•	•	Ex interface		•	•		•	•
Installation in	•	•					Installation in		•	•		•	•	Installation in		•	•		•	•

Selection Table					
Installation Zone 1 / Cl. I, Div. 1					
Nominal voltage V _{nom}	Protocols	Redundancy	Product Type	Art. No.	Weight lb
24 V DC	Modbus RTU	full redundancy	9440/22-01-11-C1202	162221	6.53
	Profibus DP V0 Profibus DP V1	full redundancy	9440/22-01-11-C1243	162218 ▲	6.53
	Profibus DP V1 HART	acc. to PNO full redundancy	9440/22-01-11-C1455	203585	6.53
120 V / 230 V AC	Modbus RTU	full redundancy	9440/22-01-21-C1202	162214	6.53
	Profibus DP V0 Profibus DP V1	full redundancy	9440/22-01-21-C1243	162211	6.53
	Profibus DP V1 HART	acc. to PNO full redundancy	9440/22-01-21-C1455	203586	6.53

Please order the 9490 socket (see accessories) separately.

Technical Data		
Variant	24 V DC	120 V / 230 V AC
Explosion Protection		
USA certificate FM	FM17US0332X	FM17US0332X
CAN certificate CSA	1519624	1519624
CAN certificate FM	FM16CA0134X	FM16CA0134X

Technical Data		
Variant	24 V DC	120 V / 230 V AC
Explosion Protection		
USA marking FM	XP; Class I, Div. 1, Groups A,B,C,D; Class I, Zone 1, IIC AIS Cl. I,II,III, Div. 1, Groups A,B,C,D,E,F,G; Class I, Zone 1, [AEx ia, ib] IIC; T4 at Ta = 65 °C; See Doc. 9440 6 031 001 1	XP; Class I, Div. 1, Groups A,B,C,D; Class I, Zone 1, IIC AIS Cl. I,II,III, Div. 1, Groups A,B,C,D,E,F,G; Class I, Zone 1, [AEx ia, ib] IIC; T4 at Ta = 65 °C; See Doc. 9440 6 031 001 1
CAN marking CSA	Class I, Zone 1, Ex e d ib [ia/ib] IIC, T4	Class I, Zone 1, Ex e d ib [ia/ib] IIC, T4
CAN marking FM	XP; Class I, Div. 1, Groups A,B,C,D; Class I, Zone 1 per CEC 18-100 AIS Cl. I,II,III, Div. 1, Groups A,B,C,D,E,F,G; Class I, Zone 1, [Ex ia, ib] IIC; T4 at Ta = 65 °C; See Doc. 9440 6 031 001 1	XP; Class I, Div. 1, Groups A,B,C,D; Class I, Zone 1 per CEC 18-100 AIS Cl. I,II,III, Div. 1, Groups A,B,C,D,E,F,G; Class I, Zone 1, [Ex ia, ib] IIC; T4 at Ta = 65 °C; See Doc. 9440 6 031 001 1
IECEX gas explosion protection	Ex d [ia] [ib] IIC T4 Gb	Ex d [ia] [ib] IIC T4 Gb
Certificates	ATEX (DEK), Brazil (ULB), Canada (CSA), Canada (FM), EAC (STV), IECEX (DEK), Korea (KTL), USA (FM)	ATEX (DEK), Brazil (ULB), Canada (CSA), Canada (FM), EAC (STV), IECEX (DEK), Korea (KTL), USA (FM)
Ship approval	ABS, CCS, ClassNK, DNV GL, RINA	ABS, CCS, ClassNK, DNV GL, RINA
Electrical Data		
Transmission distance/rate for copper RS485	1200 m at 9.6...93,75 kbit/s 1000 m at 187.5 kbit/s 400 m at 500 kbit/s 200 m at 1.5 Mbit/s	1200 m at 9.6...93,75 kbit/s 1000 m at 187.5 kbit/s 400 m at 500 kbit/s 200 m at 1.5 Mbit/s
Connection Fieldbus RS485	Sub-D socket 9-pole	Sub-D socket 9-pole
Connection ServiceBus RS485	Sub-D socket 9-pole	Sub-D socket 9-pole
Auxiliary Power		
Auxiliary power voltage range	20 ... 35 V DC	90 ... 253 V AC
Current consumption (without I/O modules)	0.21 A at 24 V DC	Approx. 25 mA at 230 V AC Approx. 48 mA at 120 V AC
Current consumption (with 8 I/O modules)	Approx. 2.5 A at 24 V DC	Approx. 0.4 A at 230 V AC Approx. 0.8 A at 120 V AC
Power dissipation (without I/O modules)	5 W	8.4 W
Power dissipation (per I/O module)	1.4 W	1 W
Ambient Conditions		
Ambient temperature °F	-4°F ... +149°F	-4°F ... +149°F
Ambient temperature °C	-20°C ... +65°C	-20°C ... +65°C
Mechanical Data		
Degree of protection IP (IEC 60529)	IP20 connections IP30 modules	IP20 connections IP30 modules
Width inches	3.78 in	3.78 in
Width	96.5 mm	96.5 mm
Mounting depth inches	6.69 in	6.69 in
Depth	170 mm	170 mm
Length inches	9.96 in	9.96 in
Length	253 mm	253 mm

Accessories				
Figure	Description	Product Type	Art. No.	Weight lb
	Cable type: BUS 4000-C-PE 2x0,64mm 02YS(St) CY2Y Color (sheath): black Application area: Outdoor Installation outdoors and directly in the ground, UV-resistant	O2Y(ST)CY2Y	105444	0.66
	Cable type: 02YS(St) CHSH Color (sheath): blue Application area: Offshore Halogen-free, steel wire braid armored cable	02YS(ST)CHSH Profibus	105400	-

06 b

Accessories				
Figure	Description	Product Type	Art. No.	Weight lb
Cable for PROFIBUS DP, RS485-IS				
	<p>Cable type: BUS 4000-C-PVC 2x0,64mm 02Y(S) CY</p> <p>Color (sheath): blue</p> <p>Application area: Indoor</p> <p>Standard type for indoor installation</p>	02Y(ST)CY	105437	-
Series 9490/11 - Socket for CPU and Power Module				
	<p>Zone 1 connection by means of Ex e terminals</p> <p>24 V DC, 120 / 230 V AC</p>	9490/11-12	162707 ▲	1.06
Series 9490/13 - Socket for CPU and Power Module				
	<p>Zone 1, connection via pig tail</p> <p>24 V DC, 120 / 230 V AC</p>	9490/13-12	162711	1.98
Series 9490/12 - Socket for CPU and Power Module				
	<p>Division 1, connection via conduit</p> <p>24 V DC, 120 / 230 V AC</p> <p>9491/00-13-70 conduit hub is required and needs to be ordered separately</p>	9490/12-12	162715	1.98
SUB-D socket				
	<p>9-pin for connection of the fieldbus or ServiceBus to the CPU & power module Series 9440/22 and fieldbus-isolating repeater 9185.</p> <p>Integrated terminator can be switched on or off.</p> <p>For RS 485 IS to PNO standard.</p>	-	162693 ▲	0.22
Optical Fieldbus Isolating Repeater, Zone 2 / Div. 2				
	<p>Isolating repeater for installation in Zone 2 / Div. 2</p> <p>For fieldbus via fibre optic intrinsically safe cables "ex op is" into Zone 1 / Div. 1</p> <p>Optical ring possible</p> <p>Extensive diagnostic function and fault-contact</p> <p>Suitable for Profibus DP up to 1.5 MBit/s</p> <p>Further versions and information see data sheet of Series 9186 optical fieldbus-isolating repeater</p>	9186/15-12-11	160624 ▲	0.54
Fieldbus Isolating Repeater Series 9185/11				
	<p>Equipment for installation in safe areas or Zone 2/Div. 2</p> <p>For fieldbuses with RS-485-IS-interface - Zone 1 / Class I, II, III Division 1 and Class I, II, III Zone 1</p> <p>Suitable for PROFIBUS DP, Modbus, R. STAHL service bus</p> <p>RS-232, RS-422, RS-485 interface with the automation system</p> <p>Transmission rate automatically set with PROFIBUS DP</p> <p>Adjustable transmission rate (1.2 kBit/s to 1.5 MBit/s)</p> <p>24 V AC/DC auxiliary power</p> <p>For further information, see data sheet for 9185/11</p>	9185/11-35-10s	227598 ▲	0.77
Device DTM IS1+ for PROFIBUS DP and Ethernet				
	<p>Parameterization and configuration of the IS1+ system</p> <p>Communicating with HART-compatible field devices</p> <p>Supports all common FDT frame applications (e.g. FieldCare, PactWare™)</p> <p>Condition Monitoring</p> <p>Scan function for automatic topology generation</p> <p>Download at r-stahl.com</p>	-	-	-
IS1 PCS7 APL field device library				
	<p>Easy connection of IS1+ modules to the SIEMENS control system PCS7 via PROFIBUS DP.</p> <p>The library contains CFC driver modules created in conformance with PCS7 modules, and documentation in English.</p> <p>HOTLINE support inclusive.</p> <p>Order, processing and support are carried out directly via SIEMENS: function.blocks.industry@siemens.com</p> <p>Hardware/software requirements: SIEMENS PCS7 V7.1 to 8 SP2 and IS1+ CPM 9440/...C1455 from V03.45 and GSD from V03.05</p>	-	-	-

Dimensional drawings on the Internet r-stahl.com



- Suitable for Modbus RTU
- Supporting system redundancy and optical rings
- Integration in plant asset management systems via ServiceBus and FDT/DTM

WebCode **9440B**



Modbus RTU

06 b

9440/15 series CPU & power modules (CPM) for Zone 2, Cl. I, II, Div 2 are used for the intrinsically safe supply of power to up to 16 IS1+ I/O modules and to field circuits. RS485 with Modbus RTU is used for communicating with the automation system. The CPMs support system redundancy and optical rings. A DTM and process bus or service bus are used for asset management integration.

	NEC® 500 CEC Appendix J						CEC Section 18 NEC® 505 NEC® 506						IECEX / ATEX						
	Class I		Class II		Class III		Class I			Class I			0		20		21		22
Division	1	2	1	2	1	2	0	1	2	20	21	22	0	1	2	20	21	22	
Ex interface		•		•		•			•		•	•			•		•	•	
Installation in		•		•		•			•		•	•			•		•	•	

Selection Table				
Installation	Zone 2 / Cl. I, II, Div. 2			
Protocols	Redundancy	Product Type	Art. No.	Weight lb
Modbus RTU	full redundancy	9440/15-01-11-C1198	162188	1.34

Technical Data	
Explosion Protection	
USA certificate FM	FM17US0332X
CAN certificate CSA	1519624
CAN certificate FM	FM16CA0134X
USA marking FM	NI; Class I, Div. 2, Groups A,B,C,D; Cl. I, Zone 2, IIC; ANI; Class I,II,III, Div. 2, Class A,B,C,D,E,F,G; Class I, Zone 2, IIC; T4 at Ta = 65 °C; See Doc. 9440 6 031 002 1
CAN marking CSA	Class I, Zone 2, Ex nA [ja/ib] IIC, T4
CAN marking FM	NI; Class I, Div. 2, Groups A,B,C,D; Class I, Zone 2 per CEC 18-150 ANI; Class I,II,III, Div. 2, Groups A,B,C,D,E,F,G; T4 at Ta = 65 °C; See Doc. 9440 6 031 002 1
IECEX gas explosion protection	Ex nA [ja, ib Gb] IIC T4 Gc
Certificates	ATEX (PTB), Brazil (ULB), Canada (CSA), Canada (FM), EAC (STV), IECEX (PTB), Korea (KTL), USA (FM)
Ship approval	ABS, CCS, ClassNK, DNV GL, RINA

Technical Data

Electrical Data

Transmission distance/rate for copper RS485	1200 m at 9.6...93.75 kbit/s 1000 m at 187.5 kbit/s 400 m at 500 kbit/s 200 m at 1.5 Mbit/s
---	--

Connection Fieldbus RS485	Sub-D socket 9-pole
---------------------------	---------------------

Connection ServiceBus RS485	Sub-D socket 9-pole
-----------------------------	---------------------

Auxiliary Power

Auxiliary power voltage range	20 ... 35 V DC
-------------------------------	----------------

Current consumption (without I/O modules)	0.3 A (24 V DC)
---	-----------------

Current consumption (with 8 I/O modules)	Approx. 2.5 A at 24 V DC
--	--------------------------

Current consumption (with 16 I/O modules)	Approx. 4.9 A at 24 V DC
---	--------------------------

Power dissipation (without I/O modules)	7.2 W
---	-------

Power dissipation (per I/O module)	1 W
------------------------------------	-----

Ambient Conditions

Ambient temperature °F	-4°F ... +149°F
------------------------	-----------------

Ambient temperature °C	-20°C ... +65°C
------------------------	-----------------

Mechanical Data

Degree of protection IP (IEC 60529)	IP20 connections IP30 modules
-------------------------------------	----------------------------------

Width inches	3.78 in
--------------	---------

Width	96.5 mm
-------	---------





Mounting depth inches	4.21 in
-----------------------	---------



Depth	107 mm
-------	--------

Length inches	5.83 in
---------------	---------

Length	148 mm
--------	--------

Accessories

Figure	Description	Product Type	Art. No.	Weight lb
Cable for PROFIBUS DP, RS 485, RS485-IS				
	Cable type: BUS 4000-C-PE 2x0,64mm 02YS(St) CY2Y Color (sheath): black Application area: Outdoor Installation outdoors and directly in the ground, UV-resistant	O2Y(ST)CY2Y	105444	0.66
Cable for PROFIBUS DP, RS485				
	Cable type: 02YS(St) CHSH Color (sheath): violet Application area: Offshore Halogen-free, steel wire braid armored cable	02YS(ST)CHSH ProfibusDP	209430	-
	Cable type: BUS 4000-C-PVC 2x0,64mm 02YS(St) CY Color (sheath): violet Application area: Indoor Standard type for indoor installation	O2Y(ST)CY	105438	0.66
Sub-D plug + PG interface				
	9-pin for connection of the fieldbus or ServiceBus to the CPU & power module Series 9440/15 and fieldbus-isolating repeater 9185. Integrated terminator can be switched on or off. For non-intrinsically safe RS-485.	-	105715 ▲	-
Fieldbus Isolating Repeater Series 9185/12				
	Equipment for installation in safe areas or Zone 2 / Div. 2 For fieldbuses with RS-485 interface. Suitable for PROFIBUS DP, Modbus. R. STAHL service bus. RS-232, RS-422, RS-485 interface with the automation system Transmission rate automatically set with PROFIBUS DP Adjustable transmission rate (1.2 kbit/s to 1.5 Mbit/s) 24 V AC/DC auxiliary power For further information, see data sheet for 9185/12 series	9185/12-45-10s	227600 ▲	0.77

Accessories				
Figure	Description	Product Type	Art. No.	Weight lb
Optical Fieldbus Isolating Repeater, Zone 2 / Div. 2				
	Isolating repeater for installation in Zone 2 / Div. 2 For fieldbus via fibre optic intrinsically safe cables "ex op is" into Zone 1 / Div. 1 Optical ring possible Extensive diagnostic function and fault-contact Suitable for Profibus DP up to 1.5 MBit/s Further versions and information see data sheet of Series 9186 optical fieldbus-isolating repeater	9186/15-12-11	160624 ▲	0.54
Device DTM IS1+ for PROFIBUS DP and Ethernet				
	Parameterization and configuration of the IS1+ system Communicating with HART-compatible field devices Supports all common FDT frame applications (e.g. FieldCare, PactWare™) Condition Monitoring Scan function for automatic topology generation Download at r-stahl.com	-	-	-
IS1 PCS7 APL field device library				
	Easy connection of IS1+ modules to the SIEMENS control system PCS7 via PROFIBUS DP. The library contains CFC driver modules created in conformance with PCS7 modules, and documentation in English. HOTLINE support inclusive. Order, processing and support are carried out directly via SIEMENS: function.blocks.industry@siemens.com Hardware/software requirements: SIEMENS PCS7 V7.1 to 8 SP2 and IS1+ CPM 9440/...C1455 from V03.45 and GSD from V03.05	-	-	-
Dimensional drawings on the Internet r-stahl.com				

06 b



- Support for PROFIBUS DP, PROFINET, Modbus TCP and EtherNet/IP™; incl. HART transmission
- RS485 interfaces (max. 12 Mbit/s) and Ethernet (max. 100 Mbit/s)
- Comprehensive diagnostics based on NE 107
- Support of FDT/DTM and web server for integration in asset management systems
- Enhanced ambient temperature range from -40 °C to +75 °C

06 b

WebCode 9442A



Modbus TCP

EtherNet/IP



The 9442/35 CPU module functions as a gateway between the IS1+ Remote I/O system and the automation system. All supported communication protocols are in the CPU module and can be configured by the user. In addition to the process values, other information such as diagnostics, parameterisation and configuration is transmitted over the CPU module. Communication with the I/O modules is implemented via the 9496 socket and the 9494 BusRail. Integration in control systems and plant asset management tools is implemented using standards such as GSD, EDS, web servers and FDT/DTM.

	NEC® 500 CEC Appendix J					
	Class I		Class II		Class III	
Division	1	2	1	2	1	2
Ex interface		•		•		•
Installation in		•				

	CEC Section 18					
	NEC® 505 Class I			NEC® 506		
Zone	0	1	2	20	21	22
Ex interface			•			
Installation in			•			

	IECEX / ATEX					
	Zone	0	1	2	20	21
Ex interface			•			
Installation in			•			

Selection Table

Installation	Zone 2 / Cl. I, II, Div. 2	
Product Type		Art. No.
9442/35-10-00		246854 ▲

Please order the 9445/35 power module and 9496/35 base (see accessories) separately.





Technical Data

Explosion Protection	
USA certificate FM	FM17US0332X
CAN certificate FM	FM16CA0134X
USA marking FM	NI; Class I, Div. 2, Groups A,B,C,D; Class I, Zone 2, AEx ec ia [ia Ga] IIC T4 Gc; Ta = -40°C ... +75°C; See Doc. 9442 6 031 002 1
CAN marking FM	NI; Class I, Div. 2, Groups A,B,C,D; Class I, Zone 2, Ex ec ia [ia Ga] IIC T4 Gc; Ta = -40°C ... +75°C; See Doc. 9442 6 031 002 1
IECEX gas explosion protection	Ex ec ia [ia Ga] IIC T4 Gc
Certificates	ATEX (PTB), Canada (FM), EAC (Sertium), IECEX (PTB), USA (FM)
Electrical Data	
Connection RS485 Interface	Sub-D plug, 9-pole

Technical Data	
Electrical Data	
Transmission distance/rate for copper RS485	1200 m at 9.6...93,75 kbit/s 1000 m at 187.5 kbit/s 400 m at 500 kbit/s 200 m at 1.5 Mbit/s 100 m at 12 Mbit/s
Transmission distance/rate FO RS485	approx. 2000 m at 1,5 Mbit/s
Connection Ethernet Interface	2x RJ45 connector
Auxiliary Power	
Current consumption max.	0.3 A
Power supply	via socket 9496 a. PM 9445/35
Power dissipation max.	5 W
Ambient Conditions	
Ambient temperature °F	-40°F ... +149°F (without mounting plate) -40°F ... +158°F with 3 mm mounting plate sheet steel) -40°F ... +167°F (with 6 mm mounting plate aluminium)
Ambient temperature °C	-40°C ... +65°C (without mounting plate) -40°C ... +70°C with 3 mm mounting plate sheet steel) -40°C ... +75°C (with 6 mm mounting plate aluminium)
Storage temperature °F	-40°F ... +176°F
Storage temperature °C	-40°C ... +80°C
Mechanical Data	
Degree of protection IP (IEC 60529)	IP30

Accessories				
Figure	Description	Product Type	Art. No.	Weight lb
Series 9496/35 - Socket for CPU & Power Module				
	Zone 2 / Div. 2 simplex, 3 slots for mounting / installing 1 x CPU and 2 x power module or 2 x CPU und 1 x power module Dimensions: approx. L = 167 mm, W = 96 mm, H = 50.6 mm	9496/35-03-00	246871 ▲	0.88
	Zone 2 / Div. 2 redundant, 4 slots for mounting / installing 2 x CPU and 2 x power module Dimensions: approx. L = 167 mm, W = 152 mm, H = 50.6 mm	9496/35-04-00	262392	1.32
Fieldbus Isolating Repeater Series 9185/12				
	Equipment for installation in safe areas or Zone 2 / Div. 2 For fieldbuses with RS-485 interface. Suitable for PROFIBUS DP, Modbus, R. STAHL service bus. RS-232, RS-422, RS-485 interface with the automation system Transmission rate automatically set with PROFIBUS DP Adjustable transmission rate (1.2 kbit/s to 1.5 Mbit/s) 24 V AC/DC auxiliary power For further information, see data sheet for 9185/12 series	9185/12-45-10s	227600 ▲	0.77
Optical Fieldbus Isolating Repeater, Zone 2 / Div. 2				
	Isolating repeater for installation in Zone 2 / Div. 2 For fieldbus via fibre optic intrinsically safe cables "ex op is" into Zone 1 / Div. 1 Optical ring possible Extensive diagnostic function and fault-contact Suitable for Profibus DP up to 1.5 MBit/s Further versions and information see data sheet of Series 9186 optical fieldbus-isolating repeater	9186/15-12-11	160624 ▲	0.54
Media converter FX op is / TX SC for Cl. I, Div. 2 and Zone 2				
	Media Converter of 10/100 Base-Tx (1 x RJ45 port) to 100 Base-Fx "Ex op is" (1 x FO port SC); Multi mode (up to 4 km range); Webcode: 9721A	9721/13-11-14	220381 ▲	0.53

06 b

Accessories				
Figure	Description	Product Type	Art. No.	Weight lb
Unmanaged Switch FX op is / TX SC				
	Unmanaged Switch FX op is to TX; SC plug connector FO cable 4 multi mode (MM), 2 RJ45, Installation in Zone 2	9721/13-42-14	243427 ▲	1.1
Device DTM IS1+ for PROFIBUS DP and Ethernet				
	Parameterization and configuration of the IS1+ system Communicating with HART-compatible field devices Supports all common FDT frame applications (e.g. FieldCare, PactWare™) Condition Monitoring Scan function for automatic topology generation Download at r-stahl.com	-	-	-
IS1 PCS7 APL field device library				
	Easy connection of IS1+ modules to the SIEMENS control system PCS7 via PROFIBUS DP. The library contains CFC driver modules created in conformance with PCS7 modules, and documentation in English. HOTLINE support inclusive. Order, processing and support are carried out directly via SIEMENS: function.blocks.industry@siemens.com Hardware/software requirements: SIEMENS PCS7 V7.1 to 8 SP2 and IS1+ CPM 9440/...C1455 from V03.45 and GSD from V03.05	-	-	-
USB Converter				
	USB RS485 converter for installation in Zone 2. Noise insensitive, bidirectional conversion of USB data to RS485 serial data with power supply via USB port. Can be used for various applications, e.g. for missing RS485 interfaces to PCs. For further information, see data sheet for Series 9787 - Webcode 9787A	9787/15-11-11	266011	0.37
USB Cable				
	Cable type: USB 2 5-pole with shielding Connector plug: USB type A / USB type A Temperature range: -40 °C ... +85 °C Cable colour: black Length: 2,5 m	-	268119	-

Dimensional Drawings (All Dimensions in mm [inches]) – Subject to Alterations

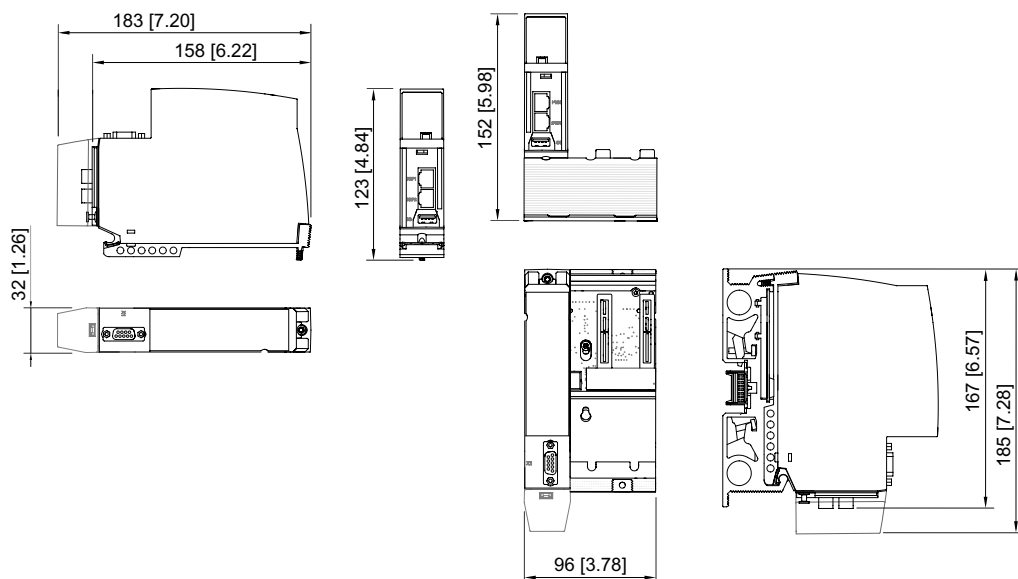

CPU Module

Series 9442/35 for Zone 2 / Cl. I, II, Div. 2

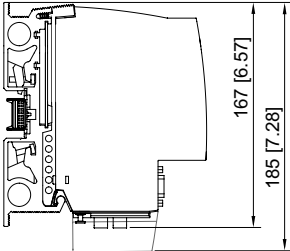
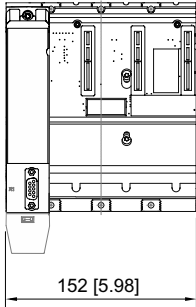
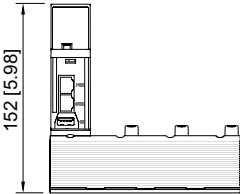

06 b



- 24 V DC supply module for IS1+ CPU modules and 16 I/O modules
- Redundancy of the power module with load sharing possible
- Integrated polarity reversal protection
- Error messages in accordance with NE 107 (overload, excess temperature, maintenance requirements)
- Support of FDT/DTM and Webserver for integration in asset management systems
- Extended ambient temperature range -40 °C to +75 °C

06 b

WebCode 9445A



The 9445/35 power module is used for intrinsically safe power supply to the 9442/35 CPU and up to 16 I/O modules. The auxiliary power connection is established using an extendable terminal with unconnected cable end (accessories). Up to two 9445/35 power modules can be connected to a 9496/35 base to provide a redundant power supply for the 9442/35 CPU and the I/O modules. The 9445/35 power module monitors itself and reports notifications to the control system and asset management systems when there is an overload, the ambient temperatures are too high or the end of the service life has been reached

	NEC® 500 CEC Appendix J					
	Class I		Class II		Class III	
Division	1	2	1	2	1	2
Ex interface		•		•		•
Installation in		•				

	CEC Section 18					
	NEC® 505 Class I			NEC® 506		
Zone	0	1	2	20	21	22
Ex interface			•			
Installation in			•			

	IECEX / ATEX					
	Zone	0	1	2	20	21
Ex interface			•			
Installation in			•			

Selection Table

Installation	Zone 2 / Cl. I, II, Div. 2		
Auxiliary power nominal voltage	Product Type	Art. No.	
24 V DC	9445/35-12	257290 ▲	

Please order the 9442/35 CPU, 9496/35 base and 24 V auxiliary power set (see accessories) separately.

Technical Data

Explosion Protection	
USA certificate FM	FM17US0332X
CAN certificate FM	FM16CA0134X
USA marking FM	NI; Class I, Div. 2, Groups A,B,C,D; Class I, Zone 2, AEx ec [ia Ga, ib Gb] IIC T4 Gc; Ta = -40°C ... +75°C; See Doc. 9442 6 031 002 1
CAN marking FM	NI; Class I, Div. 2, Groups A,B,C,D; Class I, Zone 2, Ex ec [ia Ga, ib Gb] IIC T4 Gc; Ta = -40°C ... +75°C; See Doc. 9442 6 031 002 1
IECEX gas explosion protection	Ex ec [ia Ga, ib Gb] IIC T4 Gc
Certificates	ATEX (PTB), Canada (FM), EAC (Sertium), IECEX (PTB), USA (FM)
Auxiliary Power	
Auxiliary power voltage range	19 ... 32 V DC
Polarity reversal protection	Yes
Auxiliary power	Connection: 2-pole via a pluggable terminal with a 3 m single core

Technical Data	
Auxiliary Power	
Redundancy	Yes (by using two power modules)
Ambient Conditions	
Ambient temperature °F	-40°F ... +149°F (without mounting plate) -40°F ... +158°F with 3 mm mounting plate sheet steel -40°F ... +167°F (with 6 mm mounting plate aluminium)
Ambient temperature °C	-40°C ... +65°C (without mounting plate) -40°C ... +70°C with 3 mm mounting plate sheet steel -40°C ... +75°C (with 6 mm mounting plate aluminium)
Storage temperature °F	-40°F ... +176°F
Storage temperature °C	-40°C ... +80°C
Mechanical Data	
Degree of protection IP (IEC 60529)	IP30

06 b

Accessories				
Figure	Description	Product Type	Art. No.	Weight lb
Connection set				
	Power supply set 24 V (3 m)	-	261232 ▲	0.22
Series 9496/35 - Socket for CPU & Power Module				
	Zone 2 / Div. 2 simplex, 3 slots for mounting / installing 1 x CPU and 2 x power module or 2 x CPU und 1 x power module Dimensions: approx. L = 167 mm, W = 96 mm, H = 50.6 mm	9496/35-03-00	246871 ▲	0.88
	Zone 2 / Div. 2 redundant, 4 slots for mounting / installing 2 x CPU and 2 x power module Dimensions: approx. L = 167 mm, W = 152 mm, H = 50.6 mm	9496/35-04-00	262392	1.32

Dimensional Drawings (All Dimensions in mm [inches]) – Subject to Alterations

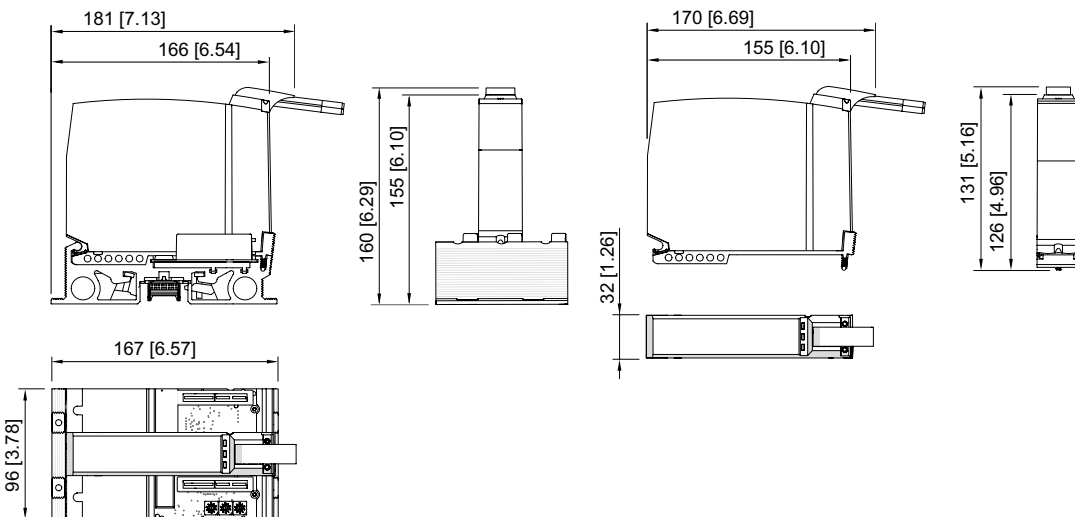

06 b

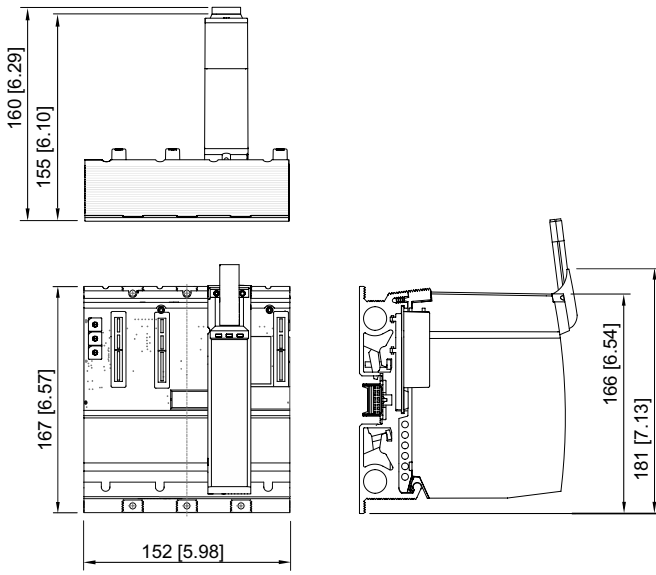



- Suitable for “op is” 100 Mbit/s Ethernet with PROFINET, Modbus TCP or Ethernet/IP™
- Redundant activation with Modbus TCP possible
- CPU can be hot swapped in Zone 1 and Cl. I, Div. 1

WebCode 9441A



Modbus TCP



EtherNet/IP



06 b

The 9441/12 series CPU for Zone 1, Cl. I, Div. 1 is used to communicate with the automation system via PROFINET, Modbus TCP or Ethernet/IP™. The connection is established by means of an optically inherently safe “op is” fibre optic, which can be connected and disconnected in hazardous areas.

IS1+ and connected HART devices are integrated into asset management systems using a DTM.

	NEC® 500 CEC Appendix J					
	Class I		Class II		Class III	
Division	1	2	1	2	1	2
Ex interface	•	•	•	•	•	•
Installation in	•	•				

	CEC Section 18					
	NEC® 505			NEC® 506		
	Class I					
Zone	0	1	2	20	21	22
Ex interface		•	•		•	•
Installation in		•	•			•

	IECEx / ATEX					
Zone	0	1	2	20	21	22
Ex interface		•	•		•	•
Installation in		•	•		•	•

Selection Table				
Installation	Zone 1 / Cl. I, Div. 1			
Protocols	Product Type	Art. No.	Weight lb	
EtherNet/IP Modbus TCP PROFINET	9441/12-00-00	211045 ▲	2.87	
Please order the 9444/12 power module and 9492/12; 9492/13 base (see accessories) separately.				





Technical Data	
Explosion Protection	
USA certificate FM	FM17US0332X
CAN certificate FM	FM16CA0134X
USA marking FM	XP; Class I, Div. 1, Groups A,B,C,D; Class I, Zone 1, IIC AIS Class I,II,III, Div. 1, Groups A,B,C,D,E,F,G; Class I, Zone 0, [AEx ia] IIC; T4 at Ta = 65 °C; See Doc. 9441 6 031 001 1
CAN marking FM	XP; Class I, Div. 1, Groups A,B,C,D; Class I, Zone 1 per CEC 18-100 AIS Class I,II,III, Div. 1, Groups A,B,C,D,E,F,G; Class I, Zone 0, [Ex ia] IIC; T4 at Ta = 65 °C; See Doc. 9441 6 031 001 1
IECEx gas explosion protection	Ex d [ia Ga] [op is T6 Ga] IIC T4 Gb
IECEx dust explosion protection	[Ex ia Da] [Ex op is Da] IIIC
Certificates	ATEX (DEK), Brazil (ULB), Canada (FM), EAC (STV), IECEx (DEK), International (FF), USA (FM)
Ship approval	ABS, CCS, ClassNK, DNV GL, RINA

Technical Data

Electrical Data	
Interface Ethernet	Fibre optic cable, 100BASE-FX, Ex op is (IEC 60079-28)
Transmission distance	2000 m
Transmission rate	max. 100 Mbit/s
Ethernet Connection	Multimode 62,5/125 µm (OM1) and 50/125 µm (OM3, OM4), plug LC
Auxiliary Power	
Nominal voltage V_{nom}	24 V DC
Current consumption (without I/O modules)	0.36 A at 24 V DC
Current consumption (with 8 I/O modules)	Approx. 2.6 A at 24 V DC
Current consumption (with 16 I/O modules)	Approx. 4.9 A at 24 V DC
Power dissipation (without I/O modules)	8.6 W
Power dissipation (8 I/O modules)	14 W
Ambient Conditions	
Ambient temperature °F	-4°F ... +149°F
Ambient temperature °C	-20°C ... +65°C
Mechanical Data	
Degree of protection IP (IEC 60529)	IP30

Accessories

Figure	Description	Product Type	Art. No.	Weight lb
Device DTM IS1+ for PROFIBUS DP and Ethernet				
	Parameterization and configuration of the IS1+ system Communicating with HART-compatible field devices Supports all common FDT frame applications (e.g. FieldCare, PactWare™) Condition Monitoring Scan function for automatic topology generation Download at r-stahl.com	-	-	-
Series 9492/13 - Socket for CPU and Power Module				
	Division 1 Fieldbus: Modbus TCP, simplex 24 V DC	9492/13-13-11	202098	3.09
	Division 1 Fieldbus: Modbus TCP, redundant 24 V DC	9492/13-13-12	202099	6.17
	Division 1 Fieldbus: PROFINET, simplex 24 V DC	9492/13-13-31	208875	3.09
	Division 1 Fieldbus: EtherNet/IP™, simplex 24 V DC	9492/13-13-41	208876	3.09
Series 9492/12 - Socket for CPU and Power Module				
	Zone 1 Fieldbus: Modbus TCP, simplex 24 V DC	9492/12-11-11	166176 ▲	2.43
	Zone 1 Fieldbus: EtherNet/IP™, simplex 24 V DC	9492/12-11-41	166322 ▲	2.43
	Zone 1 Fieldbus: PROFINET, simplex 24 V DC	9492/12-11-31	166321 ▲	2.43

Accessories				
Figure	Description	Product Type	Art. No.	Weight lb
Series 9492/12 - Socket for CPU and Power Module				
	Zone 1 Fieldbus: Modbus TCP, redundant 24 V DC	9492/12-11-12	166324 ▲	4.85
Media converter FX op is / TX SC for Cl. I, Div. 2 and Zone 2				
	Media Converter of 10/100 Base-Tx (1 x RJ45 port) to 100 Base-Fx "Ex op is" (1 x FO port SC); Multi mode (up to 4 km range); Webcode: 9721A	9721/13-11-14	220381 ▲	0.53
Unmanaged Switch FX op is / TX SC				
	Unmanaged Switch FX op is to TX; SC plug connector FO cable 4 multi mode (MM), 2 RJ45, Installation in Zone 2	9721/13-42-14	243427 ▲	1.1
FO patch cable				
	Patch cable for connection of IS1+ Ethernet CPU 9441 with media converter 9721; plug LC / SC; length 3.8 ft / 3 m	-	220911 ▲	-

06 b

Accessories for Div. 1 installation on request

Dimensional Drawings (All Dimensions in mm [inches]) – Subject to Alterations

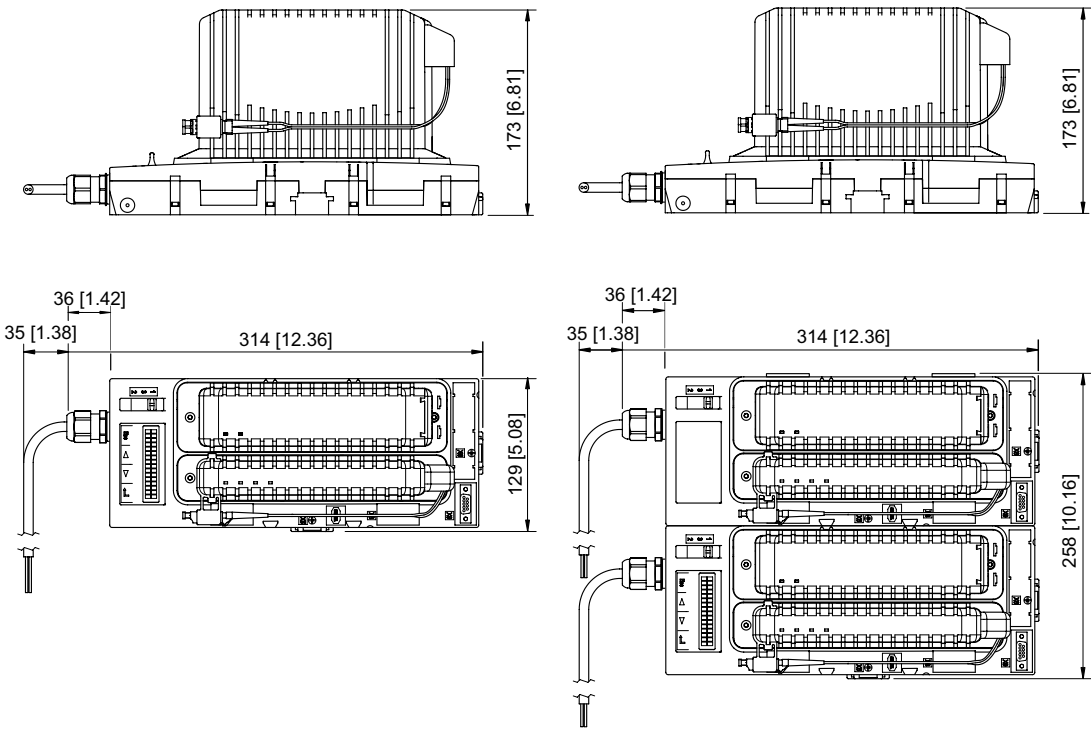

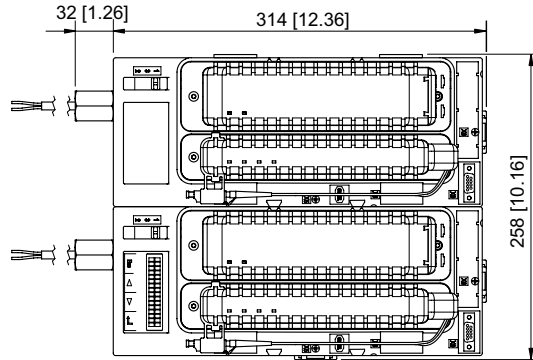
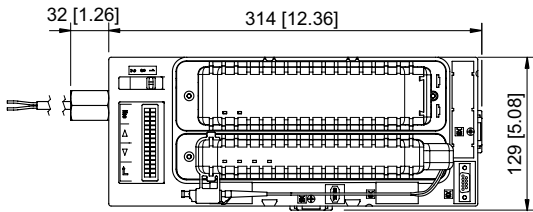
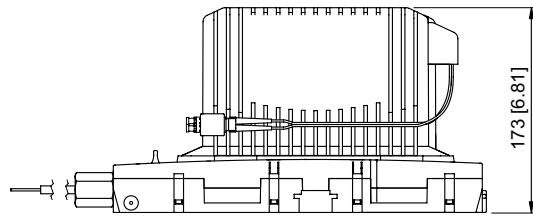
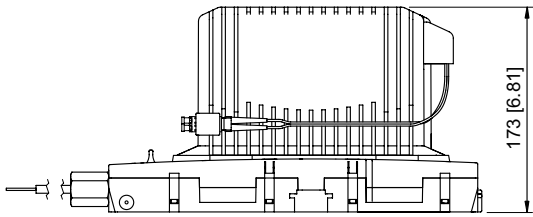

06 b



- For intrinsically safe IS1+ system supply
- For up to eight IS1+ I/O modules and connected field devices
- Power module in Zone 1, Cl. I, II, Div. 1 can be hot swapped

WebCode **9444A**



06 b

The series 9444/12 power module supplies up to eight IS1+ I/O modules, including the connected field circuits, with intrinsically safe energy. A 24 V DC external power supply is required. The power module can be replaced while the system is in operation and without having to disconnect the power supply (i.e. hot swapped).

	NEC® 500 CEC Appendix J					
	Class I		Class II		Class III	
Division	1	2	1	2	1	2
Ex interface	•	•	•	•	•	•
Installation in	•	•				

	CEC Section 18 NEC® 505 NEC® 506					
	Class I					
Zone	0	1	2	20	21	22
Ex interface		•	•		•	•
Installation in		•	•			•

	IECEx / ATEX					
	Zone	0	1	2	20	21
Ex interface		•	•		•	•
Installation in		•	•		•	•

Selection Table					
Installation	Zone 1 / Cl. I, II, Div. 1				
Nominal voltage V_{nom}	Product Type			Art. No.	Weight lb
24 V DC	9444/12-11			166178 ▲	5.31
Please order the 9441/12 CPU and 9492/12; 9492/13 base (see accessories) separately.					

Technical Data	
Explosion Protection	
USA certificate FM	FM17US0332X
CAN certificate FM	FM16CA0134X
USA marking FM	XP; Class I, Div. 1, Groups A,B,C,D; Class I, Zone 1, IIC AIS Class I,II,III, Div. 1, Groups A,B,C,D,E,F,G; Class I, Zone 0, [AEx ia] IIC; T4 at Ta = 65 °C; See Doc. 9441 6 031 001 1
CAN marking FM	XP; Class I, Div. 1, Groups A,B,C,D; Class I, Zone 1 per CEC 18-100 AIS Class I,II,III, Div. 1, Groups A,B,C,D,E,F,G; Class I, Zone 0, [Ex ia] IIC; T4 at Ta = 65 °C; See Doc. 9441 6 031 001 1
IECEx gas explosion protection	Ex d e [ia Ga] IIC T4 Gb
IECEx dust explosion protection	[Ex ia Da] IIIC
Certificates	ATEX (DEK), Brazil (ULB), Canada (FM), EAC (STV), IECEx (DEK), USA (FM)
Ship approval	ABS, CCS, ClassNK, DNV GL, RINA
Auxiliary Power	
Current consumption (without I/O modules)	0.36 A at 24 V DC

Technical Data

Auxiliary Power

Current consumption (with 8 I/O modules)	Approx. 2.6 A at 24 V DC
Power dissipation (without I/O modules)	8.6 W
Power dissipation (8 I/O modules)	14 W

Ambient Conditions

Ambient temperature °F	-4°F ... +149°F
Ambient temperature °C	-20°C ... +65°C
Storage temperature °F	-40°F ... +158°F
Storage temperature °C	-40°C ... +70°C

Mechanical Data

Degree of protection IP (IEC 60529)	IP30
-------------------------------------	------

Accessories

Figure	Description	Product Type	Art. No.	Weight lb
Series 9492/13 - Socket for CPU and Power Module				
	Division 1 Fieldbus: Modbus TCP, simplex 24 V DC	9492/13-13-11	202098	3.09
	Division 1 Fieldbus: Modbus TCP, redundant 24 V DC	9492/13-13-12	202099	6.17
	Division 1 Fieldbus: PROFINET, simplex 24 V DC	9492/13-13-31	208875	3.09
	Division 1 Fieldbus: EtherNet/IP™, simplex 24 V DC	9492/13-13-41	208876	3.09
Series 9492/12 - Socket for CPU and Power Module				
	Zone 1 Fieldbus: Modbus TCP, simplex 24 V DC	9492/12-11-11	166176 ▲	2.43
	Zone 1 Fieldbus: PROFINET, simplex 24 V DC	9492/12-11-31	166321 ▲	2.43
	Zone 1 Fieldbus: EtherNet/IP™, simplex 24 V DC	9492/12-11-41	166322 ▲	2.43
	Zone 1 Fieldbus: Modbus TCP, redundant 24 V DC	9492/12-11-12	166324 ▲	4.85

9491/00-13-70 conduit hub is required and needs to be ordered separately
Accessories for Div. 1 installation on request

Dimensional Drawings (All Dimensions in mm [inches]) – Subject to Alterations

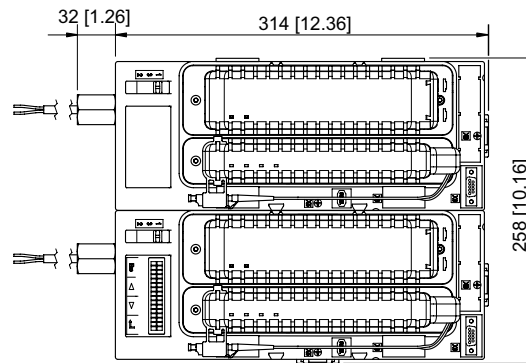
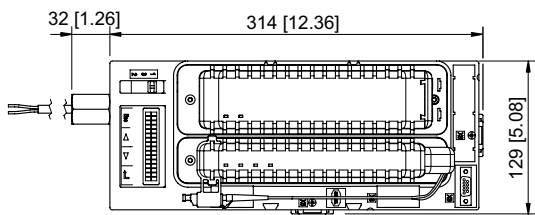
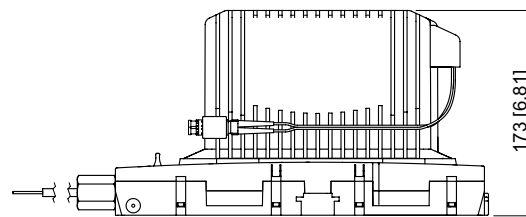
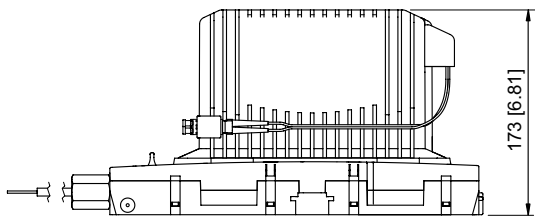
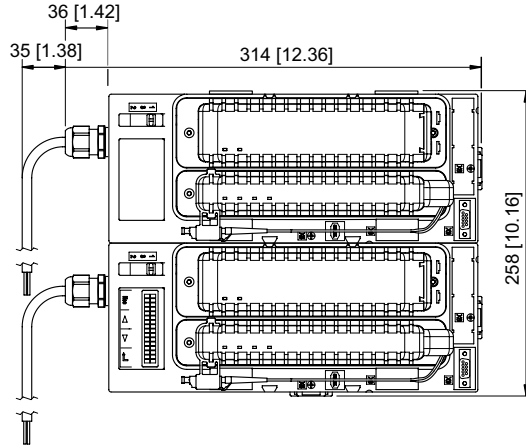
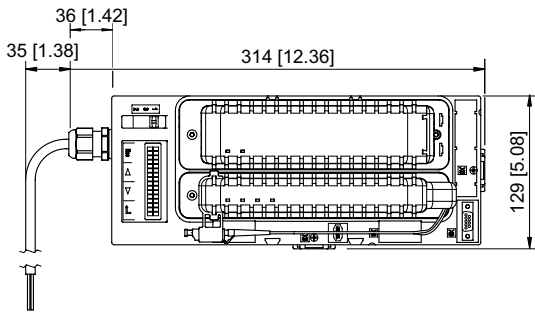
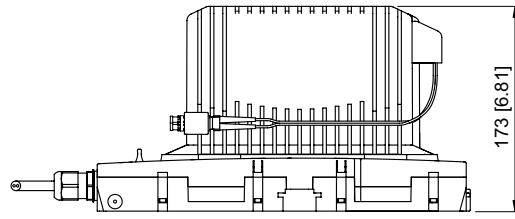
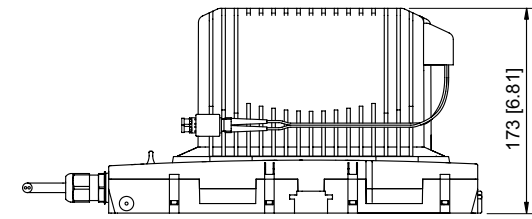

06 b



- Eight channels can be used individually as inputs or outputs
- Intrinsically safe Ex ia IIC inputs/outputs with line fault monitoring and LED error indication for each channel
- Module in Zone 1, Cl. I, II, Div. 1 can be hot swapped

06 b

WebCode 9468A



The 9468/32 series HART Analog Universal Module for Zone 1, Cl. I, II, Div. 1 has eight channels that can be used individually for Ex i operating two-/three-conductor HART transmitters, four-conductor transmitters or control valves/positioners with 0/4 to 20 mA signals. HART communication is bidirectional. All inputs/outputs are short-circuit proof, galvanically separated from the system and individually monitored to check for line faults.

	NEC® 500 CEC Appendix J						CEC Section 18						IECEX / ATEX							
	Class I		Class II		Class III		NEC® 505 Class I			NEC® 506			Zone		Ex interface		Installation in			
Division	1	2	1	2	1	2	Zone	0	1	2	20	21	22	Zone	0	1	2	20	21	22
Ex interface	•	•	•	•	•	•	Ex interface	•	•	•	•	•	•	Ex interface	•	•	•	•	•	•
Installation in	•	•	•	•	•	•	Installation in		•	•		•	•	Installation in		•	•		•	•





Selection Table				
Installation	Zone 1, Zone 2, Zone 21, Zone 22, Cl. I, II, Div. 1, 2 and in the safe area			
Number of channels	Product Type		Art. No.	Weight lb
8 Ex i inputs/outputs	9468/32-08-11		210659 ▲	0.61
Please order terminals separately - see accessories and spare parts.				

Technical Data	
Explosion Protection	
USA certificate FM	FM17US0332X
CAN certificate FM	FM16CA0134X
USA marking FM	IS; Class I,II,III, Div. 1, Groups A,B,C,D,E,F,G; AIS; Class I,II,III, Div. 1, Groups A,B,C,D,E,F,G; Class I, Zone 1, AEx ia [ia] IIC; T4 at Ta = 75 °C; See Doc. 9468 6 031 001 1
CAN marking FM	IS; Class I,II,III, Div. 1, Groups A,B,C,D,E,F,G; AIS; Class I,II,III, Div. 1, Groups A,B,C,D,E,F,G; Class I, Zone 1, Ex ia [ia] IIC; T4 at Ta = 75 °C; See Doc. 9468 6 031 001 1
IECEX gas explosion protection	Ex ia [ia Ga] IIC T4 Gb
IECEX dust explosion protection	[Ex ia Da] IIIC
Certificates	ATEX (DEK), Brazil (ULB), Canada (FM), EAC (STV), IECEX (DEK), India (PESO), Korea (KTL), Russia (Meteorological certificate), USA (FM)
Ship approval	ABS, CCS, ClassNK, DNV GL, RINA
Safety Data	
Max. voltage U _J /V _{cc}	24.4 V

Technical Data	
Safety Data	
Max. current I_o (2-conductor)	80 mA
Max. current I_o (3-conductor)	81.8 mA
Max. power P_o (2-conductor)	488 mW
Max. power P_o (3-conductor)	499 mW
Electrical Data	
Number of channels	8 Ex i inputs/outputs
Channels	each with adjustable parameters as input or output (3-wire, 4-wire transmitters, or active mA-sources occupy 2 channels)
Nominal signal	4 ... 20 mA 0 ... 20 mA
Supply voltage	16 V, at 20 mA for 2-wire transmitters
Communication signal	HART protocol
Connection Ex i field signals	Pluggable, blue terminals, 16-pole, 2.5 mm ² , screw- or spring-type versions with lock
Notes	In order to operate an active 4-wire HART transmitter, a 9164 must be connected between each channel. 9164 is not required when operating 4-wire transmitter without HART communication.
Auxiliary Power	
Current consumption	220 mA (at 20 mA per channel)
Max. power consumption	5.3 W (at 20 mA / channel)
Max. power dissipation outputs	3.7 W (at 20 mA, 500 Ω / channel)
Max. power dissipation inputs	2.7 W (at 20 mA / channel)
Input	
Max. input resistance	14.1 Ω per channel
Output	
Output load resistance max.	750 Ω at 20 mA 700 Ω at 21.8 mA
Output step response (10 ... 90 %)	40 ms
Ambient Conditions	
Ambient temperature °F	-40°F ... +167°F Observe operating instructions
Ambient temperature °C	-40 °C ... +75 °C Observe operating instructions
Mechanical Data	
Degree of protection IP (IEC 60529)	IP20

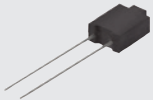
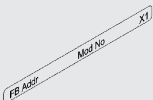
Accessories				
Figure	Description	Product Type	Art. No.	Weight lb
Pluggable terminal				
	2.5 mm ² with lock, 16-pole, screw connector, blue, for connecting the field signals to I/O modules, for intrinsically safe field circuits Labelling: 1 ... 16 Attention: An additional terminal is necessary for I/O module Series 9470 and 9482. Labelling: 17 ... 32	-	162702	0.06
	2.5 mm ² with lock, 16-pole, spring clamp connection, blue, for connecting the field signals to I/O modules, for intrinsically safe field circuits, incl. test jacks Labelling: 1 ... 16 Attention: An additional terminal is necessary for I/O module Series 9470 and 9482. Labelling: 17 ... 32	-	162695 ▲	0.06
mA-Isolating repeater				
	The mA isolating repeaters are used for the connection of 4-wire transmitters to active 2-wire inputs and for the galvanic separation. Input: sink, Ex e Output: sink, Ex i	9164/13-20-06	224365 ▲	0.31
	The mA isolating repeaters are used for the connection of 4-wire transmitters to active 2-wire inputs and for the galvanic separation. Input: sink, Ex i Output: sink, Ex i	9164/13-20-08	224364 ▲	0.2

06 b

Accessories				
Figure	Description	Product Type	Art. No.	Weight lb
Resistor error message suppression				
	The resistors are used to suppress error messages for unused I/O channels Resistance value: 5K6 / 0.5 W Suitable for: AIM 9468; DIOM 9470; DIOM 9471; DIOM 9472; DOM 9475 For intrinsically safe circuits (simple apparatus according to EN 60079-11)	-	244911	-
	The resistors are used to suppress error messages for unused I/O channels Resistance value: 62R / 0.5 W Suitable for: AOM 9468; TIM 9482	-	244912	-
Labelling strips				
	"FB Addr ... Mod No ..." for pluggable terminal, 26 pieces on the sheet	-	162788	-
DIN A4 sheet				
	For the label plate on I/O modules, 6 labels per sheet Print IS Wizard, packaging unit = 20 sheets	-	162832	-
Warning sign				
	"Clean modules only with a damp cloth."	-	162796	-
Partition				
	For mounting between intrinsically safe and non-intrinsically safe connections of the I/O modules, in order to adhere to the required 50 mm distance	-	220101 ▲	0.02

Dimensional Drawings (All Dimensions in mm [inches]) – Subject to Alterations

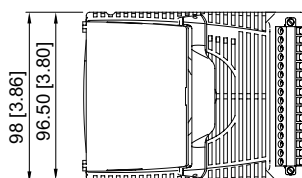
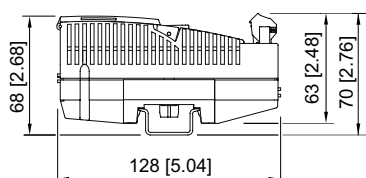



- Eight channels can be used individually as inputs or outputs
- Intrinsically safe Ex ia IIC inputs/outputs with line fault monitoring
- Module in Zone 2, Cl. I, II, Div. 2 can be hot swapped

WebCode **9468B**



06 b

The 9468/33 series HART Analog Universal Module for Zone 2, Cl. I, II, Div. 2 has eight channels that can be used individually for Ex i operating two-/three-conductor HART transmitters, four-conductor transmitters or control valves/positioners with 0/4 to 20 mA signals. HART communication is bidirectional. All inputs/outputs are short-circuit proof, galvanically separated from the system and individually monitored to check for line faults.

	NEC® 500 CEC Appendix J					
	Class I		Class II		Class III	
Division	1	2	1	2	1	2
Ex interface	•	•	•	•	•	•
Installation in		•		•		•

	CEC Section 18 NEC® 505 NEC® 506					
	Class I					
Zone	0	1	2	20	21	22
Ex interface	•	•	•	•	•	•
Installation in			•			•





	IECEX / ATEX					
	Zone	0	1	2	20	21
Ex interface	•	•	•	•	•	•
Installation in			•			•





Selection Table			
Installation	Zone 2, Zone 22, Cl. I, II, Div. 2 and in the safe area		
Number of channels	Product Type	Art. No.	Weight lb
8 Ex i inputs/outputs	9468/33-08-10	210660	0.61
Please order terminals separately - see accessories and spare parts.			

Technical Data	
Explosion Protection	
USA certificate FM	FM17US0332X
CAN certificate FM	FM16CA0134X
USA marking FM	NI, Class I,II,III, Div. 2, Groups A,B,C,D,E,F,G; AIS, Class I,II,III, Div. 1, Groups A,B,C,D,E,F,G; Class I, Zone 2, AEx nA ia [ia] IIC; T4 at Ta = 75 °C; See Doc. 9468 6 031 002 1
CAN marking FM	NI, Class I,II,III, Div. 2, Groups A,B,C,D,E,F,G; AIS, Class I,II,III, Div. 1, Groups A,B,C,D,E,F,G; Class I, Zone 2, Ex nA ia [ia] IIC; T4 at Ta = 75 °C; See Doc. 9468 6 031 002 1
IECEX gas explosion protection	Ex nA ia [ia Ga] IIC T4 Gc
IECEX dust explosion protection	[Ex ia Da] IIIC
Certificates	ATEX (DEK), Brazil (ULB), Canada (FM), EAC (STV), IECEX (DEK), India (PESO), Korea (KTL), Russia (Meteorological certificate), USA (FM)
Ship approval	ABS, CCS, ClassNK, DNV GL, RINA
Safety Data	
Max. voltage U ₀ /V _{cc}	24.4 V

06 b

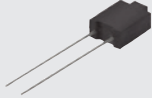
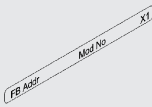
Technical Data	
Safety Data	
Max. current I _o (2-conductor)	80 mA
Max. current I _o (3-conductor)	81.8 mA
Max. power P _o (2-conductor)	488 mW
Max. power P _o (3-conductor)	499 mW
Electrical Data	
Number of channels	8 Ex i inputs/outputs
Channels	each with adjustable parameters as input or output (3-wire, 4-wire transmitters, or active mA-sources occupy 2 channels)
Nominal signal	4 ... 20 mA 0 ... 20 mA
Supply voltage	16 V, at 20 mA for 2-wire transmitters
Communication signal	HART protocol
Connection Ex i field signals	Pluggable, blue terminals, 16-pole, 2.5 mm ² , screw- or spring-type versions with lock
Notes	In order to operate an active 4-wire HART transmitter, a 9164 must be connected between each channel. 9164 is not required when operating 4-wire transmitter without HART communication.
Auxiliary Power	
Current consumption	220 mA (at 20 mA per channel)
Max. power consumption	5.3 W (at 20 mA / channel)
Max. power dissipation outputs	3.7 W (at 20 mA, 500 Ω / channel)
Max. power dissipation inputs	2.7 W (at 20 mA / channel)
Input	
Max. input resistance	14.1 Ω per channel
Output	
Output load resistance max.	750 Ω at 20 mA 700 Ω at 21.8 mA
Output step response (10 ... 90 %)	40 ms
Ambient Conditions	
Ambient temperature °F	-40°F ... +167°F Observe operating instructions
Ambient temperature °C	-40 °C ... +75 °C Observe operating instructions
Mechanical Data	
Degree of protection IP (IEC 60529)	IP20

Accessories				
Figure	Description	Product Type	Art. No.	Weight lb
Pluggable terminal				
	2.5 mm ² with lock, 16-pole, screw connector, blue, for connecting the field signals to I/O modules, for intrinsically safe field circuits Labelling: 1 ... 16 Attention: An additional terminal is necessary for I/O module Series 9470 and 9482. Labelling: 17 ... 32	-	162702	0.06
	2.5 mm ² with lock, 16-pole, spring clamp connection, blue, for connecting the field signals to I/O modules, for intrinsically safe field circuits, incl. test jacks Labelling: 1 ... 16 Attention: An additional terminal is necessary for I/O module Series 9470 and 9482. Labelling: 17 ... 32	-	162695 ▲	0.06
mA-Isolating repeater				
	The mA isolating repeaters are used for the connection of 4-wire transmitters to active 2-wire inputs and for the galvanic separation. Input: sink, Ex e Output: sink, Ex i	9164/13-20-06	224365 ▲	0.31
	The mA isolating repeaters are used for the connection of 4-wire transmitters to active 2-wire inputs and for the galvanic separation. Input: sink, Ex i Output: sink, Ex i	9164/13-20-08	224364 ▲	0.2

Accessories				
Figure	Description	Product Type	Art. No.	Weight lb
Resistor error message suppression				
	The resistors are used to suppress error messages for unused I/O channels Resistance value: 5K6 / 0.5 W Suitable for: AIM 9468; DIOM 9470; DIOM 9471; DIOM 9472; DOM 9475 For intrinsically safe circuits (simple apparatus according to EN 60079-11)	-	244911	-
	The resistors are used to suppress error messages for unused I/O channels Resistance value: 62R / 0.5 W Suitable for: AOM 9468; TIM 9482	-	244912	-
Labelling strips				
	"FB Addr ... Mod No ..." for pluggable terminal, 26 pieces on the sheet	-	162788	-
DIN A4 sheet				
	For the label plate on I/O modules, 6 labels per sheet Print IS Wizard, packaging unit = 20 sheets	-	162832	-
Warning sign				
	"Clean modules only with a damp cloth."	-	162796	-
Partition				
	For mounting between intrinsically safe and non-intrinsically safe connections of the I/O modules, in order to adhere to the required 50 mm distance	-	220101 ▲	0.02

06 b

Dimensional Drawings (All Dimensions in mm [inches]) – Subject to Alterations

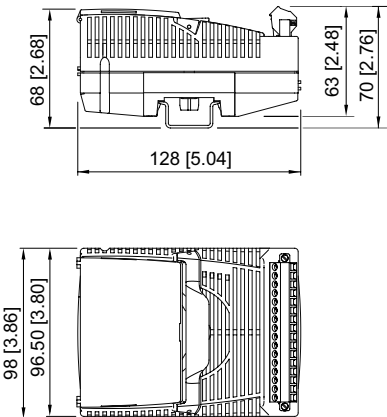



- Eight channels can be used as analogue inputs or outputs, and 4 of these channels can be used as binary inputs or outputs
- Inputs/outputs with line fault monitoring, an LED fault and status display for each channel and SIL2 shutdown input
- Module in Zone 2, Cl. I, Div. 2 can be replaced during operation (hot swap)

06 b

WebCode 9469A



The HART 9469/35 universal module for Zone 2, Cl. I, Div. 2 has 8 channels that are suitable for separately operating 2-/3-/4-line HART transmitters, control valves/position regulators and operating 3-line proximity switches and 24 V / 0.5 A binary output signal can be used.

HART communication is bidirectional. All inputs/outputs are short-circuit proof, galvanically separated from the system and individually monitored to check for line faults.

	NEC® 500 CEC Appendix J						CEC Section 18						IECEX / ATEX					
	Class I		Class II		Class III		NEC® 505 Class I			NEC® 506			Zone		Ex interface		Installation in	
Division	1	2	1	2	1	2	0	1	2	20	21	22	0	1	2	20	21	22
Ex interface		•							•						•			
Installation in		•							•						•			

Selection Table				
Installation	Zone 2, Cl. I, Div. 2 and in the safe area (non-intrinsically safe field circuits)			
Number of channels	Product Type		Art. No.	Weight lb
(adjustable parameters in pairs) 8 Ex ec/nA universal input/output	9469/35-08-12		230184 ▲	0.55
Please order terminal separately - see accessories and spare parts				

Technical Data	
Explosion Protection	
USA certificate FM	FM17US0332X
CAN certificate FM	FM16CA0134X
USA marking FM	NI; Class I, Div. 2, Groups A,B,C,D; Class I, Zone 2, AEx ec ic IIC T4 Gc; Ta = -40°C ... +75°C See Doc. 9496 6 031 001 1
CAN marking FM	NI; Class. I, Div. 2, Groups A,B,C,D; Class I, Zone 2, Ex ec ic IIC T4 Gc; Ta = -40°C ... +75°C See Doc. 9496 6 031 001 1
IECEX gas explosion protection	Ex ec/nA ic [ia Ga] IIC T4 Gc
Certificates	ATEX (DEK), Canada (FM), EAC (Sertium), IECEX (DEK), Korea (KTL), SIL (exida), USA (FM)
Electrical Data	
Max. number of 2-conductor analogue inputs/ outputs	8 (channels 0 ... 7)
Max. number of 3/4-conductor analogue inputs	4 (channels 4 ... 7)

Technical Data

Electrical Data

Max. number of 3-conductor PNP inputs	4 (channels 4 ... 7)
Max. number of binary outputs	4 (channels 4 ... 7)
Analogue digital communication	HART protocol
Digital communication note	up to Version 7.x, only at 4 to 20 mA
External supply voltage U_H (X0)	18 ... 32 V DC (nominal voltage of 24 V)
Max. current consumption (X0)	4 x 0.5 A (depends on the total current of the binary outputs)
Control input suitability (X0)	Disconnection up to SIL 2. low demand (IEC 61508)
Control input function (X0)	"Plant STOP" to switch off all outputs

Auxiliary Power

Power supply connection	BusRail types 9494
Auxiliary power version	Intrinsically safe Ex ia via BusRail
Current consumption	250 mA
Max. power consumption	6 W
Max. power dissipation outputs	5.9 W

Input

Analogue input signal type	2/3/4-conductor transmitter
Analogue input nominal signal	0 ... 20 mA 4 ... 20 mA
Analogue input max. input resistance	200 Ω per channel
Binary input signal type	3-conductor PNP initiators 2-conductor 24 V contacts
Binary input signal type	corresponds to the ext. supply voltage U_H (X0)
Binary input internal resistance	11 k Ω

Output

Analogue output signal type	2-conductor transmitter
Analogue output nominal signal	0 ... 20 mA 4 ... 20 mA
Analogue output max. input resistance	200 Ω per channel
Analogue output max. load resistance	750 Ω at 20 mA 700 Ω at 21.8 mA
Binary output signal type	2-conductor (24 V / 0.5 A)
Binary output supply voltage	corresponds to the ext. supply voltage U_H - 0.7 V (X0)
Binary output current	30 mA ... 0.5 A per channel (electronically limited)
Binary output connectable loads	ohmic inductive capacitive



Ambient Conditions

Ambient temperature °F	-4°F ... +167°F
Ambient temperature °C	-40°C ... +75°C





Mechanical Data

Degree of protection IP (IEC 60529)	IP20
-------------------------------------	------

Accessories

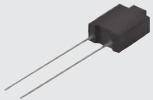
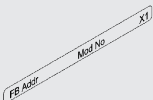
Figure	Description	Art. No.	Weight lb
Plug-in terminal			
	1.5 mm ² with lock, 24-pole, spring clamp connection, black for connecting the field signals to I/O modules, for non-intrinsically safe field circuits Caution: only for 9469, 9471 and 9472 I/O modules Labelling: 1 ... 24	245090 ▲	-
	1.5 mm ² with lock, 24-pole, spring clamp connection, black for connecting the field signals to I/O modules, for non-intrinsically safe field circuits Caution: only for 9469, 9471 and 9472 I/O modules Labelling: 25 ... 48	245091 ▲	-

06 b

Accessories			
Figure	Description	Art. No.	Weight lb
Resistor error message suppression			
	The resistors are used to suppress error messages for unused I/O channels Resistance value: 5K6 / 0.5 W Suitable for: AIM 9468; DIOM 9470; DIOM 9471; DIOM 9472; DOM 9475 For intrinsically safe circuits (simple apparatus according to EN 60079-11)	244911	-
	The resistors are used to suppress error messages for unused I/O channels Resistance value: 62R / 0.5 W Suitable for: AOM 9468; TIM 9482	244912	-
Labelling strips			
	"FB Addr ... Mod No ..." for pluggable terminal, 26 pieces on the sheet	162788	-
DIN A4 sheet			
	For the label plate on I/O modules, 6 labels per sheet Print IS Wizard, packaging unit = 20 sheets	162832	-
Partition			
	For mounting between intrinsically safe and non-intrinsically safe connections of the I/O modules, in order to adhere to the required 50 mm distance	220101 ▲	0.02
Warning sign			
	"Clean modules only with a damp cloth."	162796	-

Dimensional Drawings (All Dimensions in mm [inches]) – Subject to Alterations

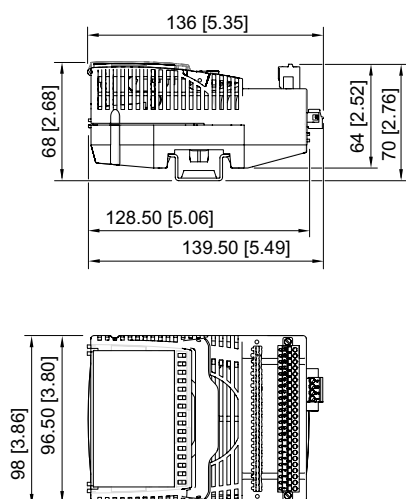



- Sixteen channels can be used in pairs as inputs or outputs
- Intrinsically safe Ex ia IIC inputs/outputs with line fault monitoring and LED error and status indication for each channel
- Module in Zone 1, Cl. I, II, Div. 1 can be hot swapped

WebCode 9470C



06 b

The 9470/32 series digital input/output module for Zone 1, Cl. I, II, Div. 1 has 16 channels, which can be used in pairs for Ex i operation as inputs for contacts and NAMUR proximity sensors (EN 60947-5-6) or as outputs for indicator lamps and low-power solenoid valves. Eight inputs can be used for frequencies of up to 20 kHz, and four can be used for detecting the direction of rotation.

All inputs/outputs are short-circuit proof and galvanically separated from the system.

	NEC® 500 CEC Appendix J					
	Class I		Class II		Class III	
Division	1	2	1	2	1	2
Ex interface	•	•	•	•	•	•
Installation in	•	•	•	•	•	•

	CEC Section 18					
	NEC® 505			NEC® 506		
	Class I					
Zone	0	1	2	20	21	22
Ex interface	•	•	•	•	•	•
Installation in		•	•		•	•







	IECEX / ATEX					
	Class I		Class II		Class III	
Zone	0	1	2	20	21	22
Ex interface	•	•	•	•	•	•
Installation in		•	•		•	•



Selection Table			
Installation	in Zone 1, Zone 2, Zone 21, Zone 22, Cl. I, II, Div. 1, 2 and in safe areas		
Number of channels	Product Type	Art. No.	Weight lb
(adjustable parameters in pairs) 16 Ex i inputs/outputs	9470/32-16-11	210447 ▲	0.61
Please order 2 terminals separately - see accessories and spare parts			

Technical Data	
Explosion Protection	
USA certificate FM	FM17US0332X
CAN certificate FM	FM16CA0134X
USA marking FM	IS; Class I,II,III, Div. 1, Groups A,B,C,D,E,F,G; AIS; Class I,II,III, Div. 1, Groups A,B,C,D,E,F,G; Class I, Zone 1, AEx ia [ia] IIC; T4 at Ta = 75 °C; See Doc. 9470 6 031 001 1
CAN marking FM	IS; Class I,II,III, Div. 1, Groups A,B,C,D,E,F,G; AIS; Class I,II,III, Div. 1, Groups A,B,C,D,E,F,G; Class I, Zone 1, Ex ia [ia] IIC; T4 at Ta = 75 °C; See Doc. 9470 6 031 001 1
IECEX gas explosion protection	Ex ia [ia Ga] IIC T4 Gb
IECEX dust explosion protection	[Ex ia Da] IIIC
Certificates	ATEX (DEK), Brazil (ULB), Canada (FM), EAC (STV), IECEX (DEK), India (PESO), Korea (KTL), USA (FM)
Ship approval	ABS, CCS, ClassNK, DNV GL, RINA

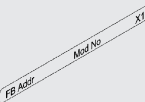
06 b

Technical Data	
Safety Data	
Max. voltage U_i/V_{oc}	9.8 V
Max. current I_o (Ex ia)	10.4 mA
Max. power P_o (Ex ia)	25.5 mW
Auxiliary Power	
Current consumption	120 mA
Max. power consumption	2.5 W
Max. power dissipation outputs	2.5 W
Input	
Supply voltage	8.2 V
Function	Up/down counter Frequency with direction
Signal input	EN 60947 input (NAMUR)
Notes	IEC 60947-5-6-1999 (NAMUR), 3-conductor PNP proximity switches and active 24 V signals with and without 47 kΩ resistance connected in parallel
Output	
Output rated operation	6 V / 2 mA
Notes	Output characteristic, see data sheet on the Internet r-stahl.com (WebCode 9470C)
Ambient Conditions	
Ambient temperature °F	-40°F ... +167°F
Ambient temperature °C	-40°C ... +75°C

Accessories				
Figure	Description	Product Type	Art. No.	Weight lb
Pluggable terminal				
	2.5 mm² with lock, 16-pole, screw connector, blue, for connecting the field signals to I/O modules, for intrinsically safe field circuits Labelling: 1 ... 16 Attention: An additional terminal is necessary for I/O module Series 9470 and 9482. Labelling: 17 ... 32	-	162702	0.06
	2.5 mm² with lock, 16-pole, screw connector, blue for connecting the field signals to I/O modules, for intrinsically safe field circuits Labelling: 17 ... 32	-	162718	0.06
	2.5 mm² with lock, 16-pole, spring clamp connection, blue, for connecting the field signals to I/O modules, for intrinsically safe field circuits, incl. test jacks Labelling: 1 ... 16 Attention: An additional terminal is necessary for I/O module Series 9470 and 9482. Labelling: 17 ... 32	-	162695 ▲	0.06
	2.5 mm² with lock, 16-pole, spring clamp connection, blue for connecting the field signals to I/O modules, for intrinsically safe field circuits, incl. test jacks Labelling: 17 ... 32	-	162716 ▲	0.06
Indicator lamp				
	Single electrical equipment for intrinsically safe circuits according to EN 60079-11	8010/C1661	228026	0.08
Labelling strips				
	"FB Addr ... Mod No ..." for pluggable terminal, 26 pieces on the sheet	-	162788	-
DIN A4 sheet				
	For the label plate on I/O modules, 6 labels per sheet Print IS Wizard, packaging unit = 20 sheets	-	162832	-

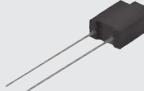
Accessories				
Figure	Description	Product Type	Art. No.	Weight lb
Partition				
	For mounting between intrinsically safe and non-intrinsically safe connections of the I/O modules, in order to adhere to the required 50 mm distance	-	220101 ▲	0.02
Warning sign				
	"Clean modules only with a damp cloth."	-	162796	-
Resistor error message suppression				
	The resistors are used to suppress error messages for unused I/O channels Resistance value: 5K6 / 0.5 W Suitable for: AIM 9468; DIOM 9470; DIOM 9471; DIOM 9472; DOM 9475 For intrinsically safe circuits (simple apparatus according to EN 60079-11)	-	244911	-

06 b

Technical Drawings – Subject to Alterations

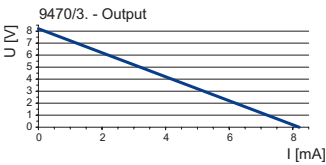

Output characteristic

Dimensional Drawings (All Dimensions in mm [inches]) – Subject to Alterations

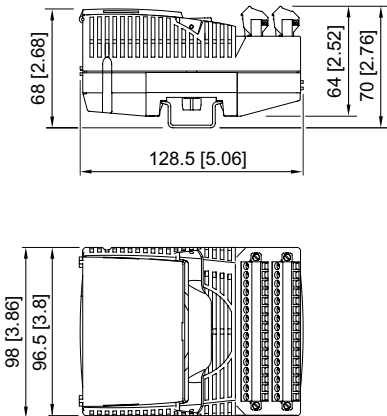



- Sixteen channels can be used in pairs as inputs or outputs
- Intrinsically safe Ex ia IIC inputs/outputs with line fault monitoring
- Module in Zone 2, Cl. I, II, Div. 2 can be hot swapped

06 b

WebCode 9470D



The 9470/33 series digital input/output module for Zone 2, Cl. I, II, Div. 2 has 16 channels, which can be used in pairs for Ex i operation as inputs for contacts and NAMUR proximity sensors (EN 60947-5-6) or as outputs for indicator lamps and low-power solenoid valves. Eight inputs can be used for frequencies of up to 20 kHz, and four can be used for detecting the direction of rotation.







All inputs/outputs are short-circuit proof and galvanically separated from the system.

	NEC® 500 CEC Appendix J						CEC Section 18						IECEX / ATEX					
	Class I		Class II		Class III		NEC® 505 Class I			NEC® 506			Zone 0		Zone 1		Zone 2	
Division	1	2	1	2	1	2	0	1	2	20	21	22	0	1	2	20	21	22
Ex interface	•	•	•	•	•	•			•	•	•	•	•	•	•	•	•	•
Installation in		•		•		•			•		•				•		•	•

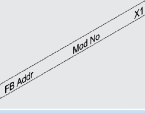

Selection Table				
Installation	in Zone 2, Zone 21, Zone 22, Cl. I, II, Div. 2 and in safe areas			
Number of channels	Product Type		Art. No.	Weight lb
16 Ex i inputs/outputs (adjustable parameters in pairs)	9470/33-16-10		210448	0.61
Please order 2 terminals separately - see accessories and spare parts				

Technical Data	
Explosion Protection	
USA certificate FM	FM17US0332X
CAN certificate FM	FM16CA0134X
USA marking FM	NI, Class I,II,III, Div. 2, Groups A,B,C,D,E,F,G; AIS, Class I,II,III, Div. 1, Groups A,B,C,D,E,F,G; Class I, Zone 2, AEx nA ia [ia] IIC; T4 at Ta = 75 °C; See Doc. 9470 6 031 002 1
CAN marking FM	NI, Class I,II,III, Div. 2, Groups A,B,C,D,E,F,G; AIS, Class I,II,III, Div. 1, Groups A,B,C,D,E,F,G; Class I, Zone 2, Ex nA ia [ia] IIC; T4 at Ta = 75 °C; See Doc. 9470 6 031 002 1
IECEX gas explosion protection	Ex nA ia [ia Ga] IIC T4 Gc
IECEX dust explosion protection	[Ex ia Da] IIIC
Certificates	ATEX (DEK), Brazil (ULB), Canada (FM), EAC (STV), IECEX (DEK), India (PESO), Korea (KTL), USA (FM)
Ship approval	ABS, CCS, ClassNK, DNV GL, RINA

Technical Data	
Safety Data	
Max. voltage U_0/V_{oc}	9.8 V
Max. current I_0 (Ex ia)	10.4 mA
Max. power P_0 (Ex ia)	25.5 mW
Auxiliary Power	
Current consumption	120 mA
Max. power consumption	2.5 W
Max. power dissipation outputs	2.5 W
Input	
Signal input	EN 60947 input (NAMUR)
Supply voltage	8.2 V
Function	Frequency with direction Up/down counter
Output	
Output rated operation	6 V / 2 mA
Notes	Output characteristic, see data sheet on the Internet r-stahl.com (WebCode 9470D)
Ambient Conditions	
Ambient temperature °F	-40°F ... +167°F
Ambient temperature °C	-40°C ... +75°C

Accessories				
Figure	Description	Product Type	Art. No.	Weight lb
Pluggable terminal				
	2.5 mm ² with lock, 16-pole, screw connector, blue, for connecting the field signals to I/O modules, for intrinsically safe field circuits Labelling: 1 ... 16 Attention: An additional terminal is necessary for I/O module Series 9470 and 9482. Labelling: 17 ... 32	-	162702	0.06
	2.5 mm ² with lock, 16-pole, screw connector, blue for connecting the field signals to I/O modules, for intrinsically safe field circuits Labelling: 17 ... 32	-	162718	0.06
	2.5 mm ² with lock, 16-pole, spring clamp connection, blue, for connecting the field signals to I/O modules, for intrinsically safe field circuits, incl. test jacks Labelling: 1 ... 16 Attention: An additional terminal is necessary for I/O module Series 9470 and 9482. Labelling: 17 ... 32	-	162695 ▲	0.06
	2.5 mm ² with lock, 16-pole, spring clamp connection, blue for connecting the field signals to I/O modules, for intrinsically safe field circuits, incl. test jacks Labelling: 17 ... 32	-	162716 ▲	0.06
Indicator lamp				
	Single electrical equipment for intrinsically safe circuits according to EN 60079-11	8010/C1661	228026	0.08
Labelling strips				
	"FB Addr ... Mod No ..." for pluggable terminal, 26 pieces on the sheet	-	162788	-
DIN A4 sheet				
	For the label plate on I/O modules, 6 labels per sheet Print IS Wizard, packaging unit = 20 sheets	-	162832	-

06 b

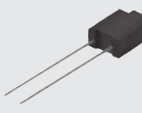
Accessories				
Figure	Description	Product Type	Art. No.	Weight lb
Partition				
	For mounting between intrinsically safe and non-intrinsically safe connections of the I/O modules, in order to adhere to the required 50 mm distance	-	220101 ▲	0.02
Warning sign				
	"Clean modules only with a damp cloth."	-	162796	-
Resistor error message suppression				
	The resistors are used to suppress error messages for unused I/O channels Resistance value: 5K6 / 0.5 W Suitable for: AIM 9468; DIOM 9470; DIOM 9471; DIOM 9472; DOM 9475 For intrinsically safe circuits (simple apparatus according to EN 60079-11)	-	244911	-

Technical Drawings – Subject to Alterations

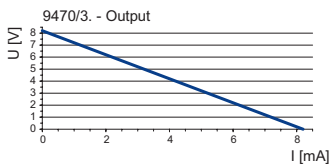

Output characteristic

Dimensional Drawings (All Dimensions in mm [inches]) – Subject to Alterations

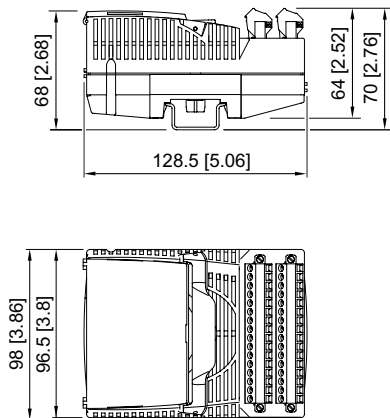



- Sixteen channels can be used in pairs as inputs or outputs
- Inputs/outputs with line fault monitoring and LED error and status indication for each channel
- Module in Zone 2, Cl. I, Div. 2 can be hot swapped

WebCode 9471B



06 b

The 9471/35 series digital input/output module for Zone 2, Cl. I, Div. 2 has 16 channels, which can be used in pairs for operation as inputs for contacts, NAMUR proximity sensors (EN 60947-5-6) and PNP proximity switches or as outputs for indicator lamps and low-power solenoid valves. Eight inputs can be used for frequencies of up to 20 kHz, and four can be used for detecting the direction of rotation. All inputs/outputs are short-circuit proof and galvanically separated from the system.

	NEC® 500 CEC Appendix J					
	Class I		Class II		Class III	
Division	1	2	1	2	1	2
Ex interface		•				
Installation in		•				

	CEC Section 18					
	NEC® 505			NEC® 506		
	Class I					
Zone	0	1	2	20	21	22
Ex interface			•			
Installation in			•			





	IECEx / ATEX					
	0	1	2	20	21	22
Zone						
Ex interface			•			
Installation in			•			

Selection Table				
Installation	Zone 2, Cl. I, Div. 2 and safe area			
Number of channels	Product Type		Art. No.	Weight lb
(adjustable parameters in pairs) 16 Ex ec/nA inputs/outputs	9471/35-16-11		230225 ▲	0.61
Please order 2 terminals separately - see accessories and spare parts				

Technical Data	
Explosion Protection	
USA certificate FM	FM17US0332X
CAN certificate FM	FM16CA0134X
USA marking FM	NI; Class I, Div. 2, Groups A,B,C,D; Class I, Zone 2, AEx ec ic IIC T4 Gc; Ta = -40°C ... +75°C; See Doc. 9471 6 031 001 1
CAN marking FM	NI; Class. I, Div. 2, Groups A,B,C,D; Class. I, Zone 2, Ex ec ic IIC T4 Gc; Ta = -40°C ... +75°C; See Doc. 9471 6 031 001 1
IECEx gas explosion protection	Ex ec/nA ic [ia Ga] IIC T4 Gc
Certificates	ATEX (DEK), Canada (FM), EAC (Sertium), IECEx (DEK), India (PESO), Korea (KTL), USA (FM)
Ship approval	DNV GL
Electrical Data	
Max. number of 3-conductor PNP inputs	16 (channels 1... 15)

06 b

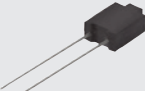
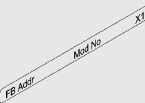
Technical Data	
Auxiliary Power	
Current consumption	90 mA
Max. power consumption	2.2 W
Power dissipation max.	0.7 W
Input	
Max. number of frequency inputs	8 (channel 8 ... 15)
Notes	Max. supply voltage PNP: 24 V externally supplied IEC 60947-5-6-1999 (NAMUR), 3-conductor PNP proximity switches and active 24 V signals with and without 47 kΩ resistance connected in parallel
Output	
Binary output signal type	2-conductor (6 V / 2 mA)
Notes	Output characteristics, see data sheet online at r-stahl.com (WebCode 9471B)
Ambient Conditions	
Ambient temperature °F	-40°F ... +167°F
Ambient temperature °C	-40°C ... +75°C
Mechanical Data	
Degree of protection IP (IEC 60529)	IP20

Accessories			
Figure	Description	Art. No.	Weight lb
Plug-in terminal			
	1.5 mm ² with lock, 24-pole, spring clamp connection, black for connecting the field signals to I/O modules, for non-intrinsically safe field circuits Caution: only for 9469, 9471 and 9472 I/O modules Labelling: 1 ... 24	245090 ▲	-
	1.5 mm ² with lock, 24-pole, spring clamp connection, black for connecting the field signals to I/O modules, for non-intrinsically safe field circuits Caution: only for 9469, 9471 and 9472 I/O modules Labelling: 25 ... 48	245091 ▲	-
Resistor error message suppression			
	The resistors are used to suppress error messages for unused I/O channels Resistance value: 5K6 / 0.5 W Suitable for: AIM 9468; DIOM 9470; DIOM 9471; DIOM 9472; DOM 9475 For intrinsically safe circuits (simple apparatus according to EN 60079-11)	244911	-
Labelling strips			
	"FB Addr ... Mod No ..." for pluggable terminal, 26 pieces on the sheet	162788	-
DIN A4 sheet			
	For the label plate on I/O modules, 6 labels per sheet Print IS Wizard, packaging unit = 20 sheets	162832	-
Partition			
	For mounting between intrinsically safe and non-intrinsically safe connections of the I/O modules, in order to adhere to the required 50 mm distance	220101 ▲	0.02

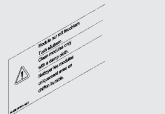
Accessories			
Figure	Description	Art. No.	Weight lb
	"Clean modules only with a damp cloth."	162796	-

Technical Drawings – Subject to Alterations

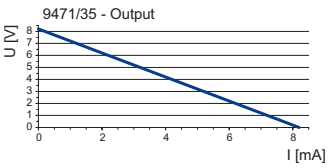

Output characteristic

06 b

Dimensional Drawings (All Dimensions in mm [inches]) – Subject to Alterations

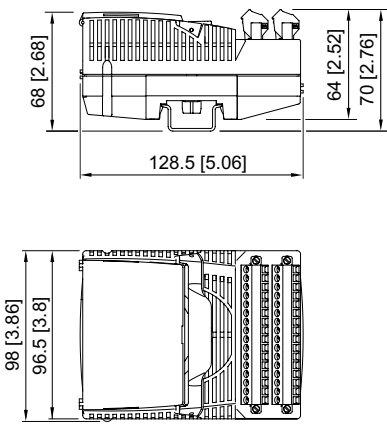



- Sixteen channels can be used in pairs as inputs or outputs (24 V / 0.5 A)
- Inputs/outputs with line fault monitoring and LED error and status indication for each channel plus SIL 2 shutdown input
- Module in Zone 2, Cl. I, Div. 2 can be hot swapped

06 b

WebCode 9472A



The 9472/35 24 V series digital input/output module for Zone 2, Cl. I, Div. 2 has 16 channels, which can be used in pairs for operation as inputs for contacts and PNP or NAMUR proximity sensors (EN 60947-5-6) or as outputs for solenoid valves up to 24 V/0.5 A. Eight inputs can be used for frequencies of up to 20 kHz, and four can be used for detecting the direction of rotation.

All inputs/outputs are short-circuit proof and galvanically separated from the system. Additional control input for "System OFF" (IEC61508 / through SIL2)





	NEC® 500 CEC Appendix J						CEC Section 18						IECEX / ATEX					
	Class I		Class II		Class III		NEC® 505 Class I			NEC® 506			Zone		Zone		Zone	
Division	1	2	1	2	1	2	0	1	2	20	21	22	0	1	2	20	21	22
Ex interface		•							•						•			
Installation in		•							•						•			

Selection Table				
Installation	Zone 2, Cl. I, Div. 2			
Number of channels		Product Type	Art. No.	Weight lb
16 Ex ec/nA inputs/outputs (adjustable parameters in pairs)		9472/35-16-12	230239 ▲	0.61
Please order 2 terminals separately - see accessories and spare parts				

Technical Data	
Explosion Protection	
USA certificate FM	FM17US0332X
CAN certificate FM	FM16CA0134X
USA marking FM	NI; Class I, Div. 2, Groups A,B,C,D; Class I, Zone 2, AEx ec ic IIC T4 Gc; Ta = -40°C ... +75°C; See Doc. 9471 6 031 001 1
CAN marking FM	NI; Class I, Div. 2, Groups A,B,C,D; Class I, Zone 2, Ex ec ic IIC T4 Gc; Ta = -40°C ... +75°C; See Doc. 9471 6 031 001 1
IECEX gas explosion protection	Ex ec/nA ic [ia Ga] IIC T4 Gc
Certificates	ATEX (DEK), Canada (FM), EAC (Sertium), IECEX (DEK), India (PESO), Korea (KTL), SIL (exida), USA (FM)
Electrical Data	
Max. number of 3-conductor PNP inputs	16 (channels 1... 15)

Technical Data	
Auxiliary Power	
Current consumption	90 mA
Max. power consumption	2.2 W
Power dissipation max.	Output: 5.4 W Input: 1.4 W
Input	
Max. number of frequency inputs	8 (channel 8 ... 15)
Notes	<p>Max. supply voltage PNP: corresponds to the external supply voltage U_H (X0)</p> <p>External supply voltage U_H (X0): 18 ... 32 V DC (nominal voltage 24 V)</p> <p>Max. current consumption (X0): 4 x 0.5 A (depending on the total current of the binary outputs)</p> <p>IEC 60947-5-6-1999 (NAMUR), 3-conductor PNP proximity switches and active 24 V signals with and without 47 kΩ resistance connected in parallel</p>
Output	
Supply voltage binary output	Corresponds to the ext. supply voltage U_H - 0.7 V (X0)
Output current binary output	30 mA ... 0.5 A per channel (electronically limited)
Notes	When auxiliary power is not connected: 6 V / 2 mA
Ambient Conditions	
Ambient temperature °F	-40°F ... +167°F
Ambient temperature °C	-40°C ... +75°C
Mechanical Data	
Degree of protection IP (IEC 60529)	IP20

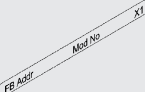
06 b

Accessories			Art. No.	Weight lb
Figure	Description			
Plug-in terminal				
	1.5 mm ² with lock, 24-pole, spring clamp connection, black for connecting the field signals to I/O modules, for non-intrinsically safe field circuits Caution: only for 9469, 9471 and 9472 I/O modules Labelling: 1 ... 24		245090 ▲	-
	1.5 mm ² with lock, 24-pole, spring clamp connection, black for connecting the field signals to I/O modules, for non-intrinsically safe field circuits Caution: only for 9469, 9471 and 9472 I/O modules Labelling: 25 ... 48		245091 ▲	-
Resistor error message suppression				
	The resistors are used to suppress error messages for unused I/O channels Resistance value: 5K6 / 0.5 W Suitable for: AIM 9468; DIOM 9470; DIOM 9471; DIOM 9472; DOM 9475 For intrinsically safe circuits (simple apparatus according to EN 60079-11)		244911	-
Labelling strips				
	"FB Addr ... Mod No ..." for pluggable terminal, 26 pieces on the sheet		162788	-
DIN A4 sheet				
	For the label plate on I/O modules, 6 labels per sheet Print IS Wizard, packaging unit = 20 sheets		162832	-
Partition				
	For mounting between intrinsically safe and non-intrinsically safe connections of the I/O modules, in order to adhere to the required 50 mm distance		220101 ▲	0.02

Accessories			
Figure	Description	Art. No.	Weight lb
Warning sign			
	"Clean modules only with a damp cloth."	162796	-

Technical Drawings – Subject to Alterations

06 b

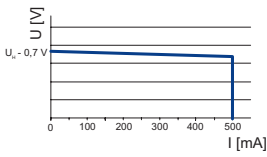

Connection diagram

Dimensional Drawings (All Dimensions in mm [inches]) – Subject to Alterations

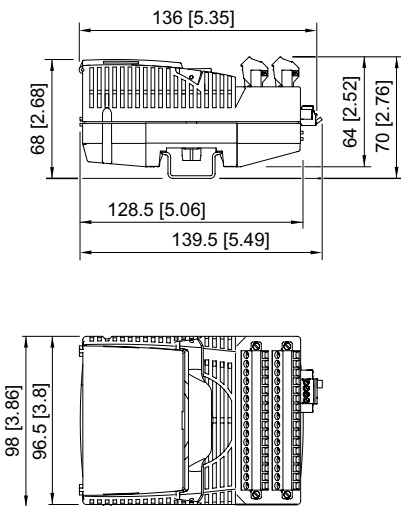



- Four channels for Ex i solenoid valves up to 40 mA
- Ex ia outputs with line fault monitoring and LED error and status indication for each channel plus SIL 2 shutdown input
- Modules in Zone 1, Cl. I, II, Div. 1 can be hot swapped

WebCode 9475E



06 b

9475/32-04 series digital output modules for Zone 1, Cl. I, II, Div. 1 have four channels for actuating Ex i solenoid valves or indicator lamps. An additional Ex i control input is suitable for safe shutdown up to SIL 2. All outputs are short-circuit proof, galvanically separated from the system and individually monitored to check for wire breakage/short-circuiting.

	NEC® 500 CEC Appendix J					
	Class I		Class II		Class III	
Division	1	2	1	2	1	2
Ex interface	•	•	•	•	•	•
Installation in	•	•	•	•	•	•

	CEC Section 18 NEC® 505 NEC® 506					
	Class I					
Zone	0	1	2	20	21	22
Ex interface	•	•	•	•	•	•
Installation in		•	•		•	•





	IECEx / ATEX					
	Zone	0	1	2	20	21
Ex interface	•	•	•	•	•	•
Installation in		•	•		•	•

Selection Table						
Product variant	Digital output module with "Plant STOP"					
Installation	Zone 1, Zone 2, Zone 21, Zone 22, Cl. I, II, Div. 1, 2 and in the safe area					
Open-circuit voltage U _o	Ex i output rated operation	Internal resistance of outputs	Product Type	Art. No.	Weight lb	
17.9 V	11.3 V/40 mA	170 Ω	9475/32-04-12	210651	0.61	
23.6 V	12.3 V/40 mA	287 Ω	9475/32-04-22	210652 ▲	0.61	
Please order terminals separately - see accessories and spare parts						

Technical Data		
Variant	9475/32-04-12	9475/32-04-22
Explosion Protection		
USA certificate FM	FM17US0332X	FM17US0332X
CAN certificate FM	FM16CA0134X	FM16CA0134X
USA marking FM	IS; Class I,II,III, Div. 1, Groups A,B,C,D,E,F,G; AIS; Class I,II,III, Div. 1, Groups A,B,C,D,E,F,G; Class I, Zone 1, AEx ia [ia] IIC; T4 at Ta = 75 °C; See Doc. 9475 6 031 001 1	IS; Class I,II,III, Div. 1, Groups A,B,C,D,E,F,G; AIS; Class I,II,III, Div. 1, Groups A,B,C,D,E,F,G; Class I, Zone 1, AEx ia [ia] IIC; T4 at Ta = 75 °C; See Doc. 9475 6 031 001 1
CAN marking FM	IS; Class I,II,III, Div. 1, Groups A,B,C,D,E,F,G; AIS; Class I,II,III, Div. 1, Groups A,B,C,D,E,F,G; Class I, Zone 1, Ex ia [ia] IIC; T4 at Ta = 75 °C; See Doc. 9475 6 031 001 1	IS; Class I,II,III, Div. 1, Groups A,B,C,D,E,F,G; AIS; Class I,II,III, Div. 1, Groups A,B,C,D,E,F,G; Class I, Zone 1, Ex ia [ia] IIC; T4 at Ta = 75 °C; See Doc. 9475 6 031 001 1
IECEx gas explosion protection	Ex ia [ia Ga] IIC T4 Gb	Ex ia [ia Ga] IIC T4 Gb
IECEx dust explosion protection	[Ex ia Da] IIC	[Ex ia Da] IIC

06 b

Technical Data		
Variant	9475/32-04-12	9475/32-04-22
Explosion Protection		
Certificates	ATEX (DEK), Brazil (ULB), Canada (FM), EAC (STV), IECEx (DEK), India (PESO), Korea (KTL), SIL (exida), USA (FM)	ATEX (DEK), Brazil (ULB), Canada (FM), EAC (STV), IECEx (DEK), India (PESO), Korea (KTL), SIL (exida), USA (FM)
Ship approval	ABS, CCS, ClassNK, DNV GL, RINA	ABS, CCS, ClassNK, DNV GL, RINA
Safety Data		
Max. voltage U_j/V_{oc}	19.7 V	25.7 V
Max. current I_o (Ex ia)	142 mA	110 mA
Max. current I_o (Ex ib)	53.8 mA	49.5 mA
Max. power P_o (Ex ia)	698 mW	708 mW
Max. power P_o (Ex ib)	617 mW	648 mW
Electrical Data		
Number of channels	4 Ex i outputs	4 Ex i outputs
Auxiliary Power		
Current consumption	210 mA	240 mA
Max. power consumption	5 W	5.8 W
Max. power dissipation outputs	4 W	4.5 W
Input		
Control input	Ex i control input X3	Ex i control input X3
Control input suitability	Switch-off up to SIL 2, low demand (IEC61508)	Switch-off up to SIL 2, low demand (IEC61508)
Control input function	"Plant STOP" to switch off all outputs	"Plant STOP" to switch off all outputs
Ambient Conditions		
Ambient temperature °F	-40°F ... +167°F	-40°F ... +167°F
Ambient temperature °C	-40°C ... +75°C	-40°C ... +75°C
Mechanical Data		
Degree of protection IP (IEC 60529)	IP20	IP20

Accessories				
Figure	Description	Product Type	Art. No.	Weight lb
Pluggable terminal				
	2.5 mm ² with lock, 16-pole, screw connector, blue, for connecting the field signals to I/O modules, for intrinsically safe field circuits Labelling: 1 ... 16 Attention: An additional terminal is necessary for I/O module Series 9470 and 9482. Labelling: 17 ... 32	-	162702	0.06
	2.5 mm ² with lock, 16-pole, spring clamp connection, blue, for connecting the field signals to I/O modules, for intrinsically safe field circuits, incl. test jacks Labelling: 1 ... 16 Attention: An additional terminal is necessary for I/O module Series 9470 and 9482. Labelling: 17 ... 32	-	162695 ▲	0.06
Electronic relay				
	The electronic relay module 9174 is used to switch Ex e loads by using intrinsically safe control signals. Input: Ex i Output: 48 V / 2 A DC, Ex e	9174/10-14-00	212340 ▲	0.24
	The electronic relay module 9174 is used to switch Ex e loads by using intrinsically safe control signals. Input: Ex i Output: 250 V / 1 A DC, Ex e	9174/10-15-00	212431	0.24
LED Indicator lamp Ex i				
	LED indicator lamp for intrinsically safe circuits 8010/3-02, Ex i	8010/3-02	237972	0.08

Accessories				
Figure	Description	Product Type	Art. No.	Weight lb
Labelling strips				
	"FB Addr ... Mod No ..." for pluggable terminal, 26 pieces on the sheet	-	162788	-
DIN A4 sheet				
	For the label plate on I/O modules, 6 labels per sheet Print IS Wizard, packaging unit = 20 sheets	-	162832	-
Partition				
	For mounting between intrinsically safe and non-intrinsically safe connections of the I/O modules, in order to adhere to the required 50 mm distance	-	220101 ▲	0.02
Warning sign				
	"Clean modules only with a damp cloth."	-	162796	-
Resistor error message suppression				
	The resistors are used to suppress error messages for unused I/O channels Resistance value: 5K6 / 0.5 W Suitable for: AIM 9468; DIOM 9470; DIOM 9471; DIOM 9472; DOM 9475 For intrinsically safe circuits (simple apparatus according to EN 60079-11)	-	244911	-

06 b

Technical Drawings – Subject to Alterations

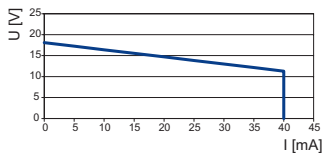

Output characteristic 9475/32-04-12

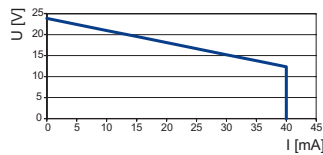

Output characteristic 9475/32-04-22

Dimensional Drawings (All Dimensions in mm [inches]) – Subject to Alterations

06 b

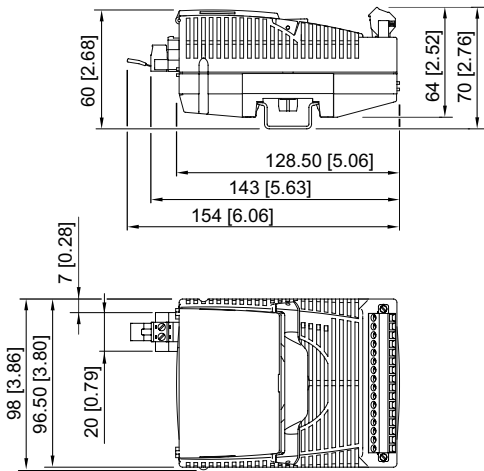



- Four channels for Ex i hydraulic and solenoid valves up to 95 mA
- Ex ib outputs with line fault monitoring and LED error and status indication for each channel plus SIL 2 shutdown input
- Modules in Zone 1, Cl. I, II, Div. 2 can be hot swapped

WebCode 9475F



06 b

9475/32-04-72 series digital output modules for Zone 1, Cl. I, II, Div. 2 have four channels for actuating Ex i hydraulic and solenoid valves or indicator lamps. An additional Ex i control input is suitable for safe shutdown up to SIL 2. All outputs are short-circuit proof, galvanically separated from the system and individually monitored to check for wire breakage/short-circuiting.

	NEC® 500 CEC Appendix J					
	Class I		Class II		Class III	
Division	1	2	1	2	1	2
Ex interface		•		•		•
Installation in		•		•		•

	CEC Section 18 NEC® 505 NEC® 506					
	Class I					
Zone	0	1	2	20	21	22
Ex interface		•	•		•	•
Installation in		•	•		•	•



	IECEX / ATEX					
	Zone	0	1	2	20	21
Ex interface		•	•		•	•
Installation in		•	•		•	•



Selection Table						
Product variant	Digital output module with "Plant STOP"					
Installation	Zone 1, Zone 2, Zone 21, Zone 22, Cl. I, II, Div. 2 and in the safe area					
Open-circuit voltage U _o	Ex i output rated operation	Internal resistance of outputs	Product Type	Art. No.	Weight lb	
13.8 V	12.3 V/75 mA 11.7 V/95 mA	23.2 Ω	9475/32-04-72	218063	0.61	
Please order terminals separately - see accessories and spare parts						

Technical Data	
Explosion Protection	
USA certificate FM	FM17US0332X
CAN certificate FM	FM16CA0134X
USA marking FM	IS; Class I,II,III, Div. 2, Groups A,B,C,D,E,F,G; NIFW; Class I,II,III, Div. 2, Groups A,B,C,D,E,F,G; Class I, Zone 1, AEx ia [ib] IIC; T4 at Ta = 75 °C; See Doc. 9475 6 031 005 1
CAN marking FM	IS; Class I,II,III, Div. 2, Groups A,B,C,D,E,F,G; NIFW; Class I,II,III, Div. 2, Groups A,B,C,D,E,F,G; Class I, Zone 1, Ex ia [ib] IIC; T4 at Ta = 75 °C; See Doc. 9475 6 031 005 1
IECEX gas explosion protection	Ex ia [ib Gb] IIC T4 Gb
IECEX dust explosion protection	[Ex ib Db] IIIC
Certificates	ATEX (DEK), Brazil (ULB), Canada (FM), EAC (STV), IECEX (DEK), India (PESO), Korea (KTL), SIL (exida), USA (FM)
Ship approval	ABS, CCS, ClassNK, DNV GL, RINA

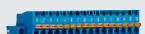
06 b

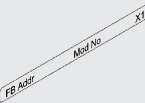
Technical Data	
Safety Data	
Max. voltage U_i/V_{oc}	15.4 V
Max. current I_o (Ex ib)	115.4 mA
Max. power P_o (Ex ib)	1475 mW
Auxiliary Power	
Current consumption	250 mA
Max. power consumption	6 W
Max. power dissipation outputs	5.8 W
Input	
Control input	Ex i control input X3
Control input suitability	Switch-off up to SIL 2, low demand (IEC61508)
Control input function	"Plant STOP" to switch off all outputs
Output	
Ex i output rated operation	12.3 V/75 mA 11.7 V/95 mA
Ambient Conditions	
Ambient temperature °F	-40°F ... +167°F
Ambient temperature °C	-40°C ... +75°C
Mechanical Data	
Degree of protection IP (IEC 60529)	IP20

Accessories				
Figure	Description	Product Type	Art. No.	Weight lb
Pluggable terminal				
	2.5 mm ² with lock, 16-pole, screw connector, blue, for connecting the field signals to I/O modules, for intrinsically safe field circuits Labelling: 1 ... 16 Attention: An additional terminal is necessary for I/O module Series 9470 and 9482. Labelling: 17 ... 32	-	162702	0.06
	2.5 mm ² with lock, 16-pole, spring clamp connection, blue, for connecting the field signals to I/O modules, for intrinsically safe field circuits, incl. test jacks Labelling: 1 ... 16 Attention: An additional terminal is necessary for I/O module Series 9470 and 9482. Labelling: 17 ... 32	-	162695 ▲	0.06
Electronic relay				
	The electronic relay module 9174 is used to switch Ex e loads by using intrinsically safe control signals. Input: Ex i Output: 48 V / 2 A DC, Ex e	9174/10-14-00	212340 ▲	0.24
	The electronic relay module 9174 is used to switch Ex e loads by using intrinsically safe control signals. Input: Ex i Output: 250 V / 1 A DC, Ex e	9174/10-15-00	212431	0.24
LED Indicator lamp Ex i				
	LED indicator lamp for intrinsically safe circuits 8010/3-02, Ex i	8010/3-02	237972	0.08
Labelling strips				
	"FB Addr ... Mod No ..." for pluggable terminal, 26 pieces on the sheet	-	162788	-

Accessories				
Figure	Description	Product Type	Art. No.	Weight lb
DIN A4 sheet				
	For the label plate on I/O modules, 6 labels per sheet Print IS Wizard, packaging unit = 20 sheets	-	162832	-
Partition				
	For mounting between intrinsically safe and non-intrinsically safe connections of the I/O modules, in order to adhere to the required 50 mm distance	-	220101 ▲	0.02
Warning sign				
	"Clean modules only with a damp cloth."	-	162796	-

06 b

Technical Drawings – Subject to Alterations

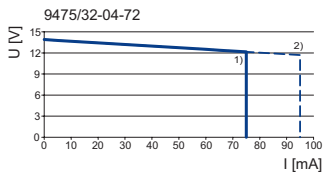

- ¹⁾ 4 channels
- ²⁾ max. 3 channels

Output characteristic 9475/32-04-72

Dimensional Drawings (All Dimensions in mm [inches]) – Subject to Alterations

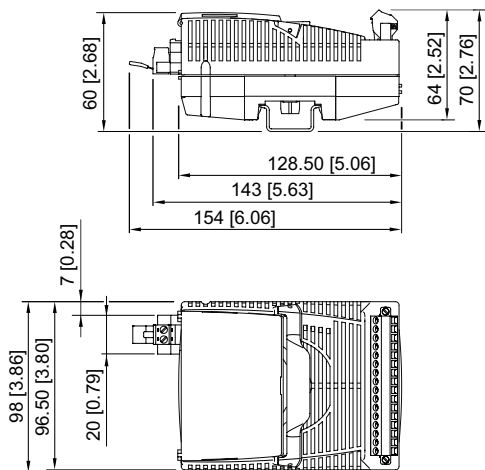



- Eight channels for Ex i solenoid valves up to 30 mA
- Ex ia outputs with line fault monitoring and LED error and status indication for each channel plus SIL 2 shutdown input
- Modules in Zone 1, Cl. I, II, Div. 1 can be hot swapped

06 b

WebCode 9475C



9475/32-08 series digital output modules for Zone 1, Cl. I, II, Div. 1 have eight channels for actuating Ex i solenoid valves or indicator lamps. An additional Ex i control input is suitable for safe shutdown up to SIL 2. All outputs are short-circuit proof, galvanically separated from the system and individually monitored to check for wire breakage/short-circuiting.

	NEC® 500 CEC Appendix J						CEC Section 18						IECEX / ATEX					
	Class I		Class II		Class III		NEC® 505 Class I			NEC® 506			Zone 0		Zone 1		Zone 2	
Division	1	2	1	2	1	2	0	1	2	20	21	22	0	1	2	20	21	22
Ex interface	•	•	•	•	•	•	•	•	•	•	•	•	•	•	•	•	•	•
Installation in	•	•	•	•	•	•	•	•	•	•	•	•	•	•	•	•	•	

Selection Table						
Product variant	Digital output module with "Plant STOP"					
Installation	Zone 1, Zone 2, Zone 21, Zone 22, Cl. I, II, Div. 1, 2 and in the safe area					
Open-circuit voltage U _o	Ex i output rated operation	Internal resistance of outputs	Product Type	Art. No.	Weight lb	
17.5 V	12.6 V/30 mA	170 Ω	9475/32-08-52	210655 ▲	0.61	
23.5 V	17.5 V/20 mA	315 Ω	9475/32-08-62	210656 ▲	0.61	

Please order terminals separately - see accessories and spare parts

Technical Data		
Variant	9475/32-08-52	9475/32-08-62
Explosion Protection		
USA certificate FM	FM17US0332X	FM17US0332X
CAN certificate FM	FM16CA0134X	FM16CA0134X
USA marking FM	IS; Class I,II,III, Div. 1, Groups A,B,C,D,E,F,G; AIS; Class I,II,III, Div. 1, Groups A,B,C,D,E,F,G; Class I, Zone 1, AEx ia [ia] IIC; T4 at Ta = 75 °C; See Doc. 9475 6 031 002 1	IS; Class I,II,III, Div. 1, Groups A,B,C,D,E,F,G; AIS; Class I,II,III, Div. 1, Groups A,B,C,D,E,F,G; Class I, Zone 1, AEx ia [ia] IIC; T4 at Ta = 75 °C; See Doc. 9475 6 031 002 1
CAN marking FM	IS; Class I,II,III, Div. 1, Groups A,B,C,D,E,F,G; AIS; Class I,II,III, Div. 1, Groups A,B,C,D,E,F,G; Class I, Zone 1, Ex ia [ia] IIC; T4 at Ta = 75 °C; See Doc. 9475 6 031 002 1	IS; Class I,II,III, Div. 1, Groups A,B,C,D,E,F,G; AIS; Class I,II,III, Div. 1, Groups A,B,C,D,E,F,G; Class I, Zone 1, Ex ia [ia] IIC; T4 at Ta = 75 °C; See Doc. 9475 6 031 002 1
IECEX gas explosion protection	Ex ia [ia Ga] IIC T4 Gb	Ex ia [ia Ga] IIC T4 Gb
IECEX dust explosion protection	[Ex ia Da] IIC	[Ex ia Da] IIC

Technical Data		
Variant	9475/32-08-52	9475/32-08-62
Explosion Protection		
Certificates	ATEX (DEK), Brazil (ULB), Canada (FM), EAC (STV), IECEx (DEK), India (PESO), Korea (KTL), SIL (exida), USA (FM)	ATEX (DEK), Brazil (ULB), Canada (FM), EAC (STV), IECEx (DEK), India (PESO), Korea (KTL), SIL (exida), USA (FM)
Ship approval	ABS, CCS, ClassNK, DNV GL, RINA	ABS, CCS, ClassNK, DNV GL, RINA
Safety Data		
Max. voltage $U_{j/V_{oc}}$	19.4 V	25.7 V
Max. current I_o (Ex ia)	143 mA	107 mA
Max. current I_o (Ex ib)	37.8 mA	26.3 mA
Max. power P_o (Ex ia)	692 mW	688 mW
Max. power P_o (Ex ib)	506 mW	468 mW
Electrical Data		
Number of channels	8 Ex i outputs	8 Ex i outputs
Auxiliary Power		
Current consumption	250 mA	240 mA
Max. power consumption	6 W	5.8 W
Max. power dissipation outputs	4.8 W	4 W
Input		
Control input	Ex i control input X3	Ex i control input X3
Control input suitability	Switch-off up to SIL 2, low demand (IEC61508)	Switch-off up to SIL 2, low demand (IEC61508)
Control input function	"Plant STOP" to switch off all outputs	"Plant STOP" to switch off all outputs
Ambient Conditions		
Ambient temperature °F	-40°F ... +167°F	-40°F ... +167°F
Ambient temperature °C	-40°C ... +75°C	-40°C ... +75°C
Mechanical Data		
Degree of protection IP (IEC 60529)	IP20	IP20

06 b

Accessories				
Figure	Description	Product Type	Art. No.	Weight lb
Pluggable terminal				
	2.5 mm ² with lock, 16-pole, screw connector, blue, for connecting the field signals to I/O modules, for intrinsically safe field circuits Labelling: 1 ... 16 Attention: An additional terminal is necessary for I/O module Series 9470 and 9482. Labelling: 17 ... 32	-	162702	0.06
	2.5 mm ² with lock, 16-pole, spring clamp connection, blue, for connecting the field signals to I/O modules, for intrinsically safe field circuits, incl. test jacks Labelling: 1 ... 16 Attention: An additional terminal is necessary for I/O module Series 9470 and 9482. Labelling: 17 ... 32	-	162695 ▲	0.06
Electronic relay				
	The electronic relay module 9174 is used to switch Ex e loads by using intrinsically safe control signals. Input: Ex i Output: 48 V / 2 A DC, Ex e	9174/10-14-00	212340 ▲	0.24
LED Indicator lamp Ex i				
	LED indicator lamp for intrinsically safe circuits 8010/3-02, Ex i	8010/3-02	237972	0.08

06 b

Accessories				
Figure	Description	Product Type	Art. No.	Weight lb
Labelling strips				
	"FB Addr ... Mod No ..." for pluggable terminal, 26 pieces on the sheet	-	162788	-
DIN A4 sheet				
	For the label plate on I/O modules, 6 labels per sheet Print IS Wizard, packaging unit = 20 sheets	-	162832	-
Partition				
	For mounting between intrinsically safe and non-intrinsically safe connections of the I/O modules, in order to adhere to the required 50 mm distance	-	220101 ▲	0.02
Warning sign				
	"Clean modules only with a damp cloth."	-	162796	-
Resistor error message suppression				
	The resistors are used to suppress error messages for unused I/O channels Resistance value: 5K6 / 0.5 W Suitable for: AIM 9468; DIOM 9470; DIOM 9471; DIOM 9472; DOM 9475 For intrinsically safe circuits (simple apparatus according to EN 60079-11)	-	244911	-

Technical Drawings – Subject to Alterations

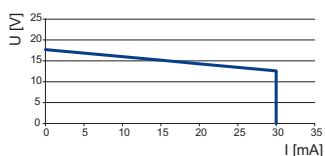

Output characteristic 9475/33-08-50

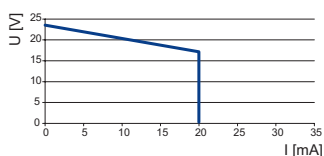

Output characteristic 9475/33-08-60

Digital Output Module 8-Channel Version

Series 9475/32-08 for Zone 1 / Cl. I, II, Div. 1 - I.S.



Dimensional Drawings (All Dimensions in mm [inches]) – Subject to Alterations

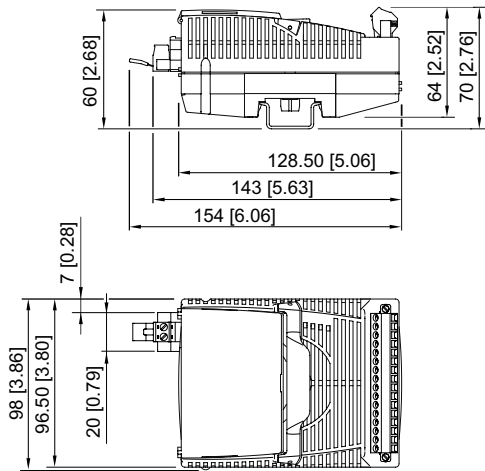

06 b



- Eight channels for Ex i solenoid valves up to 30 mA
- Ex ia outputs with line fault monitoring
- Modules in Zone 2, Cl. I, II, Div. 2 can be hot swapped

06 b

WebCode 9475D



9475/33-08 series digital output modules for Zone 2, Cl. I, II, Div. 2 have eight channels for actuating Ex i solenoid valves or indicator lamps. All outputs are short-circuit proof, galvanically separated from the system and individually monitored to check for wire breakage/short-circuiting.

	NEC® 500 CEC Appendix J						CEC Section 18						IECEX / ATEX					
	Class I		Class II		Class III		NEC® 505 Class I			NEC® 506			Zone 0		Zone 1		Zone 2	
Division	1	2	1	2	1	2	0	1	2	20	21	22	0	1	2	20	21	22
Ex interface	•	•	•	•	•	•	•	•	•	•	•	•	•	•	•	•	•	•
Installation in		•		•		•			•			•			•			•

Selection Table					
Installation					
Zone 2, Zone 22, Cl. I, II, Div. 2 and in the safe area					
Open-circuit voltage U _o	Ex i output rated operation	Internal resistance of outputs	Product Type	Art. No.	Weight lb
17.5 V	12.6 V/30 mA	170 Ω	9475/33-08-50	210657	0.61
23.5 V	17.5 V/20 mA	315 Ω	9475/33-08-60	210658	0.61
Please order terminals separately - see accessories and spare parts					



Technical Data		
Variant	9475/33-08-50	9475/33-08-60
Explosion Protection		
USA certificate FM	FM17US0332X	FM17US0332X
CAN certificate FM	FM16CA0134X	FM16CA0134X
USA marking FM	NI, Class I,II,III, Div. 2, Groups A,B,C,D,E,F,G; AIS, Class I,II,III, Div. 1, Groups A,B,C,D,E,F,G; Class I, Zone 2, AEx nA ia [ia] IIC; T4 at Ta = 75 °C; See Doc. 9475 6 031 004 1	NI, Class I,II,III, Div. 2, Groups A,B,C,D,E,F,G; AIS, Class I,II,III, Div. 1, Groups A,B,C,D,E,F,G; Class I, Zone 2, AEx nA ia [ia] IIC; T4 at Ta = 75 °C; See Doc. 9475 6 031 004 1
CAN marking FM	NI, Class I,II,III, Div. 2, Groups A,B,C,D,E,F,G; AIS, Class I,II,III, Div. 1, Groups A,B,C,D,E,F,G; Class I, Zone 2, Ex nA ia [ia] IIC; T4 at Ta = 75 °C; See Doc. 9475 6 031 004 1	NI, Class I,II,III, Div. 2, Groups A,B,C,D,E,F,G; AIS, Class I,II,III, Div. 1, Groups A,B,C,D,E,F,G; Class I, Zone 2, Ex nA ia [ia] IIC; T4 at Ta = 75 °C; See Doc. 9475 6 031 004 1
IECEX gas explosion protection	Ex nA ia [ia Ga] IIC T4 Gc	Ex nA ia [ia Ga] IIC T4 Gc
IECEX dust explosion protection	[Ex ia Da] IIIC	[Ex ia Da] IIIC
Certificates	ATEX (DEK), Brazil (ULB), Canada (FM), EAC (STV), IECEX (DEK), India (PESO), Korea (KTL), SIL (exida), USA (FM)	ATEX (DEK), Brazil (ULB), Canada (FM), EAC (STV), IECEX (DEK), India (PESO), Korea (KTL), SIL (exida), USA (FM)
Ship approval	ABS, CCS, ClassNK, DNV GL, RINA	ABS, CCS, ClassNK, DNV GL, RINA

Technical Data		
Variant	9475/33-08-50	9475/33-08-60
Safety Data		
Max. voltage U_o/V_{oc}	19.4 V	25.7 V
Max. current I_o (Ex ia)	143 mA	107 mA
Max. current I_o (Ex ib)	37.8 mA	26.3 mA
Max. power P_o (Ex ia)	692 mW	688 mW
Max. power P_o (Ex ib)	506 mW	468 mW
Electrical Data		
Number of channels	8 Ex i outputs	8 Ex i outputs
Auxiliary Power		
Current consumption	250 mA	240 mA
Max. power consumption	6 W	5.8 W
Max. power dissipation outputs	4.8 W	4 W
Ambient Conditions		
Ambient temperature °F	-40°F ... +167°F	-40°F ... +167°F
Ambient temperature °C	-40°C ... +75°C	-40°C ... +75°C
Mechanical Data		
Degree of protection IP (IEC 60529)	IP20	IP20

06 b

Accessories				
Figure	Description	Product Type	Art. No.	Weight lb
Pluggable terminal				
	2.5 mm ² with lock, 16-pole, screw connector, blue, for connecting the field signals to I/O modules, for intrinsically safe field circuits Labelling: 1 ... 16 Attention: An additional terminal is necessary for I/O module Series 9470 and 9482. Labelling: 17 ... 32	-	162702	0.06
	2.5 mm ² with lock, 16-pole, spring clamp connection, blue, for connecting the field signals to I/O modules, for intrinsically safe field circuits, incl. test jacks Labelling: 1 ... 16 Attention: An additional terminal is necessary for I/O module Series 9470 and 9482. Labelling: 17 ... 32	-	162695 ▲	0.06
Electronic relay				
	The electronic relay module 9174 is used to switch Ex e loads by using intrinsically safe control signals. Input: Ex i Output: 48 V / 2 A DC, Ex e	9174/10-14-00	212340 ▲	0.24
LED Indicator lamp Ex i				
	LED indicator lamp for intrinsically safe circuits 8010/3-02, Ex i	8010/3-02	237972	0.08
Labelling strips				
	"FB Addr ... Mod No ..." for pluggable terminal, 26 pieces on the sheet	-	162788	-
DIN A4 sheet				
	For the label plate on I/O modules, 6 labels per sheet Print IS Wizard, packaging unit = 20 sheets	-	162832	-

06 b

Accessories				
Figure	Description	Product Type	Art. No.	Weight lb
Partition				
	For mounting between intrinsically safe and non-intrinsically safe connections of the I/O modules, in order to adhere to the required 50 mm distance	-	220101 ▲	0.02
Warning sign				
	"Clean modules only with a damp cloth."	-	162796	-
Resistor error message suppression				
	The resistors are used to suppress error messages for unused I/O channels Resistance value: 5K6 / 0.5 W Suitable for: AIM 9468; DIOM 9470; DIOM 9471; DIOM 9472; DOM 9475 For intrinsically safe circuits (simple apparatus according to EN 60079-11)	-	244911	-

Technical Drawings – Subject to Alterations

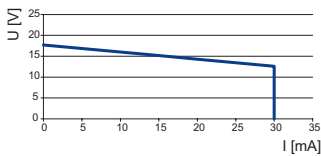

Output characteristic 9475/33-08-50

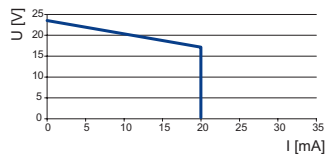

Output characteristic 9475/33-08-60

Dimensional Drawings (All Dimensions in mm [inches]) – Subject to Alterations

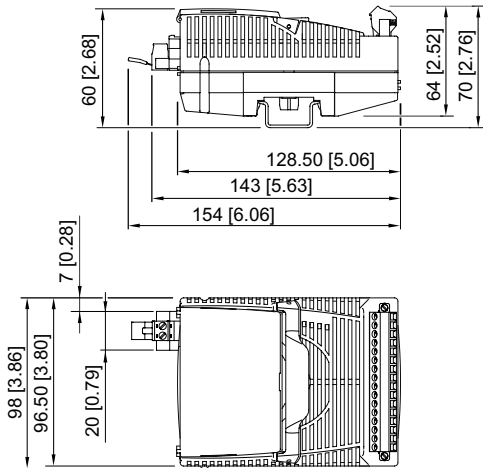



- With up to 8 de-energized relay contacts
- Non-I.S. outputs with a high switching capacity up to 100 VA
- Module in Zone 1, Cl. I, Div. 1 can be hot swapped

WebCode **9477A**



06 b

9477/12 series digital output module relays for Zone 1, Cl. I, Div. 1 have six or eight channels for operating non-intrinsically safe solenoid valves with a high switching capacity. Zero-potential relay contacts (normally open contacts) are available as outputs in Ex e or conduit connection technology. Operation in combination with Ex i I/O modules is permissible.

	NEC® 500 CEC Appendix J					
	Class I		Class II		Class III	
Division	1	2	1	2	1	2
Ex interface	•	•				
Installation in	•	•				

	CEC Section 18					
	NEC® 505			NEC® 506		
	Class I					
Zone	0	1	2	20	21	22
Ex interface		•	•			
Installation in		•	•			

	IECEX / ATEX					
Zone	0	1	2	20	21	22
Ex interface		•	•			
Installation in		•	•			

Selection Table						
Installation Zone 1 / Cl. I, Div. 1						
Number of channels	Max. switching voltage	Max. switching current	Product Type	Art. No.	Weight lb	
6 Ex e outputs	250 V AC	2 A	9477/12-06-12	162630	5.66	
8 Ex e outputs	60 V AC	2 A	9477/12-08-12	162627	5.67	

Please order sockets separately - see accessories

Technical Data		
Variant	6 Ex e outputs	8 Ex e outputs
Explosion Protection		
USA certificate FM	FM17US0332X	FM17US0332X
CAN certificate FM	FM16CA0134X	FM16CA0134X
USA marking FM	XP; Class I, Div. 1, Groups A,B,C,D; Class I, Zone 1, IIC; T4 at Ta = 65 °C; See Doc. 9477 6 031 001 1	XP; Class I, Div. 1, Groups A,B,C,D; Class I, Zone 1, IIC; T4 at Ta = 65 °C; See Doc. 9477 6 031 001 1
CAN marking FM	XP; Class I, Div. 1, Groups A,B,C,D; Class I, Zone 1 per CEC 18-100 T4 at Ta = 65 °C; See Doc. 9477 6 031 001 1	XP; Class I, Div. 1, Groups A,B,C,D; Class I, Zone 1 per CEC 18-100 T4 at Ta = 65 °C; See Doc. 9477 6 031 001 1
IECEX gas explosion protection	Ex d e [ia, ib] IIC T4	Ex d e [ia, ib] IIC T4
Certificates	ATEX (PTB), Canada (CSA), Canada (FM), EAC (STV), IECEX (PTB), USA (FM)	ATEX (PTB), Canada (CSA), Canada (FM), EAC (STV), IECEX (PTB), USA (FM)
Ship approval	ABS, CCS, ClassNK, DNV GL, RINA	ABS, CCS, ClassNK, DNV GL, RINA

Technical Data

Variant	6 Ex e outputs	8 Ex e outputs
Auxiliary Power		
Behaviour during undervoltage	All outputs "OFF"	All outputs "OFF"
Current consumption	200 mA	200 mA
Max. power consumption	3.6 W	4.8 W
Max. power dissipation outputs	3.6 W	4.8 W
Output		
Contact version	NO	NO
Min. switching voltage	5 V AC / DC	5 V AC / DC
Min. switching current	2 mA	2 mA
Max. switching voltage 60 V AC	2 A / 100 VA	2 A / 100 VA
Max. switching voltage 250 V AC	2 A / 100 W	
Max. switching voltage 30 V DC	2 A / 60 W	2 A / 60 W
Max. switching voltage 110 V DC	0.3 A / 33 W	
Max. switching voltage 220 V DC	0.12 A / 26 W	
Ambient Conditions		
Ambient temperature °F	-4°F ... +149°F	-4°F ... +149°F
Ambient temperature °C	-20°C ... +65°C	-20°C ... +65°C
Storage temperature °F	-40°F ... +158°F	-40°F ... +158°F
Storage temperature °C	-40°C ... +70°C	-40°C ... +70°C

Sockets and accessories for Div. 1 installation on request

Accessories and spare parts on the Internet r-stahl.com

Dimensional Drawings (All Dimensions in mm [inches]) – Subject to Alterations

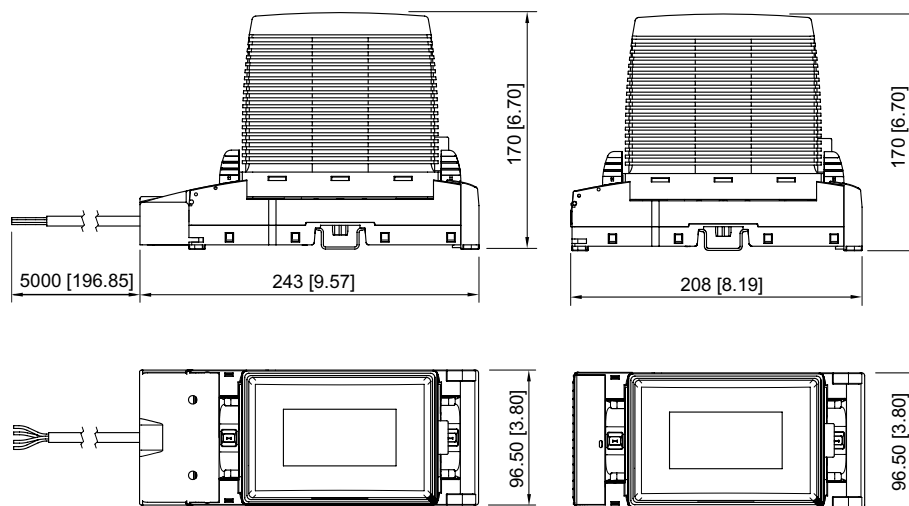

Digital output model relay with base for Division 1

Digital output module relay for Zone 1



- With 8 zero-potential relay contacts
- Ex ec/nA outputs with a high switching capacity up to 100 VA
- Module in Zone 2, Cl. I, Div. 2 can be hot swapped

WebCode 9477B



06 b

The 9477/15 series digital output module relay for Zone 2, Cl. I, Div. 2 has eight channels for operating non-intrinsically safe solenoid valves with a high switching capacity. Zero-potential relay contacts (normally open contacts) are available as outputs in Ex ec/nA connection technology. Operation in combination with Ex i I/O modules is permissible.

	NEC® 500 CEC Appendix J					
	Class I		Class II		Class III	
Division	1	2	1	2	1	2
Ex interface		•				
Installation in		•				

	CEC Section 18					
	NEC® 505 Class I			NEC® 506		
Zone	0	1	2	20	21	22
Ex interface			•			•
Installation in			•			•

	IECEX / ATEX					
	Zone	0	1	2	20	21
Ex interface			•			•
Installation in			•			•





Selection Table						
Installation	Zone 2, Zone 22, Cl I, Div. 2					
Number of channels	Max. switching voltage	Max. switching current	Product Type	Art. No.	Weight lb	
8 Ex nA outputs	250 V AC	2 A	9477/15-08-12	168694	0.71	
Please order terminal separately - see accessories						

Technical Data	
Explosion Protection	
USA certificate FM	FM17US0332X
CAN certificate FM	FM16CA0134X
USA marking FM	NI; Class I, Div. 2, Groups A,B,C,D; Class I, Zone 2, IIC; T4 at Ta = 65 °C; See Doc. 9477 6 031 002 1
CAN marking FM	NI; Class I, Div. 2, Groups A,B,C,D; Class I, Zone 2 per CEC 18-150 T4 at Ta = 65 °C; See Doc. 9477 6 031 002 1
IECEX gas explosion protection	Ex nA nC ic [Ib Gb] IIC T4 Gc
Certificates	ATEX (PTB), Canada (CSA), Canada (FM), EAC (STV), IECEX (PTB), USA (FM)
Ship approval	ABS, CCS, ClassNK, DNV GL, RINA
Auxiliary Power	
Behaviour during undervoltage	All outputs "OFF"
Current consumption	200 mA
Max. power consumption	4.8 W

Technical Data

Auxiliary Power	
Max. power dissipation outputs	4.8 W
Output	
Contact version	NO
Min. switching voltage	5 V AC / DC
Min. switching current	2 mA
Ambient Conditions	
Ambient temperature °F	-4°F ... +149°F
Ambient temperature °C	-20°C ... +65°C
Storage temperature °F	-40°F ... +158°F
Storage temperature °C	-40°C ... +70°C

Accessories

Figure	Description	Art. No.	Weight lb
Pluggable terminal			
	2.5 mm² with screw lock, 16-pole, screw connection, black, for connecting the field signals to I/O modules, for non-intrinsically safe field circuits Version with warning sign Labelling: 1 ... 16	162704 ▲	-
	2.5 mm² with screw lock, 16-pole, spring connection, black, for connecting the field signals to I/O modules, for non-intrinsically safe field circuits including test jacks Version with warning sign Labelling: 1 ... 16	162706 ▲	-
Labelling strips			
	"FB Addr ... Mod No ..." for pluggable terminal, 26 pieces on the sheet	162788	-
DIN A4 sheet			
	For the label plate on I/O modules, 6 labels per sheet Print IS Wizard, packaging unit = 20 sheets	162832	-
Partition			
	For mounting between intrinsically safe and non-intrinsically safe connections of the I/O modules, in order to adhere to the required 50 mm distance	220101 ▲	0.02

Dimensional Drawings (All Dimensions in mm [inches]) – Subject to Alterations

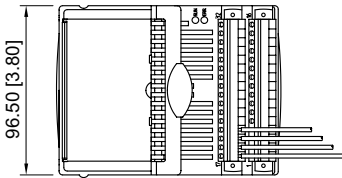
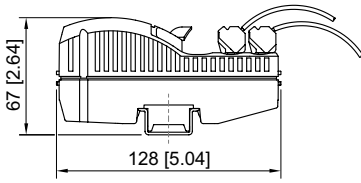

06 b



- 8 channels for pneumatic valves
- Pneumatic outputs with integrated 3/2-way valves and SIL 2 shut-down input
- Module in Zone 1, Cl. I, Div. 1 can be hot swapped

06 b

WebCode 9478A



The 9478 series digital output module valve for Zone 1, Cl. I, Div. 1 has eight channels for actuating pneumatic valves. The integrated 3/2-way solenoid valves are monitored to check for internal wire breakage and short-circuiting regardless of the drive status. An additional Ex i control input is suitable for safe shutdown up to SIL 2. Operation in combination with Ex i I/O modules is permissible.

	NEC® 500 CEC Appendix J					
	Class I		Class II		Class III	
Division	1	2	1	2	1	2
Ex interface						
Installation in	•	•	•	•	•	•

	CEC Section 18					
	NEC® 505 Class I			NEC® 506		
Zone	0	1	2	20	21	22
Ex interface						
Installation in		•	•	•	•	

	IECEX / ATEX					
	Zone	0	1	2	20	21
Ex interface						
Installation in		•	•		•	•

Selection Table					
Product variant	Digital Output Module Valve for Zone 1 / Cl. I, Div. 1				
Number of pneumatic valves	Pressure range min.	Max. pressure range	Product Type	Art. No.	Weight lb
8 x 3/2-valves	2.5 bar	7 bar	9478/22-08-51	203599 ▲	2.09

Technical Data	
Explosion Protection	
USA certificate FM	FM17US0332X
CAN certificate FM	FM16CA0134X
USA marking FM	IS; Class I,II,III, Div. 1, Groups A,B,C,D,E,F,G; AIS; Class I,II,III, Div. 1, Groups A,B,C,D,E,F,G; Class I, Zone 1, [AEx ia] IIC; T4 at Ta = 60 °C; See Doc. 9478 6 031 001 1
CAN marking FM	IS; Class I,II,III, Div. 1, Groups A,B,C,D,E,F,G; AIS; Class I,II,III, Div. 1, Groups A,B,C,D,E,F,G; Class I, Zone 1, [Ex ia] IIC; T4 at Ta = 60 °C; See Doc. 9478 6 031 001 1
IECEX gas explosion protection	Ex ib IIC T4
Certificates	ATEX (PTB), Brazil (ULB), Canada (FM), EAC (STV), IECEX (PTB), Korea (KTL), SIL (exida), USA (FM)
Ship approval	CCS, DNV GL, RINA
Auxiliary Power	
Max. power consumption	5.75 W with activated pilot valves
Undervoltage monitoring	All outputs are depressurized
Input	
Control input suitability	Switch-off up to SIL 2, low demand (IEC61508)

Technical Data

Input	
Control input function	System OFF, outputs are depressurized
Device Specific Data	
Pneumatic data media	Compressed air oiled Dry Neutral gasses (5 µm filter received) Oil-free
Pneumatic data manual actuation	Yes
Pneumatic data switching times	Approx. 1000 c.p.m.
Pneumatic data Qn value	300 l/min
Pneumatic data Qn value note	at 20 °C air temperature, 6 bar at the valve inlet and 1 bar of differential pressure
Pneumatic connections	P, R: plug connector Ø 8 mm Y0 ... Y7: plug connector Ø 6 mm X: standard silencer (included in the delivery and already fitted)
Ambient Conditions	
Ambient temperature °F	32°F ... +140°F
Ambient temperature °C	0°C ... +60°C
Mechanical Data	
Degree of protection IP (IEC 60529)	IP20
Enclosure material	Polyamide 6GF
Sealing material	FPM, NBR
Material of valve block	PPS, PA

06 b

Dimensional Drawings (All Dimensions in mm [inches]) – Subject to Alterations

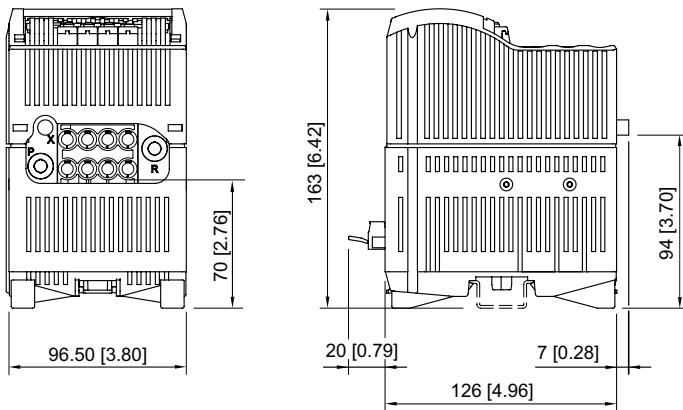



- Eight channels for resistance temperature detectors, potentiometers, thermocouples, mV sensors and joysticks
- Intrinsically safe Ex ia inputs with line fault monitoring and LED error indication
- Module in Zone 1, Cl. I, II, Div. 1 can be hot swapped

06 b

WebCode 9482A









The series 9482 temperature input module for Zone 1, Cl. I, II, Div. 1 has eight channels for the Ex i operation of resistance temperature detectors with two-, three- or four-conductor connection and thermocouples. Sensors that comply with DIN, IEC and GOST are supported as well as resistance transmitters up to 10 kΩ and also joysticks for rapid four-channel operation. Earthed thermocouples can be connected. Cold junction compensation can be performed internally or externally.



	NEC® 500 CEC Appendix J						CEC Section 18 NEC® 505 NEC® 506						IECEX / ATEX					
	Class I		Class II		Class III		Class I			Class I								
Division	1	2	1	2	1	2	0	1	2	20	21	22	0	1	2	20	21	22
Ex interface	•	•	•	•	•	•	•	•	•	•	•	•	•	•	•	•	•	•
Installation in	•	•	•	•	•	•	•	•	•	•	•	•	•	•	•	•		

Selection Table				
Installation	Zones 1, 2, 21, 22, Div. 1, Cl I, II, Div. 2 and in the safe area			
Number of channels	Product Type		Art. No.	Weight lb
8 or 4 Ex i inputs (depends on operating mode)	9482/32-08-11		217643 ▲	0.61
Please order 2 terminals separately - see accessories and spare parts				

Technical Data	
Explosion Protection	
USA certificate FM	FM17US0332X
CAN certificate FM	FM16CA0134X
USA marking FM	IS; Class I,II,III, Div. 1, Groups A,B,C,D,E,F,G; AIS; Class I,II,III, Div. 1, Groups A,B,C,D,E,F,G; Class I, Zone 1, AEx ia [ia] IIC; T4 at Ta = 75 °C; See Doc. 9482 6 031 001 1
CAN marking FM	IS; Class I,II,III, Div. 1, Groups A,B,C,D,E,F,G; AIS; Class I,II,III, Div. 1, Groups A,B,C,D,E,F,G; Class I, Zone 1, Ex ia [ia] IIC; T4 at Ta = 75 °C; See Doc. 9482 6 031 001 1
IECEX gas explosion protection	Ex ia [ia Ga] IIC T4 Gb
IECEX dust explosion protection	[Ex ia Da] IIIC
Certificates	ATEX (DEK), Brazil (ULB), Canada (FM), EAC (STV), IECEX (DEK), India (PESO), Korea (KTL), Russia (Meteorological certificate), USA (FM)
Ship approval	ABS, CCS, ClassNK, DNV GL, RINA

Technical Data	
Safety Data	
Notes	For proof of intrinsic safety, the safety data must be used in accordance with the combination of connections and the corresponding sensor. For further information and combination, see operating instructions.
Auxiliary Power	
Current consumption	42 mA
Max. power consumption	1 W
Max. power dissipation inputs	1 W
Input	
Compensation of reference junctions	Internal (adjustable parameters) External 3-wire circuit
Notes	For a breakdown of the sensors see page 128
Ambient Conditions	
Ambient temperature °F	-40°F ... +167°F
Ambient temperature °C	-40°C ... +75°C
Mechanical Data	
Degree of protection IP (IEC 60529)	IP20
Dimensional drawings see serie 9482/33 page 125	
Connectable sensors see page 128	

Accessories				
Figure	Description	Product Type	Art. No.	Weight lb
External reference junction				
	External reference junction for 2 x thermocouple (1 x Pt100 for 2, 3 or 4 wire connection) integrated into the 4-pole. terminal block. Installation takes place on the DIN rail.	9191/VS-04	160675	0.07
Pluggable terminal				
	2.5 mm ² with lock, 16-pole, screw connector, blue, for connecting the field signals to I/O modules, for intrinsically safe field circuits Labelling: 1 ... 16 Attention: An additional terminal is necessary for I/O module Series 9470 and 9482. Labelling: 17 ... 32	-	162702	0.06
	2.5 mm ² with lock, 16-pole, screw connector, blue for connecting the field signals to I/O modules, for intrinsically safe field circuits Labelling: 17 ... 32	-	162718	0.06
	2.5 mm ² with lock, 16-pole, spring clamp connection, blue, for connecting the field signals to I/O modules, for intrinsically safe field circuits, incl. test jacks Labelling: 1 ... 16 Attention: An additional terminal is necessary for I/O module Series 9470 and 9482. Labelling: 17 ... 32	-	162695 ▲	0.06
	2.5 mm ² with lock, 16-pole, spring clamp connection, blue for connecting the field signals to I/O modules, for intrinsically safe field circuits, incl. test jacks Labelling: 17 ... 32	-	162716 ▲	0.06
Labelling strips				
	"FB Addr ... Mod No ..." for pluggable terminal, 26 pieces on the sheet	-	162788	-
DIN A4 sheet				
	For the label plate on I/O modules, 6 labels per sheet Print IS Wizard, packaging unit = 20 sheets	-	162832	-

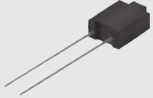
Accessories				
Figure	Description	Product Type	Art. No.	Weight lb
Partition				
	For mounting between intrinsically safe and non-intrinsically safe connections of the I/O modules, in order to adhere to the required 50 mm distance	-	220101 ▲	0.02
Warning sign				
	"Clean modules only with a damp cloth."	-	162796	-
Resistor error message suppression				
	The resistors are used to suppress error messages for unused I/O channels Resistance value: 62R / 0.5 W Suitable for: AOM 9468; TIM 9482	-	244912	-

06 b



- Eight channels for resistance temperature detectors, potentiometers, thermocouples, mV sensors and joysticks
- Intrinsically safe Ex ia inputs with line fault monitoring
- Module in Zone 2, Cl. I, II, Div. 2 can be hot swapped

WebCode 9482B



06 b

The 9482 series temperature input module for Zone 2, Cl. I, II, Div. 2 has eight channels for the Ex i operation of resistance temperature detectors with two-, three- or four-conductor connection and thermocouples. Sensors that comply with DIN, IEC and GOST are supported as well as resistance transmitters up to 10 kΩ and also joysticks for rapid four-channel operation. Earthed thermocouples can be connected. Cold junction compensation can be performed internally or externally.

	NEC® 500 CEC Appendix J					
	Class I		Class II		Class III	
Division	1	2	1	2	1	2
Ex interface	•	•	•	•	•	•
Installation in		•		•		•

	CEC Section 18 NEC® 505 NEC® 506					
	Class I					
Zone	0	1	2	20	21	22
Ex interface	•	•	•	•	•	•
Installation in			•			•

	IECEx / ATEX					
	Zone	0	1	2	20	21
Ex interface	•	•	•	•	•	•
Installation in			•			•

Selection Table					
Installation	Zones 2, 22, Cl I, II, Div. 2 and in the safe area				
Number of channels	Product Type			Art. No.	Weight lb
(depends on operating mode) 8 or 4 Ex i inputs	9482/33-08-10			217644	0.61
Please order 2 terminals separately - see accessories and spare parts					

Technical Data	
Explosion Protection	
USA certificate FM	FM17US0332X
CAN certificate FM	FM16CA0134X
USA marking FM	IS; Class I,II,III, Div. 1, Groups A,B,C,D,E,F,G; AIS; Class I,II,III, Div. 1, Groups A,B,C,D,E,F,G; Class I, Zone 2, AEx ia [ia] IIC; T4 at Ta = 75 °C; See Doc. 9482 6 031 002 1
CAN marking FM	NI, Class I,II,III, Div. 2, Groups A,B,C,D,E,F,G; AIS, Class I,II,III, Div. 1, Groups A,B,C,D,E,F,G; Class I, Zone 2, Ex nA ia [ia] IIC; T4 at Ta = 75 °C; See Doc. 9482 6 031 002 1
IECEx gas explosion protection	Ex nA ia [ia Ga] IIC T4 Gb
IECEx dust explosion protection	[Ex ia Da] IIIC
Certificates	ATEX (DEK), Brazil (ULB), Canada (FM), EAC (STV), IECEx (DEK), India (PESO), Korea (KTL), Russia (Meteorological certificate), USA (FM)
Ship approval	ABS, CCS, ClassNK, DNV GL, RINA

Technical Data

Safety Data

Notes	For proof of intrinsic safety, the safety data must be used in accordance with the combination of connections and the corresponding sensor. For further information and combination, see operating instructions.
-------	---

Auxiliary Power

Current consumption	42 mA
Max. power consumption	1 W
Max. power dissipation inputs	1 W

Input

Compensation of reference junctions	Internal (adjustable parameters) External 3-wire circuit
Notes	For a breakdown of the sensors see page 128

Ambient Conditions







Ambient temperature °F	-40°F ... +167°F
Ambient temperature °C	-40°C ... +75°C



Mechanical Data

Degree of protection IP (IEC 60529)	IP20
-------------------------------------	------

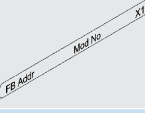
Connectable sensors see page 128

Accessories

Figure	Description	Product Type	Art. No.	Weight lb
External reference junction				
	External reference junction for 2 x thermocouple (1 x Pt100 for 2, 3 or 4 wire connection) integrated into the 4-pole. terminal block. Installation takes place on the DIN rail.	9191/VS-04	160675	0.07
Pluggable terminal				
	2.5 mm² with lock, 16-pole, screw connector, blue, for connecting the field signals to I/O modules, for intrinsically safe field circuits Labelling: 1 ... 16 Attention: An additional terminal is necessary for I/O module Series 9470 and 9482. Labelling: 17 ... 32	-	162702	0.06
	2.5 mm² with lock, 16-pole, screw connector, blue for connecting the field signals to I/O modules, for intrinsically safe field circuits Labelling: 17 ... 32	-	162718	0.06
	2.5 mm² with lock, 16-pole, spring clamp connection, blue, for connecting the field signals to I/O modules, for intrinsically safe field circuits, incl. test jacks Labelling: 1 ... 16 Attention: An additional terminal is necessary for I/O module Series 9470 and 9482. Labelling: 17 ... 32	-	162695 ▲	0.06
	2.5 mm² with lock, 16-pole, spring clamp connection, blue for connecting the field signals to I/O modules, for intrinsically safe field circuits, incl. test jacks Labelling: 17 ... 32	-	162716 ▲	0.06
Labelling strips				
	"FB Addr ... Mod No ..." for pluggable terminal, 26 pieces on the sheet	-	162788	-
DIN A4 sheet				
	For the label plate on I/O modules, 6 labels per sheet Print IS Wizard, packaging unit = 20 sheets	-	162832	-

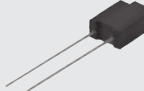
Accessories				
Figure	Description	Product Type	Art. No.	Weight lb
Partition				
	For mounting between intrinsically safe and non-intrinsically safe connections of the I/O modules, in order to adhere to the required 50 mm distance	-	220101 ▲	0.02
Warning sign				
	"Clean modules only with a damp cloth."	-	162796	-
Resistor error message suppression				
	The resistors are used to suppress error messages for unused I/O channels Resistance value: 62R / 0.5 W Suitable for: AOM 9468; TIM 9482	-	244912	-

06 b

Dimensional Drawings (All Dimensions in mm [inches]) – Subject to Alterations

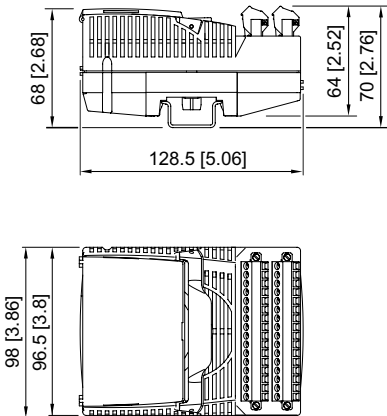

Ex i Inputs

Connectable resistance temperature detectors / resistance transmitters	Type	Reference	Measuring range (ITS-90)	Medium resolution	
	Pt100	IEC 60751	200 ... +850 °C	0.1 K	
	Pt500	IEC 60751	-200 ... +850 °C	0.1 K	
	Pt1000	IEC 60751	-200 ... +850 °C	0.1 K	
	Ni100	DIN 43760	-60 ... +180 °C	0.1 K	
	Ni500	DIN 43760	-60 ... +180 °C	0.1 K	
	Ni1000	DIN 43760	-60 ... +180 °C	0.1 K	
	Pt46	GOST 6651-94	-200 ... +1100 °C	0.15 K	
	Pt50	GOST 6651-94	-200 ... +1100 °C	0.15 K	
	Pt100	GOST 6651-94	-200 ... +1100 °C	0.1 K	
	Cu53	GOST 6651-94	-50 ... +180 °C	0.1 K	
	M50	GOST 6651-94	-200 ... +200 °C	0.15 K	
	M100	GOST 6651-94	-200 ... +200 °C	0.1 K	
	Resistance transmitter (3-wire)	--	0 ... 500 Ω	0.02 Ω	
	Resistance transmitter (3-wire)	--	0 ... 2.5 kΩ	0.10 Ω	
	Resistance transmitter (3-wire)	--	0 ... 5 kΩ	0.20 Ω	
	Resistance transmitter (3-wire)	--	0 ... 10 kΩ	0.4 Ω	
	Resistance transmitter (3-wire)	--	-200 ... +850 °C	0.1 K	
	Joystick (4-wire)	--	500 ... 10 kΩ		
Connectable thermocouples / mV sensors	Type	Reference	Measuring range (ITS-90)	Medium resolution	Medium error of measurement with regard to measuring range
	B	IEC 60584-1	-400 ... +1800 °C	0.25 K	0.1 %
	E	IEC 60584-1	-200 ... +1000 °C	0.1 K	0.013 %
	J	IEC 60584-1	-200 ... +1200 °C	0.1 K	0.014 %
	K	IEC 60584-1	-200 ... +1370 °C	0.1 K	0.02 %
	N	IEC 60584-1	-200 ... +1300 °C	0.1 K	0.02 %
	R	IEC 60584-1	-50 ... +1767 °C	0.2 K	0.05 %
	S	IEC 60584-1	-50 ... +1767 °C	0.2 K	0.053 %
	T	IEC 60584-1	-200 ... +400 °C	0.1 K	0.042 %
	L	DIN 43710	-200 ... +900 °C	0.1 K	0.027 %
	U	DIN 43710	-200 ... +600 °C	0.1 K	0.038 %
	XK	GOST 8.585	-50 ... +800 °C	0.1 K	0.02 %
	mV	--	0 ... +100 mV	3.6 μV	0.01 %

06 b



- For the internal electrical connection between CPU & power module and 8 I/O modules for Div. 1, Zone 1 and 16 I/O modules for Div. 2, Zone 2
- Redundant data bus, power bus with high availability
- Simple, protected installation in NS35/15 DIN rails
- Passive component with redundancy and high availability

WebCode **9494A**



06 b

The series 9494 bus rails are used as a backplane bus for the IS1+ remote I/O system. They include an Ex i power bus boasting high availability, a redundant Ex i data bus and address lines. The bus rails are available for 2 or 4 modules and can be combined for up to 18 slots. The BusRail extension cable can be used to place BusRail segments anywhere in the field enclosure.

	NEC® 500 CEC Appendix J					
	Class I		Class II		Class III	
Division	1	2	1	2	1	2
Ex interface						
Installation in	•	•				

	CEC Section 18					
	NEC® 505 Class I			NEC® 506		
Zone	0	1	2	20	21	22
Ex interface						
Installation in		•	•			

	IECEX / ATEX					
	Zone	0	1	2	20	21
Ex interface						
Installation in		•	•		•	•

Selection Table						
Product variant Remote I/O IS1+ BusRail						
Figure	Version	Max. BusRail length	Product Type	Art. No.	Weight lb	
	For 2 modules, beginning	118 in / 3 m, incl. connection cable	9494/S1-B2	261798	0.14	
	For 2 modules, end	118 in / 3 m, incl. connection cable	9494/S1-E2	261799	0.14	
	For 4 modules	118 in / 3 m, incl. connection cable	9494/S1-M4	261800 ▲	0.22	
Product variant Remote I/O IS1+ BusRail connecting line						
Figure	Version	Max. BusRail length	Product Type	Art. No.	Weight lb	
	27.56 in / 70 cm	118 in / 3 m, incl. connection cable	9494/L1-V7	261795	0.46	
	43.31 in / 110 cm	118 in / 3 m, incl. connection cable	9494/L1-V8	261796 ▲	0.57	
	Length in acc. with specific.	118 in / 3 m, incl. connection cable	9494/L1-V9	162867	0.15	
Product variant Remote I/O IS1+ BusRail end piece						
Figure	Version	Max. BusRail length	Product Type	Art. No.	Weight lb	
	Beginning	–	9494/A1-B0	261933 ▲	0.1	

Selection Table

Product variant		Remote I/O IS1+ BusRail			
Figure	Version	Max. BusRail length	Product Type	Art. No.	Weight lb
	End	-	9494/A1-E0	261934	0.1

Technical Data

Explosion Protection	
USA certificate FM	FM17US0332X
CAN certificate FM	FM16CA0134X
USA marking FM	IS; Class I,II,III, Div. 1, GP A,B,C,D; Class I, Zone 1, AEx ia IIC; T4 at Ta = 75°C; See Doc. 9494 6 031 001 1
CAN marking FM	IS; Class I,II,III, Div. 1, GP A,B,C,D; Class I, Zone 1, Ex ia IIC; T4 at Ta = 75°C; See Doc. 9494 6 031 001 1
IECEx gas explosion protection	Ex ia IIC T4 Gb
Certificates	ATEX (PTB), Canada (FM), EAC (Sertium), IECEx (PTB), Korea (KTL), USA (FM)
Electrical Data	
Engineering note	The BusRail is available in lengths for 2 or 4 modules. One end piece each is necessary at the beginning and the end. The end pieces are available as "BusRail beginning" and "BusRail end" as well as with an integrated connecting line. The connecting line allows for multiple BusRail segments to be set up in one enclosure.
Ambient Conditions	
Ambient temperature °F	-40°F ... +167°F
Ambient temperature °C	-40°C ... +75°C

Dimensional Drawings (All Dimensions in mm [inches]) – Subject to Alterations

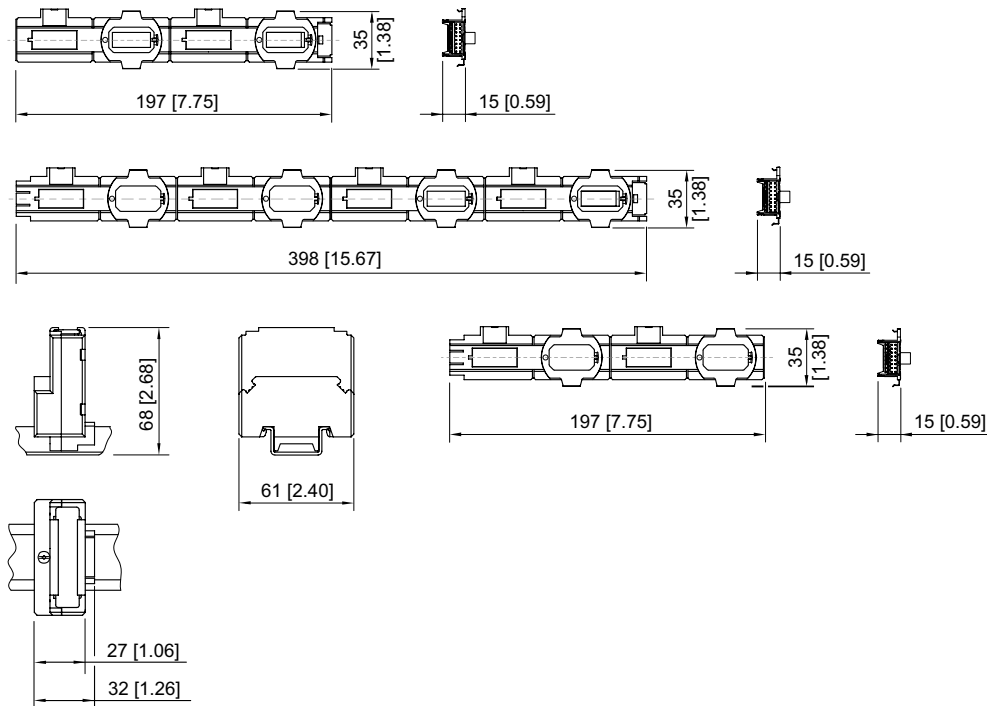

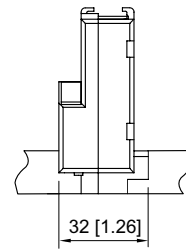
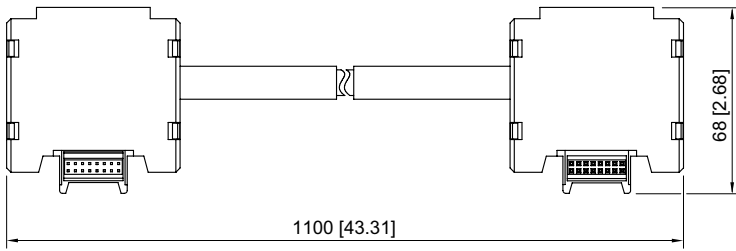
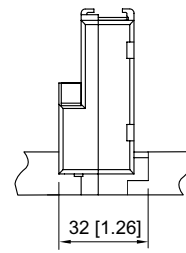
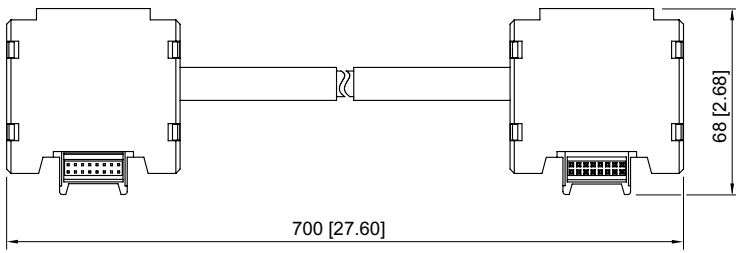

06 b

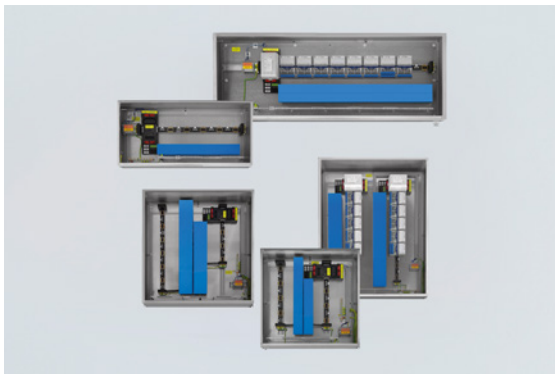

- Ready to install in NEC; CEC Class I, Div. 1
- 316SS NEMA 4X enclosures (based on 8150 series)
- I/O modules need to be purchased separately
- Ex interface depends on selected I/O modules

06 b

WebCode 81500



With the IS1+ standard enclosures for Cl. I, Div. 1, we offer you a variety of prefabricated field enclosures made from stainless steel 316SS. The communication module, power module, bus rails and sockets are included and already installed in the enclosure. Only need to add the I/O modules and entries to the system.

	NEC® 500 CEC Appendix J						CEC Section 18						IECEx / ATEX					
	Class I		Class II		Class III		NEC® 505 Class I			NEC® 506			0		20		22	
Division	1	2	1	2	1	2	0	1	2	20	21	22	0	1	2	20	21	22
Ex interface																		
Installation in	•	•			•			•	•						•			

Selection Table				
Dimensions (WxHxD)		23.6 in x 23.6 in x 9.1 in / 600 mm x 600 mm x 230 mm		
Product Description		IS1+ Remote I/O Standard enclosure NEC/CEC with shield bar, blue wire duct and communication Gateway		
Product variant	Built-in unit 1	Built-in unit 2	Product Type	Art. No.
Ethernet IP for up to 4 I/O Modules	1 x BusRail for 4 slots (1 x CPM, 4 x I/O - modules)	1 x Socket simple Ethernet IP 9492/13-13-41	S-EIP-C1D1-04	276992
Modbus TCP for up to 4 I/O Modules	1 x BusRail for 4 slots (1 x CPM, 4 x I/O - modules)	1 x Socket simple Modbus TCP 9492/13-13-11	S-TCP-C1D1-04	276994
ProfiNET for up to 4 I/O Modules	1 x BusRail for 4 slots (1 x CPM, 4 x I/O - modules)	1 x Socket simple ProfiNET 9492/13-13-31	S-PN-C1D1-04	276993
Dimensions (WxHxD)		29.9 in x 29.9 in x 11.8 in / 760 mm x 760 mm x 300 mm		
Product Description		IS1+ Remote I/O Standard enclosure NEC/CEC with shield bar, blue wire duct and Gateway		
Product variant	Built-in unit 1	Built-in unit 2	Product Type	Art. No.
Ethernet IP for up to 8 I/O Modules	1 x BusRail for 8 slots (1 x CPM, 8 x I/O - modules)	1 x Socket simple Ethernet IP 9492/13-13-41	S-EIP-C1D1-08	276995
Modbus TCP for up to 8 I/O Modules	1 x BusRail for 8 slots (1 x CPM, 8 x I/O - modules)	1 x Socket simple Modbus TCP 9492/13-13-11	S-TCP-C1D1-08	276997
ProfiNET for up to 8 I/O Modules	1 x BusRail for 8 slots (1 x CPM, 8 x I/O - modules)	1 x Socket simple ProfiNET 9492/13-13-31	S-PN-C1D1-08	276996
Dimensions (WxHxD)		39.4 in x 47.2 in x 11.8 in / 1000 mm x 1200 mm x 300 mm		
Product Description		IS1+ Remote I/O Standard enclosure NEC/CEC with shield bar, blue wire duct and Gateway		
Product variant	Built-in unit 1	Built-in unit 2	Product Type	Art. No.
Ethernet IP for up to 16 I/O Modules	1 x BusRail for 16 slots (2 x CPM, 16 x I/O - modules)	2 x Socket simple Ethernet IP 9492/13-13-41	S-EIP-C1D1-16	276998
Modbus TCP for up to 16 I/O Modules	1 x BusRail for 16 slots (2 x CPM, 16 x I/O - modules)	2 x Socket simple Modbus TCP 9492/13-13-11	S-TCP-C1D1-16	277000
ProfiNET for up to 16 I/O Modules	1 x BusRail for 16 slots (2 x CPM, 16 x I/O - modules)	2 x Socket simple ProfiNET 9492/13-13-31	S-PN-C1D1-16	276999

Once the IS1+ components (available separately) have been installed, the enclosures can be used in Cl. I, Div. 1.

Standard Solution: Drawings are provided upon request.

Technical Data			
Variant	S...-C1D1-04	S...-C1D1-08	S...-C1D1-16
Explosion Protection			
USA certificate FM	FM17US0332X	FM17US0332X	FM17US0332X
CAN certificate FM	FM16CA0134X	FM16CA0134X	FM16CA0134X
IECEX certificate Gas	yes	yes	yes
USA marking FM	Class I, Div. 1 & 2, Groups A, B, C, D	Class I, Div. 1 & 2, Groups A, B, C, D	Class I, Div. 1 & 2, Groups A, B, C, D
CAN marking FM	Class I, Div. 1 & 2, Groups A, B, C, D	Class I, Div. 1 & 2, Groups A, B, C, D	Class I, Div. 1 & 2, Groups A, B, C, D
Notes	Explosion protection is based on the I/O modules installed		
Electrical Data			
Grounding connection version	External M8 grounding connection	External M8 grounding connection	External M8 grounding connection
Applicable IS1+ modules note	I/O modules need to be ordered and installed separately. I/O modules require terminal blocks for field wire connection.	I/O modules need to be ordered and installed separately. I/O modules require terminal blocks for field wire connection.	I/O modules need to be ordered and installed separately. I/O modules require terminal blocks for field wire connection.
Auxiliary Power			
Auxiliary power rated operating voltage	24 V DC (20 ... 35 V DC)	24 V DC (20 ... 35 V DC)	24 V DC (20 ... 35 V DC)
Device Specific Data			
Cable duct	1 x (3"x4"x21")	1 x (3"x4"x21")	1 x (3"x4"x21")
Shield bus	yes	yes	yes
Front door	1 x opening upwards 3 x cam locks with cover support right	1 x opening upwards 3 x cam locks with cover support right	1 x opening upwards 3 x cam locks with cover support right
Ambient Conditions			
Ambient temperature °F	-4 °F ... +149 °F	-4 °F ... +149 °F	-4 °F ... +149 °F
Ambient temperature °C	-20 °C ... +65 °C	-20 °C ... +65 °C	-20 °C ... +65 °C
Mechanical Data			
Degree of protection (NEC UL 50)	NEMA 4X	NEMA 4X	NEMA 4X
Degree of protection (IP)	IP65	IP65	IP65
Enclosure material	Stainless steel, (AISI 316L) brush finished	Stainless steel, (AISI 316L) brush finished	Stainless steel, (AISI 316L) brush finished
Sealing material	Silicon foam gasket	Silicon foam gasket	Silicon foam gasket
Silicone-free	no	no	no
Wall thickness inches	1.5"	1.5"	1.5"
Wall thickness	38 mm	38 mm	38 mm
Mounting / Installation			
Mounting position	horizontal	horizontal	horizontal
Connection type	screw connection	screw connection	screw connection
Components			
Built-in unit 3	1 x CPU 9441/12-00-00	1 x CPU 9441/12-00-00	2 x CPU 9441/12-00-00
Built-in unit 3 note	Communication is done via fiber optic [op is]. Media converter series 9721 needs to be purchased separately.	Communication is done via fiber optic [op is]. Media converter series 9721 needs to be purchased separately.	Communication is done via fiber optic [op is]. Media converter series 9721 needs to be purchased separately.
Built-in unit 4	1 x Power module (9444/12-11)	1 x Power module (9444/12-11)	2 x Power module (9444/12-11)
Built-in unit 5	1 x conduit hub 9491/00-13-70 included in the enclosure	1 x conduit hub 9491/00-13-70 included in the enclosure	1 x conduit hub 9491/00-13-70 included in the enclosure
Cable Glands	No cable glands included.	No cable glands included.	No cable glands included.
Entry 1	1/2" conduit entry provided	1/2" conduit entry provided	1/2" conduit entry provided
Cable entry note	The entries should be done so that the enclosure maintains NEMA 4X rating. Contact factory for additional details if necessary.	The entries should be done so that the enclosure maintains NEMA 4X rating. Contact factory for additional details if necessary.	The entries should be done so that the enclosure maintains NEMA 4X rating. Contact factory for additional details if necessary.

06 b

Dimensional Drawings (All Dimensions in mm [inches]) – Subject to Alterations

06 b

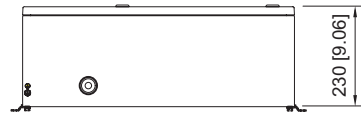
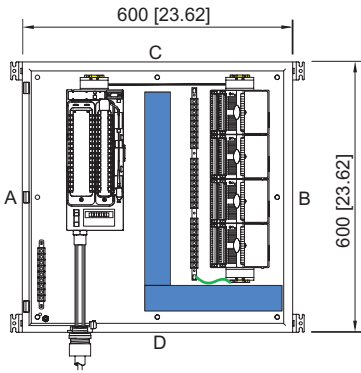

S...-C1D1-04

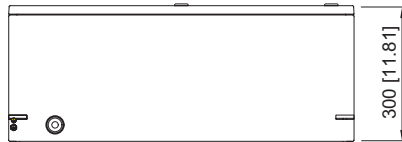
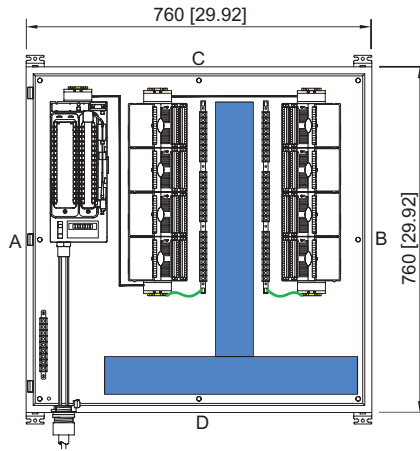

S...-C1D1-08

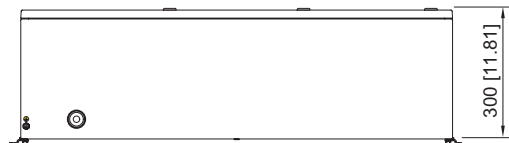
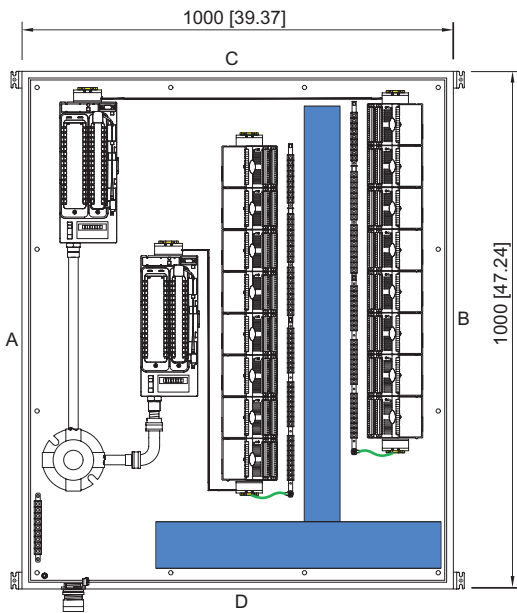

S...-C1D1-16



- Ready to install in NEC; CEC Class I, II, Div. 2 and Zone 2 areas
- 316SS NEMA 4X enclosures (based on 8150)
- I/O modules need to be purchase separately
- Ex interface depends on selected I/O modules

WebCode **8150N**



06 b

With the IS1+ standard enclosures for Cl. I, II, Div. 2 and Zone 2, we offer you a variety of prefabricated field enclosures made from stainless steel 316SS. The communication module, power module, bus rails and sockets are included and already installed in the enclosure. Only need to add the I/O modules and entries to the system.

	NEC® 500 CEC Appendix J					
	Class I		Class II		Class III	
Division	1	2	1	2	1	2
Ex interface						
Installation in		•		•		

	CEC Section 18					
	NEC® 505 Class I			NEC® 506		
Zone	0	1	2	20	21	22
Ex interface						
Installation in			•			

	IECEX / ATEX					
	Zone	0	1	2	20	21
Ex interface						
Installation in			•			

Selection Table				
Product Description	IS1+ Remote I/O Standard enclosure NEC/CEC with shield bar, wire duct and Gateway			
Dimensions (WxHxD)	Built-in unit 1	Built-in unit 2	Product Type	Art. No.
23.6 in x 23.6 in x 9.1 in 600 mm x 600 mm x 230 mm	1 x BusRail for 8 slots (1 x CPM, 7 x I/O - modules)	1 x Socket 9496/35-03-00	S-MP-C1D2-07	277002
30.9 in x 18.8 in x 9.1 in 787 mm x 480 mm x 230 mm	1 x BusRail for 6 slots (1 x CPM, 5 x I/O - modules)	1 x Socket 9496/35-03-00	S-MP-C1D2-05	277001
31.5 in x 39.7 in x 11.8 in 800 mm x 1000 mm x 300 mm	1 x BusRail for 12 slots (1 x CPM, 11 x I/O - modules)	1 x Socket 9496/35-03-00	S-MP-C1D2-11	277003
31.5 in x 39.7 in x 11.8 in 800 mm x 1000 mm x 300 mm	1 x BusRail for 16 slots (1 x CPM, 15 x I/O - modules)	1 x Socket 9496/35-03-00	S-MP-C1D2-15	277004

Once the IS1+ components (available separately) have been installed, the enclosures can be used in Cl. I, II, Div. 2 and Class I, Zone 2 as well as Zone 2.

Standard Solution: Drawings are provided upon request.

Technical Data	
Explosion Protection	
USA certificate FM	FM17US0332X
CAN certificate FM	FM16CA0134X
IECEX certificate Gas	yes
USA gas explosion protection FM	Class I, Div. 2, Groups A, B, C, D; Class I, Zone 2, AEx ... T4 Gc
USA marking FM	Class I, Div. 2, Groups A, B, C, D; Class I, Zone 2, AEx ... T4 Gc
CAN marking FM	Class I, Div. 2, Groups A, B, C, D; Class I, Zone 2, Ex ... T4 Gc
Notes	Explosion protection is based on the I/O modules installed

Technical Data

Electrical Data

Protocols	Profibus DP Ethernet IP Modbus TCP ProfiNet
Grounding connection version	External M8 grounding connection
Applicable IS1+ modules note	I/O modules need to be ordered and installed separately. I/O modules require terminal blocks for field wire connection.

Auxiliary Power

Auxiliary power rated operating voltage	24 V DC (20 ... 35 V DC)
---	--------------------------

Device Specific Data

Cable duct	1 x (3"X4"X21")
Shield bus	yes
Front door	1 x opening upwards 3 x cam locks with cover support right

Ambient Conditions

Ambient temperature °F	-40 °F ... +167 °F
Ambient temperature °C	-40 °C ... +75 °C

Mechanical Data

Degree of protection (NEC UL 50)	NEMA 4X
Degree of protection (IP)	IP65
Enclosure material	Stainless steel, (AISI 316L) brush finished
Sealing material	Silicon foam gasket
Silicone-free	no
Wall thickness inches	1.5"
Wall thickness	38 mm

Mounting / Installation

Mounting position	horizontal / vertical
Connection type	screw connection

Components

Built-in unit 3	1 x CPU 9442/35-10-00
Built-in unit 4	1 x Power module 9445/35-12 and connector Art. No. 261232
Cable Glands	No cable glands included.
Entry 1	No entries provided
Cable entry note	The entries should be done so that the enclosure maintains NEMA 4X rating. Contact factory for additional details if necessary.
Type of terminals 1	2 x UT2.5
Type of grounding terminal 1	1 x UT2.5-PE

06 b

IS1+ Remote I/O Standard Enclosure NEC/CEC

for Cl. I, II, Div. 2 and Zone 2



Dimensional Drawings (All Dimensions in mm [inches]) – Subject to Alterations

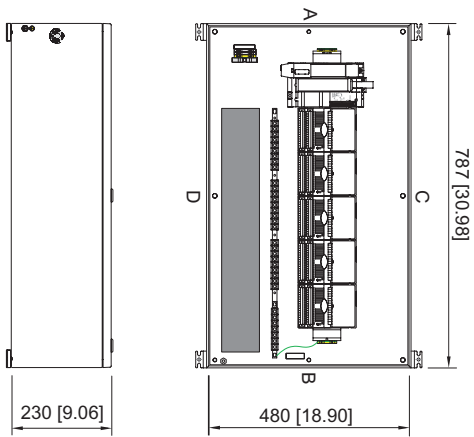

S-MP-C1D2-05

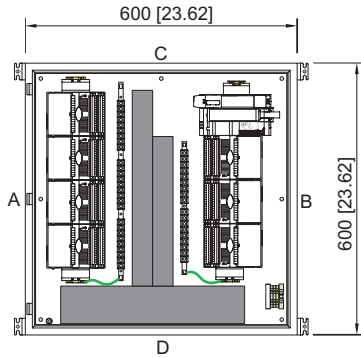

S-MP-C1D2-07

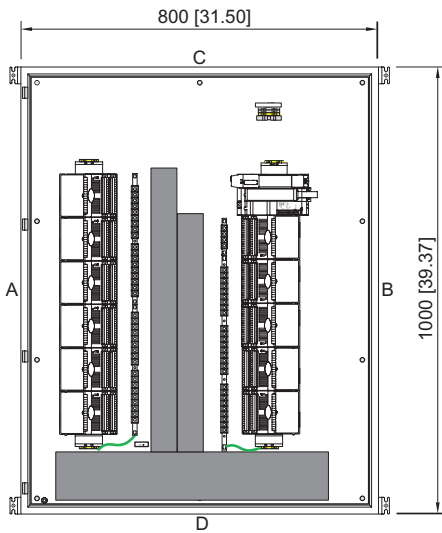

S-MP-C1D2-11

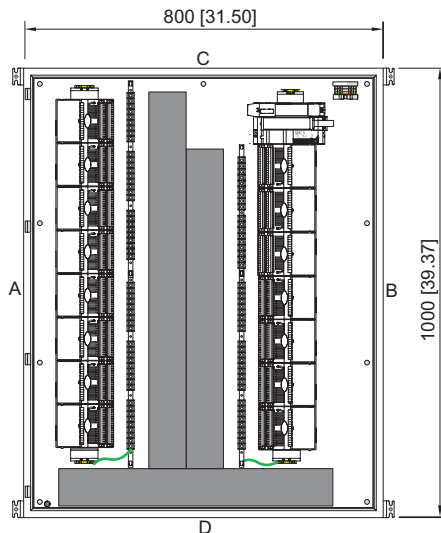

S-MP-C1D2-15

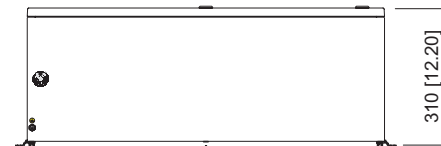
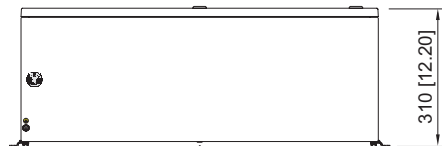

06 b

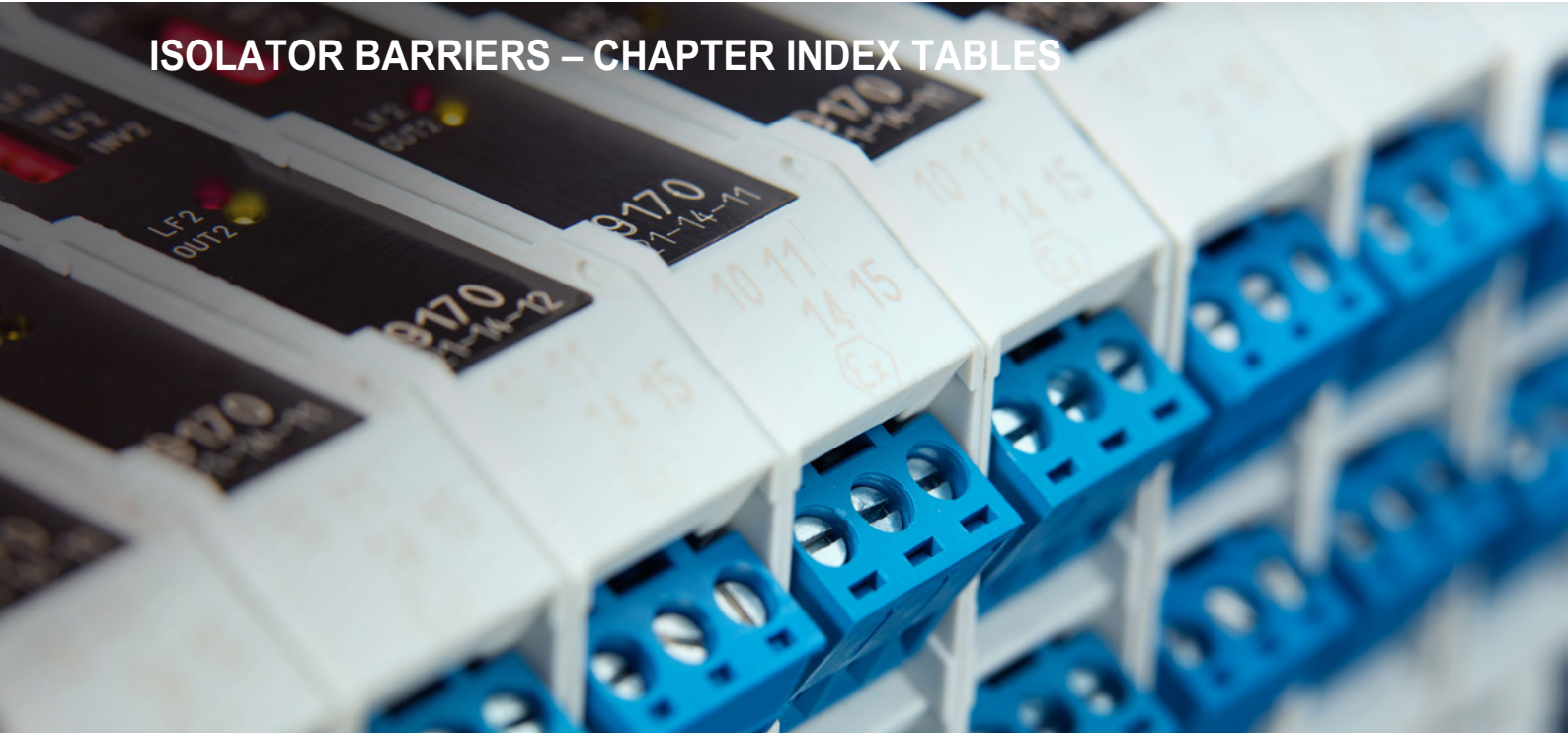

ISOLATOR BARRIERS – CHAPTER INDEX TABLES

Product	Series	Page	WebCode
Isolator Barriers – Chapter Index Tables			
Binary Output (Discrete Output)		144	
Fieldbus Isolating Repeater		147	
Frequency Transmitter		139	
Isolating Repeater (Analog Output)		142	
Isolating Switching Repeater (Discrete Input)		143	
Relay Module		145	
Resistance Isolators and Temperature Transmitter		146	
Transmitter Supply (Analog Input)		141	
Vibration Transducer Supply		140	

For additional products and information please refer to r-stahl.com

Frequency Transmitter



ISpac series 9146
(can be found on page 152)

	9146/10-11-12	9146/20-11-11
Product type		
Function		
Monitoring the speed of rotating devices like fans, centrifuges, tube extruders, ...	X	X
Number of channels		
Number of channels	1	2
Footprint		
17.6 mm / 0.69 inches	X	X
Explosion protection		
Installation in Zone 2; Class I, Div. 2	X	X
I.S. interface [Zone 0 and 20]; Class I, II, III, Div. 1	X	X
I.S. input signal		
acc. to IEC/EN 60947-5-6 (NAMUR)	X	X
Input frequency 0.001 Hz ... 20 kHz	X	X
Output signal		
0/4 ... 20 mA	X	X
Trip amplifier		
2 x NO/NC	X	
Pulse output		
one NO selectable	X	
Power supply		
24 V DC	X	X
Line fault signalization		
via output signal (0/4 ... 20 mA)	X	X
via LED	X	X
via contact (terminal)	X	X
via contact (pac-Bus)	X	X
Ambient temperature (operation)		
-4 ... +140 °F (+158 °F single device installation)	X	X

07 a

Vibration Transducer Supply

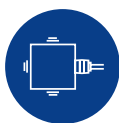

ISpac series 9147
(can be found on page 154)

07 a

	9147/10-99-10	9147/20-99-10
Product type		
Function		
for intrinsically safe operation of vibration transducer supply, speed and acceleration sensors	X	X
Number of channels		
Number of channels	1	2
Footprint		
17.6 mm / 0.69 inches	X	X
Explosion protection		
Installation in Zone 2; Class I, Div. 2	X	X
I.S. interface [Zone 0 and 20]; Class I, II, III, Div. 1	X	X
SIL		
SIL (IEC 61508)	2	2
I.S. input signal		
Input signal -0.5 ... -20 V	X	X
Functional range 0 ... -24 V	X	X
Output signal		
-0.5 ... -20 V	X	X
Power supply		
24 V DC	X	X
Ambient temperature (operation)		
-4 ... +140 °F (+158 °F single device installation)	X	X

Transmitter Supply (Analog Input)



ISpac series 9260
(can be found on page 160)



ISpac series 9160
(can be found on page 156)



ISpac series 9162
(can be found on page 163)



ISpac series 9164
(can be found on page 165)

	9260/13-11-10	9160/13-11-11	9160/13-11-13	9260/19-11-10	9160/19-11-11	9260/23-11-10	9160/23-11-11	9160/23-10-10	9162/13-11-14	9164/13-20-08
Product type										
Function										
Transmitter supply with HART	X	X	X	X	X	X	X	X	X	
Isolating repeater for 4-wire	X	X	X	X	X	X	X	X	X	X
Isolating repeater for 4-wire HART	X			X						X
Trip amplifier									X	
Number of channels										
Number of channels	1	1	1	1	1	2	2	2	1	1
Signal duplication										
Signal duplication				X	X					
Footprint										
12.5 mm / 0.49 inches	X			X		X				X
17.6 mm / 0.69 inches		X	X		X		X	X	X	
Explosion protection										
Installation in Zone 2; Class I, Div. 2	X	X	X	X	X	X	X	X	X	
Installation in Zone 1; Class I, Div. 1										X
I.S. interface [Zone 0 and 20]; Class I, II, III, Div. 1	X	X	X	X	X	X	X	X	X	X
SIL										
SIL (IEC 61508)	2	2	3	2	2	2	2	2	2	2
I.S. output signal										
0/4 ... 20 mA with HART	X	X	X	X	X	X	X	X	X	X
Output signal A										
0/4 ... 20 mA Source/Active with HART	X	X	X	X	X	X	X		X	
0/4 ... 20 mA Sink/Passive with HART	X							X		
0/4 ... 20 mA Sink/Passive with HART (I.S.)										X
Output signal B										
0/4 ... 20 mA Source/Active without HART				X	X					
0/4 ... 20 mA Source/Active with HART						X	X			
0/4 ... 20 mA Sink/Passive with HART								X		
Trip amplifier contact										
2 x NO/NC									X	
Power supply										
24 V DC	X	X	X	X	X	X	X	X	X	
Line fault signalization										
via output signal	X	X	X	X	X	X	X	X	X	
via LED		X	X		X		X		X	
via contact (terminal)		X	X		X		X		X	
via contact (pac-Bus)		X	X		X		X		X	
Ambient temperature (operation)										
-4 ... +140 °F (+158 °F single device installation)		X	X		X		X	X		
-4 ... +140 °F	X			X		X				
-40 ... +158 °F									X	X

07 a

Isolating Repeater (Analog Output)



ISpac series 9265
(can be found on page 169)



ISpac series 9165
(can be found on page 167)



ISpac series 9167
(can be found on page 171)

07 a

	9265/16-11-10	9165/16-11-11	9265/26-11-10	9165/26-11-11	9167/11-11-00	9167/13-11-00	9167/23-11-00
Product type							
Function							
intrinsically safe operation of control valves, i/p-converters or indicators, ...	X	X	X	X	X	X	X
Number of channels							
Number of channels	1	1	2	2	1	1	2
Footprint							
12.5 mm / 0.49 inches	X		X				
17.6 mm / 0.69 inches		X		X	X	X	X
Explosion protection							
Installation in Zone 2; Class I, Div. 2	X	X	X	X	X	X	X
I.S. interface [Zone 0 and 20]; Class I, II, III, Div. 1	X	X	X	X	X	X	X
SIL							
SIL (IEC 61508)	2	2	2	2	3	3	3
Input signal							
0/4 ... 20 mA with HART	X	X	X	X	X	X	X
I.S. output signal							
0/4 ... 20 mA with HART	X	X	X	X	X	X	X
max. load resistance R_L							
360 Ω					X		
700 Ω	X		X				
800 Ω		X		X		X	X
Power supply							
24 V DC	X	X	X	X			
Loop powered					X	X	X
Line fault signalization							
via output signal	X	X	X	X			
via LED		X		X			
via contact (terminal)		X		X			
via contact (pac-Bus)		X		X			
Ambient temperature (operation)							
-4 ... +140 °F (+158 °F single device installation)		X		X	X	X	X
-40 ... +158 °F	X		X				

Isolating Switching Repeater (Discrete Input)



ISpac series 9170
(can be found on page 174)



ISpac series 9270
(can be found on page 178)

	9270/11-16-14	9270/11-17-15	9270/11-19-15	9170/11-11-11	9170/11-12-11	9170/11-13-21	9270/21-17-14	9270/21-14-14	9170/21-10-11	9170/21-11-11	9170/21-12-11	9170/21-12-21	9170/21-14-11	9170/21-14-12
Product type														
Function	for intrinsically safe operation of contacts, proximity sensors, etc.													
Number of channels	Number of channels													
	1	1	1	1	1	1	1	2	2	2	2	2	2	2
Footprint	Footprint													
	12.5 mm / 0.49 inches													
	X	X	X				X	X						
	17.6 mm / 0.69 inches													
				X	X	X			X	X	X	X	X	X
Explosion protection	Explosion protection													
	Installation in Zone 2; Class I, Div. 2													
	X	X	X	X			X	X	X	X			X	X
	I.S. interface [Zone 0 and 20]; Class I, II, III, Div. 1													
	X	X	X	X	X	X	X	X	X	X	X	X	X	X
SIL	SIL (IEC 61508)													
	2	2	2	2	2	2	2	2	2	2	2	2	2	2
I.S. input signal	I.S. input signal													
	acc. to IEC/EN 60947-5-6 (Namur)													
	X	X	X	X	X	X	X	X	X	X	X	X	X	X
Output signal per channel	Output signal per channel													
	Changeover contact (125 V / 1 A)													
				2					1					
	Changeover contact (250 V / 2 A)													
	1													
	Changeover contact (250 V / 4 A)													
				1	2						1	2		
	NO (125 V / 1 A)													
										2				
	NO (250 V / 2 A)													
		2					1							
	Electronic (35 V / 50 mA)													
													1	
	Electronic (35 V / 50 mA) LFT													
														1
	Electronic (30 V / 50 mA)													
			2					1						
Switching frequencies	Switching frequencies													
	≤ 6 Hz													
					X	X					X	X		
	≤ 15 Hz													
	X	X		X			X		X	X				
	≤ 5 kHz													
			X					X						
	≤ 10 kHz													
													X	X
Power supply	Power supply													
	24 V DC													
	X	X	X	X	X		X	X	X	X	X		X	X
	110 ... 230 V													
						X						X		
Line fault signalization	Line fault signalization													
	via input signal (LFT)													
														X
	via LED													
	X	X	X	X	X	X	X	X	X	X	X	X	X	X
	via contact (terminal)													
		X ¹⁾	X ¹⁾	X	X				X	X	X		X	X
	via contact (pac-Bus)													
	X ²⁾	X ²⁾	X ²⁾	X	X		X ²⁾	X ²⁾	X	X	X		X	X
Ambient temperature (operation)	Ambient temperature (operation)													
	-4 ... +140 °F (+158 °F single device installation)													
				X	X	X			X	X	X	X	X	X
	-4 ... +140 °F													
	X	X	X				X	X						

¹⁾ One output of the device can be selected to signalize line faults.

²⁾ Requires supply module 9193/21-11-11 for displaying the pac-Bus fault signalization.

07 a

Binary Output (Discrete Output)



ISpac series 9275
(can be found on page 187)



ISpac series 9175
(can be found on page 184)



ISpac series 9276
(can be found on page 192)



ISpac series 9176
(can be found on page 189)

07 a

	9275/10-21-25-11	9275/10-24-48-11	9175/10-16-11	9175/20-12-11	9175/20-14-11	9175/20-16-11	9276/10-21-25-00	9276/10-21-40-00	9276/10-21-60-00	9276/10-24-48-00	9176/10-16-00	9176/20-15-00	9176/20-16-00	9176/20-17-00
Product type														
Function														
for the intrinsically safe operation of Ex i solenoid valves or indicators	X	X	X	X	X	X	X	X	X	X	X	X	X	X
Number of channels														
Number of channels	1	1	1	2	2	2	1	1	1	1	1	2	2	2
Footprint														
12.5 mm / 0.49 inches	X	X					X	X	X	X				
17.6 mm / 0.69 inches			X	X	X	X					X	X	X	X
Explosion of protection														
Installation in Zone 2; Class I, Div. 2	X	X	X	X	X	X	X	X	X	X	X	X	X	X
I.S. interface [Zone 0 and 20]; Class I, II, III, Div. 1	X	X	X	X	X	X	X	X	X	X	X	X	X	X
SIL														
SIL (IEC 61508)	3	3	3	3	3	3	3	3	3	3	3	3	3	3
I.S. output signal														
[Ex ia] Groups A, B / IIC	X	X	X	X	X	X	X	X		X	X	X	X	X
[Ex ia] Group C / IIB									X					
Max. output current (I_{o,max})														
25 mA	X						X							
29 mA												X		
35 mA			X			X					X		X	
40 mA								X						X
45 mA					X									
48 mA		X								X				
58 mA									X					
60 mA				X										
Open-circuit voltage (U_o)														
10 V				X										
17.5 V					X									
21.5 V	X													
21.9 V							X	X	X					
24 V		X								X				
25 V			X			X					X	X	X	X
Power supply														
24 V DC	X	X	X	X	X	X								
Loop powered							X	X	X	X	X	X	X	X
Line fault signalization														
via LED	X	X	X	X	X	X								
via contact (terminal)	X	X	X	X	X	X								
via contact (pac-Bus)	X ¹⁾	X ¹⁾	X	X	X	X								
Ambient temperature (operation)														
-4 ... +140 °F (+158 °F single device installation)			X	X	X	X					X	X	X	X
-4 ... +140 °F	X	X												
-40 ... +140 °F							X	X	X	X				

¹⁾ Requires supply module 9193/21-11-11 for displaying the pac-Bus fault signalization.

Relay Module



ISpac series 9172
(can be found on page 181)

	9172/20-11-00	9172/21-11-00	9172/22-11-00
Product type			
Number of channels			
Number of channels	2	2	2
Footprint			
17.6 mm / 0.69 inches	X	X	X
Explosion protection			
Installation in Zone 2; Class I, Div. 2	X	X	X
I.S. interface [Zone 0 and 20]; Class I, II, III, Div. 1	X	X	X
SIL			
SIL (IEC 61508)	2	2	2
Input /control			
I.S.	X		X
Non I.S.		X	
Output per channel			
Changeover (250 V / 4 A)	1		
I.S., changeover (125 V / 4 A, 30 V / 4 A)		1	1
Switching frequency			
≤ 15 Hz	X	X	X
Ambient temperature (operation)			
-4 ... +140 °F (+158 °F single device installation)	X	X	X

07 a

Resistance Isolators and Temperature Transmitter (Temperature Input)



ISpac series 9180
(can be found on page 194)



ISpac series 9182
(can be found on page 197)



ISpac series 9282
(can be found on page 200)

07 a

	9180/10-77-11	9180/20-77-11	9180/11-77-11	9180/21-77-11	9282/11+51-16	9282/12-51-16	9182/10-51-11	9182/10-51-13	9182/10-51-14	9182/20-51-11	9182/20-50-12	
Product type												
Function												
Resistance isolators Pt100	X	X										
Resistance isolators Pt1000			X	X								
Temperature transmitter for RTD (e. g. Pt100)					X		X	X	X	X	X	
Temperature transmitter for thermocouples						X	X	X	X	X	X	
Number of channels												
Number of channels	1	2	1	2	1	1	1	1	1	2	2	
Footprint												
12.5 mm / 0.49 inches					X	X						
17.6 mm / 0.69 inches	X	X	X	X			X	X	X	X	X	
Explosion protection												
Installation in Zone 2, 22; Class I, II, III, Div. 2	X	X	X	X	X	X	X	X	X	X	X	
I.S. interface [Zone 0 and 20]; Class I, II, III, Div. 2	X	X	X	X	X	X	X	X	X	X	X	
SIL												
SIL (IEC 61508)					2	2		2	2			
Output signal												
0/4 mA ... 20 mA Source / Active					X	X	X	X	X	X		
Resistance	X	X	X	X								
Trip amplifier contact 2 x NO									X			
Configuration												
via Software					X	X	X	X	X	X	X	
via DIP-switch							X			X		
Auxiliary power												
24 V DC	X	X	X	X	X	X	X	X	X	X	X	
Line fault signalization												
via output signal	X	X	X	X	X	X	X	X	X	X	X	
via LED	X	X	X	X	X	X	X	X	X	X	X	
via contact (terminal)	X	X	X	X			X	X	X	X	X	
via contact (pac-Bus)	X	X	X	X			X	X	X	X	X	
Ambient temperature (operation)												
-4 ... +140 °F (+158 °F single device installation)	X	X	X	X			X	X	X	X	X	
-40 ... +158 °F					X	X						

Fieldbus Isolating Repeater



ISpac series 9185/11
(can be found on page 336)



ISpac series 9186/.5
(can be found on page 340)



ISpac series 9185/12
(can be found on page 338)

	9185/11-35-10	9185/11-45-10	9186/15-12-11	9186/25-12-11	9185/12-45-10
Product type					
Function					
Fieldbus isolating repeater	X	X			X
FO fieldbus isolating repeater			X	X	
Number of channels					
Number of channels	1	1	2	1	1
Interfaces					
Profibus DP / Modbus RTU		X	X	X	X
Ex i Profibus DP / Modbus RTU	X				
Explosion protection					
Installation in Zone 2, 22; Class I, II, III, Div. 2	X	X	X	X	X
I.S. interface [Zone 1 and 21]; Class I, II, III, Div. 1	X	X			
FO interface [Zone 0 and 20]; [Ex op is]			X	X	
Data rate					
1.2 kbit/s ... 1.5 Mbit/s	X	X			X
9.6 kbit/s ... 1.5 Mbit/s			X	X	
Fieldside interface					
RS 485 IS	X	X			
Ex op is			X	X	
RS 485					X
RS 422					X
RS 422 I.S.		X			
Safe area interface					
RS 485	X	X	X	X	X
RS 422	X	X			X
RS 232	X	X			X
Auxiliary power					
24 V AC / DC	X	X			X
24 V DC			X	X	

07 a

ISOLATOR BARRIERS



Product	Series	Page	WebCode
Ex i-Isolators – Analog Input			
mA-Isolating Repeater	9164	165	9164A
Transmitter Supply Unit	9160	156	9160A
Transmitter Supply Unit Slim Design 12.5 mm Wide	9260	160	9260A
Transmitter Supply Unit with Limit Value	9162	163	9162A
Vibration Transducer Supply Unit	9147	154	9147A
Ex i-Isolators – Analog Output			
Isolating Repeater	9165	167	9165A
Isolating Repeater Loop Powered	9167	171	9167A
Isolating Repeater Slim Design 12.5 mm Wide	9265	169	9265A
Ex i-Isolators – Digital Input			
Frequency Transmitter	9146	152	9146A
Switching Repeater	9170	174	9170A
Switching Repeater Slim Design 12.5 mm Wide	9270	178	9270A
Ex i-Isolators – Digital Output			
Binary Output	9175	184	9175A
Binary Output Slim Design 12.5 mm Wide	9275	187	9275A
Digital Output Loop Powered	9176	189	9176A
Digital Output Loop Powered Slim Design 12.5 mm Wide	9276	192	9276A
I.S. Relay Module	9172	181	9172A
Ex i-Isolators – Temperature Input			
Resistance Isolator	9180	194	9180A
Temperature Transmitter	9182	197	9182A
Temperature Transmitter Slim Design 12.5 mm Wide	9282	200	9282A
General			
General		151	ISpacA
Overview Network Structure with Isolators		150	

Product	Series	Page	WebCode
System Components			
HART Multiplexer	9192	202	9192A
HART Termination Board	9196	214	9196A
pac-Bus	9194	207	9194A
pac-Bus Slim Design 12.5 mm Wide	9294	209	9294A
pac-Carrier	9195	211	9195A
Supply Module	9193	205	9193A
Accessories and Spare Parts			
Accessories and Spare Parts ISpac		216	
Dimensional Drawings			
Dimensional Drawings ISpac		217	

For additional products and information please refer to r-stahl.com

07 b

07 b

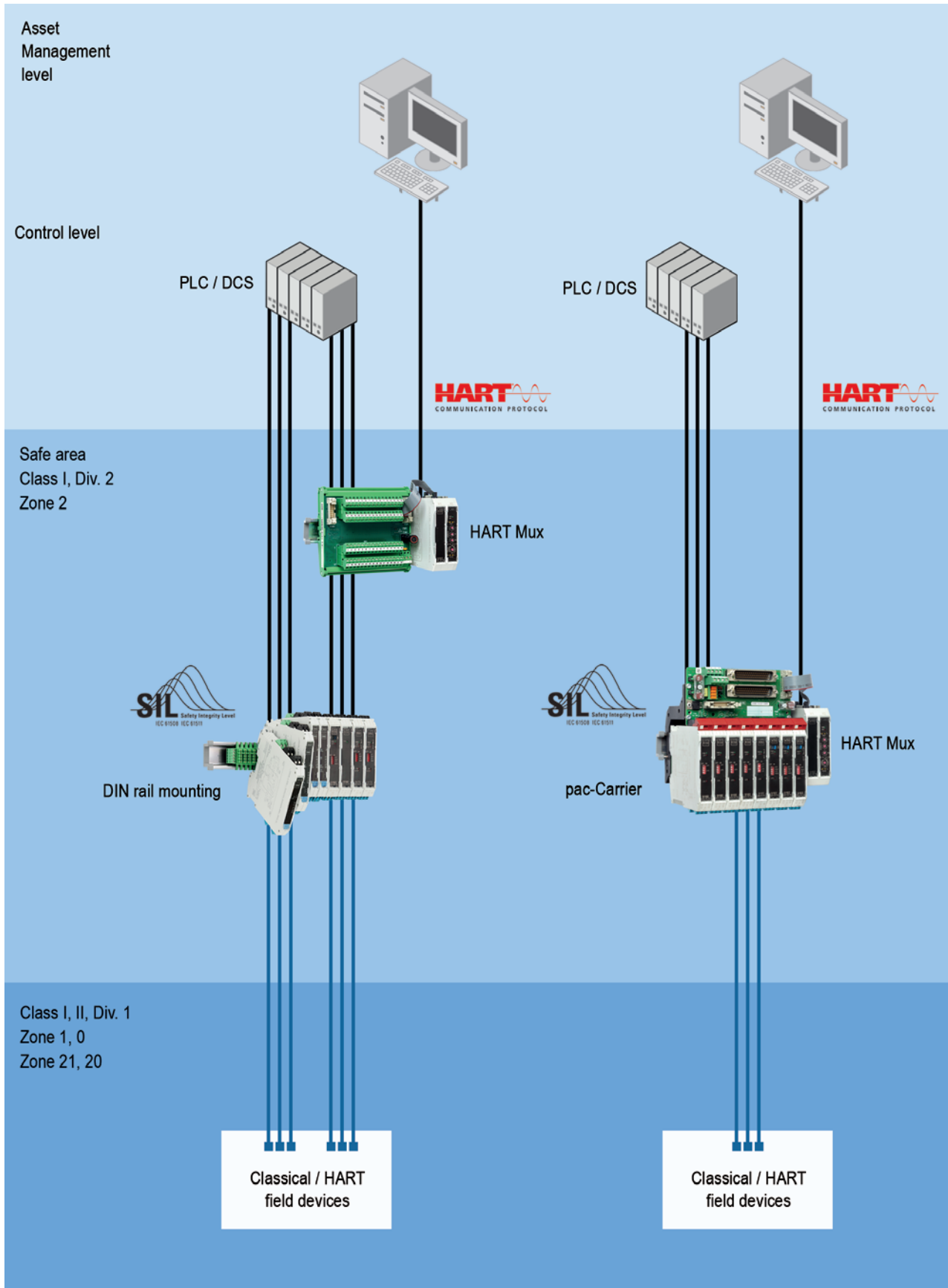

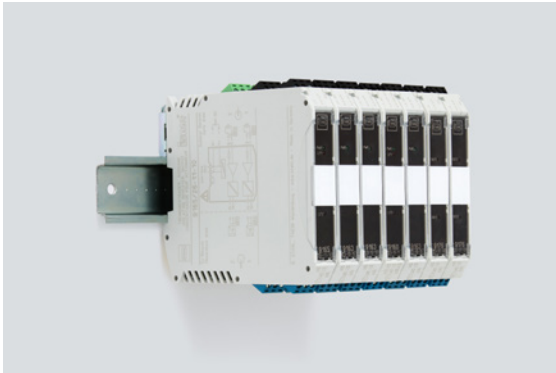

- New: modules with a width of just 12 mm
- Time-saving system for wiring: pac-Bus or pac-Carrier
- Wide array of applications: can be used for SIL applications up to SIL 3
- HART-capable

WebCode ISpacA



The combination of pac-Bus and ISpac isolators makes it incredibly easy to connect the auxiliary power supply and read error messages: All you need to do is snap the pac-Bus and the device onto the DIN rail and the wiring is complete; power is supplied via the DIN rail. This is the only such module on the market for which all devices can be mounted on a DIN rail or in the pac-Carrier.

All ISpac isolators for analogue signals can transmit HART signals. This combination of isolators, HART multiplexers and transmission boards enables efficient transmission of these signals to asset management systems.

Consequently, ISpac isolators were designed for functional safety and are rated at SIL 2 or SIL 3, including devices with a trip-amplifier function.

07 b



- Compact Ex i frequency transmitter for monitoring rotational speed in hazardous areas
- Limit value analysis + frequency-current conversion + pulse divider function over a width of just 17.6 mm
- Parameterization made easy by "ISpac Wizard" software

WebCode **9146A**



07 b

9146 series Ex i- frequency transmitters monitor the speed of rotating parts on one or two channels, e.g. the speed of fans or centrifuges. The frequency measured at the intrinsically safe input (between 0.001 Hz and 20 kHz) is issued as a unit signal (0/4 mA to 20 mA) or processed by a frequency divider. In single-channel devices, these frequency transmitters check whether speeds have exceeded or fallen below the limit values.

	NEC® 500 CEC Appendix J						CEC Section 18 NEC® 505 NEC® 506						IECEX / ATEX					
	Class I		Class II		Class III		Class I			Class I			Zone 0		Zone 1		Zone 2	
Division	1	2	1	2	1	2	0	1	2	20	21	22	0	1	2	20	21	22
Ex interface	•	•	•	•	•	•	•						•	•	•	•	•	•
Installation in		•							•						•			

Selection Table						
Number of channels	1					
Output signal	Limit contact (per channel)	Pulse output	Product Type	Art. No.	Weight lb	
0/4 – 20 mA	2 NO / NC	One configurable NO	9146/10-11-12s	159883 ▲	0.28	
Number of channels	2					
Output signal	Limit contact (per channel)	Pulse output	Product Type	Art. No.	Weight lb	
0/4 – 20 mA	Without	Without	9146/20-11-11s	159886	0.3	

The order numbers listed in the table are for devices equipped with screw terminals.
Further versions available at r-stahl.com

Technical Data		
Variant	Number of channels 1	Number of channels 2
Explosion Protection		
USA certificate FM	FM16US0122X	FM16US0122X
CAN certificate FM	FM16CA0067X	FM16CA0067X
USA marking FM	Class I, Div. 2, Groups A,B,C,D; Class I, Zone 2, AEx nA nC Group IIC; AIS Class I,II,III, Div. 1, Groups A,B,C,D,E,F,G; Class I, Zone 0, [AEx ia] IIC T4 at Ta = 70°C; See Doc. 9146 6 031 001 1	Class I, Div. 2, Groups A,B,C,D; Class I, Zone 2, AEx nA nC Group IIC; AIS Class I,II,III, Div. 1, Groups A,B,C,D,E,F,G; Class I, Zone 0, [AEx ia] IIC T4 at Ta = 70°C; See Doc. 9146 6 031 001 1

Technical Data		
Variant	Number of channels 1	Number of channels 2
Explosion Protection		
CAN marking FM	Class I, Div. 2, Groups A,B,C,D; Class I, Zone 2, Ex nA nC Group IIC; AIS Class I,II,III, Div. 1, Groups A,B,C,D,E,F,G; Class I, Zone 0, [Ex ia] IIC; T4 at Ta = 70°C; See Doc. 9146 6 031 001 1	Class I, Div. 2, Groups A,B,C,D; Class I, Zone 2, Ex nA nC Group IIC; AIS Class I,II,III, Div. 1, Groups A,B,C,D,E,F,G; Class I, Zone 0, [Ex ia] IIC; T4 at Ta = 70°C; See Doc. 9146 6 031 001 1
IECEX gas explosion protection	Ex nA nC [ia Ga] IIC T4 Gc	Ex nA nC [ia Ga] IIC T4 Gc
IECEX dust explosion protection	[Ex ia Da] IIIC	[Ex ia Da] IIIC
IECEX firedamp protection	[Ex ia Ma] I	[Ex ia Ma] I
Certificates	ATEX (BVS), Canada (FM), IECEX (BVS), India (PESO), USA (FM)	ATEX (BVS), Canada (FM), IECEX (BVS), India (PESO), USA (FM)
Ship approval	CCS, DNV GL	CCS, DNV GL
Safety Data		
Max. voltage U_i/V_{oc}	10.5 V	10.5 V
Max. current I_i/I_{sc}	23.4 mA	23.4 mA
Max. power P_o	61.4 mW	61.4 mW
Safety-related maximum voltage	253 V	253 V
Auxiliary Power		
Auxiliary power	24 V DC	24 V DC
Nominal current	55 mA	75 mA
Input		
Input signal	In accordance with EN 60947-5-6 (NAMUR)	In accordance with EN 60947-5-6 (NAMUR)
Input frequency	0.0010 – 20000 Hz	0.0010 – 20000 Hz
Line fault and loss of power signalization	Contact (30 V / 100 mA) closed to ground in case of fault pac-Bus, floating contact (30 V / 100 mA)	Contact (30 V / 100 mA) closed to ground in case of fault pac-Bus, floating contact (30 V / 100 mA)
Ambient Conditions		
Ambient temperature °F	-4°F ... +158°F (Single device) -4°F ... +140°F (Group assembly)	-4°F ... +158°F (Single device) -4°F ... +140°F (Group assembly)
Ambient temperature °C	-20 °C ... +70 °C (Single device) -20 °C ... +60 °C (Group assembly)	-20 °C ... +70 °C (Single device) -20 °C ... +60 °C (Group assembly)
Storage temperature °F	-40°F ... +176°F	-40°F ... +176°F
Storage temperature °C	-40 °C ... +80 °C	-40 °C ... +80 °C
Mounting / Installation		
Mounting type	NS35/15, NS35/7.5 DIN rail	NS35/15, NS35/7.5 DIN rail
Accessories and spare parts see page 216		

07b

Technical Drawings – Subject to Alterations

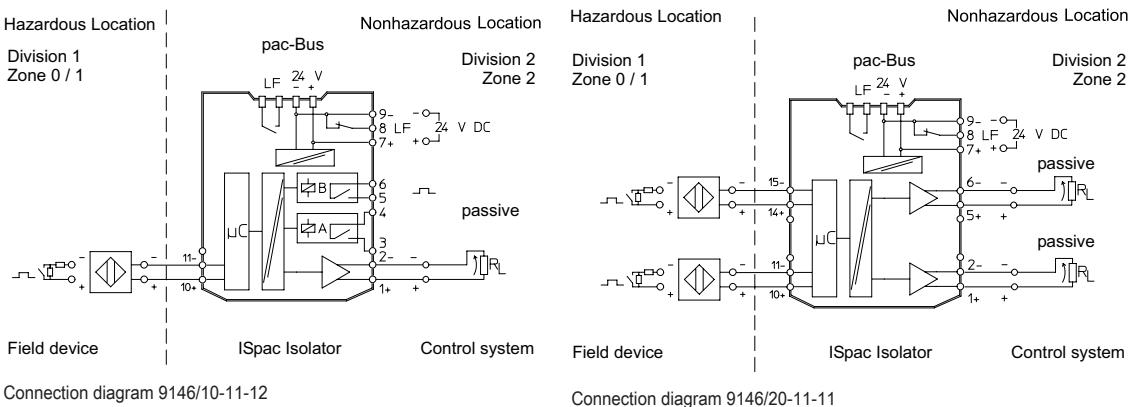

Dimensional drawings see page 217



- Space-saving two-channel variant reduces installation costs
- Easily accessible rotary switch makes adjustment simple
- Can be used up to SIL 2 (IEC 61508)

WebCode **9147A**



07 b

9147 series vibration transducer power supply units connect vibration, acceleration and speed sensors to analytical systems. The measuring signals are galvanically separated when they are transmitted. They are transmitted at frequencies of up to 50 Hz. These units have already been tested with numerous sensors from well-known manufacturers such as Bently Nevada and are in use in systems across the globe.

	NEC® 500 CEC Appendix J					
	Class I		Class II		Class III	
Division	1	2	1	2	1	2
Ex interface	•	•	•	•	•	•
Installation in		•				

	CEC Section 18					
	NEC® 505 Class I			NEC® 506		
Zone	0	1	2	20	21	22
Ex interface	•	•	•			
Installation in			•			

	IECEX / ATEX					
	Zone	0	1	2	20	21
Ex interface	•	•	•	•	•	•
Installation in			•			

Selection Table					
Product variant	Vibration Transducer Supply Unit			Art. No.	Weight lb
Number of channels	Product Type				
1	9147/10-99-10s			212432	0.33
2	9147/20-99-10s			212433	0.46

The order numbers listed in the table are for devices equipped with screw terminals. Variants with a spring clamp terminal are available. Further versions on the Internet r-stahl.com.

Technical Data	
Explosion Protection	
USA certificate FM	FM16US0122X
CAN certificate FM	FM16CA0067X
USA marking FM	Class I, Div. 2, Groups A,B,C,D; Class I, Zone 2, AEx nA Group IIC; AIS Class I,II,III, Div. 1, Groups A,B,C,D,E,F,G; Class I, Zone 0, [AEx ia] IIC; T4 at Ta = 70°C; See Doc. 9147 6 031 001 1
CAN marking FM	Class I, Div. 2, Groups A,B,C,D; Class I, Zone 2, Ex nA Group IIC; AIS Class I,II,III, Div. 1, Groups A,B,C,D,E,F,G; Class I, Zone 0, [Ex ia] IIC; T4 at Ta = 70°C; See Doc. 9147 6 031 001 1
IECEX gas explosion protection	Ex nA [ja Ga] IIC T4 Gc
IECEX dust explosion protection	[Ex ia Da] IIC

Technical Data	
Explosion Protection	
IECEx firedamp protection	[Ex ia Ma] I
Installation	in Zone 2
Further information	see respective certificate and operating instructions
Certificates	ATEX (BVS), Canada (FM), IECEx (BVS), India (PESO), SIL (exida), USA (FM)
Ship approval	CCS, DNV GL
Safety Data	
Max. voltage U_0/V_{oc}	26.3 V
Max. current I_0/I_{sc}	88.3 mA
Max. power P_0	579 mW
Safety-related maximum voltage	253 V
Functional Safety	
SIL	2
Electrical Data	
Output current for 2-wire operation	2.6 / 4.3 / 7.9 mA at -10 V
Output current for 3-wire operation	10 mA at -20 V; 20 mA at -17 V
Auxiliary Power	
Auxiliary power	24 V DC
Power dissipation max.	1.4 W
Input	
Input signal	-20 ... -0.5 V
Input functional range	-24 – 0 V
Input resistance	10 kΩs
Output	
Output signal	-20 to -0.5 V
Signal transmission frequency range	0 – 50 kHz
Ambient Conditions	
Ambient temperature °F	-4°F ... +158°F (Single device) -4°F ... +158°F (Group assembly)
Ambient temperature °C	-20 °C ... +70 °C (Single device) -20 °C ... +70 °C (Group assembly)
Storage temperature °F	-40°F ... +176°F
Storage temperature °C	-40 °C ... +80 °C
Mounting / Installation	
Mounting type	DIN rail (NS35/15, NS35/7.5)
Accessories and spare parts see page 216; Dimensional drawings see page 217	

07b

Technical Drawings – Subject to Alterations

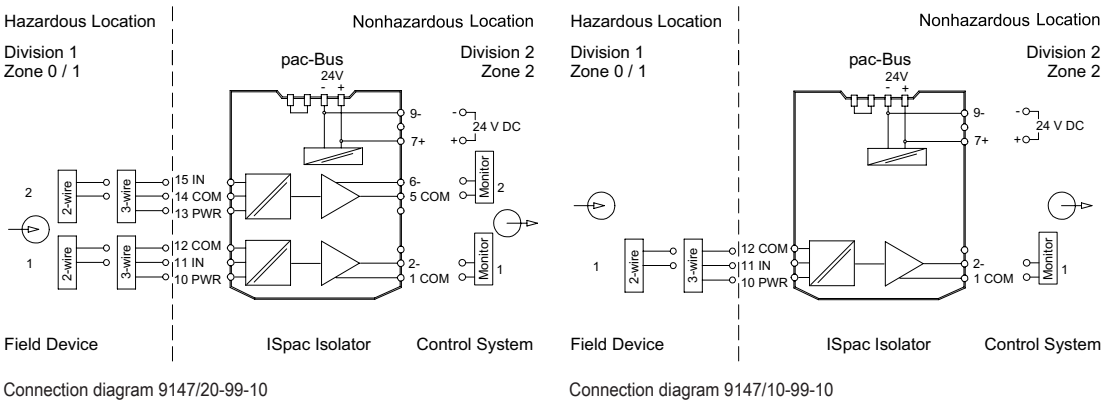



- Can be used universally for two- and three-conductor transmitters and mA sources (four-conductor transmitters)
- High degree of accuracy
- Standard variant can be used up to SIL 2, special variant up to SIL 3 (IEC/EN 61508)

WebCode **9160A**



07 b

9160 series Ex i transmitter power supply units can be used for the intrinsically safe operation of two- and three-conductor transmitters or intrinsically safe mA sources such as four-conductor transmitters. The unit allows HART signals to be transmitted in both directions. The portfolio includes one- and two-channel units and a variant for signal duplication. Special versions are available for higher output voltages and SIL 3.

	NEC® 500 CEC Appendix J						CEC Section 18						IECEX / ATEX					
	Class I		Class II		Class III		NEC® 505 Class I			NEC® 506								
Division	1	2	1	2	1	2	0	1	2	20	21	22	0	1	2	20	21	22
Ex interface	•	•	•	•	•	•	•	•	•				•	•	•	•	•	•
Installation in		•				•			•						•			

Selection Table								
Product variant	Transmitter supply unit							
Number of channels	Input	Output A	Output B	LFD relay	SIL	Product Type	Art. No.	Weight lb
1	0/4 ... 20 mA with HART	0/4 ... 20 mA	–	Yes	2	9160/13-11-11s	214895	0.43
		0/4 ... 20 mA	–	Yes	3	9160/13-11-13s	214897	0.43
		0/4 ... 20 mA	0/4 ... 20 mA (without HART)	Yes	2	9160/19-11-11s	220324	0.43
2	0/4 ... 20 mA with HART	Passive	Passive	No	2	9160/23-10-10s	214903	0.43
		0/4 ... 20 mA	0/4 ... 20 mA	Yes	2	9160/23-11-11s	220322	0.44

LFD – line fault diagnosis
 no – device transmits line fault on the field side via the 4 ... 20 mA signal. Without LED / relay contact.
 yes – device transmits line fault on the field side via the 4 ... 20 mA signal. With LED / relay contact.

The order numbers listed in the table are for devices equipped with screw terminals.

Further versions available at r-stahl.com

Technical Data		
Variant	9160/...-11 9160/...-13	9160/...-10
Explosion Protection		
USA certificate FM	FM16US0122X	FM16US0122X
CAN certificate FM	FM16CA0067X	FM16CA0067X

Technical Data		
Variant	9160/...-11 9160/...-13	9160/...-10
Explosion Protection		
USA marking FM	Class I, Div. 2, Groups A,B,C,D; Class I, Zone 2, AEx nA nC Group IIC; AIS Class I,II,III, Div. 1, Groups A,B,C,D,E,F,G; Class I, Zone 0, [AEx ia] IIC T4 Mounting vertical Ta = 70°C or horizontal Ta = 60°C; See Doc. 91 606 01 31 1	Class I, Div. 2, Groups A,B,C,D; Class I, Zone 2, AEx nA Group IIC; AIS Class I,II,III, Div. 1, Groups A,B,C,D,E,F,G; Class I, Zone 0, [AEx ia] IIC T4 Mounting vertical Ta = 70°C or horizontal Ta = 60°C; See Doc. 91 606 01 31 1
CAN marking FM	Class I, Div. 2, Groups A,B,C,D; Class I, Zone 2, Ex nA nC Group IIC; AIS Class I,II,III, Div. 1, Groups A,B,C,D,E,F,G; Class I, Zone 0, [Ex ia] IIC T4 Mounting vertical Ta = 70°C or horizontal Ta = 60°C; See Doc. 91 606 01 31 1	Class I, Div. 2, Groups A,B,C,D; Class I, Zone 2, Ex nA Group IIC; AIS Class I,II,III, Div. 1, Groups A,B,C,D,E,F,G; Class I, Zone 0, [Ex ia] IIC T4 Mounting vertical Ta = 70°C or horizontal Ta = 60°C; See Doc. 91 606 01 31 1
IECEx gas explosion protection	Ex nA nC [ia Ga] IIC T4 Gc	Ex nA [ia Ga] IIC T4 Gc
IECEx dust explosion protection	[Ex ia Da] IIIC	[Ex ia Da] IIIC
IECEx firedamp protection	[Ex ia Ma] I	[Ex ia Ma] I
Certificates	ATEX (BVS), Brazil (ULB), Canada (FM), IECEx (BVS), India (PESO), Korea (KTL), Russia (Meteorological certificate), SIL (exida), USA (FM)	ATEX (BVS), Brazil (ULB), Canada (FM), IECEx (BVS), India (PESO), Korea (KTL), Russia (Meteorological certificate), SIL (exida), USA (FM)
Ship approval	CCS, DNV GL	CCS, DNV GL
Auxiliary Power		
Auxiliary power	24 V DC	24 V DC
Input		
Input signal	0/4 ... 20 mA with HART	0/4 ... 20 mA with HART
Ex i input supply voltage for transmitter	≥ 16 V at 20 mA (for 2-wire)	≥ 16 V at 20 mA (for 2-wire)
Supply voltage for transmitter	≥ 16 V at 20 mA	≥ 16 V at 20 mA
Output		
Output	0/4 ... 20 mA with HART	Passive with HART
Load resistance R _L	0 ... 600 Ω (terminal 1+ / 2- or 5+ / 6-) 0 ... 379 Ω (terminal 3+ / 2- or 4+ / 6-) (with internal 221 Ω resistor for HART)	
Load resistance R _L max. HART	379 Ω	See characteristic curve
Load R _L max. with resistor	379 Ω	
Load resistance R _L max.	600 Ω	
Load resistance R _L max. note	With internal 221 Ω resistor	
Temperature influence error limits	≤ 0,05 % / 10K	≤ 0,05 % / 10K
Deviation	≤ 0,1 %	≤ 0,1 %
Ambient Conditions		
Ambient temperature °F	-4°F ... +158°F (Single device) -40°F ... +140°F (Group assembly)	-4°F ... +158°F (Single device) -4°F ... +140°F (Group assembly)
Ambient temperature °C	-20 °C ... +70 °C (Single device) -20 °C ... +60 °C (Group assembly)	-20 °C ... +70 °C (Single device) -20 °C ... +60 °C (Group assembly)
Storage temperature °F	-40°F ... +176°F	-40°F ... +176°F
Storage temperature °C	-40 °C ... +80 °C	-40 °C ... +80 °C
Mounting / Installation		
Mounting type	NS35/15, NS35/7.5 DIN rail	NS35/15, NS35/7.5 DIN rail

Technical Drawings – Subject to Alterations

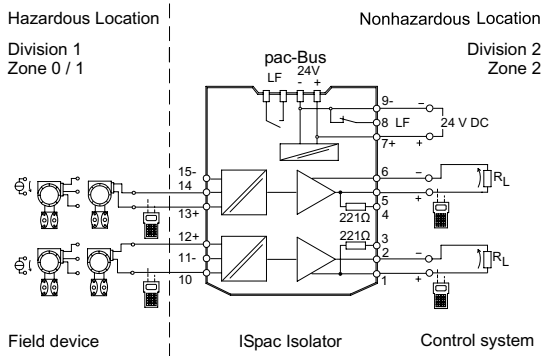

Connection diagram 9160/23-11-11

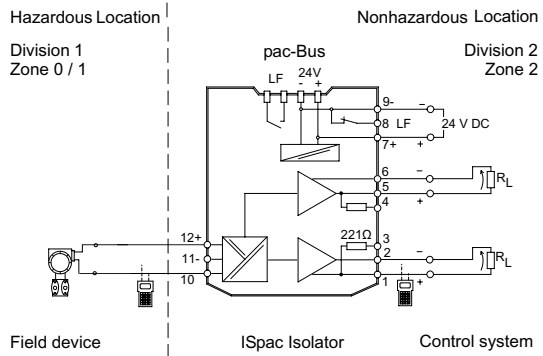

Connection diagram 9160/19-11-11

07 b

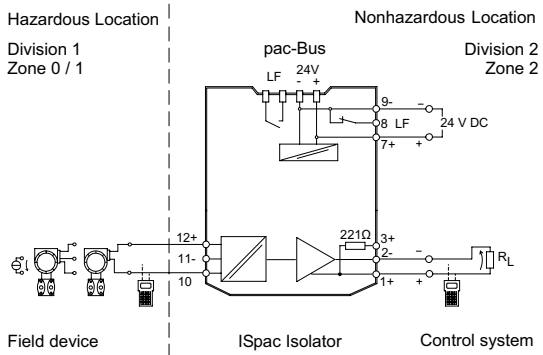

Connection diagram 9160/13-11-13

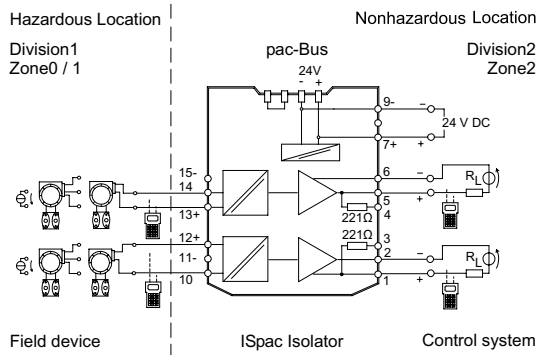

Connection diagram 9160/23-10-10

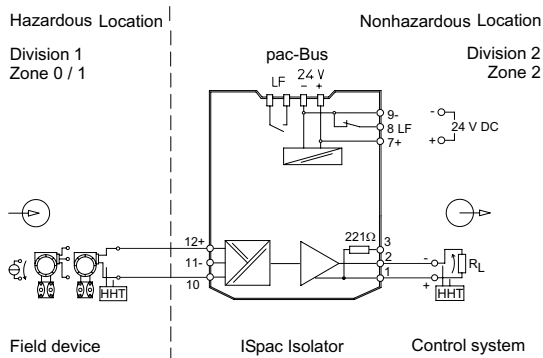

Connection diagram 9160/13-11-11

Load Resistance R_L

Output version (control) 0/4 ... 20 mA passive / sink with HART

Type 9160/..-10-10s

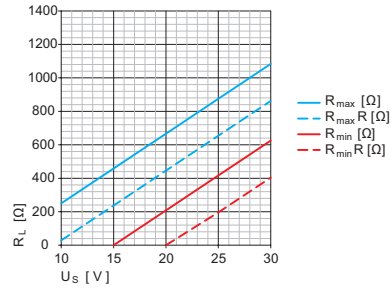

U_S supply voltage
 R_L load resistance
 R_{max} max. load resistance terminals 1, 2 & 5, 6
 R_{min} min. load resistance terminals 1, 2 & 5, 6
 $R_{max R}$ max. load resistance terminals 1, 3 & 4, 6
 $R_{min R}$ min. load resistance terminals 1, 3 & 4, 6

Accessories and spare parts see page 216

Dimensional drawings see page 217

07 b



- Universal use for transmitters and mA sources (4-wire transmitter)
- Slim design – 12.5 mm wide – for one- and two-channel versions
- Can be used for safety levels up to SIL 2 (IEC/EN 61508)

WebCode **9260A**



07 b

Series 9260 Ex i transmitter supply units can be used for the intrinsically safe operation of transmitters or intrinsically safe mA sources such as 4-wire transmitters. The device allows HART signals to be transmitted in both directions. The portfolio includes one- and two-channel devices and a variant for signal duplication.

	NEC® 500 CEC Appendix J						CEC Section 18						IECEX / ATEX					
	Class I		Class II		Class III		NEC® 505 Class I			NEC® 506			Zone		Ex interface		Installation in	
Division	1	2	1	2	1	2	0	1	2	20	21	22	0	1	2	20	21	22
Ex interface	•	•	•	•	•	•	•	•	•				•	•	•	•	•	•
Installation in		•							•						•			

Selection Table						
Output version (control)	0/4 ... 20 mA active / passive with HART					
Number of channels	Input signal	Output A	Output B	Product Type	Art. No.	Weight lb
1	0/4 ... 20 mA with HART	0/4 ... 20 mA	–	9260/13-11-10s	261384 ▲	0.41
Output version (control)	0/4 ... 20 mA active / with HART					
Number of channels	Input signal	Output A	Output B	Product Type	Art. No.	Weight lb
1	0/4 ... 20 mA with HART	0/4 ... 20 mA	0/4 ... 20 mA (without HART)	9260/19-11-10s	261385 ▲	0.43
2	4 ... 20 mA with HART	4 ... 20 mA	4 ... 20 mA	9260/23-11-10s	261386 ▲	0.43

Technical Data			
Variant	9260/13-11-10s	9260/19-11-10s	9260/23-11-10s
Explosion Protection			
USA certificate UL	E81680	E81680	E81680
CAN certificate UL	E81680	E81680	E81680
USA marking UL	Class I, Div. 2, Groups A,B,C,D; Class I, Zone 2, Ex nA Group IIC; AIS Class Class I,II,III, Div. 1, Groups A,B,C,D,E,F,G; Class I, Zone 0, [Ex ia] IIC; T4 any mounting position Ta = 60°C; See Doc. 9260 6 031 001 3	Class I, Div. 2, Groups A,B,C,D; Class I, Zone 2, Ex nA Group IIC; AIS Class Class I,II,III, Div. 1, Groups A,B,C,D,E,F,G; Class I, Zone 0, [Ex ia] IIC; T4 any mounting position Ta = 60°C; See Doc. 9260 6 031 001 3	Class I, Div. 2, Groups A,B,C,D; Class I, Zone 2, Ex nA Group IIC; AIS Class Class I,II,III, Div. 1, Groups A,B,C,D,E,F,G; Class I, Zone 0, [Ex ia] IIC; T4 any mounting position Ta = 60°C; See Doc. 9260 6 031 001 3

Technical Data			
Variant	9260/13-11-10s	9260/19-11-10s	9260/23-11-10s
Explosion Protection			
CAN marking UL	Class I, Div. 2, Groups A,B,C,D; Class I, Zone 2, Ex nA Group IIC; AIS Class Class I,II,III, Div. 1, Groups A,B,C,D,E,F,G; Class I, Zone 0, [Ex ia] IIC; T4 any mounting position Ta = 60°C; See Doc. 9260 6 031 001 3	Class I, Div. 2, Groups A,B,C,D; Class I, Zone 2, Ex nA Group IIC; AIS Class Class I,II,III, Div. 1, Groups A,B,C,D,E,F,G; Class I, Zone 0, [Ex ia] IIC; T4 any mounting position Ta = 60°C; See Doc. 9260 6 031 001 3	Class I, Div. 2, Groups A,B,C,D; Class I, Zone 2, Ex nA Group IIC; AIS Class Class I,II,III, Div. 1, Groups A,B,C,D,E,F,G; Class I, Zone 0, [Ex ia] IIC; T4 any mounting position Ta = 60°C; See Doc. 9260 6 031 001 3
IECEx gas explosion protection	Ex nA [ia Ga] IIC T4 Gc	Ex nA [ia Ga] IIC T4 Gc	Ex nA [ia Ga] IIC T4 Gc
IECEx dust explosion protection	[Ex ia Da] IIIC	[Ex ia Da] IIIC	[Ex ia Da] IIIC
IECEx firedamp protection	[Ex ia Ma] I		
Certificates	ATEX (BVS), Canada / USA (UL), IECEx (BVS), SIL (BVS)	ATEX (BVS), Canada / USA (UL), IECEx (BVS), SIL (BVS)	ATEX (BVS), Canada / USA (UL), IECEx (BVS), SIL (BVS)
Ship approval	DNV GL	DNV GL	DNV GL
Safety Data			
Max. voltage $U_{J/V_{sc}}$	25.2 V	25.2 V	25.2 V
Max. current I_{sc}	93 mA	93 mA	93 mA
Max. power P_o	587 mW	587 mW	587 mW
Safety-related maximum voltage	253 V AC	253 V AC	253 V AC
Functional Safety			
SIL	2	2	2
Electrical Data			
LFD relay	No	No	No
Input			
Input function	Isolation amplifier Transmitter power unit	Isolation amplifier Transmitter power unit	Transmitter power unit
Input signal	0/4 ... 20 mA with HART	0/4 ... 20 mA with HART	4 ... 20 mA with HART
Supply voltage for transmitter	≥ 16 V at 20 mA	≥ 16 V at 20 mA	≥ 16 V at 20 mA
Output			
Load resistance R_L max.	1000 Ω	450 Ω	450 Ω
Deviation	≤ 0,1 %	≤ 0,1 %	≤ 0,1 %
Temperature influence error limits	< 0.1% / 10 K	< 0.1% / 10 K	< 0.1% / 10 K
Ambient Conditions			
Ambient temperature °F	-4°F ... +140°F	-4°F ... +140°F	-4°F ... +140°F
Ambient temperature °C	-20 °C ... +60 °C	-20 °C ... +60 °C	-20 °C ... +60 °C
Storage temperature °F	-40°F ... +176°F	-40°F ... +176°F	-40°F ... +176°F
Storage temperature °C	-40 °C ... +80 °C	-40 °C ... +80 °C	-40 °C ... +80 °C
Mounting / Installation			
Mounting type	NS35/15, NS35/7.5 DIN rail	NS35/15, NS35/7.5 DIN rail	NS35/15, NS35/7.5 DIN rail
Accessories and spare parts see page 216			

07b

Technical Drawings – Subject to Alterations

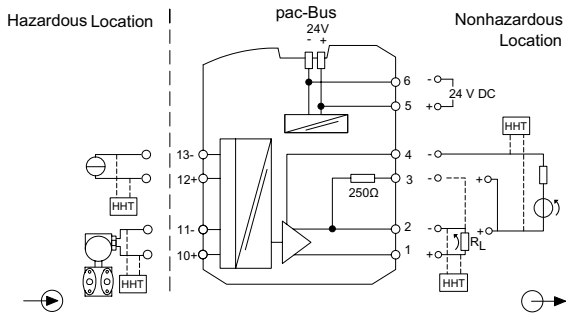

Connection diagram 9260/13-11-10

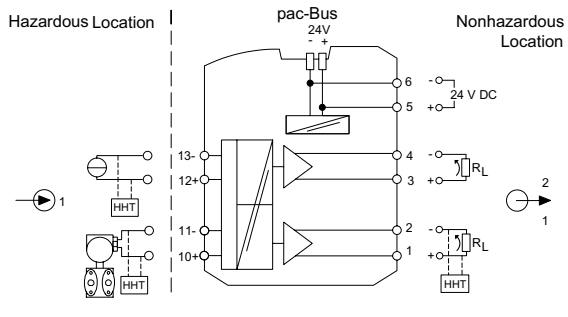

Connection diagram 9260/19-11-10

07 b

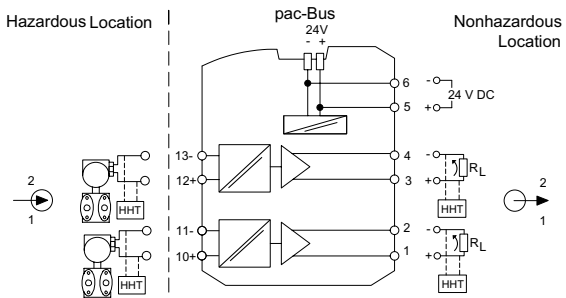

Connection diagram 9260/23-11-10

Dimensional drawings see page 217



- Universal use for transmitters and mA sources (4-wire transmitters) with two configurable limit values and one 4 to 20 mA output
- Bidirectional HART transmission
- Can be used up to SIL 2 (IEC/EN 61508)

WebCode **9162A**



9162 series Ex i transmitter power supply units with limit values can be used for the intrinsically safe operation of two- and three-conductor transmitters or for connecting to intrinsically safe mA sources. Two limit values can be easily set using the "ISpac Wizard" software. If the value exceeds or falls below these limit values, these units will issue an alert. A wire-breakage and short-circuit monitoring system provides increased availability.

07 b

	NEC® 500 CEC Appendix J					
	Class I		Class II		Class III	
Division	1	2	1	2	1	2
Ex interface	•	•	•	•	•	•
Installation in		•				•

	CEC Section 18					
	NEC® 505 Class I			NEC® 506		
Zone	0	1	2	20	21	22
Ex interface	•	•	•			
Installation in			•			

	IECEX / ATEX					
	Zone	0	1	2	20	21
Ex interface	•	•	•	•	•	•
Installation in			•			

Selection Table						
Number of channels	1					
Input	Output	Limit contact (per channel)	Product Type	Art. No.	Weight lb	
4 ... 20 mA with HART	4 ... 20 mA with HART	2 NOs	9162/13-11-14s	238251	0.5	

The order numbers listed in the table are for devices equipped with screw terminals. Further versions on the Internet r-stahl.com.

Technical Data	
Explosion Protection	
USA certificate FM	FM16US0122X
CAN certificate FM	FM16CA0067X
USA marking FM	Class I, Div. 2, Groups A,B,C,D; Class I, Zone 2, AEx nA nC Group IIC; AIS Class I,II,III, Div. 1, Groups A,B,C,D,E,F,G; Class I, Zone 0, [AEx ia] IIC; T4 at Ta = 70°C; See Doc. 9162 6 031 001 1
CAN marking FM	Class I, Div. 2, Groups A,B,C,D; Class I, Zone 2, Ex nA nC Group IIC; AIS Class I,II,III, Div. 1, Groups A,B,C,D,E,F,G; Class I, Zone 0, [Ex ia] IIC; T4 at Ta = 70°C; See Doc. 9162 6 031 001 1
IECEX gas explosion protection	Ex nA nC [ia Ga] IIC T4 Gc
IECEX dust explosion protection	[Ex ia Da] IIC

Technical Data

Explosion Protection	
Certificates	ATEX (BVS), Canada (FM), IECEx (BVS), India (PESO), SIL (exida), USA (FM)
Ship approval	CCS, DNV GL
Safety Data	
Max. voltage U_0/V_{oc}	27 V
Max. current I_0/I_{sc}	87.9 mA
Max. power P_0	574 mW
Safety-related maximum voltage	253 V
Functional Safety	
SIL	2
Electrical Data	
Limiting values configuration	using ISpac wizard (V3.04 and following)
Auxiliary Power	
Auxiliary power	24 V DC
Nominal current	85 mA
Input	
Input	4 ... 20 mA with HART
Supply voltage for transmitter	≥ 16 V at 20 mA
Line fault and loss of power signalization	Contact (30 V / 100 mA) closed to ground in case of fault pac-Bus, floating contact (30 V / 100 mA)
Output	
Output signal	4 ... 20 mA with HART
Load resistance R_L	0 ... 600 Ω (terminal 1+ / 2-)
Switching voltage limiting values	$\leq \pm 30$ V
Switching current limiting values	≤ 170 mA
Ambient Conditions	
Ambient temperature °F	-40°F ... +158°F (Single device) -40°F ... +140°F (Group assembly)
Ambient temperature °C	-40 °C ... +70 °C (Single device) -40 °C ... +60 °C (Group assembly)
Storage temperature °F	-40°F ... +176°F
Storage temperature °C	-40 °C ... +80 °C
Mounting / Installation	
Mounting type	NS35/15, NS35/7.5 DIN rail

Accessories and spare parts see page 216

Technical Drawings – Subject to Alterations

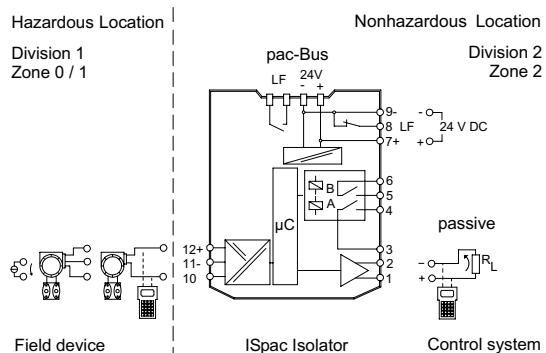

Connection diagram 9162/13-11-14

Dimensional drawings see page 217



- For installation in Class I, Div. 1 hazardous areas
- Intrinsically safe (Ex i) input
- Space-saving, 12-mm wide design

WebCode **9164A**



The 9164 series mA isolating repeater allows two 4 to 20 mA signal sources to be coupled. For example, it allows four-conductor transmitters to be connected to I/O cards designed to be operated with two conductors. The use of this device therefore saves costs by eliminating the need for additional I/O cards or can be used as the only solution for I/O cards that only operate with two conductors.

07b

	NEC® 500 CEC Appendix J					
	Class I		Class II		Class III	
Division	1	2	1	2	1	2
Ex interface	•		•		•	
Installation in	•		•		•	

	CEC Section 18					
	NEC® 505 Class I			NEC® 506		
Zone	0	1	2	20	21	22
Ex interface	•					
Installation in		•				

	IECEX / ATEX					
	Zone	0	1	2	20	21
Ex interface	•	•	•	•	•	•
Installation in		•	•			

Selection Table					
Number of channels	1				
Input	Output		Product Type	Art. No.	Weight lb
Ex i: 4 to 20 mA HART (sink)	Ex i: passive HART (sink)		9164/13-20-08	224364	0.2
The transmission of the HART signal can be deactivated by means of a DIP switch.					

Technical Data	
Explosion Protection	
USA certificate FM	FM16US0122X
CAN certificate FM	FM16CA0067X
USA marking FM	IS for Class I,II,III, Div. 1, Groups A,B,C,D,E,F,G, T4; Class I, Zone 0, AEx ia IIC T4; with connections for Class I,II,III, Div. 1, Groups A,B,C,D,E,F,G; Class I, Zone 0, AEx [ia] IIC; See Doc. 91 646 01 31 1
CAN marking FM	IS for Class I,II,III, Div. 1, Groups A,B,C,D,E,F,G, T4; Class I, Zone 0, Ex ia IIC T4; with connections for Class I,II,III, Div. 1, Groups A,B,C,D,E,F,G; Class I, Zone 0, Ex [ia] IIC; See Doc. 91 646 01 31 1
IECEX gas explosion protection	Ex ib [ia Ga] IIC T4 Gb
IECEX dust explosion protection	[Ex ia Da] IIIC
Certificates	ATEX (BVS), Canada (FM), EAC (TehnoP), IECEX (BVS), Russia (Meteorological certificate), SIL (exida), USA (FM)
Ship approval	CCS, DNV GL

07 b

Technical Data	
Safety Data	
Max. voltage U_i	30 V
Max. current I_i	150 mA
Max. power P_i	1000 mW
Functional Safety	
SIL	2
Auxiliary Power	
Auxiliary power	Without
Input	
Input signal	3,8 ... 20,5 mA with HART
Output	
Output signal	3.8 – 20.5 mA with HART
Ambient Conditions	
Ambient temperature °F	-40°F ... +167°F
Ambient temperature °C	-40 °C ... +75 °C
Storage temperature °F	-40°F ... +176°F
Storage temperature °C	-40 °C ... +80 °C
Mounting / Installation	
Mounting type	NS35/15, NS35/7.5 DIN rail

Technical Drawings – Subject to Alterations

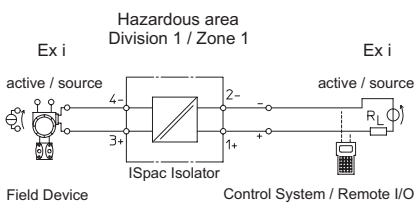

Connection Diagram 9164/13-2.-08

Dimensional Drawings (All Dimensions in mm [inches]) – Subject to Alterations

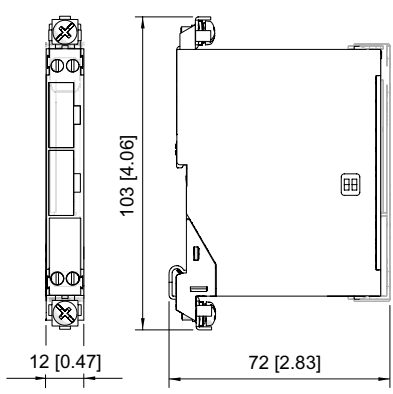



- Compact one- and two-channel Ex i output isolating repeater
- Wire-breakage and short-circuit monitoring system, which can be disconnected and features a signalling contact
- Can be used up to SIL 2 (IEC/EN 61508)

WebCode **9165A**



9165 series Ex i isolating repeaters can be used for the intrinsically safe operation of control valves, I/P transducers or indicators. They transmit superimposed HART communication signals in both directions. The input, output and auxiliary power are galvanically separated from one another. The two channels in the two-channel variants are galvanically separated from one another.

07 b

	NEC® 500 CEC Appendix J					
	Class I		Class II		Class III	
Division	1	2	1	2	1	2
Ex interface	•	•	•	•	•	•
Installation in		•				

	CEC Section 18 NEC® 505 NEC® 506					
	Class I					
Zone	0	1	2	20	21	22
Ex interface	•	•	•			
Installation in			•			

	IECEx / ATEX					
	Zone	0	1	2	20	21
Ex interface		•	•	•	•	•
Installation in						

Selection Table						
Number of channels	1					
Input signal	Output signal	LFD relay	Product Type	Art. No.	Weight lb	
0/4 ... 20 mA with HART	0/4 ... 20 mA with HART	Yes	9165/16-11-11s	201270 ▲	0.4	
Number of channels	2					
Input signal	Output signal	LFD relay	Product Type	Art. No.	Weight lb	
0/4 ... 20 mA with HART	0/4 ... 20 mA with HART	Yes	9165/26-11-11s	201272 ▲	0.42	

LFD - line fault diagnosis
 no - device transmits field-side line fault via 4 ... 20 mA signal and via LED. Function cannot be deactivated.
 yes - device transmits field-side line fault via 4 ... 20 mA signal via LED and relay contact.

The order numbers listed in the table are for devices equipped with screw terminals.
 Further versions on the Internet r-stahl.com.

Technical Data	
Explosion Protection	
USA certificate FM	FM16US0122X
CAN certificate FM	FM16CA0067X
USA marking FM	Class I, Div. 2, Groups A,B,C,D; Class I, Zone 2, AEx nA nC Group IIC; AIS Class I,II,III, Div. 1, Groups A,B,C,D,E,F,G; Class I, Zone 0, [AEx ia] IIC; T4 at Ta = 70°C; See Doc. 91 656 01 31 1

Technical Data

Explosion Protection

CAN marking FM	Class I, Div. 2, Groups A,B,C,D; Class I, Zone 2, Ex nA nC Group IIC; AIS Class I,II,III, Div. 1, Groups A,B,C,D,E,F,G; Class I, Zone 0, [Ex ia] IIC; T4 at Ta = 70°C; See Doc. 91 656 01 31 1
IECEX gas explosion protection	Ex nA nC [ia Ga] IIC T4 Gc
IECEX dust explosion protection	[Ex ia Da] IIIC
Certificates	ATEX (BVS), Canada (FM), IECEX (BVS), India (PESO), Korea (KTL), Russia (Meteorological certificate), SIL (exida), USA (FM)
Ship approval	CCS, DNV GL

Safety Data

Max. voltage U_0/V_{oc}	25.6 V
Max. current I_0/I_{sc}	96 mA
Max. power P_0	605 mW
Safety-related maximum voltage	253 V

Output

Load resistance R_L	0 ... 800 Ω
-----------------------	--------------------

Ambient Conditions

Ambient temperature °F	-4°F ... +158°F (Single device) -4°F ... +140°F (Group assembly)
Ambient temperature °C	-20 °C ... +70 °C (Single device) -20 °C ... +60 °C (Group assembly)
Storage temperature °F	-40°F ... +176°F
Storage temperature °C	-40 °C ... +80 °C

Mounting / Installation

Mounting type	DIN rail (NS35/15, NS35/7.5)
---------------	------------------------------

Accessories and spare parts see page 216

Technical Drawings – Subject to Alterations

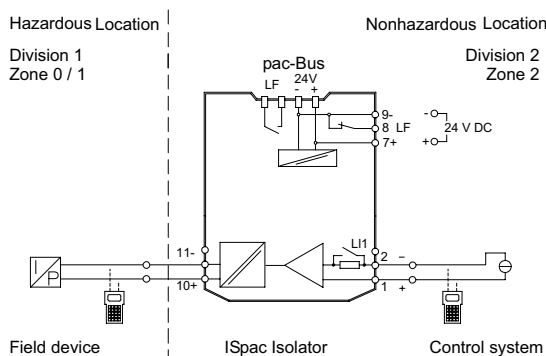

Connection diagram 9165/16-11-11

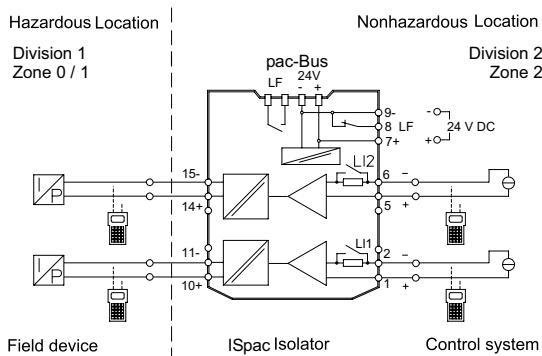

Connection diagram 9165/26-11-11

Dimensional drawings see page 217



- Compact one- and two-channel Ex i output isolating repeater
- Space savings due to a slim design – 12.5 mm wide
- Can be used up to SIL 2 (IEC/EN 61508)

WebCode **9265A**



9265 series Ex i isolating repeaters can be used for the intrinsically safe operation of control valves, I/P transducers or indicators. They transmit superimposed HART communication signals in both directions. The input, output and auxiliary power are galvanically separated from one another. The two channels in the two-channel variants are galvanically separated from one another.

07 b

	NEC® 500 CEC Appendix J					
	Class I		Class II		Class III	
Division	1	2	1	2	1	2
Ex interface	•	•	•	•	•	•
Installation in		•				

	CEC Section 18					
	NEC® 505 Class I			NEC® 506		
Zone	0	1	2	20	21	22
Ex interface	•	•	•			
Installation in			•			

	IECEx / ATEX					
	Zone	0	1	2	20	21
Ex interface	•	•	•	•	•	•
Installation in			•			

Selection Table						
Product variant	Isolating repeater					
Number of channels	Input signal	Output signal	LFD relay	Product Type	Art. No.	Weight lb
1	0/4 ... 20 mA with HART	0/4 ... 20 mA with HART	No	9265/16-11-10s	261403	0.41
2	0/4 ... 20 mA with HART	0/4 ... 20 mA with HART	No	9265/26-11-10s	261404	0.43

The order numbers listed in the table are for devices equipped with screw terminals. Further versions on the Internet r-stahl.com.

Technical Data		
Variant	9265/16-11-10s	9165/26-11-10s
Explosion Protection		
USA certificate UL	pending	pending
CAN certificate UL	pending	pending
IECEx gas explosion protection	Ex ec [ia Ga] IIC T4 Gc	Ex ec [ia Ga] IIC T4 Gc
IECEx dust explosion protection	[Ex ia Da] IIIC	[Ex ia Da] IIIC
IECEx firedamp protection	Ex [Ex ia Ma] I	Ex [Ex ia Ma] I
Ship approval	DNV GL	
Safety Data		
Max. voltage U_0/V_{oc}	25.2 V	25.2 V
Max. current I_0/I_{sc}	93 mA	93 mA
Max. power P_0	587 mW	587 mW

07 b

Technical Data		
Variant	9265/16-11-10s	9165/26-11-10s
Safety Data		
Safety-related maximum voltage	253 V	253 V
Input		
Input	0/4 ... 20 mA with HART	0/4 ... 20 mA with HART
Output		
Output	0/4 ... 20 mA with HART	0/4 ... 20 mA with HART
Load resistance R_L max.	700 Ω	700 Ω
Ambient Conditions		
Ambient temperature °F	-40°F ... +158°F	-40°F ... +158°F
Ambient temperature °C	-40 °C ... +70 °C	-40 °C ... +70 °C
Storage temperature °F	-40°F ... +185°F	-40°F ... +185°F
Storage temperature °C	-40 °C ... +85 °C	-40 °C ... +85 °C
Mounting / Installation		
Mounting type	NS35/15, NS35/7.5 DIN rail	NS35/15, NS35/7.5 DIN rail
Connection type	Screw terminal	Screw terminal
Accessories and spare parts see page 216		

Technical Drawings – Subject to Alterations

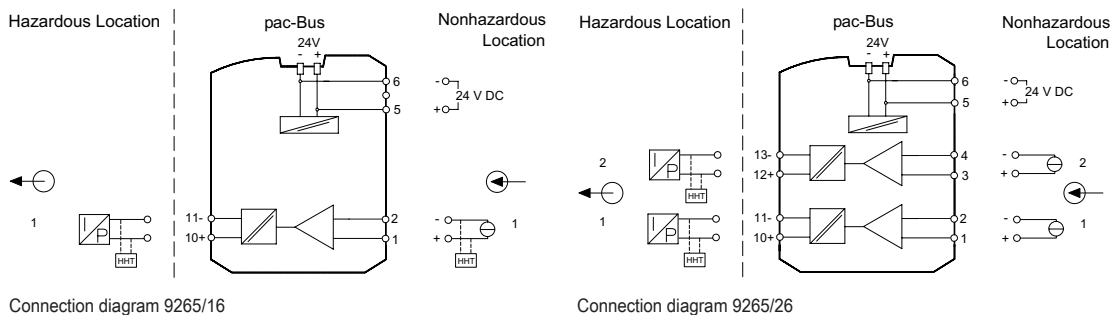

Connection diagram 9265/16

Connection diagram 9265/26

Dimensional drawings see page 217



- Compact, loop-powered one- and two- channel Ex i output isolating repeater
- Suitable for fire and gas detectors
- Can be used up to SIL 3 (IEC 61508)

WebCode **9167A**



9167 series Ex i isolating repeaters operate without auxiliary power and can be used for the intrinsically safe operation of control valves, I/P transducers, analogue indicators and fire or gas detectors, for example. They have one or two channels. They transmit superimposed HART communication signals in both directions.

07 b

	NEC® 500 CEC Appendix J					
	Class I		Class II		Class III	
Division	1	2	1	2	1	2
Ex interface	•	•	•	•	•	•
Installation in		•				

	CEC Section 18					
	NEC® 505			NEC® 506		
	Class I					
Zone	0	1	2	20	21	22
Ex interface	•	•	•			
Installation in			•			

	IECEx / ATEX					
	Zone	0	1	2	20	21
Ex interface		•	•	•	•	•
Installation in			•			

Selection Table						
Product variant	Isolating Repeater Loop Powered					
Number of channels	Max. voltage U_d/V_{dc}	Max. current I_d/I_{dc}	Max. power P_o	Product Type	Art. No.	Weight lb
1	15.7 V	60 mA	233 mW	9167/11-11-00s	160238	0.35
	25 V	99 mA	613 mW	9167/13-11-00s	160244 ▲	0.35
2	25 V	99 mA	613 mW	9167/23-11-00s	160247 ▲	0.4

The order numbers listed in the table are for devices equipped with screw terminals. Further versions on the Internet r-stahl.com.

Technical Data		
Variant	9167/11-11-00	9167/13-11-00
Explosion Protection		
USA certificate FM	FM16US0122X	FM16US0122X
USA certificate UL	E81680V1S7	E81680V1S7
CAN certificate FM	FM16CA0067X	FM16CA0067X
CAN certificate UL	E81680V1S7	E81680V1S7
USA marking FM	Class I, Div. 2, Groups A,B,C,D; Class I, Zone 2, Group IIC; AIS Class I,II,III, Div. 1, Groups A,B,C,D,E,F,G; Class I, Zone 0, [AEx ia] IIC; T4 at Ta = 70°C; See Doc. 91 676 01 31 1	Class I, Div. 2, Groups A,B,C,D; Class I, Zone 2, Group IIC; AIS Class I,II,III, Div. 1, Groups A,B,C,D,E,F,G; Class I, Zone 0, [AEx ia] IIC; T4 at Ta = 70°C; See Doc. 91 676 01 31 1

Technical Data

Variant	9167/11-11-00	9167/3-11-00
Explosion Protection		
USA marking UL	providing intrinsically safe circuits for use in Class I, Groups A,B,C,D; Class II, Groups E,F,G; Class III; See Doc. 91 676 01 31 3	providing intrinsically safe circuits for use in Class I, Groups A,B,C,D; Class II, Groups E,F,G; Class III; See Doc. 91 676 01 31 3
CAN marking FM	Class I, Div. 2, Groups A,B,C,D; Class I, Zone 2, Group IIC; AIS Class I,II,III, Div. 1, Groups A,B,C,D,E,F,G; Class I, Zone 0, [Ex ia] IIC; T4 at Ta = 70°C; See Doc. 91 676 01 31 1	Class I, Div. 2, Groups A,B,C,D; Class I, Zone 2, Group IIC; AIS Class I,II,III, Div. 1, Groups A,B,C,D,E,F,G; Class I, Zone 0, [Ex ia] IIC; T4 at Ta = 70°C; See Doc. 91 676 01 31 1
CAN marking UL	providing intrinsically safe circuits for use in Class I, Groups A,B,C,D; Class II, Groups E,F,G; Class III; See Doc. 91 676 01 31 3	providing intrinsically safe circuits for use in Class I, Groups A,B,C,D; Class II, Groups E,F,G; Class III; See Doc. 91 676 01 31 3
IECEX gas explosion protection	Ex nA [ja Ga] IIC T4 Gc	Ex nA [ja Ga] IIC T4 Gc
IECEX dust explosion protection	[Ex ia Da] IIIC	[Ex ia Da] IIIC
Certificates	ATEX (BVS), Canada / USA (UL), Canada (FM), IECEx (BVS), India (PESO), Russia (Meteorological certificate), SIL (exida), USA (FM)	ATEX (BVS), Canada / USA (UL), Canada (FM), IECEx (BVS), India (PESO), Russia (Meteorological certificate), SIL (exida), USA (FM)
Ship approval	CCS, DNV GL	CCS, DNV GL
Auxiliary Power		
Auxiliary power	Without	Without
Input		
Input signal	0/4 ... 20 mA with HART	0/4 ... 20 mA with HART
Input functional range	0 – 40 mA	0 – 40 mA
Internal resistance R _i at 20mA	410 Ω	380 Ω
Internal resistance R _i at 40mA	360 Ω	330 Ω
Voltage drop additional	1 V	1 V
Output		
Output signal	0/4 ... 20 mA with HART	0/4 ... 20 mA with HART
Output functional range	0 – 40 mA	0 – 40 mA
Load resistance R _L max.	360 Ω	800 Ω
Open-circuit voltage U _o	15,7 V	25 V
Output short-circuit current	≤ 60 mA	≤ 60 mA
Average measurement fault	0,35%	0,35%
Temperature influence error limits	≤ 0.1% / 10 K	≤ 0.1% / 10 K
Ambient Conditions		
Ambient temperature °F	-4°F ... +158°F (Single device) (Group assembly)	-4°F ... +158°F (Single device) -4°F ... +140°F (Group assembly)
Ambient temperature °C	-20 °C ... +70 °C (Single device) -20 °C ... +60 °C (Group assembly)	-20 °C ... +70 °C (Single device) -20 °C ... +60 °C (Group assembly)
Storage temperature °F	-40°F ... +176°F	-40°F ... +176°F
Storage temperature °C	-40 °C ... +80 °C	-40 °C ... +80 °C
Mounting / Installation		
Mounting type	DIN rail (NS35/15, NS35/7.5)	DIN rail (NS35/15, NS35/7.5)
Accessories and spare parts see page 216; Dimensional drawings see page 217		

07 b

Technical Drawings – Subject to Alterations

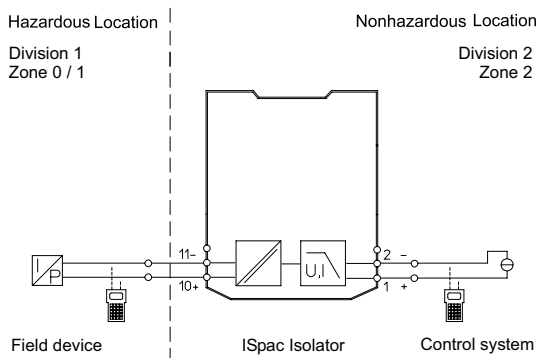

Connection diagram 9167/1

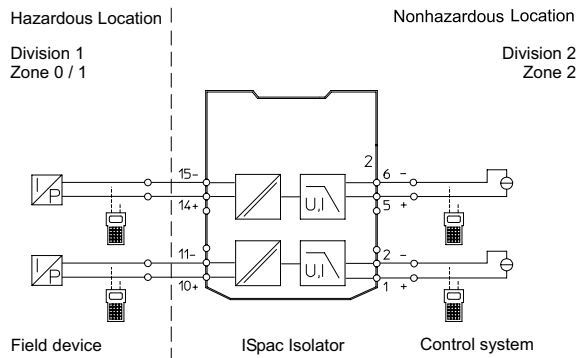

Connection diagram 9167/2

07b



- Can be used up to SIL 2 (IEC/EN 61508)
- Wire-breakage and short-circuit monitoring system, which can be disconnected and issues alerts
- Optional line error transparency: The device notifies the control system directly of any field-side line faults via the signal output.

WebCode **9170A**



07 b

9170 series Ex i switching repeaters can be used for operating contacts, NAMUR proximity sensors or opto-couplers. Models are available with one or two channels. The intrinsically safe digital input is always galvanically separated from the output and auxiliary power. The channels in the two-channel devices are galvanically separated. The devices transmit frequencies of up to 10 kHz, and the output signal can be inverted.

	NEC® 500 CEC Appendix J						CEC Section 18 NEC® 505 NEC® 506						IECEX / ATEX					
	Class I		Class II		Class III		Class I			Class I								
Division	1	2	1	2	1	2	0	1	2	20	21	22	0	1	2	20	21	22
Ex interface	•	•	•	•	•	•	•						•	•	•	•	•	•
Installation in		•*						•						•				

* restrictions, refer to certificate

Selection Table						
Output version (control)		Electronic (35 V / 50 mA)				
Number of channels	Auxiliary power	Output	Product Type	Art. No.	Weight lb	
2	24 V DC	1 electronic output	9170/21-14-11s	203152	0.4	
Output version (control)		Electronic (35 V / 50 mA) with LFT (line fault transparency)				
Number of channels	Auxiliary power	Output	Product Type	Art. No.	Weight lb	
2	24 V DC	1 LFT electronic output	9170/21-14-12s	203153	0.4	
Output version (control)		Power relay (250 V / 4 A)				
Number of channels	Auxiliary power	Output	Product Type	Art. No.	Weight lb	
1	24 V DC	1 change-over contact - power relay	9170/11-12-11s	203285	0.4	
	110 – 230 V AC	2 change-over contacts - power relay	9170/11-13-21s	203294 ▲	0.4	
2	24 V DC	1 change-over contact - power relay	9170/21-12-11s	203147	0.5	
	110 – 230 V AC	1 change-over contact - power relay	9170/21-12-21s	203281 ▲	0.5	
Output version (control)		Signal relay (125 V / 1 A)				
Number of channels	Auxiliary power	Output	Product Type	Art. No.	Weight lb	
1	24 V DC	2 change-over contacts - signal relay	9170/11-11-11s	203283	0.4	
2	24 V DC	1 change-over contact - signal relay	9170/21-10-11s	203143	0.5	
		2 NO - signal relays	9170/21-11-11s	203145	0.5	

LFT - line fault transparency
Device signals line fault on field side to the control directly via the signal output.

The order numbers listed in the table are for devices equipped with screw terminals.
Further versions on the Internet r-stahl.com.

Technical Data			
Variant	Electronic (35 V / 50 mA)	Power relay (250 V / 4 A)	Signal relay (125 V / 1 A)
Explosion Protection			
USA certificate FM	FM16US0122X	FM16US0122X	FM16US0122X
CAN certificate FM	FM16CA0067X	FM16CA0067X	FM16CA0067X
USA marking FM	Class I, Div. 2, Groups A,B,C,D; Class I, Zone 2, Group IIC; AIS Class I,II,III, Div. 1, Groups A,B,C,D,E,F,G; Class I, Zone 0, [AEx ia] IIC; T4 at Ta = 70°C; See Doc. 91 706 02 31 1	AIS Class I,II,III, Div. 1, Groups A,B,C,D,E,F,G; Class I, Zone 0, [AEx ia] IIC; T4 at Ta = 70°C; See Doc. 91 706 02 31 1	Class I, Div. 2, Groups A,B,C,D; Class I, Zone 2, Group IIC; AIS Class I,II,III, Div. 1, Groups A,B,C,D,E,F,G; Class I, Zone 0, [AEx ia] IIC; T4 at Ta = 70°C; See Doc. 91 706 02 31 1
CAN marking FM	Class I, Div. 2, Groups A,B,C,D; Class I, Zone 2, Group IIC; AIS Class I,II,III, Div. 1, Groups A,B,C,D,E,F,G; Class I, Zone 0, [Ex ia] IIC; T4 at Ta = 70°C; See Doc. 91 706 02 31 1	AIS Class I,II,III, Div. 1, Groups A,B,C,D,E,F,G; Class I, Zone 0, [Ex ia] IIC; T4 at Ta = 70°C; See Doc. 91 706 02 31 1	Class I, Div. 2, Groups A,B,C,D; Class I, Zone 2, Group IIC; AIS Class I,II,III, Div. 1, Groups A,B,C,D,E,F,G; Class I, Zone 0, [Ex ia] IIC; T4 at Ta = 70°C; See Doc. 91 706 02 31 1
IECEX gas explosion protection	Ex nA nC [ia Ga] IIC T4 Gc	Ex [Ex ia Ga] IIC	Ex nA nC [ia Ga] IIC T4 Gc
IECEX dust explosion protection	[Ex ia Da] IIIC	[Ex ia Da] IIIC	[Ex ia Da] IIIC
Certificates	ATEX (BVS), Brazil (ULB), Canada (FM), IECEX (BVS), India (PESO), Korea (KGS), SIL (exida), USA (FM)	ATEX (BVS), Brazil (ULB), Canada (FM), IECEX (BVS), India (PESO), Korea (KGS), SIL (exida), USA (FM)	ATEX (BVS), Brazil (ULB), Canada (FM), IECEX (BVS), India (PESO), Korea (KGS), SIL (exida), USA (FM)
Ship approval	CCS, DNV GL	CCS, DNV GL	CCS, DNV GL
Installation	in Zone 2, Division 2 and in the safe area	in safe area	in Zone 2, Division 2 and in the safe area
Notes	see respective certificate and operating instructions		
Safety Data			
Max. voltage U_0/V_{oc}	9.6 V	9.6 V	9.6 V
Max. current I_0/I_{sc}	10 mA	10 mA	10 mA
Max. power P_0	24 mW	24 mW	24 mW
Safety-related maximum voltage	253 V	253 V	253 V
Functional Safety			
SIL	2	2	2
Input			
Input signal	In accordance with EN 60947-5-6 (NA-MUR)	In accordance with EN 60947-5-6 (NA-MUR)	In accordance with EN 60947-5-6 (NA-MUR)
Input for open-circuit voltage U_a	8,2 V	8,2 V	8,2 V
Short-circuit current	≤ 8,2 mA	≤ 8,2 mA	≤ 8,2 mA
Output			
Output switching frequency	10 kHz	6 Hz	15 Hz
Ambient Conditions			
Ambient temperature °F	-4°F ... +158°F (Single device) -4°F ... +140°F (Group assembly)	-4°F ... +158°F (Single device) -4°F ... +140°F (Group assembly)	-4°F ... +158°F (Single device) -4°F ... +140°F (Group assembly)
Ambient temperature °C	-20 °C ... +70 °C (Single device) -20 °C ... +60 °C (Group assembly)	-20 °C ... +70 °C (Single device) -20 °C ... +60 °C (Group assembly)	-20 °C ... +70 °C (Single device) -20 °C ... +60 °C (Group assembly)
Storage temperature °F	-40°F ... +176°F	-40°F ... +176°F	-40°F ... +176°F
Storage temperature °C	-40 °C ... +80 °C	-40 °C ... +80 °C	-40 °C ... +80 °C
Mounting / Installation			
Mounting type	NS35/15, NS35/7.5 DIN rail	NS35/15, NS35/7.5 DIN rail	NS35/15, NS35/7.5 DIN rail
Accessories and spare parts see page 216			

07 b

Technical Drawings – Subject to Alterations

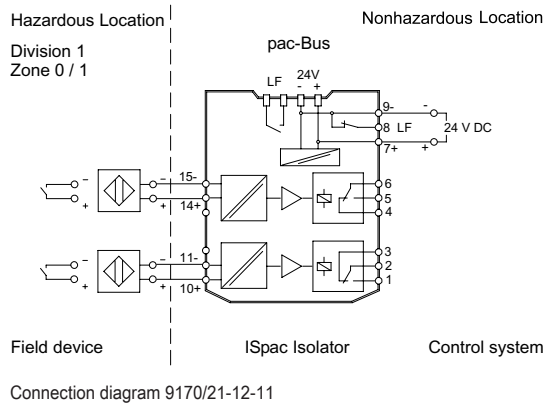
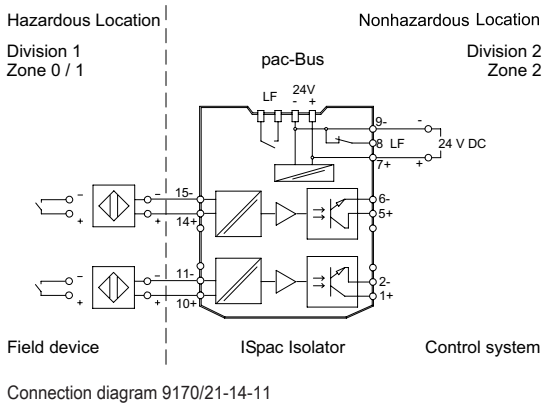

07 b

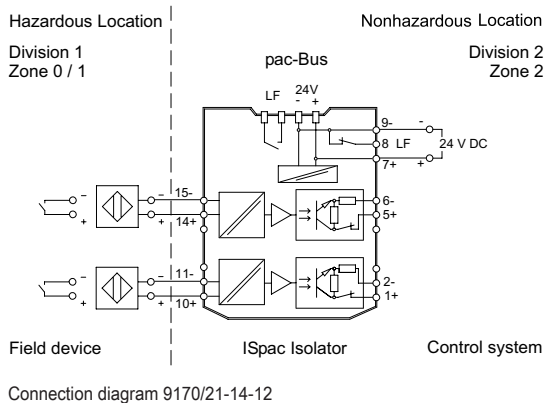
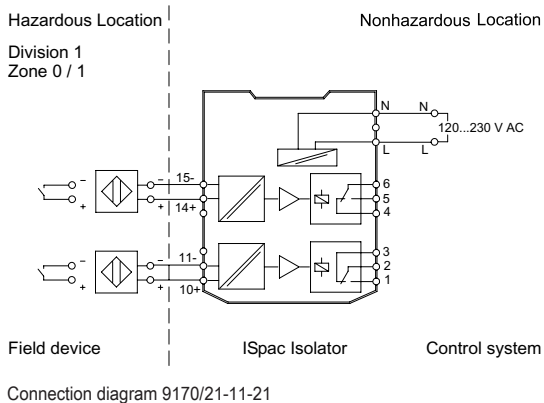
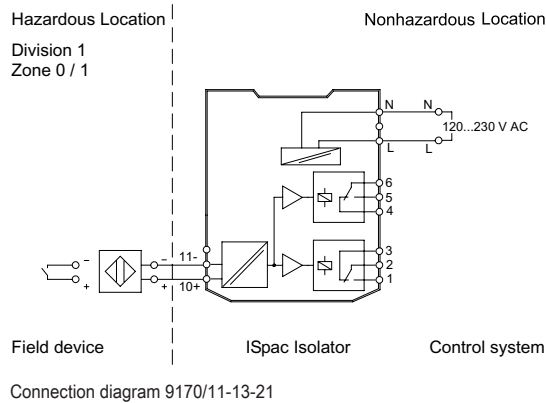
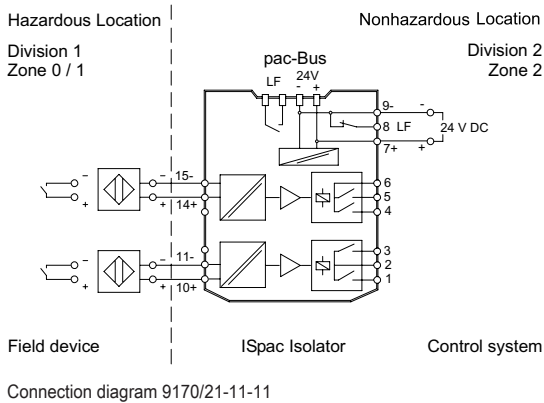
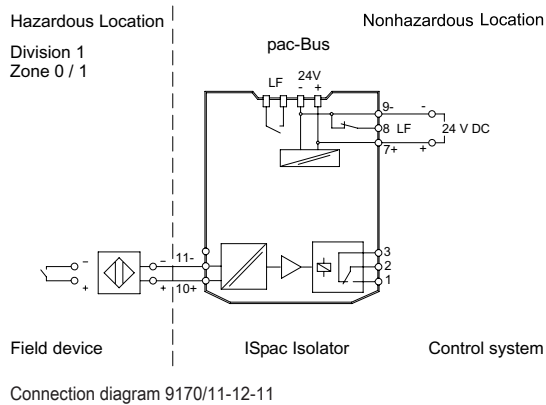
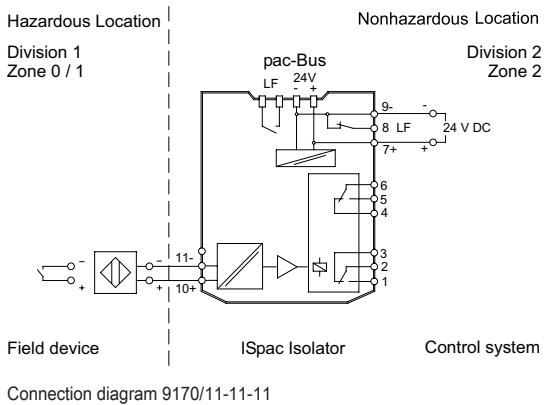

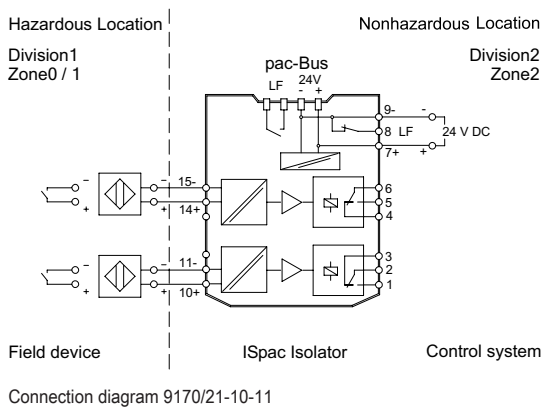

Connection diagram 9170/21-10-11

Dimensional drawings see page 217

07 b



- Slim design – 12.5 mm wide – for one- and two-channel versions
- Can be used for functional safety levels up to SIL 2 (IEC/EN 61508)
- Offers line fault detection with signalization

WebCode **9270A**



07 b

Series 9270 switching repeaters can be used for operating contacts, NAMUR proximity sensors or optocouplers. A relay output or electronic output transmits the signals to the control level. The intrinsically safe digital input is galvanically separated from the output and auxiliary power.

	NEC® 500 CEC Appendix J						CEC Section 18						IECEX / ATEX					
	Class I		Class II		Class III		NEC® 505 Class I			NEC® 506			Zone		Ex interface		Installation in	
Division	1	2	1	2	1	2	0	1	2	20	21	22	0	1	2	20	21	22
Ex interface	•	•	•	•	•	•	•	•	•				•	•	•	•	•	•
Installation in		•						•						•				

Selection Table					
Output version (control)		Electronic (35 V / 50 mA)			
Number of channels	Output per channel	Product Type	Art. No.	Weight lb	
1	2 electronic outputs	9270/11-19-15s	261412 ▲	0.35	
2	1 electronic output	9270/21-14-14s	261413 ▲	0.36	
Output version (control)		Relay (250 V / 2 A)			
Number of channels	Output per channel	Product Type	Art. No.	Weight lb	
1	1 change-over contact	9270/11-16-14s	261409 ▲	0.35	
	2 NOs	9270/11-17-15s	261410	0.36	
2	1 NO	9270/21-17-14s	261411 ▲	0.37	

Technical Data		
Variant	Electronic (35 V / 50 mA)	Relay (250 V / 2 A)
Explosion Protection		
USA certificate UL	E81680	E81680
CAN certificate UL	E81680	E81680
USA marking UL	Class I, Div. 2, Groups A,B,C,D; Class I, Zone 2, Ex nA nC Group IIC; AIS Class I,II,III, Div. 1, Groups A,B,C,D,E,F,G; Class I, Zone 0, [Ex ia] IIC; T4 any mounting position Ta = 60°C; See Doc. 9270 6 031 001 3	Class I, Div. 2, Groups A,B,C,D; Class I, Zone 2, Ex nA nC Group IIC; AIS Class I,II,III, Div. 1, Groups A,B,C,D,E,F,G; Class I, Zone 0, [Ex ia] IIC; T4 any mounting position Ta = 60°C; See Doc. 9270 6 031 001 3

Technical Data		
Variant	Electronic (35 V / 50 mA)	Relay (250 V / 2 A)
Explosion Protection		
CAN marking UL	Class I, Div. 2, Groups A,B,C,D; Class I, Zone 2, Ex nA nC Group IIC; AIS Class I,II,III, Div. 1, Groups A,B,C,D,E,F,G; Class I, Zone 0, [Ex ia] IIC; T4 any mounting position Ta = 60°C; See Doc. 9270 6 031 001 3	Class I, Div. 2, Groups A,B,C,D; Class I, Zone 2, Ex nA nC Group IIC; AIS Class I,II,III, Div. 1, Groups A,B,C,D,E,F,G; Class I, Zone 0, [Ex ia] IIC; T4 any mounting position Ta = 60°C; See Doc. 9270 6 031 001 3
IECEX gas explosion protection	Ex nA Gc, [Ex ia Ga] IIC T4 Gc	Ex nA nC [Ex ia Ga] IIC T4 Gc
IECEX dust explosion protection	[Ex ia Da] IIIC	[Ex ia Da] IIIC
Certificates	ATEX (IBE), Canada / USA (UL), IECEx (IBE), SIL (exida)	ATEX (IBE), Canada / USA (UL), IECEx (IBE), SIL (exida)
Ship approval	DNV GL	DNV GL
Safety Data		
Max. voltage U_0/V_{oc}	9.6 V	9.6 V
Max. current I_0/I_{sc}	10 mA	10 mA
Max. power P_0	25 mW	25 mW
Safety-related maximum voltage	253 V AC	253 V AC
Functional Safety		
SIL	2	2
Input		
Input signal	In accordance with EN 60947-5-6 (NAMUR)	In accordance with EN 60947-5-6 (NAMUR)
Input current for ON	$\geq 2,1$ mA	$\geq 2,1$ mA
Input current for OFF	$\leq 1,2$ mA	$\leq 1,2$ mA
Input for open-circuit voltage U_a	8 V	8 V
Output		
Output switching frequency	5 kHz	20 Hz
Output switching capacity	30 V DC	500 VA
Ambient Conditions		
Ambient temperature °F	-4°F ... +158°F	-4°F ... +158°F
Ambient temperature °C	-20 °C ... +60 °C	-20 °C ... +60 °C
Storage temperature °F	-40°F ... +176°F	-40°F ... +176°F
Storage temperature °C	-40 °C ... +80 °C	-40 °C ... +80 °C
Mounting / Installation		
Mounting type	NS35/15, NS35/7.5 DIN rail	NS35/15, NS35/7.5 DIN rail
Accessories and spare parts see page 216		

07b

Technical Drawings – Subject to Alterations

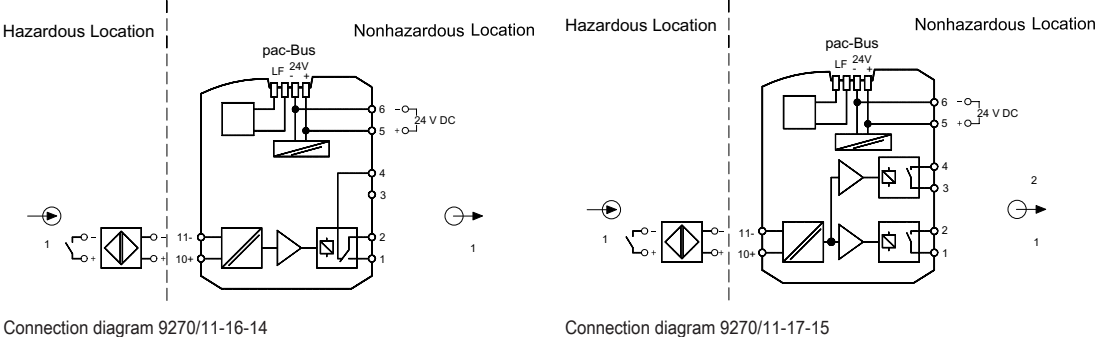

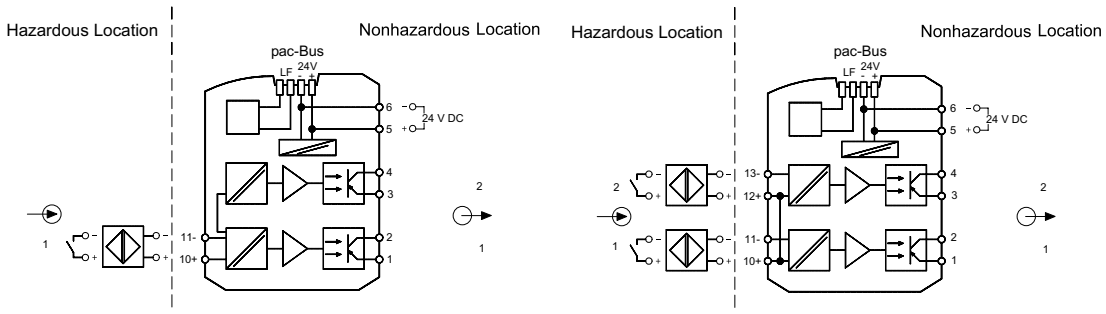

Connection diagram 9270/11-19-15

Connection diagram 9270/21-14-14

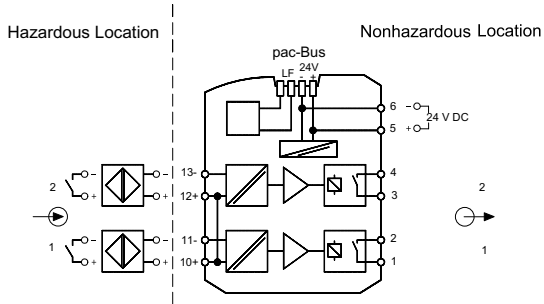

Connection diagram 9270/21-17-14

07 b

Dimensional drawings see page 217



- Binary input or output with two channels
- For separating intrinsically safe and non-intrinsically safe signal and control circuits
- Can be used up to SIL 2 (IEC/EN 61508)

WebCode **9172A**



The 9172 series relay module separates intrinsically safe and non-intrinsically safe binary signal and control circuits. To do this, it makes intrinsically safe inputs and outputs available with two channels. Depending on the version, the device has either an intrinsically safe drive or an intrinsically safe output contact, and can therefore be used as an output or input isolator.

07 b

	NEC® 500 CEC Appendix J					
	Class I		Class II		Class III	
Division	1	2	1	2	1	2
Ex interface	•	•	•	•	•	•
Installation in		•				

	CEC Section 18					
	NEC® 505 Class I			NEC® 506		
Zone	0	1	2	20	21	22
Ex interface	•	•	•			
Installation in			•			

	IECEx / ATEX					
	Zone	0	1	2	20	21
Ex interface	•	•	•	•	•	•
Installation in			•			

Selection Table				
Input signal	Ex i			
Switching signal input	14 – 30 V			
Number of channels	Output	Product Type	Art. No.	Weight lb
2	Change-over contact - Ex i	9172/22-11-00s	169653	0.42
	Change-over contact - power relay	9172/20-11-00s	160363	0.42
Input	Non-Ex i signal			
Switching signal input	12 – 31.2 V			
Number of channels	Output	Product Type	Art. No.	Weight lb
2	Change-over contact - Ex i	9172/21-11-00s	160369	0.42

The order numbers listed in the table are for devices equipped with screw terminals. Further versions on the Internet r-stahl.com.

Technical Data		
Variant	Input signal: Ex i	Input signal: Non-Ex i signal
Explosion Protection		
USA certificate FM	FM16US0122X	FM16US0122X
USA certificate UL	E81680V1S7	E81680V1S7
CAN certificate FM	FM16CA0067X	FM16CA0067X
CAN certificate UL	E81680V1S7	E81680V1S7

07 b

Technical Data		
Variant	Input signal: Ex i	Input signal: Non-Ex i signal
Explosion Protection		
USA marking FM	Class I, Div. 2, Groups A,B,C,D; Class I, Zone 2, Group IIC; AIS Class I,II,III, Div. 1, Groups A,B,C,D,E,F,G; Class I, Zone 0, [AEx ia] IIC; T4 at Ta = 70°C; See Doc. 91 726 01 31 1	Class I, Div. 2, Groups A,B,C,D; Class I, Zone 2, Group IIC; AIS Class I,II,III, Div. 1, Groups A,B,C,D,E,F,G; Class I, Zone 0, [AEx ia] IIC; T4 at Ta = 70°C; See Doc. 91 726 01 31 1
USA marking UL	providing intrinsically safe circuits for use in Class I, Groups A,B,C,D; Class II, Groups E,F,G; Class III; See Doc. 91 726 01 31 3	providing intrinsically safe circuits for use in Class I, Groups A,B,C,D; Class II, Groups E,F,G; Class III; See Doc. 91 726 01 31 3
CAN marking FM	Class I, Div. 2, Groups A,B,C,D; Class I, Zone 2, Group IIC; AIS Class I,II,III, Div. 1, Groups A,B,C,D,E,F,G; Class I, Zone 0, [Ex ia] IIC; T4 at Ta = 70°C; See Doc. 91 726 01 31 1	Class I, Div. 2, Groups A,B,C,D; Class I, Zone 2, Group IIC; AIS Class I,II,III, Div. 1, Groups A,B,C,D,E,F,G; Class I, Zone 0, [Ex ia] IIC; T4 at Ta = 70°C; See Doc. 91 726 01 31 1
CAN marking UL	providing intrinsically safe circuits for use in Class I, Groups A,B,C,D; Class II, Groups E,F,G; Class III; See Doc. 91 726 01 31 3	providing intrinsically safe circuits for use in Class I, Groups A,B,C,D; Class II, Groups E,F,G; Class III; See Doc. 91 726 01 31 3
IECEx gas explosion protection	Ex nA nC [ia Ga] IIC T4 Gc	Ex nA nC [ia Ga] IIC T4 Gc
IECEx dust explosion protection	[Ex ia Da] IIIC	[Ex ia Da] IIIC
Installation	in Zone 2, Division 2 and in the safe area	in Zone 2, Division 2 and in the safe area
Further information	see respective certificate and operating instructions	see respective certificate and operating instructions
Certificates	ATEX (BVS), Canada / USA (UL), Canada (FM), IECEx (BVS), India (PESO), SIL (exida), USA (FM)	ATEX (BVS), Canada / USA (UL), Canada (FM), IECEx (BVS), India (PESO), SIL (exida), USA (FM)
Ship approval	CCS, DNV GL	CCS, DNV GL
Safety Data		
Max. voltage U _i	30 V	
Max. current I _i	150 mA	
Max. power P _i	1.3 W	
Internal capacitance C _i	Negligible	Negligible
Internal inductance L _i	Negligible	Negligible
Safety-related maximum voltage	253 V	253 V
Functional Safety		
SIL	2	2
Auxiliary Power		
Power dissipation max.	0.4 W	0.4 W
Auxiliary power	Without	Without
Ambient Conditions		
Ambient temperature °F	-4°F ... +158°F (Single device) -4°F ... +140°F (Group assembly)	-4°F ... +158°F (Single device) -4°F ... +140°F (Group assembly)
Ambient temperature °C	-20 °C ... +70 °C (Single device) -20 °C ... +60 °C (Group assembly)	-20 °C ... +70 °C (Single device) -20 °C ... +60 °C (Group assembly)
Storage temperature °F	-40°F ... +176°F	-40°F ... +176°F
Storage temperature °C	-40 °C ... +80 °C	-40 °C ... +80 °C
Mounting / Installation		
Mounting type	NS35/15, NS35/7.5 DIN rail	NS35/15, NS35/7.5 DIN rail
Accessories and spare parts see page 216		

Technical Drawings – Subject to Alterations

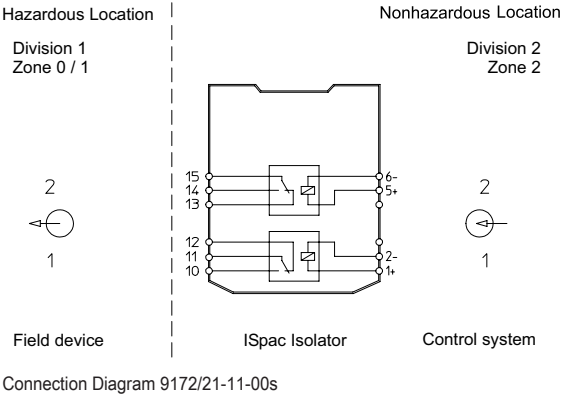
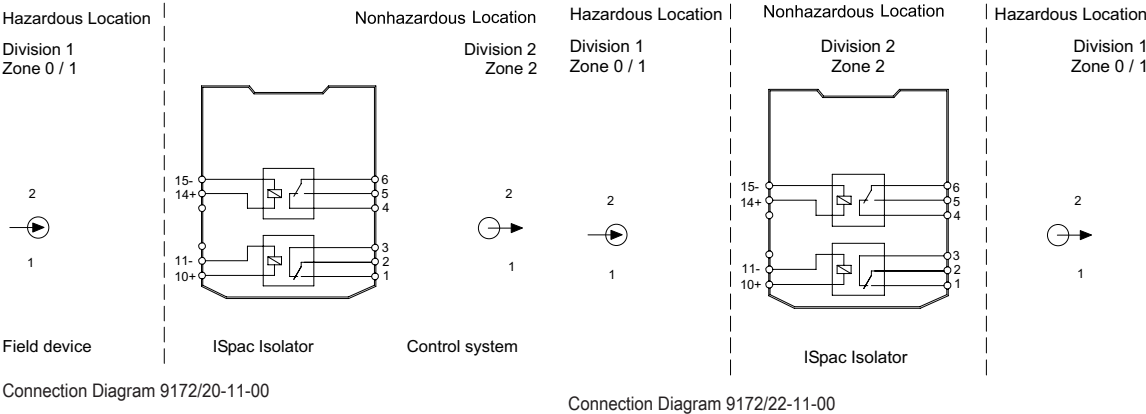

07b

Dimensional drawings see page 217



- Comprehensive portfolio to cater for all characteristics
- Two-channel variants reduce the amount of space required
- Can be used up to SIL 3 (IEC/EN 61508)
- For interface solenoid valves and LEDs

WebCode **9175A**



07 b

9175 series binary outputs issue binary signals via one or two channels for the intrinsically safe operation of Ex i solenoid valves, indicator lamps or horns. The devices feature three-way galvanic separation. A wire-breakage and short-circuit monitoring system, which can be disconnected, directly monitors the state of the field circuit.

	NEC® 500 CEC Appendix J					
	Class I		Class II		Class III	
Division	1	2	1	2	1	2
Ex interface	•	•	•	•	•	•
Installation in		•				

	CEC Section 18					
	NEC® 505 Class I			NEC® 506		
Zone	0	1	2	20	21	22
Ex interface	•	•	•			
Installation in			•			

	IECEX / ATEX					
	Zone	0	1	2	20	21
Ex interface	•	•	•	•	•	•
Installation in			•			

Selection Table						
Number of channels		1				
Output open-circuit voltage U_o	Max. output current $I_{o\ max}$	Internal Resistance R_i	Product Type	Art. No.	Weight lb	
25 V	35 mA	250 Ω	9175/10-16-11s	160416	0.39	
Number of channels		2				
Output open-circuit voltage U_o	Max. output current $I_{o\ max}$	Internal Resistance R_i	Product Type	Art. No.	Weight lb	
10 V	60 mA / Channels parallel: 120 mA*	150 Ω / 75 Ω *	9175/20-12-11s	160404 ▲	0.42	
17.5 V	45 mA / Channels parallel: 90 mA*	130 Ω / 65 Ω *	9175/20-14-11s	160413 ▲	0.42	
25 V	35 mA / Channels parallel: 70 mA*	250 Ω / 125 Ω *	9175/20-16-11s	160419 ▲	0.42	

* Parallel connection of the outputs possible; thus, doubling the output current.

The order numbers listed in the table are for devices equipped with screw terminals. Further versions on the Internet r-stahl.com.

Technical Data			
Variant	Type 9175/20-12-11.	Type 9175/20-14-11.	Type 9175/0-16-11.
Explosion Protection			
USA certificate FM	FM16US0122X	FM16US0122X	FM16US0122X
USA certificate UL	E81680V1S7	E81680V1S7	E81680V1S7
CAN certificate FM	FM16CA0067X	FM16CA0067X	FM16CA0067X
CAN certificate UL	E81680V1S7	E81680V1S7	E81680V1S7

Technical Data			
Variant	Type 9175/20-12-11.	Type 9175/20-14-11.	Type 9175/0-16-11.
Explosion Protection			
USA marking FM	Class I, Div. 2, Groups A,B,C,D; Class I, Zone 2, Group IIC; AIS Class I,II,III, Div. 1, Groups A,B,C,D,E,F,G; Class I, Zone 0, [AEx ia] IIC; T4 Mounting vertical Ta = 70°C or horizontal Ta = 60°C; See Doc. 91 756 01 31 1	Class I, Div. 2, Groups A,B,C,D; Class I, Zone 2, Group IIC; AIS Class I,II,III, Div. 1, Groups A,B,C,D,E,F,G; Class I, Zone 0, [AEx ia] IIC; T4 Mounting vertical Ta = 70°C or horizontal Ta = 60°C; See Doc. 91 756 01 31 1	Class I, Div. 2, Groups A,B,C,D; Class I, Zone 2, Group IIC; AIS Class I,II,III, Div. 1, Groups A,B,C,D,E,F,G; Class I, Zone 0, [AEx ia] IIC; T4 Mounting vertical Ta = 70°C or horizontal Ta = 60°C; See Doc. 91 756 01 31 1
USA marking UL	providing intrinsically safe circuits for use in Class I, Groups A,B,C,D; Class II, Groups E,F,G; Class III; See Doc. 91 756 01 31 3	providing intrinsically safe circuits for use in Class I, Groups A,B,C,D; Class II, Groups E,F,G; Class III; See Doc. 91 756 01 31 3	providing intrinsically safe circuits for use in Class I, Groups A,B,C,D; Class II, Groups E,F,G; Class III; See Doc. 91 756 01 31 3
CAN marking FM	Class I, Div. 2, Groups A,B,C,D; Class I, Zone 2, Group IIC; AIS Class I,II,III, Div. 1, Groups A,B,C,D,E,F,G; Class I, Zone 0, [Ex ia] IIC; T4 Mounting vertical Ta = 70°C or horizontal Ta = 60°C; See Doc. 91 756 01 31 1	Class I, Div. 2, Groups A,B,C,D; Class I, Zone 2, Group IIC; AIS Class I,II,III, Div. 1, Groups A,B,C,D,E,F,G; Class I, Zone 0, [Ex ia] IIC; T4 Mounting vertical Ta = 70°C or horizontal Ta = 60°C; See Doc. 91 756 01 31 1	Class I, Div. 2, Groups A,B,C,D; Class I, Zone 2, Group IIC; AIS Class I,II,III, Div. 1, Groups A,B,C,D,E,F,G; Class I, Zone 0, [Ex ia] IIC; T4 Mounting vertical Ta = 70°C or horizontal Ta = 60°C; See Doc. 91 756 01 31 1
CAN marking UL	providing intrinsically safe circuits for use in Class I, Groups A,B,C,D; Class II, Groups E,F,G; Class III; See Doc. 91 756 01 31 3	providing intrinsically safe circuits for use in Class I, Groups A,B,C,D; Class II, Groups E,F,G; Class III; See Doc. 91 756 01 31 3	providing intrinsically safe circuits for use in Class I, Groups A,B,C,D; Class II, Groups E,F,G; Class III; See Doc. 91 756 01 31 3
IECEX gas explosion protection	Ex nA nC [ia Ga] IIC T4 Gc	Ex nA nC [ia Ga] IIC T4 Gc	Ex nA nC [ia Ga] IIC T4 Gc
IECEX dust explosion protection	[Ex ia Da] IIIC	[Ex ia Da] IIIC	[Ex ia Da] IIIC
Certificates	ATEX (BVS), Brazil (ULB), Canada / USA (UL), Canada (FM), IECEx (BVS), India (PESO), Korea (KTL), SIL (exida), USA (FM)	ATEX (BVS), Brazil (ULB), Canada / USA (UL), Canada (FM), IECEx (BVS), India (PESO), Korea (KTL), SIL (exida), USA (FM)	ATEX (BVS), Brazil (ULB), Canada / USA (UL), Canada (FM), IECEx (BVS), India (PESO), Korea (KTL), SIL (exida), USA (FM)
Ship approval	CCS, DNV GL	CCS, DNV GL	CCS, DNV GL
Safety Data			
Max. voltage U_j/V_{oc}	11.3 V	19.6 V	27.6 V
Max. current I_o (Ex ia)	75 mA	150 mA	110 mA
Max. current I_o (Ex ib)		60 mA	50 mA
Max. power P_o	210 mW	732 mW	760 mW
Safety-related maximum voltage	253 V	253 V	253 V
Functional Safety			
SIL	3	3	3
Auxiliary Power			
Auxiliary power	24 V DC	24 V DC	24 V DC
Nominal current	140 mA	140 mA	140 mA
Input			
Input voltage for ON	15 – 31.2 V	15 – 31.2 V	15 – 31.2 V
Input voltage for OFF	0 – 5 V	0 – 5 V	0 – 5 V
Output			
Output open-circuit voltage U_o	10 V	17.5 V	25 V
Max. output current $I_{o,max}$	60 mA / Channels parallel: 120 mA*	45 mA / Channels parallel: 90 mA*	35 mA / Channels parallel: 70 mA*
Internal Resistance R_i	150 Ω / 75 Ω^*	130 Ω / 65 Ω^*	250 Ω / 125 Ω^*
Output residual ripple	< 50 mV	< 50 mV	< 50 mV
Output switching frequency	\leq 200 Hz	\leq 200 Hz	\leq 200 Hz
Switching delay ON/OFF	\leq 1 ms	\leq 1 ms	\leq 1 ms
Line fault and loss of power signalization	Contact (30 V / 100 mA) closed to ground in case of fault pac-Bus, floating contact (30 V / 100 mA)	Contact (30 V / 100 mA) closed to ground in case of fault pac-Bus, floating contact (30 V / 100 mA)	Contact (30 V / 100 mA) closed to ground in case of fault pac-Bus, floating contact (30 V / 100 mA)
Notes	* Parallel connection of the outputs possible; thus, doubling the output current. Output characteristics, see technical drawings		

Technical Data			
Variant	Type 9175/20-12-11.	Type 9175/20-14-11.	Type 9175/0-16-11.
Ambient Conditions			
Ambient temperature °F	-4°F ... +158°F (Single device) -4°F ... +140°F (Group assembly)	-4°F ... +158°F (Single device) -4°F ... +140°F (Group assembly)	-4°F ... +158°F (Single device) -4°F ... +140°F (Group assembly)
Ambient temperature °C	-20 °C ... +70 °C (Single device) -20 °C ... +60 °C (Group assembly)	-20 °C ... +70 °C (Single device) -20 °C ... +60 °C (Group assembly)	-20 °C ... +70 °C (Single device) -20 °C ... +60 °C (Group assembly)
Storage temperature °F	-40°F ... +176°F	-40°F ... +176°F	-40°F ... +176°F
Storage temperature °C	-40 °C ... +80 °C	-40 °C ... +80 °C	-40 °C ... +80 °C
Mounting / Installation			
Mounting type	NS35/15, NS35/7.5 DIN rail	NS35/15, NS35/7.5 DIN rail	NS35/15, NS35/7.5 DIN rail
Accessories and spare parts see page 216			

Technical Drawings – Subject to Alterations

07 b

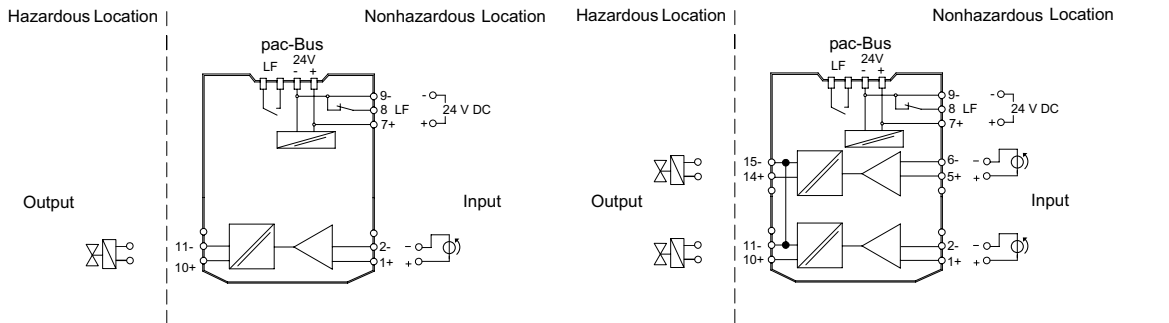

Connection Diagram 9175/10-16-11

Connection Diagram 9175/20-1x-11

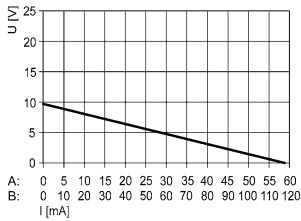

Output characteristic 9175/0-12-11, 9176/0-12-00

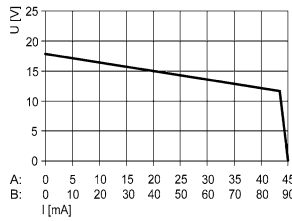

Output characteristic 9175/0-14-11, 9176/0-14-00

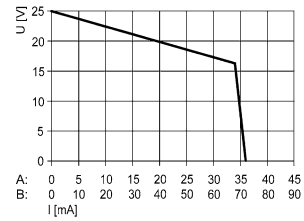

Output characteristic 9175/0-16-11; 9176/0-16-00

Dimensional drawings see page 217



- Space savings due to a slim design – 12.5 mm wide
- Can be used for functional safety levels up to SIL 3 (IEC/EN 61508)
- Offers line fault detection with signalization
- For interface with solenoid valves and LEDs

WebCode **9275A**



Series 9275 digital outputs issue signals for the intrinsically safe operation of Ex i solenoid valves, indicator lamps or horns. The devices feature three-way galvanic separation.

07 b

	NEC® 500 CEC Appendix J					
	Class I		Class II		Class III	
Division	1	2	1	2	1	2
Ex interface	•	•	•	•	•	•
Installation in		•				

	CEC Section 18 NEC® 505 NEC® 506					
	Class I			Class II		
Zone	0	1	2	20	21	22
Ex interface	•	•	•			
Installation in			•			

	IECEX / ATEX					
	Zone 0		Zone 1		Zone 2	
Zone	0	1	2	20	21	22
Ex interface	•	•	•	•	•	•
Installation in		•				

Selection Table						
Number of channels	1					
Output open-circuit voltage U_o	Max. output current $I_{o,max}$	Output internal resistance R_i	LFD relay	Product Type	Art. No.	Weight lb
21.1 V	25.1 mA	641 Ω	Yes	9275/10-21-25-11s	261434	0.35
24.3 V	48 mA	297 Ω	Yes	9275/10-24-48-11s	261435 ▲	0.35

Technical Data		
Variant	9275/10-21-25-11s	9275/10-24-48-11s
Explosion Protection		
USA certificate UL	E81680	E81680
CAN certificate UL	E81680	E81680
USA marking UL	Class I, Div. 2, Groups A,B,C,D; Class I, Zone 2, Ex nA Group IIC; AIS Class I,II,III, Div. 1, Groups A,B,C,D,E,F,G; Class I, Zone 0, [Ex ia] IIC; T4 any mounting position Ta = 60°C; See Doc. 9275 6 031 001 3	Class I, Div. 2, Groups A,B,C,D; Class I, Zone 2, Ex nA Group IIC; AIS Class I,II,III, Div. 1, Groups A,B,C,D,E,F,G; Class I, Zone 0, [Ex ia] IIC; T4 any mounting position Ta = 60°C; See Doc. 9275 6 031 001 3
CAN marking UL	Class I, Div. 2, Groups A,B,C,D; Class I, Zone 2, Ex nA Group IIC; AIS Class I,II,III, Div. 1, Groups A,B,C,D,E,F,G; Class I, Zone 0, [Ex ia] IIC; T4 any mounting position Ta = 60°C; See Doc. 9275 6 031 001 3	Class I, Div. 2, Groups A,B,C,D; Class I, Zone 2, Ex nA Group IIC; AIS Class I,II,III, Div. 1, Groups A,B,C,D,E,F,G; Class I, Zone 0, [Ex ia] IIC; T4 any mounting position Ta = 60°C; See Doc. 9275 6 031 001 3
IECEX gas explosion protection	Ex nA [ja Ga] IIC T4 Gc	Ex nA [ja Ga] IIC T4 Gc
IECEX dust explosion protection	[Ex ia Da] IIIC	[Ex ia Da] IIIC
Certificates	ATEX (IBE), Canada / USA (UL), IECEX (IBE), SIL (BVS)	ATEX (IBE), Canada / USA (UL), IECEX (IBE), SIL (BVS)
Ship approval	DNV GL	DNV GL
Safety Data		
Max. voltage U_o/V_{oc}	23.98 V	27.06 V

07 b

Technical Data		
Variant	9275/10-21-25-11s	9275/10-24-48-11s
Safety Data		
Max. current I_o (Ex ia)	37.4 mA	91.11 mA
Max. power P_o	224 mW	616 mW
Safety-related maximum voltage	253 V AC	253 V AC
Functional Safety		
SIL	3	3
Auxiliary Power		
Auxiliary power	24 V DC	24 V DC
Nominal current	50 mA	90 mA
Power consumption	1.2 W	2.16 W
Polarity reversal protection	Yes	Yes
Input		
Input voltage for ON	15 – 30 V	15 – 30 V
Input voltage for OFF	0 – 5 V	0 – 5 V
Output		
Output open-circuit voltage U_o	21.1 V	24.3 V
Max. output current $I_{o,max}$	25.1 mA	48 mA
Output internal resistance R_i	641 Ω	297 Ω
Switching delay ON/OFF	< 30 ms	< 30 ms
Switching capacity fault message contact	30 V / 50 mA	30 V / 50 mA
Notes	Output characteristics, see technical drawings	
Ambient Conditions		
Ambient temperature °F	-4°F ... +140°F	-4°F ... +140°F
Ambient temperature °C	-20 °C ... +60 °C	-20 °C ... +60 °C
Storage temperature °F	-40°F ... +176°F	-40°F ... +176°F
Storage temperature °C	-40 °C ... +80 °C	-40 °C ... +80 °C
Mounting / Installation		
Mounting type	NS35/15, NS35/7.5 DIN rail	NS35/15, NS35/7.5 DIN rail
Accessories and spare parts see page 216 Dimensional drawings see page 217		

Technical Drawings – Subject to Alterations

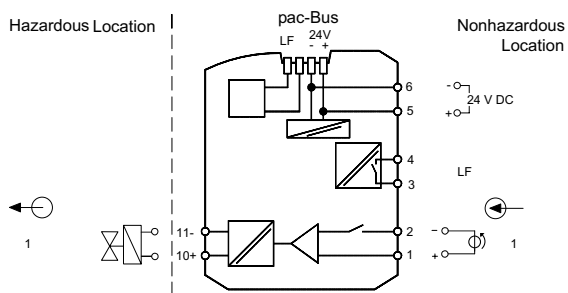

Connection diagram 9275/10

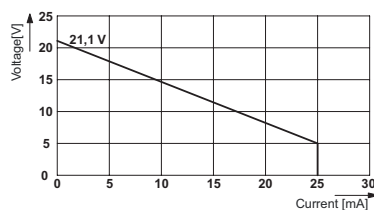

Output characteristic curve 9275/10-21-25-11

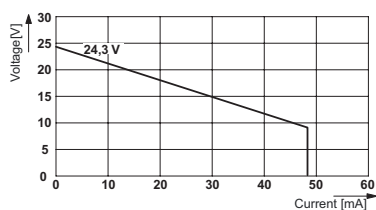

Output characteristic curve 9275/10-24-48-11



- Comprehensive portfolio to cater for all characteristics
- Two-channel variants reduce the amount of space required
- Can be used up to SIL 3 (IEC/EN 61508)

WebCode **9176A**



9176 series binary outputs issue binary signals for the intrinsically safe operation of Ex i solenoid valves, indicator lamps or horns. The devices do not require a separate auxiliary power supply as they are powered by the control circuit. The intrinsically safe outputs are galvanically separated from the inputs. The two-channel variants are characterised by galvanically separated channels.

07 b

	NEC® 500 CEC Appendix J					
	Class I		Class II		Class III	
Division	1	2	1	2	1	2
Ex interface	•	•	•	•	•	•
Installation in		•				

	CEC Section 18					
	NEC® 505 Class I			NEC® 506		
Zone	0	1	2	20	21	22
Ex interface	•	•	•			
Installation in			•			

	IECEX / ATEX					
	Zone	0	1	2	20	21
Ex interface	•	•	•	•	•	•
Installation in			•			

Selection Table						
Number of channels		1				
Output open-circuit voltage U_o	Max. output current $I_{o, max}$	Internal Resistance R_i	Product Type	Art. No.	Weight lb	
25 V	35 mA	250 Ω	9176/10-16-00s	222182	0.37	
Number of channels		2				
Output open-circuit voltage U_o	Max. output current $I_{o, max}$	Internal Resistance R_i	Product Type	Art. No.	Weight lb	
25 V	29 mA / 58 mA*	320 Ω / 160 Ω *	9176/20-15-00s	222180	0.41	
	35 mA / 70 mA*	250 Ω / 125 Ω *	9176/20-16-00s	222184 ▲	0.41	
	43 mA / 86 mA*	460 Ω / 230 Ω *	9176/20-17-00s	222188	0.41	

The order numbers listed in the table are for devices equipped with screw terminals.
Further versions available at r-stahl.com

* Parallel connection of the outputs possible; thus, doubling the output current and halves the internal resistance.

Technical Data			
Variant	9176/20-15-00s	9176/0-16-00s	9176/20-17-00s
Explosion Protection			
USA certificate FM	FM16US0122X	FM16US0122X	FM16US0122X
CAN certificate FM	FM16CA0067X	FM16CA0067X	FM16CA0067X

07 b

Technical Data			
Variant	9176/20-15-00s	9176/0-16-00s	9176/20-17-00s
Explosion Protection			
USA marking FM	Class I, Div. 2, Groups A,B,C,D; Class I, Zone 2, Group IIC; AIS Class I,II,III, Div. 1, Groups A,B,C,D,E,F,G; Class I, Zone 0, [AEx ia] IIC; T4 Mounting vertical Ta = 70°C or horizontal Ta = 60°C; See Doc. 91 766 01 31 1	Class I, Div. 2, Groups A,B,C,D; Class I, Zone 2, Group IIC; AIS Class I,II,III, Div. 1, Groups A,B,C,D,E,F,G; Class I, Zone 0, [AEx ia] IIC; T4 Mounting vertical Ta = 70°C or horizontal Ta = 60°C; See Doc. 91 766 01 31 1	Class I, Div. 2, Groups A,B,C,D; Class I, Zone 2, Group IIC; AIS Class I,II,III, Div. 1, Groups A,B,C,D,E,F,G; Class I, Zone 0, [AEx ia] IIC; T4 Mounting vertical Ta = 70°C or horizontal Ta = 60°C; See Doc. 91 766 01 31 1
CAN marking FM	Class I, Div. 2, Groups A,B,C,D; Class I, Zone 2, Group IIC; AIS Class I,II,III, Div. 1, Groups A,B,C,D,E,F,G; Class I, Zone 0, [Ex ia] IIC; T4 Mounting vertical Ta = 70°C or horizontal Ta = 60°C; See Doc. 91 766 01 31 1	Class I, Div. 2, Groups A,B,C,D; Class I, Zone 2, Group IIC; AIS Class I,II,III, Div. 1, Groups A,B,C,D,E,F,G; Class I, Zone 0, [Ex ia] IIC; T4 Mounting vertical Ta = 70°C or horizontal Ta = 60°C; See Doc. 91 766 01 31 1	Class I, Div. 2, Groups A,B,C,D; Class I, Zone 2, Group IIC; AIS Class I,II,III, Div. 1, Groups A,B,C,D,E,F,G; Class I, Zone 0, [Ex ia] IIC; T4 Mounting vertical Ta = 70°C or horizontal Ta = 60°C; See Doc. 91 766 01 31 1
IECEx gas explosion protection	Ex nA [ja Ga] IIC T4 Gc	Ex nA [ja Ga] IIC T4 Gc	Ex nA [ja Ga] IIC T4 Gc
IECEx dust explosion protection	[Ex ia Da] IIIC	[Ex ia Da] IIIC	[Ex ia Da] IIIC
Certificates	ATEX (BVS), Brazil (ULB), Canada (FM), IECEx (BVS), India (PESO), Korea (KTL), SIL (exida), USA (FM)	ATEX (BVS), Brazil (ULB), Canada (FM), IECEx (BVS), India (PESO), Korea (KTL), SIL (exida), USA (FM)	ATEX (BVS), Brazil (ULB), Canada (FM), IECEx (BVS), India (PESO), Korea (KTL), SIL (exida), USA (FM)
Ship approval	CCS, DNV GL	CCS, DNV GL	CCS, DNV GL
Safety Data			
Max. voltage U/V_{∞}	27.6 V	27.6 V	27.6 V
Max. current I_0 (Ex ia)	86.5 mA	110 mA	60 mA
Max. current I_0 (Ex ib)	44 mA	50 mA	
Max. power P_0	596 mW	760 mW	415 mW
Safety-related maximum voltage	253 V	253 V	253 V
Functional Safety			
SIL	3	3	3
Auxiliary Power			
Auxiliary power	Without	Without	Without
Input			
Input voltage for ON	18 – 31.2 V	18 – 31.2 V	18 – 31.2 V
Input voltage for OFF	0 – 5 V	0 – 5 V	0 – 5 V
Output			
Output open-circuit voltage U_0	25 V	25 V	25 V
Max. output current $I_{0,max}$	29 mA / 58 mA*	35 mA / 70 mA*	43 mA / 86 mA*
Internal Resistance R_i	320 Ω / 160 Ω *	250 Ω / 125 Ω *	460 Ω / 230 Ω *
Output residual ripple	< 100 mV	< 100 mV	< 100 mV
Output switching frequency	\leq 10 Hz	\leq 10 Hz	\leq 10 Hz
Switching delay ON/OFF	\leq 50 ms	\leq 50 ms	\leq 50 ms
Notes	* Parallel connection of the outputs possible; thus, doubling the output current and halves the internal resistance.		
Ambient Conditions			
Ambient temperature °F	-4°F ... +158°F (Single device) -4°F ... +140°F (Group assembly)	-4°F ... +158°F (Single device) -4°F ... +140°F (Group assembly)	-4°F ... +158°F (Single device) -4°F ... +140°F (Group assembly)
Ambient temperature °C	-20 °C ... +70 °C (Single device) -20 °C ... +60 °C (Group assembly)	-20 °C ... +70 °C (Single device) -20 °C ... +60 °C (Group assembly)	-20 °C ... +70 °C (Single device) -20 °C ... +60 °C (Group assembly)
Storage temperature °F	-40°F ... +176°F	-40°F ... +176°F	-40°F ... +176°F
Storage temperature °C	-40 °C ... +80 °C	-40 °C ... +80 °C	-40 °C ... +80 °C
Mounting / Installation			
Mounting type	NS35/15, NS35/7.5 DIN rail	NS35/15, NS35/7.5 DIN rail	NS35/15, NS35/7.5 DIN rail
Accessories and spare parts see page 216			

Technical Drawings – Subject to Alterations

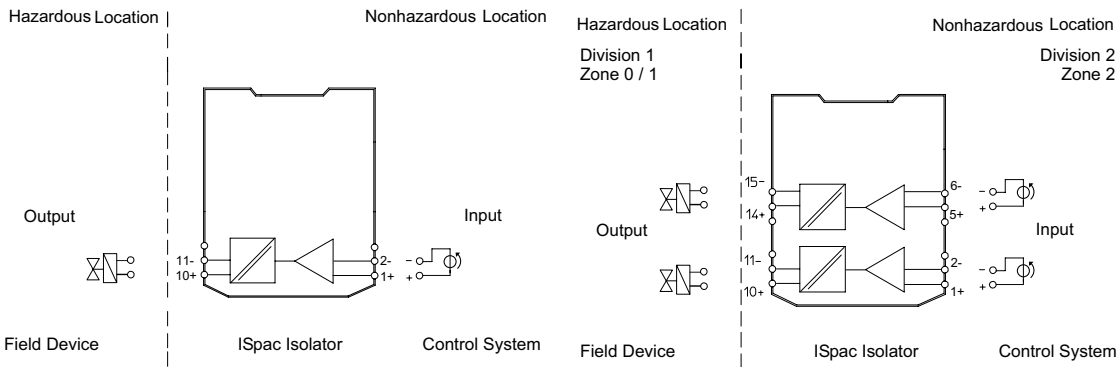

Connection Diagram 9176/10-16-00s

Connection diagram 9176/20

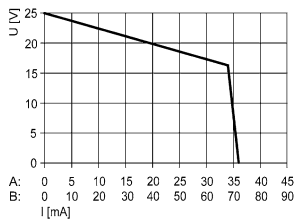

Output characteristic 9175/0-16-11; 9176/0-16-00

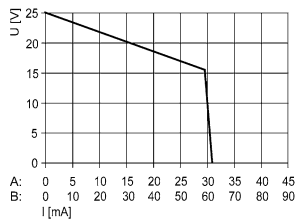

Output characteristic 9176/0-15-00

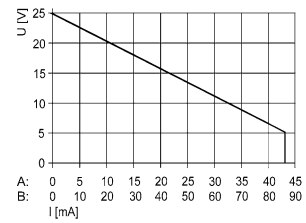

Output characteristic 9176/0-17-00

07b

Dimensional drawings see page 217



- A comprehensive portfolio for a wide range of solenoid valves
- Space savings due to a slim design – 12.5 mm wide
- Can be used for functional safety levels up to SIL 3 (IEC/EN 61508)

WebCode **9276A**



07 b

Series 9276 digital outputs issue signals for the intrinsically safe operation of Ex i solenoid valves, indicator lamps or horns. The devices do not require a separate auxiliary power supply as they are powered by the control circuit. The intrinsically safe outputs are galvanically separated from the inputs.

	NEC® 500 CEC Appendix J						CEC Section 18						IECEX / ATEX					
	Class I		Class II		Class III		NEC® 505 Class I			NEC® 506			Zone		Ex interface		Installation in	
Division	1	2	1	2	1	2	0	1	2	20	21	22	0	1	2	20	21	22
Ex interface	•	•	•	•	•	•	•	•	•				•	•	•	•	•	•
Installation in		•						•						•				

Selection Table								
Number of channels 1								
Max. voltage $U_{V_{oc}}$	Max. current $I_{a (Ex ia)}$	Max. power P_o	Output open-circuit voltage U_o	Output internal resistance R_i	Max. output current $I_{a max}$	Product Type	Art. No.	Weight lb
25.1 V	39 mA	245 mW	21.9 V	641.1 Ω	25 mA	9276/10-21-25-00s	261440	0.36
	87 mA	550 mW	21.9 V	287 Ω	40 mA	9276/10-21-40-00s	261441	0.36
	188 mA	1180 mW	21.9 V	133.4 Ω	58 mA	9276/10-21-60-00s	261443	0.36
27.7 V	101 mA	697 mW	24 V	275.5 Ω	48 mA	9276/10-24-48-00s	261442 ▲	0.36

Technical Data		
Variant	9276/10-21-25-00s, 9276/10-21-40-00s, 9276/10-24-48-00s	9276/10-21-60-00s
Explosion Protection		
USA certificate UL	E81680	E81680
CAN certificate UL	E81680	E81680
USA marking UL	Class I, Div. 2, Groups A,B,C,D; Class I, Zone 2, Ex nA Group IIC; AIS Class I,II,III, Div. 1, Groups A,B,C,D,E,F,G; Class I, Zone 0, [Ex ia] IIC T4 any mounting position Ta = 60°C; See Doc. 9276 6 031 001 3	Class I, Div. 2, Groups A,B,C,D; Class I, Zone 2, Ex nA Group IIC; AIS Class I,II,III, Div. 1, Groups A,B,C,D,E,F,G; Class I, Zone 0, [Ex ia] IIC T4 any mounting position Ta = 60°C; See Doc. 9276 6 031 001 3
CAN marking UL	Class I, Div. 2, Groups A,B,C,D; Class I, Zone 2, Ex nA Group IIC; AIS Class I,II,III, Div. 1, Groups A,B,C,D,E,F,G; Class I, Zone 0, [Ex ia] IIC T4 any mounting position Ta = 60°C; See Doc. 9276 6 031 001 3	Class I, Div. 2, Groups A,B,C,D; Class I, Zone 2, Ex nA Group IIC; AIS Class I,II,III, Div. 1, Groups A,B,C,D,E,F,G; Class I, Zone 0, [Ex ia] IIC T4 any mounting position Ta = 60°C; See Doc. 9276 6 031 001 3
IECEX gas explosion protection	Ex nA [ja Ga] IIC T4 Gc	Ex nA [ja IIB Ga] IIC T4 Gc
IECEX dust explosion protection	[Ex ia Da] IIC	[Ex ia Da] IIC

Technical Data		
Variant	9276/10-21-25-00s, 9276/10-21-40-00s, 9276/10-24-48-00s	9276/10-21-60-00s
Explosion Protection		
Certificates	ATEX (IBE), Canada / USA (UL), IECEx (IBE), SIL (exida)	ATEX (IBE), Canada / USA (UL), IECEx (IBE), SIL (exida)
Ship approval	DNV GL	DNV GL
Safety Data		
Safety-related maximum voltage	253 V AC	253 V AC
Functional Safety		
SIL	3	3
Auxiliary Power		
Auxiliary power	Without	Without
Input		
Input voltage for ON	15 – 30 V	15 – 30 V
Input voltage for OFF	0 – 5 V	0 – 5 V
Output		
Switching delay ON/OFF	≤ 20 ms	≤ 20 ms
Ambient Conditions		
Ambient temperature °F	-4°F ... +140°F	-4°F ... +140°F
Ambient temperature °C	-40 °C ... +60 °C	-40 °C ... +60 °C
Storage temperature °F	-40°F ... +176°F	-40°F ... +176°F
Storage temperature °C	-40 °C ... +80 °C	-40 °C ... +80 °C
Mounting / Installation		
Mounting type	NS35/15, NS35/7.5 DIN rail	NS35/15, NS35/7.5 DIN rail

Accessories and spare parts see page 216; Dimensional drawings see page 217

07b

Technical Drawings – Subject to Alterations

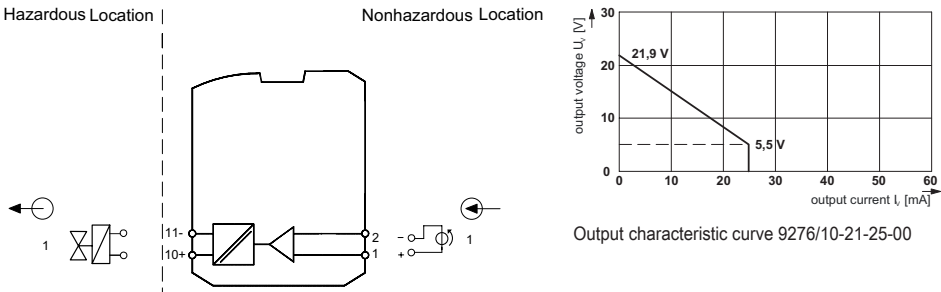

Output characteristic curve 9276/10-21-25-00

Connection diagram 9276/10

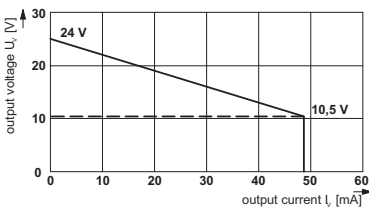

Output characteristic curve 9276/10-24-48-00

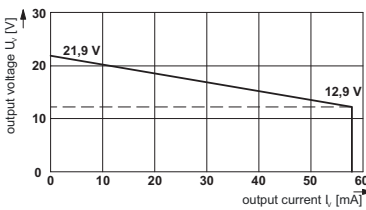

Output characteristic curve 9276/10-21-60-00

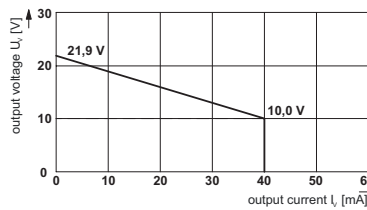

Output characteristic curve 9276/10-21-40-00



- Ex i resistance isolator for Pt100 or Pt1000
- World's only two-channel device requiring just 8.8 mm of space per channel
- For two-, three- and four-conductor connection

WebCode **9180A**



07 b

9180 series Ex i resistance isolators can be used for the intrinsically safe operation of Pt100 or Pt1000 resistance temperature detectors. The resistance measured at the input is transmitted to the output and can thereby be measured by an I/O card. The auxiliary power, output and intrinsically safe input are galvanically separated.

	NEC® 500 CEC Appendix J						CEC Section 18						IECEX / ATEX					
	Class I		Class II		Class III		NEC® 505 Class I			NEC® 506			Zone 0		Zone 1		Zone 2	
Division	1	2	1	2	1	2	0	1	2	20	21	22	0	1	2	20	21	22
Ex interface	•	•	•	•	•	•	•	•	•				•	•	•	•	•	•
Installation in		•							•						•			

Selection Table					
Number of channels	1				
Measuring range	Medium resolution input	Input for resistance temperature detector	Product Type	Art. No.	Weight lb
18 ... 391 Ω	0.01 Ω	Pt 100	9180/10-77-11s	160491 ▲	0.35
180 ... 3910 Ω	0.1 Ω	Pt 1000	9180/11-77-11s	160499	0.35
Number of channels	2				
Measuring range	Medium resolution input	Input for resistance temperature detector	Product Type	Art. No.	Weight lb
18 ... 391 Ω	0.01 Ω	Pt 100	9180/20-77-11s	160494 ▲	0.4
180 ... 3910 Ω	0.1 Ω	Pt 1000	9180/21-77-11s	160502	0.4

The order numbers listed in the table are for devices equipped with screw terminals. Further versions on the Internet r-stahl.com.

Technical Data	
Explosion Protection	
USA certificate FM	FM16US0122X
CAN certificate FM	FM16CA0067X
USA marking FM	Class I, Div. 2, Groups A,B,C,D; Class I, Zone 2, AEx nA nC Group IIC; AIS Class I,II,III, Div. 1, Groups A,B,C,D,E,F,G; Class I, Zone 0, [AEx ia] IIC; T4 at Ta = 70°C; See Doc. 9180 6 031 001 1

Technical Data	
Explosion Protection	
CAN marking FM	Class I, Div. 2, Groups A,B,C,D; Class I, Zone 2, Ex nA nC Group IIC; ALS Class I,II,III, Div. 1, Groups A,B,C,D,E,F,G; Class I, Zone 0, [Ex ia] IIC; T4 at Ta = 70°C; See Doc. 9180 6 031 001 1
IECEX gas explosion protection	Ex nA nC [ia Ga] IIC T4 Gc
IECEX dust explosion protection	[Ex ia Da] IIIC
Certificates	ATEX (BVS), Brazil (ULB), Canada (FM), IECEx (BVS), India (PESO), Korea (KTL), Russia (Meteorological certificate), USA (FM)
Ship approval	CCS, DNV GL
Safety Data	
Max. voltage U_0/V_{oc}	6.5 V
Max. current I_0/I_{sc}	16.4 mA
Max. power P_0	27 mW
Safety-related maximum voltage	253 V
Auxiliary Power	
Auxiliary power	24 V DC
Input	
RTD input	2-,3-,4-wire circuits
Line fault and loss of power signalization	Contact (30 V / 100 mA) closed to ground in case of fault pac-Bus, floating contact (30 V / 100 mA)
Output	
Output signal	Equal to input signal (resistor)
Settling time output	< 10 ms
Response time output	< 1 s
Ambient Conditions	
Ambient temperature °F	-4°F ... +158°F (Single device) -4°F ... +140°F (Group assembly)
Ambient temperature °C	-20 °C ... +70 °C (Single device) -20 °C ... +60 °C (Group assembly)
Storage temperature °F	-40°F ... +176°F
Storage temperature °C	-40 °C ... +80 °C
Mounting / Installation	
Mounting type	NS35/15, NS35/7.5 DIN rail
Accessories and spare parts see page 216	

07b

Technical Drawings – Subject to Alterations

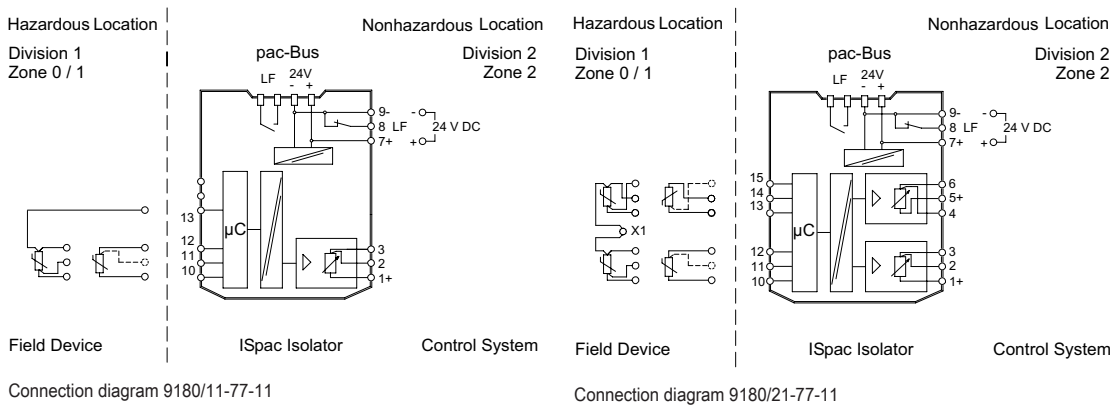

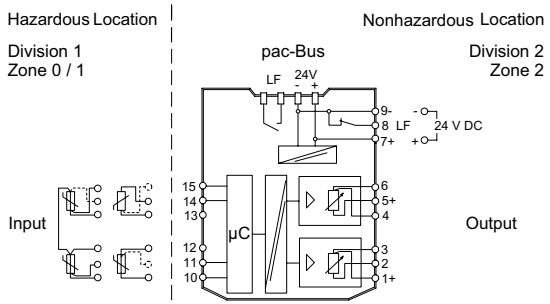

Connection Diagram 9180/20-77-11

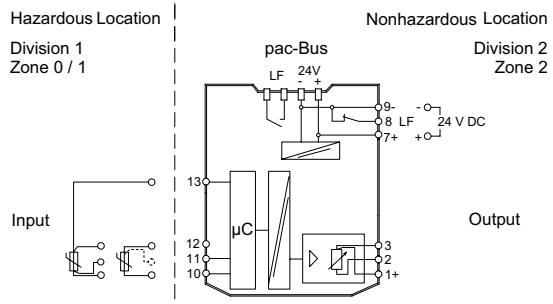

Connection Diagram 9180/10-77-11

Dimensional drawings see page 217



- Ex i temperature transmitter, can be configured for virtually any common sensor type
- Broad range, including variants with signal conversion and trip amplifier function
- Can be used up to SIL 2 (IEC/EN 61508)

WebCode **9182A**



9182 series Ex i temperature transmitters for field circuits can be used to connect temperature sensors and potentiometers. They are easy to configure for virtually any sensor type by means of software or a DIP switch. These sensor types include Pt100 sensors, thermocouples and potentiometers. Variants with a trip amplifier function allow the input signal to be analysed using two independent contacts.

07b

	NEC® 500 CEC Appendix J					
	Class I		Class II		Class III	
Division	1	2	1	2	1	2
Ex interface	•	•	•	•	•	•
Installation in		•				

	CEC Section 18 NEC® 505 NEC® 506					
	Class I					
Zone	0	1	2	20	21	22
Ex interface	•	•	•			
Installation in			•			

	IECEX / ATEX					
	Zone	0	1	2	20	21
Ex interface	•	•	•	•	•	•
Installation in			•			

Selection Table						
Output		0/4 ... 20 mA active / source				
Number of channels	Limit contact (per channel)	Load resistance R _L max.	SIL	Product Type	Art. No.	Weight lb
1	2 NO / NC	750 Ω	2	9182/10-51-14s	201682	0.37
	Without	750 Ω	–	9182/10-51-11s	160546 ▲	0.43
	Without	750 Ω	2	9182/10-51-13s	201653	0.37
2	Without	600 Ω	–	9182/20-51-11s	160541 ▲	0.43
Output		Without				
Number of channels	Limit contact (per channel)	Load resistance R _L max.	SIL	Product Type	Art. No.	Weight lb
2	2 NO / NC	–	–	9182/20-50-12s	160552	0.43

Signal duplication due to parallel connection of inputs (dual-channel version 9182/2). Further information see operating instruction.

The order numbers listed in the table are for devices equipped with screw terminals. Further versions on the Internet r-stahl.com.

Technical Data		
Variant	9182/0-51-1.	9182/20-50-12
Explosion Protection		
USA certificate FM	FM16US0122X	FM16US0122X
CAN certificate FM	FM16CA0067X	FM16CA0067X

Technical Data

Variant	9182/0-51-1	9182/20-50-12
Explosion Protection		
USA marking FM	Class I, Div. 2, Groups A,B,C,D; Class I, Zone 2, Group IIC; AIS Class I,II,III, Div. 1, Groups A,B,C,D,E,F,G; Class I, Zone 0, [AEx ia] IIC; T4 at Ta = 70°C; See Doc. 91 826 01 31 1	Class I, Div. 2, Groups A,B,C,D; Class I, Zone 2, Group IIC; AIS Class I,II,III, Div. 1, Groups A,B,C,D,E,F,G; Class I, Zone 0, [AEx ia] IIC; T4 at Ta = 70°C; See Doc. 91 826 01 31 1
CAN marking FM	Class I, Div. 2, Groups A,B,C,D; Class I, Zone 2, Group IIC; AIS Class I,II,III, Div. 1, Groups A,B,C,D,E,F,G; Class I, Zone 0, [Ex ia] IIC; T4 at Ta = 70°C; See Doc. 91 826 01 31 1	Class I, Div. 2, Groups A,B,C,D; Class I, Zone 2, Group IIC; AIS Class I,II,III, Div. 1, Groups A,B,C,D,E,F,G; Class I, Zone 0, [Ex ia] IIC; T4 at Ta = 70°C; See Doc. 91 826 01 31 1
IECEX gas explosion protection	Ex nA nC [ia Ga] IIC T4 Gc	Ex nAc nCc [ia] IIC T4 Gc
IECEX dust explosion protection	[Ex ia Da] IIIC	[Ex ia] IIIC
Certificates	ATEX (BVS), Brazil (ULB), Canada / USA (UL), Canada (FM), IECEX (BVS), India (PESO), Korea (KTL), Russia (Meteorological certificate), SIL (exida), USA (FM)	ATEX (BVS), Brazil (ULB), Canada / USA (UL), Canada (FM), IECEX (BVS), India (PESO), Korea (KTL), Russia (Meteorological certificate), SIL (exida), USA (FM)
Ship approval	CCS, DNV GL	CCS, DNV GL
Safety Data		
Max. voltage U_j/V_{oc}	6.5 V	6.5 V
Max. current I_j/I_{sc}	19.7 mA	19.7 mA
Max. power P_o	32 mW	32 mW
Safety-related maximum voltage	253 V	253 V
Auxiliary Power		
Auxiliary power	24 V DC	24 V DC
Input		
Input potentiometer	up to 100 kΩ	
Input resistance temperature detector (RTD)	Types Pt 100, Pt 500, Pt 1000, Ni 100, Ni 500, Ni 1000	
Input resistance temperature detector (RTD) Connection type	2-, 3-, 4-wire circuit	
Input thermocouple	Types B, E, J, K, N, R, S, T, L, U, XK	
Line fault and loss of power signalization	Contact (30 V / 100 mA) closed to ground in case of fault pac-Bus, floating contact (30 V / 100 mA)	
Output		
Output	0/4 ... 20 mA active / source	Without
Switching voltage limiting values		≤ ± 30 V
Switching current limiting values		≤ 100 mA
Ambient Conditions		
Ambient temperature °F	-4°F ... +158°F (Single device) -4°F ... +140°F (Group assembly)	-4°F ... +158°F (Single device) -4°F ... +140°F (Group assembly)
Ambient temperature °C	-20 °C ... +70 °C (Single device) -20 °C ... +60 °C (Group assembly)	-20 °C ... +70 °C (Single device) -20 °C ... +60 °C (Group assembly)
Storage temperature °F	-40°F ... +176°F	-40°F ... +176°F
Storage temperature °C	-40 °C ... +80 °C	-40 °C ... +80 °C
Mounting / Installation		
Mounting type	NS35/15, NS35/7.5 DIN rail	NS35/15, NS35/7.5 DIN rail
Accessories and spare parts see page 216		

07 b

Technical Drawings – Subject to Alterations

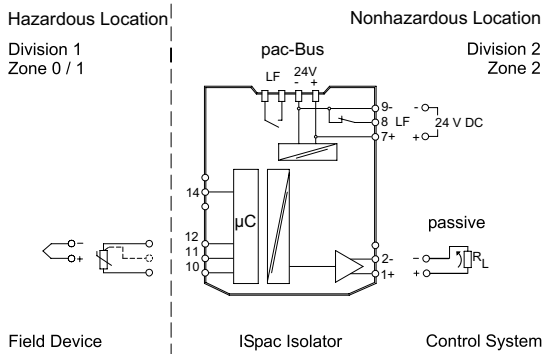

Connection diagram 9182/10-51-11, 9182/10-51-13

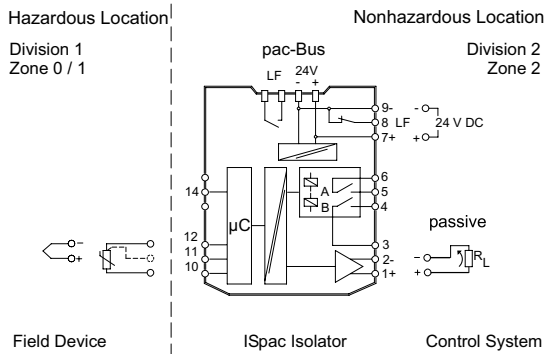

Connection diagram 9182/10-51-12; 9182/10-51-14

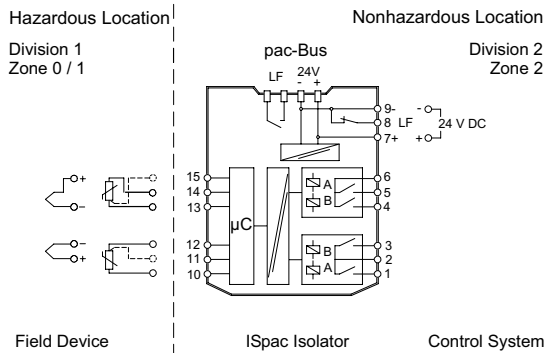

Connection diagram 9182/20-50-12

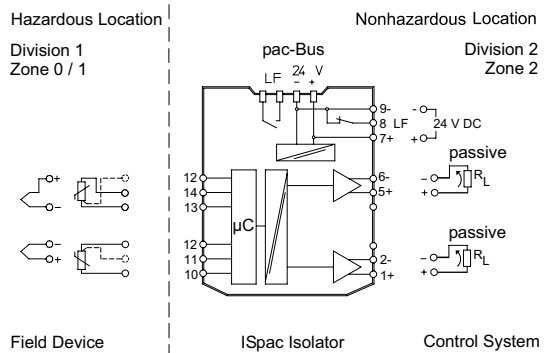

Connection diagram 9182/20-51-11

07b

Dimensional drawings see page 217

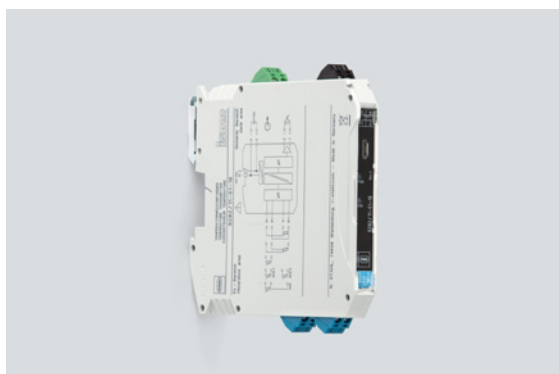

- Ex i temperature transmitter can be configured for virtually any common sensor type
- Space savings due to a slim design – 12.5 mm wide
- Can be used up to SIL 2 (IEC/EN 61508)

WebCode **9282A**



07 b

9282 series temperature transmitters for Ex i field circuits can be used to connect temperature sensors and potentiometers. The devices are easy to configure for virtually any sensor type by means of software. These sensor types include Pt100 sensors, thermocouples and potentiometers. These devices feature three-way galvanic separation.

	NEC® 500 CEC Appendix J					
	Class I		Class II		Class III	
Division	1	2	1	2	1	2
Ex interface	•	•	•	•	•	•
Installation in		•				

	CEC Section 18					
	NEC® 505 Class I			NEC® 506		
Zone	0	1	2	20	21	22
Ex interface	•	•	•			
Installation in			•			

	IECEX / ATEX					
	Zone	0	1	2	20	21
Ex interface	•	•	•	•	•	•
Installation in			•			

Selection Table			
Number of channels	1		
Signal type	Product Type	Art. No.	Weight lb
RTD, potentiometer	9282/11-51-16s	261452	0.37
Thermocouple, mV-source	9282/12-51-16s	261453	0.39
<p>In the scope of delivery of 9282/12-51-16, a Pt100 is included as cold junction compensation, for mounting on the terminal. Alternatively, cold junction compensation 9191/VS-04 is also available (see accessories and spare parts section).</p> <p>The order numbers listed in the table are for devices equipped with screw terminals. Further versions on the Internet r-stahl.com.</p> <p>Parameterization adapter (software is readily available to download online at r-stahl.com, WebCode: 9282A), see accessories and spare parts page 216</p>			

Technical Data		
Variant	9282/11-51-16s	9282/12-51-16s
Explosion Protection		
USA certificate UL	pending	pending
CAN certificate UL	pending	pending
IECEX gas explosion protection	Ex ec ic [ia Ga] IIC T4 Gc	Ex ec ic [ia Ga] IIC T4 Gc
IECEX dust explosion protection	[Ex ia Da] IIIC	[Ex ia Da] IIIC
IECEX firedamp protection	Ex [Ex ia Ma] I	Ex [Ex ia Ma] I
Certificates	ATEX (IBE), IECEX (IBE)	ATEX (IBE), IECEX (IBE)
Ship approval	DNV GL	DNV GL

Technical Data		
Variant	9282/11-51-16s	9282/12-51-16s
Safety Data		
Max. voltage U_0/V_{oc}	6 V	6 V
Max. current I_0/I_{sc}	16.8 mA	16.8 mA
Max. power P_0	25.2 mW	25.2 mW
Safety-related maximum voltage	253 V	253 V
Functional Safety		
SIL	2	2
Auxiliary Power		
Auxiliary power	24 V DC	24 V DC
Input		
Input thermocouple	—	J, K, E, R, S, T, B, N (IEC 584), C, D (ASTM), U, L (DIN 43710), L, A1, A2, A3, M (GOST 8.585)
Input resistance temperature detector (RTD)	Pt 50, Pt 100, Pt 200, Pt 500, Pt 100S, Pt 500S, Ni 100, Ni 500, Cu 50, Cu 53	—
Input resistance temperature detector (RTD) Connection type	2-, 3-, 4-wire connection	—
Input potentiometer	up to 50 k Ω	—
Output		
Output	0/4 ... 20 mA active / source	0/4 ... 20 mA active / source
Load resistance R_L max.	600 Ω	600 Ω
Ambient Conditions		
Ambient temperature °F	-40°F ... +158°F	-40°F ... +158°F
Ambient temperature °C	-40 °C ... +70 °C	-40 °C ... +70 °C
Storage temperature °F	-40°F ... +176°F	-40°F ... +176°F
Storage temperature °C	-40 °C ... +80 °C	-40 °C ... +80 °C
Mounting / Installation		
Mounting type	NS35/15, NS35/7.5 DIN rail	NS35/15, NS35/7.5 DIN rail

Accessories and spare parts see page 216; Dimensional drawings see page 217

07 b

Technical Drawings – Subject to Alterations

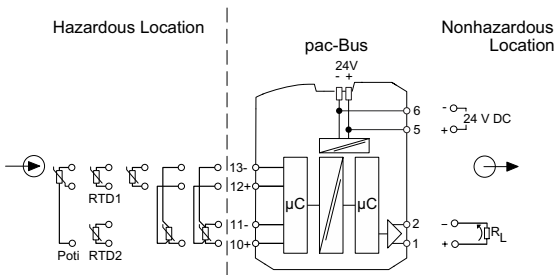

Connection diagram 9282/11-51-16

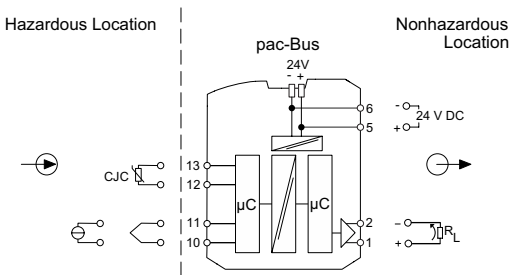

Connection diagram 9282/12-51-16



- Multiplexers for HART field devices with 32 channels
- Simple application: HART Mux master and HART Mux slave in one device
- Can be used up to SIL 3

WebCode 9192A



07 b

The 9192 series HART multiplexer can connect up to 32 HART-capable field devices, such as transmitters or control valves, to asset management systems via RS-485 bus. The HART multiplexer is the ideal solution if you want to operate asset management systems and distributed control systems from different manufacturers in parallel or for enabling HART communication when using a PLC.

	NEC® 500 CEC Appendix J					
	Class I		Class II		Class III	
Division	1	2	1	2	1	2
Ex interface						
Installation in		•				

	CEC Section 18					
	NEC® 505 Class I			NEC® 506		
Zone	0	1	2	20	21	22
Ex interface						
Installation in			•			

	IECEX / ATEX					
	Zone	0	1	2	20	21
Ex interface						
Installation in			•			

Selection Table

Product Description	HART multiplexer ISpac		
Product Type	Art. No.	Weight lb	
9192/32-10-10	160695	0.22	
- incl. 14-core connection cable for pac-Carrier Series 9195 or HART connection board Series 9196 - HART connection board or pac-Carrier required - CommDTM available, download under the given WebCode 9192A			

Technical Data

Explosion Protection	
USA certificate FM	FM16US0122X
CAN certificate FM	FM16CA0067X
USA marking FM	Class I, Div. 2, Groups A,B,C,D; Class I, Zone 2, Group IIC; T4 at Ta = 70°C; See Doc. 91 926 01 31 1
CAN marking FM	Class I, Div. 2, Groups A,B,C,D; Class I, Zone 2, Group IIC; T4 at Ta = 70°C; See Doc. 91 926 01 31 1
IECEX gas explosion protection	Ex nA IIC T4 Gc
Certificates	ATEX (BVS), Brazil (ULB), Canada (FM), IECEX (BVS), India (PESO), SIL (exida), USA (FM)
Ship approval	CCS, DNV GL
Electrical Data	
Connection RS485 Interface	Sub-D socket, 9-pole

Technical Data	
Electrical Data	
Protocol RS-485 Interface	Compatible with Cornerstone Occupational safety & health management system PDM PRM FDM
HART-multiplexer RS-485 interface	Max. 31 (per bus segment)
Number of RS-485 interfaces	1
Number of channels field device interface (HART)	16 or 32, setting via switch
Connection field device interface (HART)	Ribbon cable, 14-pole (included)
Signal field device interface (HART)	HART FSK
Specification field device interface (HART)	HART Field Communication Protocol Rev. 7.x (downwards compatible to Rev. 4.0); FSK Physical Layer Specification (Rev. 7.x)
Auxiliary Power	
Auxiliary power	24 V DC
Ambient Conditions	
Ambient temperature °F	-4°F ... +158°F (Single device) -4°F ... +140°F (Group assembly)
Ambient temperature °C	-20 °C ... +70 °C (Single device) -20 °C ... +60 °C (Group assembly)
Storage temperature °F	-40°F ... +176°F
Storage temperature °C	-40 °C ... +80 °C
Mounting / Installation	
Mounting type	DIN rail (NS35/15, NS35/7.5)
Accessories and spare parts on the Internet r-stahl.com	

07b

Technical Drawings – Subject to Alterations

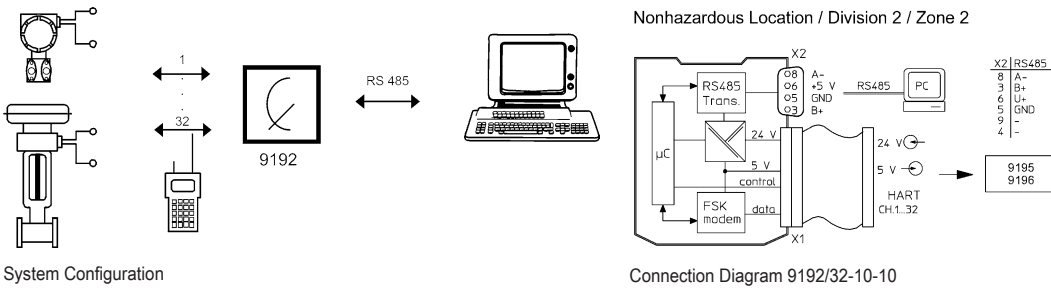

Dimensional Drawings (All Dimensions in mm [inches]) – Subject to Alterations

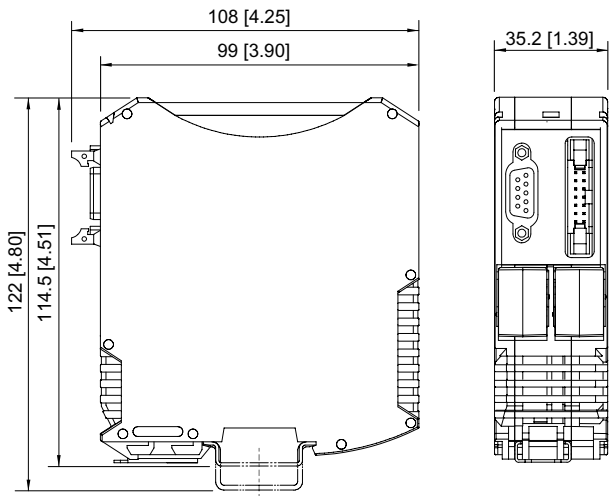

07 b



- Redundant supply for increased availability
- DIP switch makes adjusting operating statuses easy
- Can be used for ISpac Series 91xx und 92xx

WebCode 9193A

The 9193 series supply module supplies the pac-bus with auxiliary power and reads any line fault messages or auxiliary power failures for all of the ISpac devices installed on the pac-Bus. The supply current of up to 4 A is sufficient for approximately 30-50 modules. Power can be supplied using a single or redundant system. The device is provided with an interchangeable fuse.

07b

	NEC® 500 CEC Appendix J					
	Class I		Class II		Class III	
Division	1	2	1	2	1	2
Ex interface						
Installation in						

	CEC Section 18					
	NEC® 505			NEC® 506		
	Class I					
Zone	0	1	2	20	21	22
Ex interface						
Installation in						

	IECEX / ATEX					
	Class I		Class II		Class III	
Zone	0	1	2	20	21	22
Ex interface						
Installation in						

Selection Table				
Product Description	Supply module ISpac			
Supply	Product Type	Art. No.	Weight lb	
24 V / 4 A, primary + redundant	9193/21-11-11s	268183	0.3	

The order numbers listed in the table are for devices equipped with screw terminals.
Further versions on the Internet r-stahl.com

Technical Data	
Auxiliary Power	
Auxiliary power	24 V DC
Auxiliary power voltage range	18 ... 31.2 V
Output	
Output	24 V / max. 4 A, supply via pac-Bus
Collective error message	35 V / 100 mA relay contact
Ambient Conditions	
Ambient temperature °F	-40°F ... +158°F (Single device) -40°F ... +131°F (Group assembly)
Ambient temperature °C	-40 °C ... +70 °C (Single device) -40 °C ... +55 °C (Group assembly)
Storage temperature °F	-40°F ... +176°F
Storage temperature °C	-40 °C ... +80 °C
Mounting / Installation	
Mounting type	NS35/15, NS35/7.5 DIN rail

Accessories and spare parts see page 216

Technical Drawings – Subject to Alterations

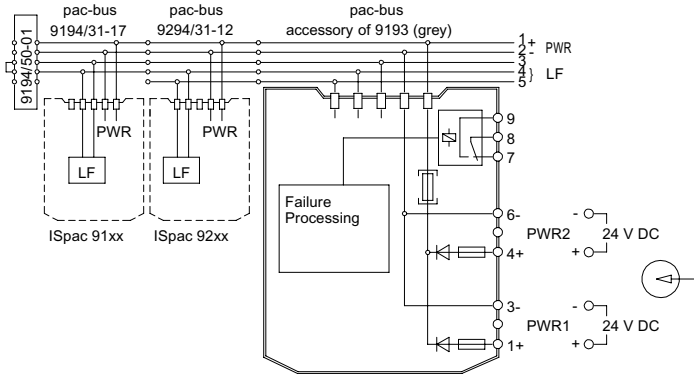

Dimensional drawings see page 217

07 b

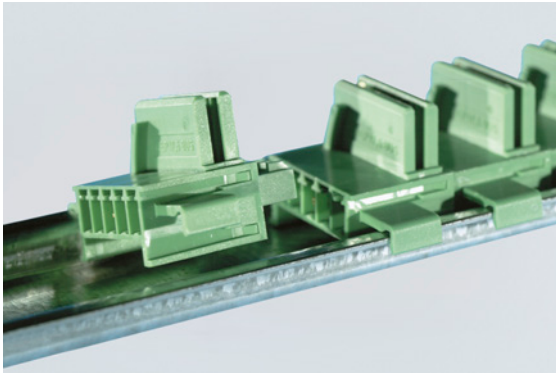

- ISpac devices are quick to wire, reducing costs
- Can be installed on standard DIN rails without tools by simply snapping into place – can be expanded at any time
- Suitable for industrial environments subject to vibration

WebCode **9194A**



The 9194 series pac-Bus supplies 30 to 50 ISpac devices of the 91xx series per pac-Bus segment with auxiliary power and receives error messages from these devices via a zero-potential contact. It is quick and easy to install on high- or low-profile DIN rails without the need for tools, and can be expanded at any time. The system is mechanically very robust, making it perfect for industrial environments. The pac-Bus 9194/31-17 can be combined with pac-Bus 9294/31-12.

07b

	NEC® 500 CEC Appendix J					
	Class I		Class II		Class III	
Division	1	2	1	2	1	2
Ex interface						
Installation in		•				

	CEC Section 18					
	NEC® 505			NEC® 506		
	Class I					
Zone	0	1	2	20	21	22
Ex interface						
Installation in			•			

	IECEX / ATEX					
	Class I		Class II		Class III	
Zone	0	1	2	20	21	22
Ex interface						
Installation in			•			

Selection Table						
Product Description		pac-Bus single element ISpac				
Figure	Description	Grid dimension	Product Type	Art. No.	Weight lb	
	Wiring auxiliary power and collective error message	17.6 mm	9194/31-17	160731 ▲	0.01	
Product Description		pac-Bus terminal set ISpac				
Figure	Description	Grid dimension	Product Type	Art. No.	Weight lb	
	For the supply of 24 V DC auxiliary power via terminals (alternative to using the supply module 9193/21-11-11), with jumper for error message chain for ISpac module 91xx	–	9194/50-01	160730 ▲	0.02	

Technical Data	
Explosion Protection	
USA certificate FM	FM16US0122X
CAN certificate FM	FM16CA0067X
USA marking FM	Class I, Div. 2, Groups A,B,C,D; Class I, Zone 2, Group IIC; T4 at Ta = 70°C; See Doc. 91 956 01 31 1
CAN marking FM	Class I, Div. 2, Groups A,B,C,D; Class I, Zone 2, Group IIC; T4 at Ta = 70°C; See Doc. 91 956 01 31 1

Technical Data	
Explosion Protection	
IECEX gas explosion protection	Ex nA IIC T4 Gc
Certificates	ATEX (BVS), Brazil (ULB), Canada (FM), IECEx (BVS), India (PESO), USA (FM)
Ship approval	CCS, DNV GL
Electrical Data	
Connections	using pac-Bus terminal set 9194/50-01 or supply module 9193/21-11-11.
Mounting / Installation	
Mounting type	NS35/15, NS35/7.5 DIN rail
Mounting position	Horizontal Vertical

Technical Drawings – Subject to Alterations

07 b

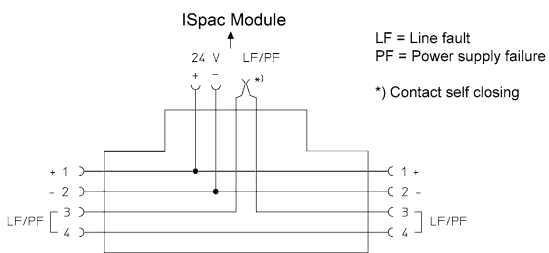

Connection Diagram 9194/50-01

Dimensional Drawings (All Dimensions in mm [inches]) – Subject to Alterations

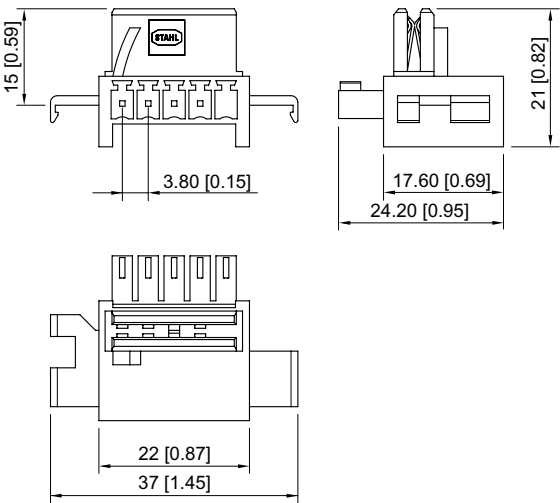

Series 9194

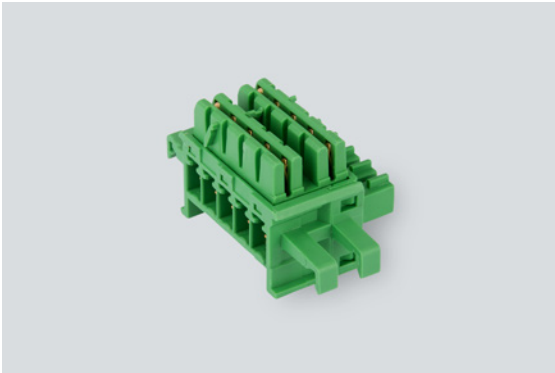

- ISpac devices are quick to wire, reducing costs
- Can be installed on standard DIN rails without tools by simply snapping into place – can be expanded at any time
- Suitable for industrial environments subject to vibration

WebCode 9294A

The pac-Bus 9294/31-12 supplies 30 to 50 ISpac devices of series 92xx. The auxiliary power can be fed into the pac-Bus segment via the terminal set 9194/50-01. The supply module 9193/21-11-11 can alternatively be used for a redundant supply and for reading out the collective error message. The pac-Bus can be clipped onto DIN rails NS 35/15 and NS35/7.5. The pac-Bus 9294/31-12 can be combined with pac-Bus 9194/31-17.

07 b

	NEC® 500 CEC Appendix J					
	Class I		Class II		Class III	
Division	1	2	1	2	1	2
Ex interface						
Installation in						

	CEC Section 18					
	NEC® 505 Class I			NEC® 506		
Zone	0	1	2	20	21	22
Ex interface						
Installation in						

	IECEX / ATEX					
	Zone	0	1	2	20	21
Ex interface						
Installation in						

Selection Table						
Product Description						
pac-Bus single element ISpac						
Figure	Description	Grid dimension	Product Type	Art. No.	Weight lb	
	Wiring for power supply and common error messaging	12.5 mm	9294/31-12	262928 ▲	0.01	

Technical Data	
Electrical Data	
Connections	using pac-Bus terminal set 9194/50-01 or supply module 9193/21-11-11.
Mounting / Installation	
Mounting position	Horizontal Vertical
Mounting type	NS35/15, NS35/7.5 DIN rail

Dimensional Drawings (All Dimensions in mm [inches]) – Subject to Alterations

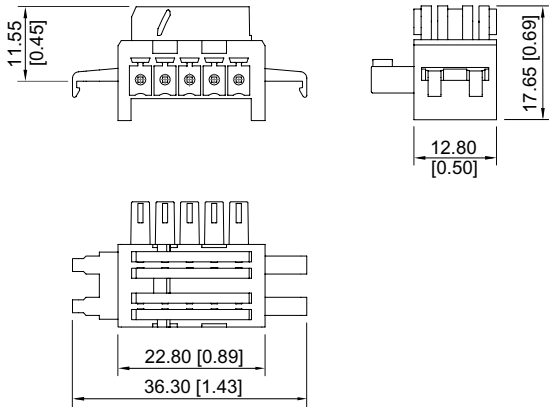

Series 9294

07 b



- Prefabricated system cables for field terminal boards (FTB) make it quick and easy to install – simply snaps onto a DIN rail or mounting plate
- Can be used with the Emerson Delta V, Schneider Foxboro/Tricon, Honeywell C300, Siemens ET200M and ET200F, Yokogawa Centum VP and ProSafe-RS
- All ISpac isolators 91xx can be used in the pac-Carrier

WebCode 9195A



The 9195 series pac-Carrier is a cost-effective solution allowing Ex i field devices to be connected to common I/O modules of distributed control systems and programmable logic controllers. The extremely robust carrier is suitable for 8 or 16 standard ISpac isolators and can process 32 signals, including a combination of Ex i and non-Ex i signals. It can be adapted to accommodate new I/O modules at any time. The carrier can be combined with the 9192 series HART Mux.

07 b

	NEC® 500 CEC Appendix J					
	Class I		Class II		Class III	
Division	1	2	1	2	1	2
Ex interface						
Installation in		•				

	CEC Section 18 NEC® 505 NEC® 506					
	Class I					
Zone	0	1	2	20	21	22
Ex interface						
Installation in			•			

	IECEx / ATEX					
	Zone	0	1	2	20	21
Ex interface						
Installation in			•			

Selection Table						
Connection HART-multiplexer Connections		Yes via HART multiplexer 9192				
I/O type	Type of signal	Number of slots	Redundancy	Product Type	Art. No.	Weight lb
Any	DI, DO, AI, AO	16	No	9195/16H-XX0-01C	209268	1.86

Customer specific versions for the following DCS: Yokogawa Centum VP, Yokogawa Pro-Safe-RS, Schneider Electric (TRICONEX, Foxboro), Honeywell, Siemens.

Detailed information on available pac-carrier versions and the technical description can be found online at WebCode 9195A.

Technical Data	
Explosion Protection	
USA certificate FM	FM16US0122X
CAN certificate FM	FM16CA0067X
USA marking FM	Class I, Div. 2, Groups A,B,C,D; Class I, Zone 2, Group IIC; T4 at Ta = 70°C; See Doc. 91 956 01 31 1
CAN marking FM	Class I, Div. 2, Groups A,B,C,D; Class I, Zone 2, Group IIC; T4 at Ta = 70°C; See Doc. 91 956 01 31 1
IECEx gas explosion protection	Ex nA nC IIC T4 Gc
Certificates	ATEX (BVS), Brazil (ULB), Canada (FM), IECEx (BVS), India (PESO), SIL (exida), USA (FM)
Ship approval	CCS, DNV GL

Technical Data

Electrical Data

Number of channels field device interface (HART)	8, 16, 32
Fuse	2 x TR5; T 2 A; exchangeable, for primary and redundant supply

Auxiliary Power

Auxiliary power	24 V DC
Redundant supply	yes, decoupled with diodes

Input

Line fault and loss of power signalization	Contact (30 V / 100 mA) closed to ground in case of fault pac-Bus, floating contact (30 V / 100 mA)
--	--

Ambient Conditions

Ambient temperature °F	-4°F ... +158°F
Ambient temperature °C	-20 °C ... +70 °C
Storage temperature °F	-40°F ... +176°F
Storage temperature °C	-40 °C ... +80 °C

Mounting / Installation

Mounting orientation	horizontal or vertical
Mounting type	DIN rail or wall mounting

Accessories

Figure	Description	Product Type	Art. No.	Weight lb
	The "Dummy Module" is used for the connection of unused cable. There is no electrical connection between input and output terminal.	9191/20-00-00	160674	0.13

Technical Drawings – Subject to Alterations

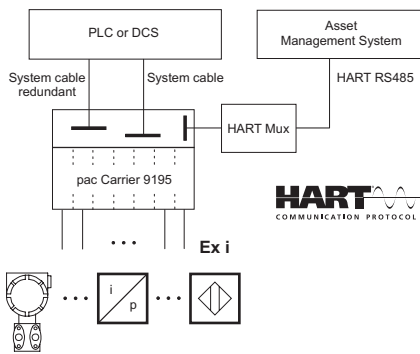

System configuration

Dimensional Drawings (All Dimensions in mm [inches]) – Subject to Alterations

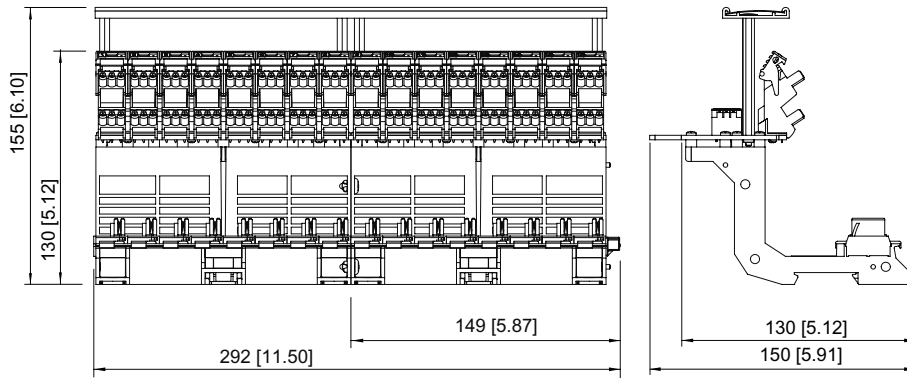

Type 9195/16.-...-..., 16 slots

07 b

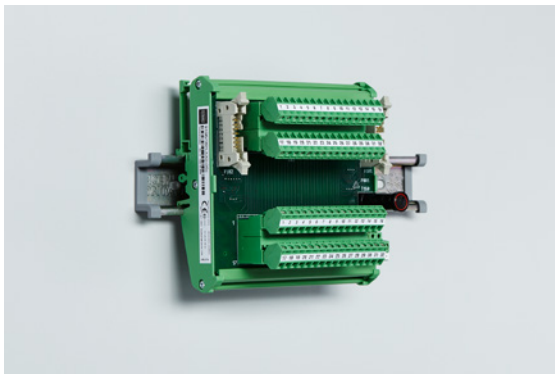

- Cost- and space-saving system for HART communication
- Different variants available with or without signal conversion
- Easy to install on DIN rails

WebCode **9196A**



07 b

Used in combination with the HART multiplexer (9192), the 9196 series HART termination board enables the transmission of data using the HART protocol between field devices and an asset management system. The boards are very easy to install on DIN rails and can process 4 to 20 mA signals with HART FSK. If Ex i separation is necessary, this will require separate Ex i isolators.

	NEC® 500 CEC Appendix J					
	Class I		Class II		Class III	
Division	1	2	1	2	1	2
Ex interface						
Installation in		•				

	CEC Section 18					
	NEC® 505 Class I			NEC® 506		
Zone	0	1	2	20	21	22
Ex interface						
Installation in			•			

	IECEX / ATEX					
	Zone	0	1	2	20	21
Ex interface						
Installation in			•			

Selection Table				
Connection isolators / Non-Ex field devices	via pluggable terminal; connected to the field device in parallel / automation system; in or output			
Signal to the control system	Terminal	Product Type	Art. No.	Weight lb
4 ... 20 mA	One terminal for field and control system side, detachable	9196/16H-XX0-03c	160891	0.33
Connection isolators / Non-Ex field devices Connection automation system	via pluggable terminal; connected to the field device in parallel / automation system; in or output via integrated screw terminal			
Signal to the control system	Terminal	Product Type	Art. No.	Weight lb
4 ... 20 mA	One terminal for field side, one terminal for control system side, detachable	9196/16H-XX0-05c	249297	1.15
32 channels if two HART termination boards Series 9196 are connected to HART multiplexer Series 9192.				

Technical Data	
Explosion Protection	
USA certificate FM	FM16US0122X
CAN certificate FM	FM16CA0067X
USA marking FM	Class I, Div. 2, Groups A,B,C,D; Class I, Zone 2, Group IIC; T4 at Ta = 70°C; See Doc. 91 926 01 31 1
CAN marking FM	Class I, Div. 2, Groups A,B,C,D; Class I, Zone 2, Group IIC; T4 at Ta = 70°C; See Doc. 91 926 01 31 1
IECEX gas explosion protection	Ex nA IIC T4 Gc

Technical Data	
Explosion Protection	
Certificates	ATEX (BVS), Brazil (ULB), Canada (FM), IECEx (BVS), India (PESO), SIL (exida), USA (FM)
Ship approval	CCS, DNV GL
Auxiliary Power	
Auxiliary power	24 V DC
Ambient Conditions	
Ambient temperature °F	-4°F ... +158°F
Ambient temperature °C	-20 °C ... +70 °C
Storage temperature °F	-40°F ... +176°F
Storage temperature °C	-40 °C ... +80 °C
Mounting / Installation	
Mounting type	DIN rail (NS35/15, NS35/7.5)

Technical Drawings – Subject to Alterations



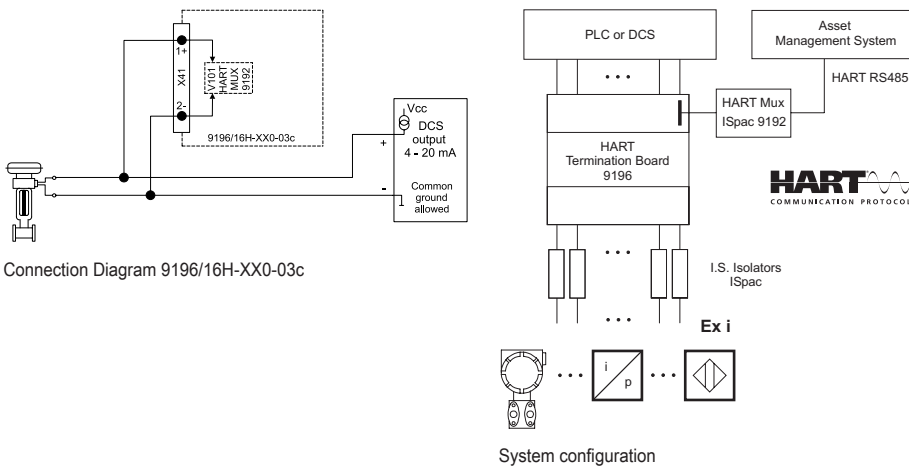

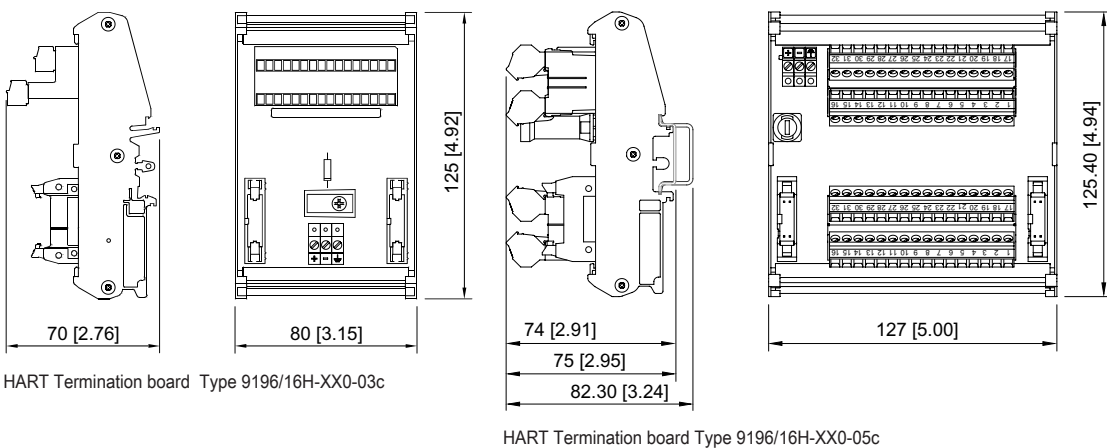

07b



Dimensional Drawings (All Dimensions in mm [inches]) – Subject to Alterations



07 b

Accessories				
Figure	Description	Product Type	Art. No.	Weight lb
External reference junction				
	External reference junction for 2 x thermocouple (1 x Pt100 for 2, 3 or 4 wire connection) integrated into the 4-pole. terminal block. Installation takes place on the DIN rail.	9191/VS-04	160675	0.07 lb
	External reference junction for 1 x thermocouple (Pt100 in 2 wire connection) integrated into the plug-gable terminal (3-pole). Installation takes place in the ISpac device instead of the standard terminal.	9191/VS-05	160676	0.07 lb
ISpac "Dummy Module"				
	The "Dummy Module" is used for the connection of unused cable. There is no electrical connection between input and output terminal.	9191/20-00-00	160674	0.13 lb
Front cover				
	for ISpac modules 91xx yellow, transparent Clear marking of the device for SIL applications. (Packaging unit: 10 pieces)	-	200914	0.04 lb
Resistance coupling element				
	Connection of additional contacts in the Ex area as well, in order to enable short circuit and open circuit detection.	-	105944	0.02 lb
Parameterization set ISpac - Wizard				
	The software serves for commissioning, configuring and diagnosing the ISpac isolators Series 9146, 9162, 9182 and 9282. For further information, see operating instructions. Form of delivery: USB stick; parameterization software incl. parameterization cable / adaptor System requirements: IBM compatible PC with MS XP, Vista, Windows 7, 10 RS 232 C interface RS 232 / USB adaptor	-	202595	0.52 lb
Parameterization adapter				
	Used for parameterization and diagnostics on 9282 series ISpac isolators. Interface to PC: USB Scope of delivery: Adapter and cable (software is available to download online at r-stahl.com, WebCode: 9282A)	-	261507	0.35 lb

Dimensional Drawings (All Dimensions in mm [inches]) – Subject to Alterations

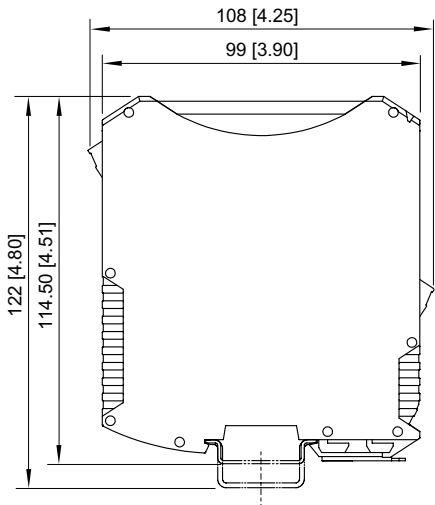

ISpac Series 9185, 9192 with screw terminal

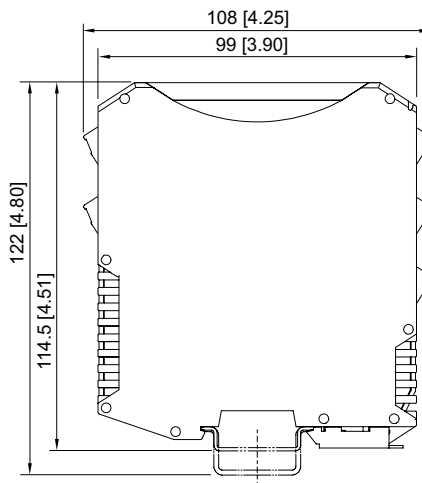
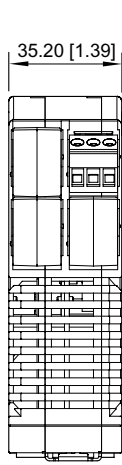

ISpac Series 9146, 9147, 9160, 9162, 9163, 9165, 9167, 9170, 9172, 9175, 9176, 9180, 9182, 9193 with screw terminal

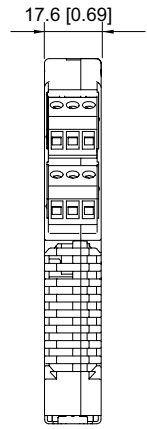

07 b

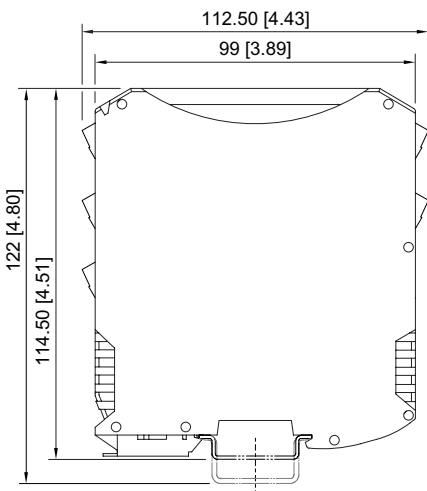

ISpac Series 9260, 9265, 9270, 9275, 9276, 9282 with screw terminal

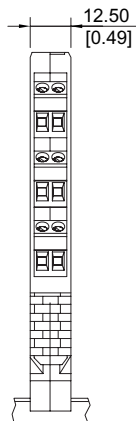

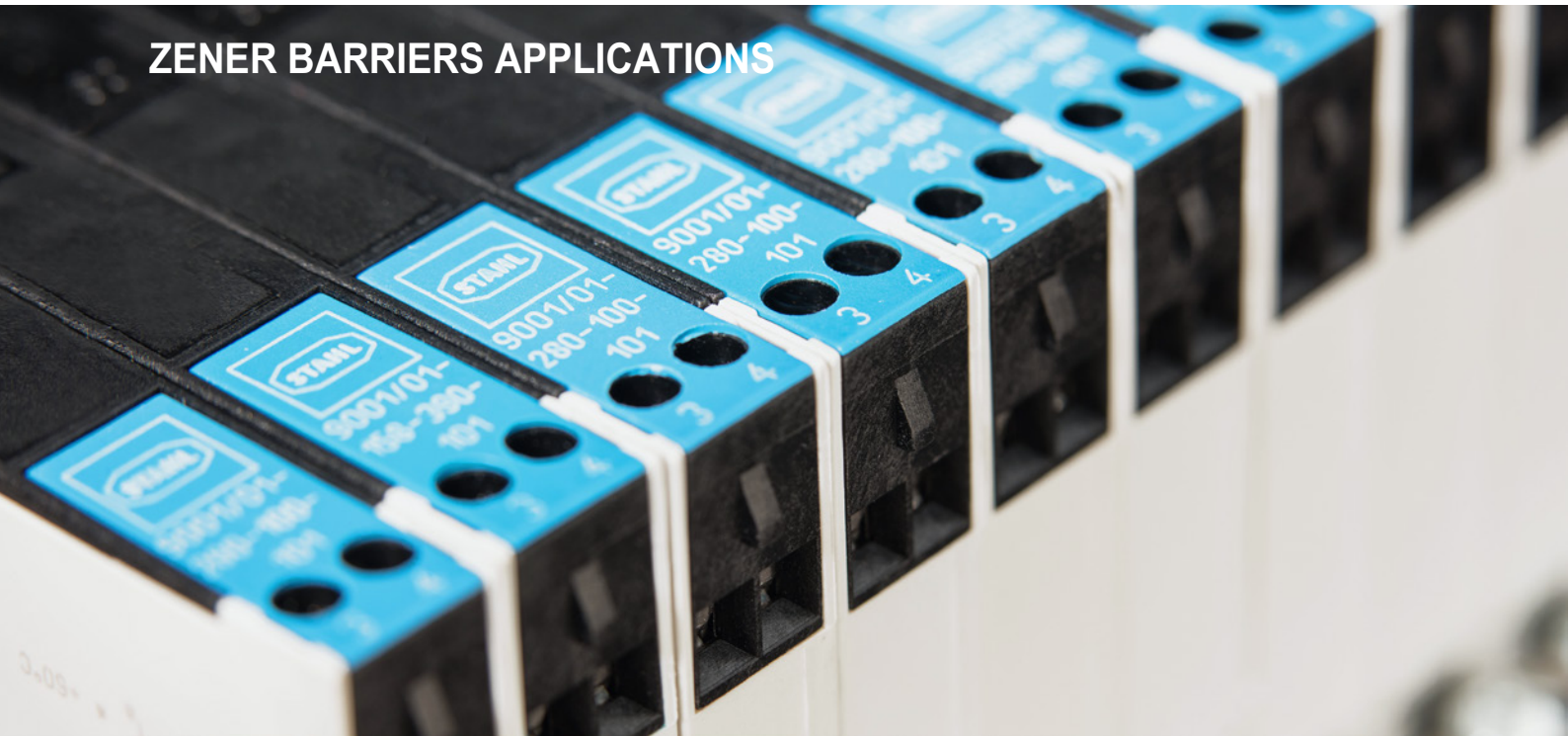

ZENER BARRIERS APPLICATIONS

Product	Series	Page	WebCode
Application Information			
Applications 2-wire Discrete Input from Dry Contacts		220	
Applications 2-wire Discrete Output for Solenoids, LEDs and Audible Alarms		223	
Applications 2-wire NAMUR Proximity Sensors		221	
Applications 2-wire, 4/20 mA I/P Converters and Control Valves		219	
Applications 2-wire, 4/20 mA Transmitters - Standard and HART		219	
Applications 3-wire PNP Inputs (Negative Switching) from Proximity Sensors, Photocells and Encoders		222	
Applications 3-wire PNP Inputs (Positive Switching) from Proximity Sensors, Photocells and Encoders		222	
Applications Data Communication		229	
Applications DC Potentiometers		228	
Applications Displacement Sensors		228	
Applications RTDs		226	
Applications Strain Gauge Load Cells		225	
Applications Thermocouples		228	
Applications Voltage Pulse Inputs		224	

For additional products and information please refer to r-stahl.com

2-wire, 4/20 mA Transmitters – Standard and HART

Order Code	Schematic
------------	-----------

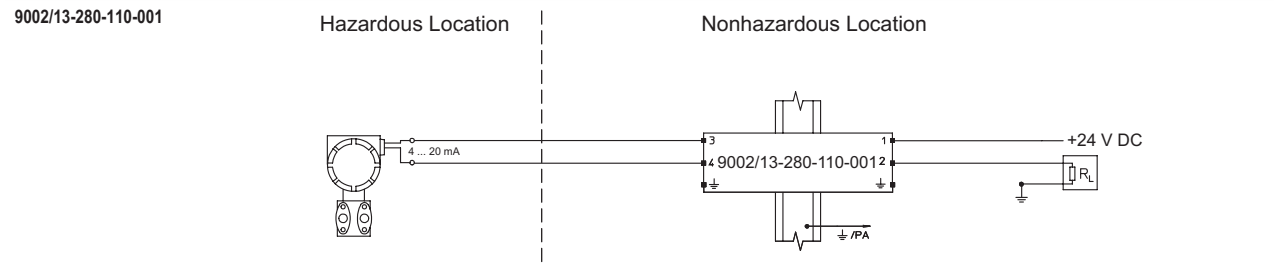

Application Note This zener barrier provides an economical solution when regulated 24 V DC power supplies are used. The nonhazardous load should be $\leq 250 \Omega$ and the minimum operating voltage of the transmitter should be $\leq 11 \text{ V DC}$.

2-wire, 4/20 mA I/P Converters and Control Valves – Standard and HART, 4/20 mA Digital Indicators

Order Code	Schematic
------------	-----------

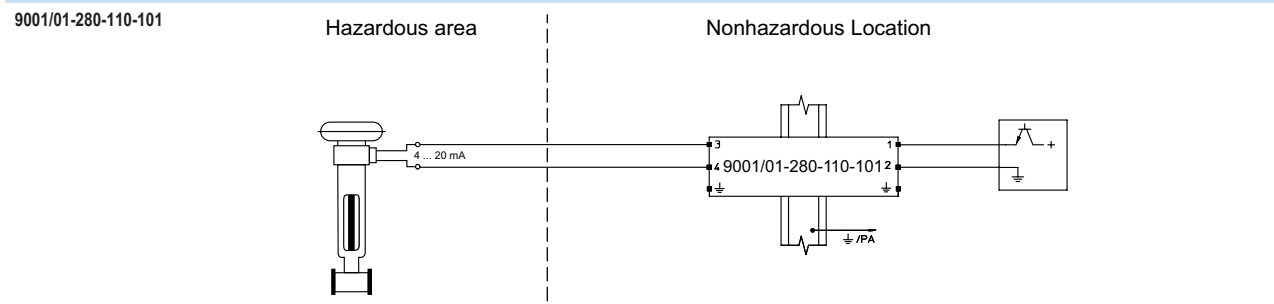

Application Note This zener barrier is for use when the control system regulates the output in the supply line. The field device and control system are both connected to ground and a regulated power supply must be used. At a nominal operating current of 0 ... 22 mA the maximum volt drop across the barrier will be 6.5 V.

Order Code	Schematic
------------	-----------

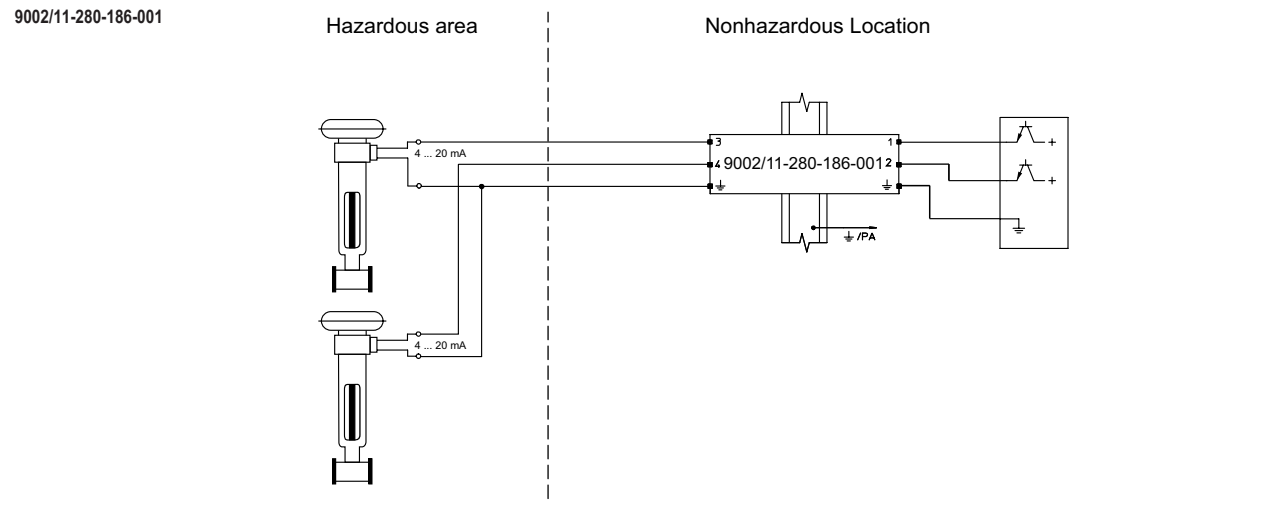

Application Note This zener barrier is for use with two independent field devices when the control system regulates the output in the supply line. The field devices and control system are both connected to ground and a regulated power supply must be used. At a nominal operating current of 0 ... 22 mA the maximum volt drop across each channel of the barrier will be 7.9 V.

08 a

Order Code Schematic

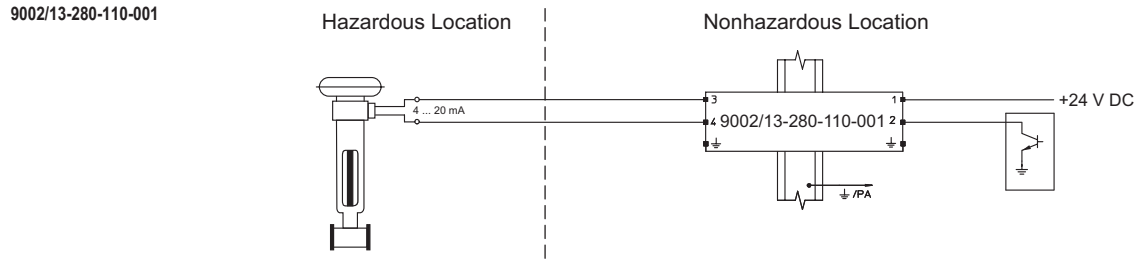

Application Note This zener barrier is for use when the control system regulates the output in the return (negative) line. The field device and control system are both floating and a regulated power supply must be used. At a nominal operating current of 0 ... 22 mA the maximum volt drop across the barrier will be 8.4 V.

2-wire Discrete Input from Dry Contacts

Order Code Schematic

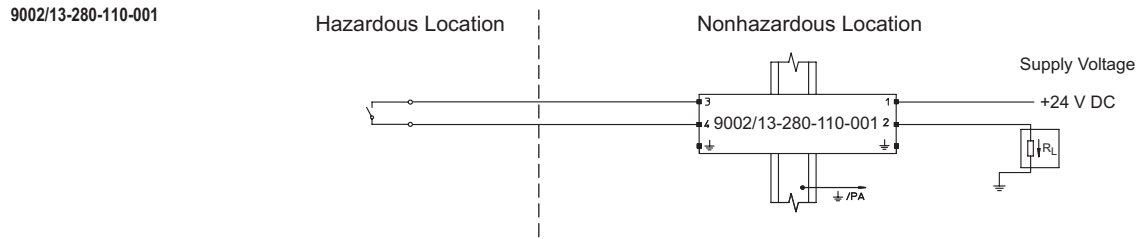

Application Note This zener barrier can be used in a fail safe application as the return (signal) wire is not connected to ground. In this application, when using zener barriers with an electromechanical relay in the nonhazardous location, it is important to select a relay with the following characteristics:
 1. Approx. 1/2 the supply voltage
 2. Resistance \geq to that of the barrier chosen
 i.e. 12 V, 300 Ω

Order Code Schematic

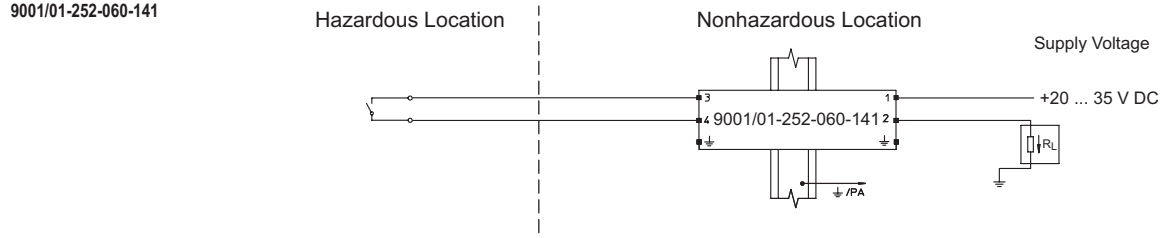

Application Note These zener barriers are application specific for dry contacts and are suitable for driving relays or optocoupler inputs of an automation system. The supply voltage is +20 ... 35 V and the voltage available for the relay is $V_{supply} - 3 V$. The return (signal) wire of the dry contact is connected to ground and therefore these barriers should not be used in fail safe applications. This barrier has a load connected in the return (signal) line.

08 a

Order Code Schematic

9002/13-280-110-001
plus 9002/33-280-000-001
or 9001/03-280-000-101

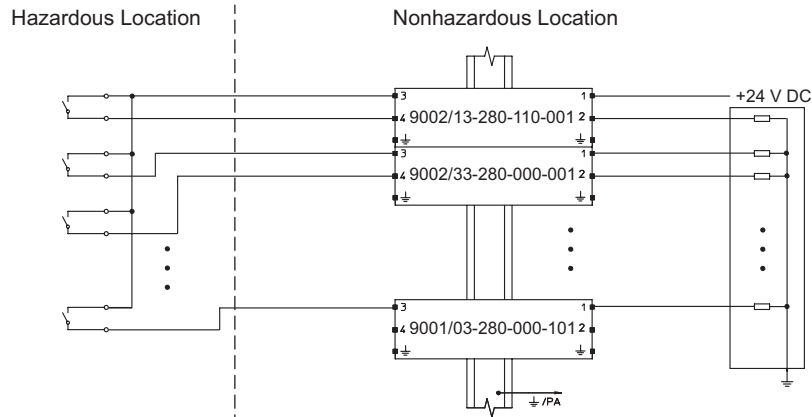

9001/01-280-110-001
plus 9002/33-280-000-001
or 9001/03-280-000-101

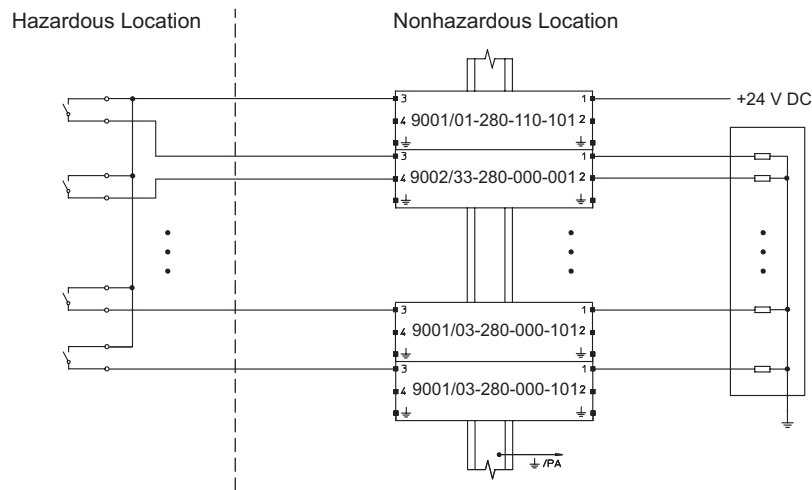

08 a

Application Note

These barriers can be used together for applications where multiple switches are used with a common power supply. The combination of barriers depends on the number of switches to be used. To measure the voltage, in these applications, the input in the non-hazardous location must have a high impedance ($\geq 3 \text{ k}\Omega$). In this application, care should also be taken to calculate the combined entity Parameters of the barriers to ensure that it remains a safe combination in the gas group in which it is to be used. Always remember to keep it as simple as possible.

2-wire NAMUR Proximity Sensors

Application Note

It is recommended to use galvanic isolators, Series 9270, instead of zener barriers for this application.

3-wire PNP Inputs (Positive Switching) from Proximity Sensors, Photocells and Encoders

Order Code Schematic

9002/13-280-110-001

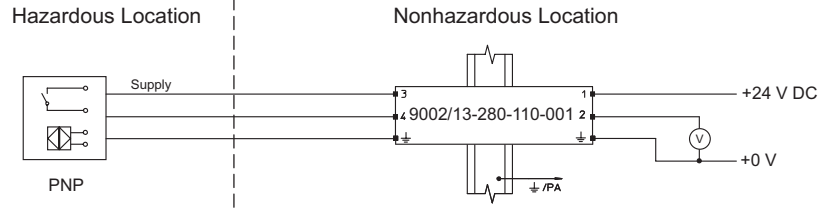

Application Note

These barriers allow a 24 V DC, 300 Ω relay to be used.
The sensor chosen should have a minimum operating voltage of 10 V DC.
It can be used for unregulated power supplies.
All loop voltages must be checked to ensure correct operation.

3-wire PNP Inputs (Negative Switching) from Proximity Sensors, Photocells and Encoders

Order Code Schematic

9002/11-280-186-001

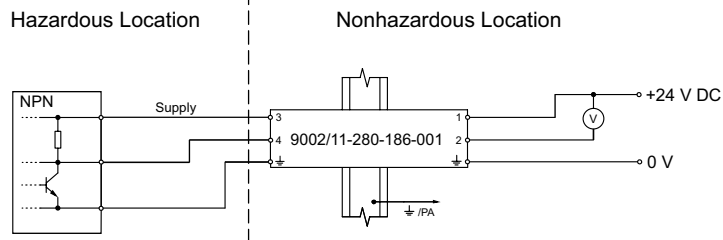



Application Note

The load specification should not exceed 12 V, 30 mA. This installation is not allowed in gas groups A and B. The sensor chosen should have a minimum operating voltage of 10 V DC. With this barrier all loop voltages must be checked to ensure correct operation.

08 a

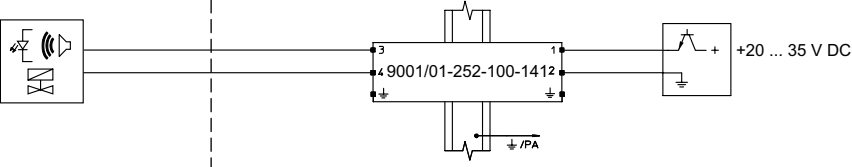
2-wire Discrete Output for Solenoids, LEDs and Audible Alarms

Order Code	Schematic
9001/01-252-100-141	<div style="display: flex; justify-content: space-between;"> <div style="width: 45%;"> <p>Hazardous Location</p>  </div> <div style="width: 45%; border-left: 1px dashed black; padding-left: 10px;"> <p>Nonhazardous Location</p>  </div> </div>
Application Note	<p>This barrier is for use with unregulated power supplies and grounded return lines. Nominal voltage is 20 ... 35 V and when supplied with more than 24 V DC, the open circuit output voltage $V_L = 21$ V. If $V_{nom} \leq 24$ V DC, $V_L = V_{nom} - 3$ V. The operating current depends on the resistance (R_L) of the field device where $I = V_L / (268 \Omega + R_L)$.</p>

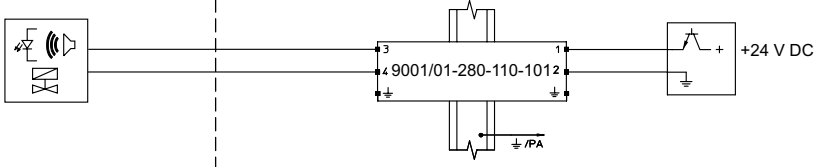
Order Code	Schematic
9001/01-280-110-101	<div style="display: flex; justify-content: space-between;"> <div style="width: 45%;"> <p>Hazardous Location</p>  </div> <div style="width: 45%; border-left: 1px dashed black; padding-left: 10px;"> <p>Nonhazardous Location</p>  </div> </div>
Application Note	<p>This barrier is for use with regulated power supplies and grounded return lines. Nominal voltage is 24 V. For applications that require higher power, for use only in gas groups C and D, then the 9001/01-280-165-101 and 9001/01-280-280-101 may be used.</p>

08 a

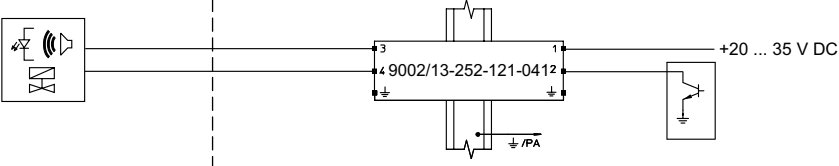
Order Code	Schematic
9002/13-252-121-041	<div style="display: flex; justify-content: space-between;"> <div style="width: 45%;"> <p>Hazardous Location</p>  </div> <div style="width: 45%; border-left: 1px dashed black; padding-left: 10px;"> <p>Nonhazardous Location</p>  </div> </div>
Application Note	<p>This barrier is for use with unregulated power supplies and floating return lines. Nominal voltage is 20 ... 35 V and when supplied with more than 24 V DC, the open circuit output voltage $V_L = 21$ V. If $V_{nom} \leq 24$ V DC, $V_L = V_{nom} - 3$ V. The operating current depends on the resistance (R_L) of the field device where $I = V_L / (243 \Omega + R_L)$.</p>

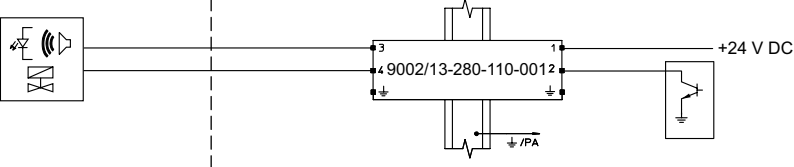
Order Code	Schematic
9002/13-280-110-001	<div style="display: flex; justify-content: space-between;"> <div style="width: 45%;"> <p>Hazardous Location</p>  </div> <div style="width: 45%; border-left: 1px dashed black; padding-left: 10px;"> <p>Nonhazardous Location</p>  </div> </div>
Application Note	<p>This barrier is for use with regulated power supplies and grounded return lines. Nominal voltage is 24 V.</p>

Order Code Schematic

9002/11-280-186-001

Hazardous Location

Nonhazardous Location

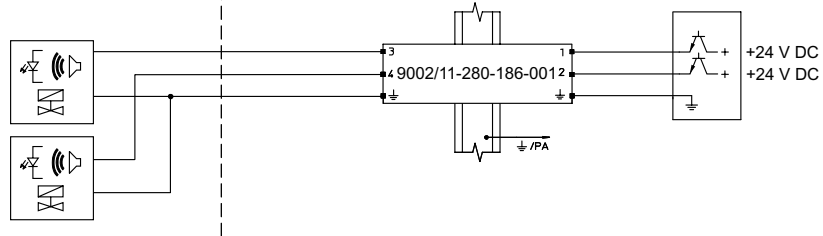

Application Note

This barrier is for use with regulated power supplies and grounded return lines when there are two field devices. Nominal voltage is 24 V.

Voltage Pulse Inputs

08 a

Order Code Schematic

9002/22-240-024-001

Hazardous Location

Nonhazardous Location

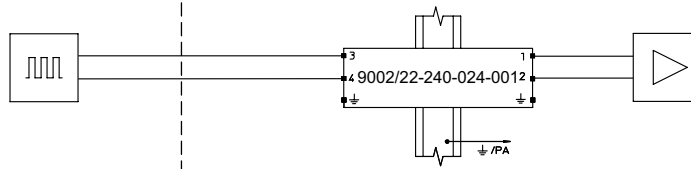

Application Note

This barrier will pass voltage pulse inputs up to 20 V. Maximum switching frequency of 50 kHz

Strain Gauge Load Cells

Order Code Schematic

9002/10-187-270-001
9002/10-187-020-001
9002/77-093-040-001

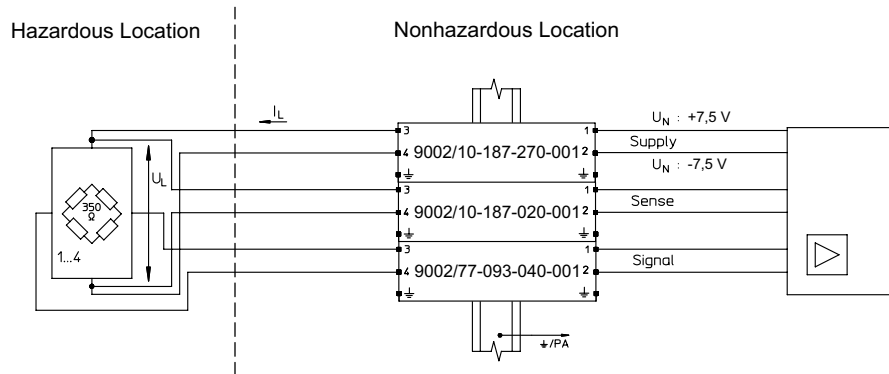

Application Note For use with ± 7.5 V excitation voltage, 350 Ω or 700 Ω strain gauge load cells.

Combination Entity Parameters

	V_{OC}	I_{SC}	P_{max}
With sense:	18.7 V	330 mA	1.45 W
Without sense:	18.7 V	310 mA	1.36 W

Excitation Voltage and Current available at the Strain Gauge

Number of strain gauges in parallel	350 Ω		700 Ω	
	V	mA	V	mA
1	11.6 V	35 mA	13.2 V	19 mA
2	9.6 V	55 mA	11.6 V	35 mA
3	8 V	70 mA	10.6 V	45 mA
4	7 V	80 mA	9.6 V	55 mA

Order Code Schematic

9002/11-130-360-001
9002/11-120-024-001
9002/11-120-024-001

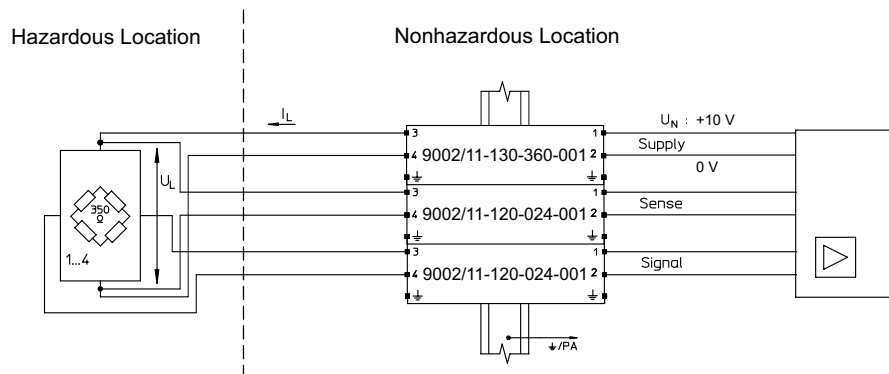

Application Note For use with +10 V excitation voltage, 350 Ω strain gauge load cells.

Combination Entity Parameters

	V_{OC}	I_{SC}	P_{max}
With sense:	13 V	408 mA	1.2 W
Without sense:	13 V	384 mA	1.13 W

Excitation Voltage and Current available at the Strain Gauge

Number of strain gauges in parallel	350 Ω	
	V	mA
1	7.7 V	22 mA
2	6.2 V	35 mA
3	5.2 V	44.5 mA
4	4.5 V	51 mA

08 a

Order Code Schematic

9002/13-199-225-001
 9002/11-199-030-001
 9002/11-199-030-001

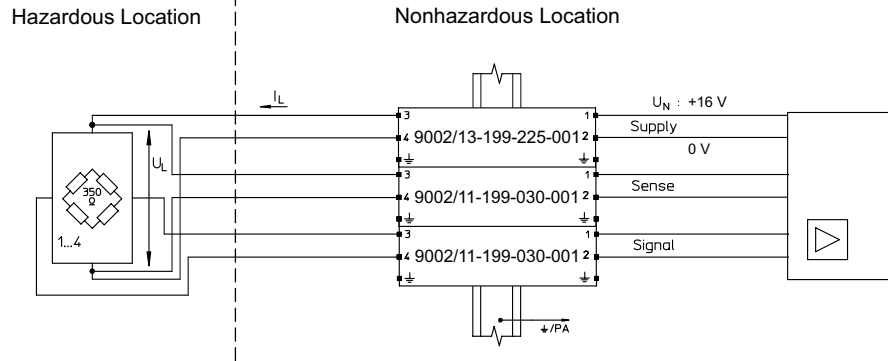

Application Note For use with +16 V excitation voltage, 350 Ω or 700 Ω strain gauge load cells.

Combination Entity Parameters

	V_{OC}	I_{SC}	P_{max}
With sense:	19.9 V	285 mA	1.42 W
Without sense:	19.9 V	255 mA	1.3 W

Excitation Voltage and Current available at the Strain Gauge

Number of strain gauges in parallel	350 Ω		700 Ω	
	V	mA	V	mA
1	10.4 V	30 mA	12.1 V	17 mA
2	8.3 V	47 mA	10.4 V	30 mA
3	6.9 V	60 mA	9.5 V	41 mA
4	5.9 V	67 mA	8.3 V	47 mA

08 a

RTDs

Order Code Schematic

9002/22-032-300-111

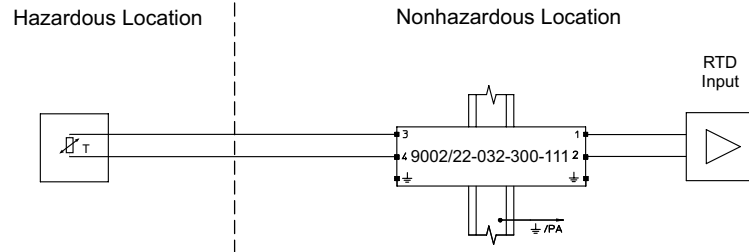

Application Note Although 2-wire RTD circuits are the least accurate when used with zener barriers, due to the additional barrier resistance, the above barrier has a precision resistor with a tolerance of $\pm 0.1 \Omega$ to limit the loss of accuracy. It is recommended to use 3- or 4-wire RTD circuits, with 4-wire RTD circuits maintaining the maximum accuracy.

Order Code Schematic

9002/22-032-300-111
9001/02-016-150-111

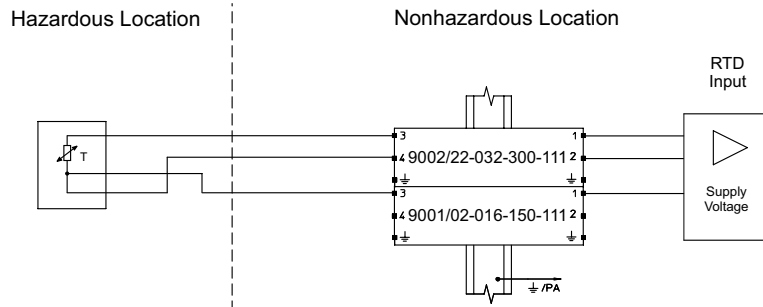

9002/22-032-300-111
9002/22-032-300-111
9002/22-032-300-111

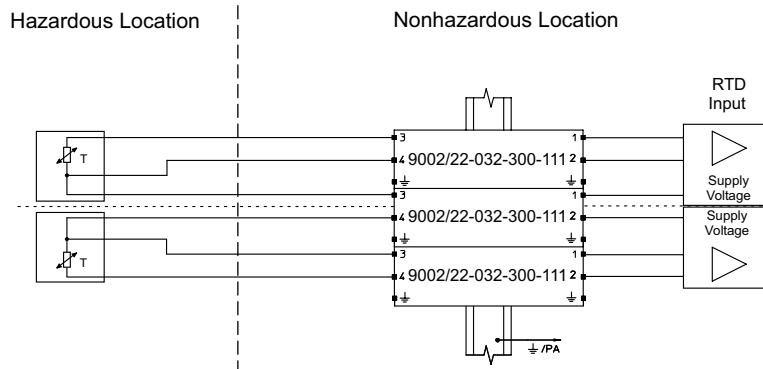

Application Note

For a single 3-wire RTD configuration, the first combination can be used. Where multiple 3-wire RTDs are used, then the second combination is a more economical solution.

Measurement Range

Operating Current ≤	5 mA	3 mA
Temperature ≤	752 °F (400 °C)	1562 °F (850 °C)

Combination Entity Parameters

V_{oc}	I_{sc}
3.2 V	450 mA

Order Code Schematic

9002/22-032-300-111
9002/77-093-040-111

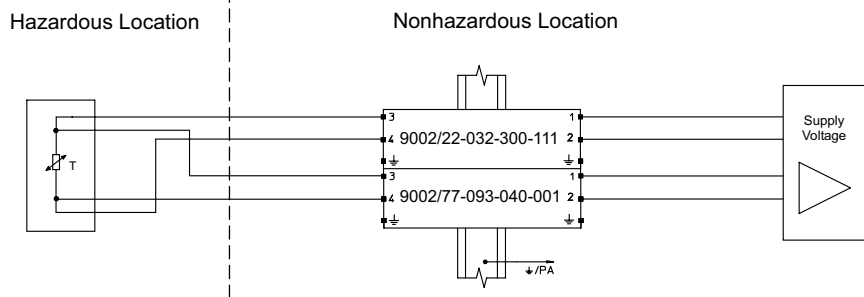

Application Note

For a 4-wire RTD configuration, the combination above is recommended.

Measurement Range

Operating Current ≤	5 mA	3 mA
Temperature ≤	752 °F (400 °C)	1562 °F (850 °C)

Combination Entity Parameters

V_{oc}	I_{sc}
10.9 V	340 mA

08 a

Thermocouples

Order Code Schematic

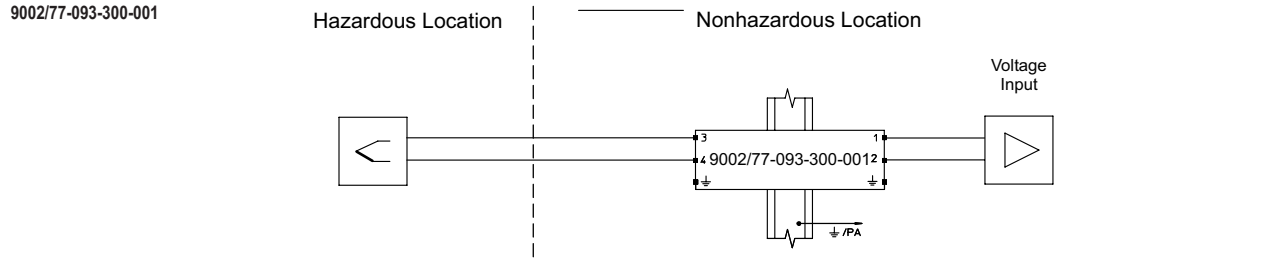

Application Note With zener barriers it is recommended that ungrounded thermocouples be used. For grounded thermocouples it is recommended to use galvanic isolators or a potential equalizing conductor between the thermocouple ground and the barrier ground connections. It is recommended that compensating cable is used on both sides of the zener barrier to compensate for the creation of cold junctions at the barrier terminals. Adequate electrostatic shielding should also be provided to divert any noise that should occur in the circuit. The low resistance of this barrier allows for the connection of any thermocouple type.

08 a

DC Potentiometers

Potentiometer applications with barriers:
For intrinsically safe operation, a comparison must be done to ensure the safe operation of the potentiometer. The power dissipation and surface of the potentiometer must be in accordance with the standards. The potentiometer must be classified to a temperature class.
The galvanic isolators 9180 and 9182 are recommended for potentiometers and both have low power outputs.

Order Code Schematic

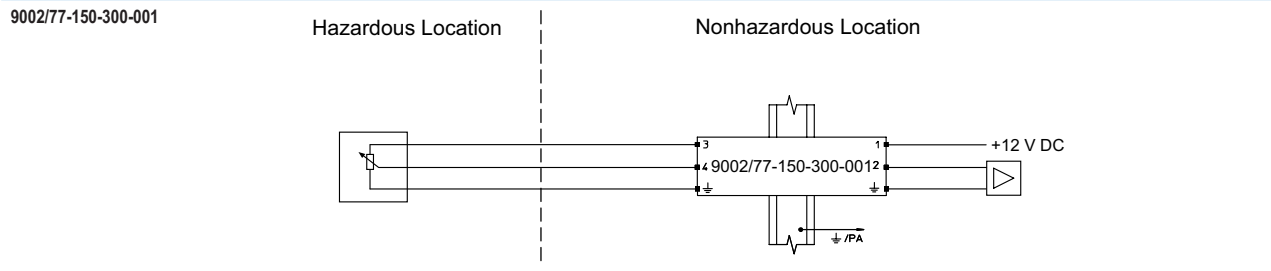

Application Note This barrier is for use with DC non inductive potentiometers with an operating voltage of +12 V.

Order Code Schematic

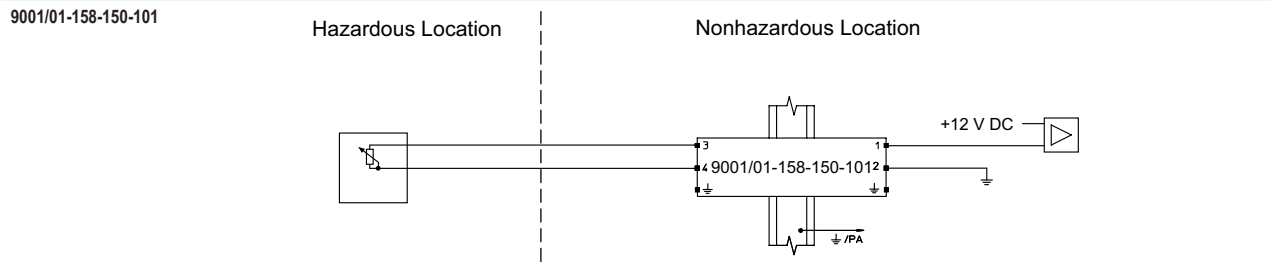

Application Note This barrier is for use with DC non inductive potentiometers with an operating voltage of +12 V and the measuring circuit in the supply line.

Displacement Sensors

Application Note It is recommended to use galvanic isolators, series 9147, instead of zener barrier for this application

Data Communication

Order Code Schematic

9002/22-240-160-001

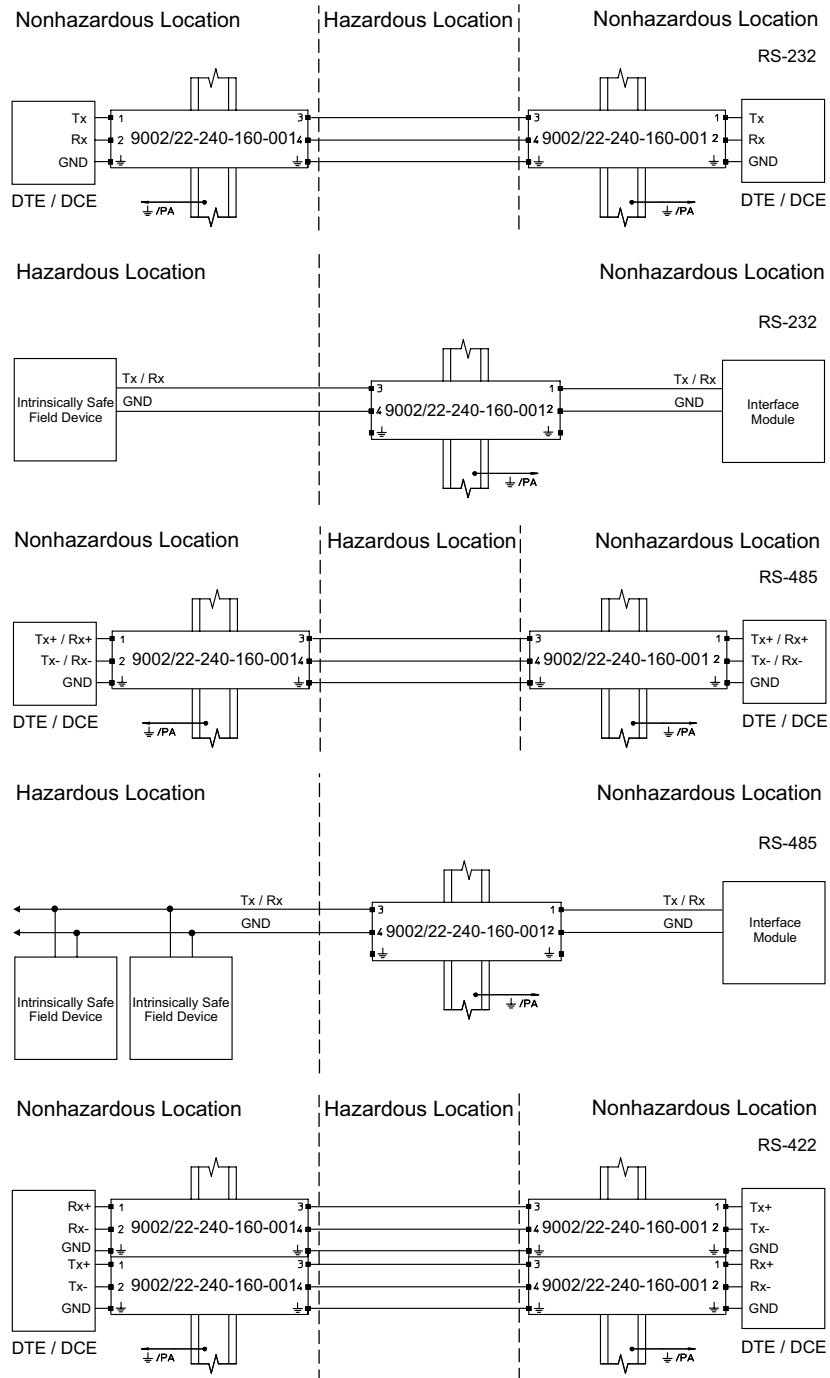

08 a

Application Note

This barrier is used for communicating with intrinsically safe field devices using serial interfaces, RS 232, RS 485, RS 422, or for taking them across a hazardous location. The barrier has been tested up to 152 kb/s with RS 232 and RS 422. In multidrop configurations with RS 485, the barrier has been tested up to 115.2 kb/s. This barrier has an operating voltage of 9 V. The safety of the above combinations must be calculated and checked for each particular application. It is recommended to test each solution to ensure functionality as the above solution will only work in certain cases.

It is recommended to use the galvanic isolator, 9185, instead of a zener barrier.

ZENER BARRIERS



Product	Series	Page	WebCode
Applications			
Zener Barriers Overview Typical Applications		231	
Dual-Channel Zener Barriers			
Dual-Channel Zener Barriers	9002	248	9002A
Dual-Channel Zener Barriers Series 9002 Diode Return Barriers Potential: Positive		263	
Dual-Channel Zener Barriers Series 9002 Potential: Alternating / Alternating		260	
Dual-Channel Zener Barriers Series 9002 Potential: Alternating / Alternating		261	
Dual-Channel Zener Barriers Series 9002 Potential: Negative / Negative		253	
Dual-Channel Zener Barriers Series 9002 Potential: Positive / Negative		254	
Dual-Channel Zener Barriers Series 9002 Potential: Positive / Positive		255	
Dual-Channel Zener Barriers Series 9002 Star Barriers / Star Barriers		251	
Dual-Channel Zener Barriers Series 9002 Zener Barriers Potential: Positive / Diode Return Barriers Potential: Positive		257	
Dual-Channel Zener Barriers Series 9002 Zener Barriers Potential: Positive / Diode Return Barriers Potential: Positive		259	
Single-Channel Zener Barriers			
Single-Channel Zener Barriers	9001	232	9001A
Single-Channel Zener Barriers Series 9001 Alternating Polarity		243	
Single-Channel Zener Barriers Series 9001 Diode Return Barriers for Positive Polarity		245	
Single-Channel Zener Barriers Series 9001 Negative Polarity		234	
Single-Channel Zener Barriers Series 9001 Positive Polarity Current Limitation		239	
Single-Channel Zener Barriers Series 9001 Positive Polarity Current Limitation + Mirror - Digital		241	
Single-Channel Zener Barriers Series 9001 Positive Polarity Passive		236	
Single-Channel Zener Barriers Series 9001 Positive Polarity Voltage Limitation		242	
Single-Channel Zener Barriers Series 9001 Zener Barriers for HART / SMART Transmitter		246	
Single-Channel Zener Barriers Series 9001 Zener Barriers for HART Transmitter		247	
Accessories and Spare Parts			
Accessories and Spare Parts Series 9001, 9002		264	

Product	Series	Page	WebCode
Dimensional Drawings			
Dimensional Drawings Series 9001, 9002		265	

For additional products and information please refer to r-stahl.com

Overview Typical Applications

	Application	INTRINSPAK Solution
Analog Input	Transmitter supply (2-wire) 4 ... 20 mA + HART	Zener Barrier 9002/13-280-093-001 9002/13-280-110-001
	Current source signals 4 ... 20 mA + HART	9002/13-280-093-001 9002/13-280-110-001
Discrete Input	Contact	9002/13-280-110-001
	PNP, NPN	9002/13-280-100-041 9002/11-280-186-001
Analog Output	I/P Converter, Control Valve Indicator	9001/01-280-110-101 9002/11-280-186-001
Discrete Output	Solenoid Valves, LEDs Horns, Beacons	9001/01-280-110-101 9002/13-252-121-041 9001/01-252-100-141 9002/11-280-186-001
Temperature Sensors	2-, 3, 4-wire RTD Potentiometers	9002/22-032-300-111 9001/02-016-150-111 9002/77-150-300-001
	Thermocouples	9002/77-093-300-001
Other Applications	Load cells *For load cell and strain gauge applications, use zener barriers.	16 V Ex. 9002/13-199-225-001 + (2) 9002/11-199-030-001 10 V Ex. 9002/11-130-360-001 + (2) 9002/11-120-024-001 ±7.5 V Ex. 9002/10-187-270-001 + 9002/10-187-020-001 + 9002/77-093-040-001
	Accelerometers, Velometers Vibration Sensors	9002/00-260-138-001
	RS485 /RS422 Profibus/Modbus	9002/22-240-160-001 (RS 232 only)

08 b



- For the intrinsically safe operation of a wide range of devices, such as HART transmitters, solenoid valves, sensors, zero-potential contacts and many more
- Compact, space-saving devices that are easy to install on a DIN rail
- Quick and efficient installation as barriers can be simultaneously snapped onto DIN rail and connected to ground (ISA - RPI12.06)
- Convenient maintenance and repair through back-up fuse feature

WebCode **9001A**



The 9001 series INTRINSPAK single-channel zener barriers enable the intrinsically safe operation of virtually all field devices. The comprehensive portfolio and the combination of zener barriers cover a wide variety of signals. The devices are incredibly robust and require little space. The back-up fuse is a convenient feature as it is standardized for all variants.

08 b

	NEC® 500 CEC Appendix J						CEC Section 18						IECEX / ATEX							
	Class I		Class II		Class III		NEC® 505 Class I			NEC® 506										
Division	1	2	1	2	1	2	Zone	0	1	2	20	21	22	Zone	0	1	2	20	21	22
Ex interface	•	•	•	•	•	•	Ex interface	•	•	•				Ex interface	•	•	•	•	•	•
Installation in		•					Installation in		•					Installation in		•				

Schematics of the zener barriers available at r-stahl.com

Technical Data	
Variant	Single-channel safety barriers Series 9001
Explosion Protection	
USA certificate FM	3011002
USA certificate UL	E81680V1S3
CAN certificate CSA	1284547
USA marking FM	Nonincendive for Class I, Div. 2, Groups A,B,C,D, T4 Class I, Zone 2, Group IIC, T4 Intrinsically safe connections for Class I,II,III, Div. 1, Groups A,B,C,D,E,F,G Class I, Zone 0, Groups IIC/IIB Hazardous location when installed per doc. 90 016 11 31 1
USA marking UL	For use in Hazardous location Class I, Div. 2, Groups A,B,C,D, T4 Providing IS circuits for Class I, Groups A,B,C,D Class II, Groups E,F,G Class III per doc. 90 016 11 31 3
CAN marking CSA	Associated equipment [Ex ia] Class I, Div. 2, Groups A,B,C,D Provides intrinsically safe circuits for Class I,II,III; or Class I, Zone 0, Groups IIC/IIB For applicable groups per installation doc. 90 016 11 31 2
IECEX gas explosion protection	Ex nA [ja Ga] IIC/IIB T4 Gc
IECEX dust explosion protection	[Ex ia Da] IIIC

Technical Data	
Variant	Single-channel safety barriers Series 9001
Explosion Protection	
Certificates	ATEX (PTB), Brazil (ULB), Canada (CSA), EAC (STV), IECEx (PTB), Korea (KGS), USA (FM), USA (UL)
Installation	in Zone 2, Class I, Div. 2, and Class I, Zone 2 and in safe area
Further information	see respective certificate and operating instructions
Electrical Data	
Resistive current limitation using frequency ≥ 50 mA	≤ 100 kHz
Resistive current limitation using frequency ≤ 50 mA	≤ 50 kHz
Leakage current I_{leak} for U_N	≤ 2 μ A
Leakage current I_{leak} for $U_N 2$	(Unless specified otherwise)
Ambient Conditions	
Ambient temperature °F	-4°F ... +140°F
Ambient temperature °C	-20 °C ... +60 °C
Storage temperature °F	-4°F ... +167°F
Storage temperature °C	-20 °C ... +75 °C
Max. relative humidity	95% on average, no condensation
Temperature influence	$\leq 0,25$ %/10K
Mechanical Data	
Degree of protection (IP)	IP40
Degree of protection note	according to IEC 60529
Terminal degree of protection (IP)	IP20
Enclosure material	Polyamide 6GF
Number of connection terminals	4
Type of connection cable	Finely stranded Solid
Conductor cross-section AWG max.	16 AWG
Connection cross section max.	1.5 mm ²
Weight	0.24 lb
Weight	0.11 kg
Mounting / Installation	
Connection type	2 PA
Cross-section ground AWG	12 AWG
Connection cross-section ground	4 mm ²
Min. torque lb / in	4.43 lb / in
Min. torque Nm	0.5 Nm
Max. torque lb / in	5.31 lb / in
Max. torque Nm	0.6 Nm
Accessories and Spare Parts see page 264	
Dimensional Drawings see page 265	

08 b

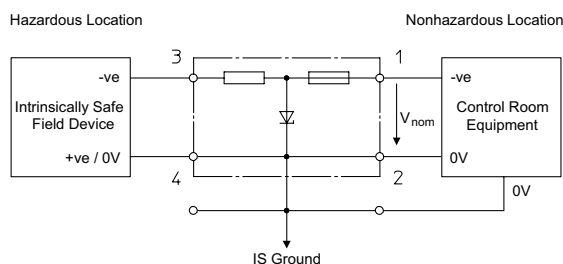

- Grounded circuit
- Allows the connection of regulated power supplies, V_{nom} , as listed in the table below
- Various safety and operational characteristics as listed in the table below
- Approved for installation in hazardous areas (refer to certificate).

FM / UL Information – Ex Interface to Class I, II, III, Division 1 or Class I, Zone 0

Product Type	Operational Characteristics				Entity Parameters			Gas Group Cable Parameters				Art. No.
	V_{nom}	R_{min}	R_{max}	I_{max}	U_0/V_{oc}	I_0/I_{sc}	P_o	L_0/L_3 for A, B, E or IIC	C_0/C_3 for A, B, E or IIC	L_0/L_3 for C, D, F, G or IIB, IIA	C_0/C_3 for C, D, F, G or IIB, IIA	
9001/00-083-442-101	6 V	24 Ω	29 Ω	110 mA	8.3 V	442 mA	917.2 mW	0.12 mH	7.2 μ F	0.5 mH	73 μ F	158333
9001/00-086-390-101	6 V	28 Ω	33 Ω	110 mA	8.6 V	390 mA	838.5 mW	0.16 mH	6.2 μ F	0.89 mH	55 μ F	158434
9001/00-280-020-101	24 V	1435 Ω	1590 Ω	15 mA	28 V	20 mA	140 mW	50 mH	0.083 μ F	50 mH	0.65 μ F	158650
9001/00-280-050-101	24 V	599 Ω	666 Ω	36 mA	28 V	50 mA	350 mW	8.5 mH	0.083 μ F	25 mH	0.65 μ F	158660
9001/00-280-085-101	24 V	340 Ω	375 Ω	64 mA	28 V	85 mA	595 mW	2.4 mH	0.083 μ F	16 mH	0.65 μ F	158344
9001/00-280-100-101	24 V	287 Ω	320 Ω	75 mA	28 V	100 mA	700 mW	1.6 mH	0.083 μ F	11 mH	0.65 μ F	158356

CSA Information – Ex Interface to Class I, II, III, Division 1

Product Type	Operational Characteristics				Entity Parameters			Gas Group Cable Parameters				Art. No.
	V_{nom}	R_{min}	R_{max}	I_{max}	U_0/V_{oc}	I_0/I_{sc}	P_o	L_0/L_3 for A, B, E	C_0/C_3 for A, B, E	L_0/L_3 for C, D, F, G	C_0/C_3 for C, D, F, G	
9001/00-083-442-101	6 V	22 Ω	29 Ω	110 mA	8.4 V	442 mA	917.2 mW	0.19 mH	6.9 μ F	0.8 mH	20.8 μ F	158333
9001/00-086-390-101	6 V	24 Ω	33 Ω	110 mA	8.6 V	377.6 mA	838.5 mW	0.16 mH	5.9 μ F	1 mH	17.6 μ F	158434
9001/00-280-020-101	24 V	1500 Ω	1590 Ω	15 mA	28 V	19.6 mA	140 mW	85 mH	0.14 μ F	306 mH	0.43 μ F	158650
9001/00-280-050-101	24 V	620 Ω	666 Ω	36 mA	28 V	47.5 mA	350 mW	15.1 mH	0.14 μ F	57 mH	0.43 μ F	158660
9001/00-280-085-101	24 V	349 Ω	375 Ω	64 mA	28.5 V	77 mA	595 mW	5 mH	0.14 μ F	19.3 mH	0.43 μ F	158344
9001/00-280-100-101	24 V	300 Ω	320 Ω	75 mA	28.5 V	100 mA	700 mW	3.6 mH	0.14 μ F	13.9 mH	0.43 μ F	158356

CSA Information – Ex Interface to Class I, Zone 0

Product Type	Operational Characteristics				Entity Parameters			Gas Group Cable Parameters				Art. No.
	V_{nom}	R_{min}	R_{max}	I_{max}	U_0/V_{oc}	I_0/I_{sc}	P_o	L_0/L_3 for IIC	C_0/C_3 for IIC	L_0/L_3 for IIA, IIB	C_0/C_3 for IIA, IIB	
9001/00-083-442-101	6 V	22 Ω	29 Ω	110 mA	8.3 V	442 mA	917.2 mW	0.12 mH	7.2 μ F	0.5 mH	73 μ F	158333
9001/00-086-390-101	6 V	24 Ω	33 Ω	110 mA	8.6 V	390 mA	838.5 mW	0.16 mH	6.2 μ F	0.89 mH	55 μ F	158434
9001/00-280-020-101	24 V	1500 Ω	1590 Ω	15 mA	28 V	20 mA	140 mW	50 mH	0.083 μ F	50 mH	0.65 μ F	158650
9001/00-280-050-101	24 V	620 Ω	666 Ω	36 mA	28 V	50 mA	350 mW	8.5 mH	0.083 μ F	25 mH	0.65 μ F	158660
9001/00-280-085-101	24 V	349 Ω	375 Ω	64 mA	28 V	85 mA	595 mW	2.4 mH	0.083 μ F	16 mH	0.65 μ F	158344
9001/00-280-100-101	24 V	300 Ω	320 Ω	75 mA	28 V	100 mA	700 mW	1.6 mH	0.083 μ F	11 mH	0.65 μ F	158356

ATEX Information – Ex Interface to Zone 0

Product Type	Operational Characteristics				Entity Parameters			Gas Group Cable Parameters				Art. No.
	V_{nom}	R_{min}	R_{max}	I_{max}	U_0/V_{oc}	I_0/I_{sc}	P_o	L_0/L_3 for IIC	C_0/C_3 for IIC	L_0/L_3 for IIB	C_0/C_3 for IIB	
9001/00-083-442-101	6 V	24 Ω	29 Ω	110 mA	8.3 V	442 mA	917.2 mW	0.1 mH	7.2 μ F	0.5 mH	73 μ F	158333
9001/00-086-390-101	6 V	28 Ω	33 Ω	110 mA	8.6 V	390 mA	839 mW	0.16 mH	6.2 μ F	0.89 mH	55 μ F	158434
9001/00-280-020-101	24 V	1435 Ω	1590 Ω	15 mA	28 V	20 mA	140 mW	50 mH	0.083 μ F	50 mH	0.65 μ F	158650

Single-Channel Zener Barriers

Series 9001
Negative Polarity



ATEX Information – Ex Interface to Zone 0												
Product Type	Operational Characteristics				Entity Parameters			Gas Group Cable Parameters				Art. No.
	V_{nom}	R_{min}	R_{max}	I_{max}	U_0/V_{oc}	I_0/I_{sc}	P_0	L_0/L_g for IIC	C_0/C_g for IIC	L_0/L_g for IIB	C_0/C_g for IIB	
9001/00-280-050-101	24 V	599 Ω	666 Ω	36 mA	28 V	50 mA	350 mW	8.5 mH	0.083 μ F	25 mH	0.65 μ F	158660
9001/00-280-085-101	24 V	340 Ω	375 Ω	64 mA	28 V	85 mA	595 mW	2.4 mH	0.083 μ F	16 mH	0.65 μ F	158344
9001/00-280-100-101	24 V	287 Ω	320 Ω	75 mA	28 V	100 mA	700 mW	1.6 mH	0.083 μ F	11 mH	0.65 μ F	158356

08 b

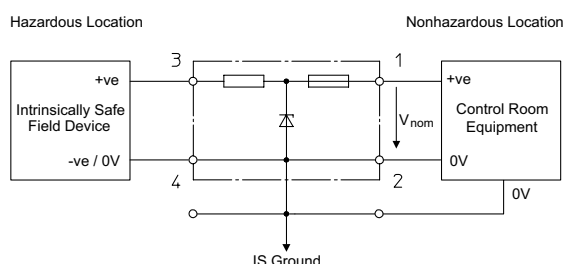

- Grounded circuit
- Allows the connection of regulated power supplies, V_{nom} , as listed in the table below
- Various safety and operational characteristics as listed in the table below
- Approved for installation in hazardous areas (refer to certificate).

Technical tips

- $T_a = 140^\circ\text{F}$ (60°C) except for 9001/01-280-165-101 in FM / UL installations where $T_a = 122^\circ\text{F}$ (50°C)
- 9001/01-280-165-101 is not allowed to interface to field devices in Gas Groups A, B, E and IIC

FM / UL Information – Ex Interface to Class I, II, III, Division 1 or Class I, Zone 0

Product Type	Operational Characteristics				Entity Parameters			Gas Group Cable Parameters				Art. No.
	V_{nom}	R_{min}	R_{max}	I_{max}	U_0/V_{oc}	I_0/I_{sc}	P_o	L_1/L_2 for A, B, E or IIC	C_1/C_2 for A, B, E or IIC	L_1/L_2 for C, D, F, G or IIB, IIA	C_1/C_2 for C, D, F, G or IIB, IIA	
9001/01-083-442-101	6 V	24 Ω	29 Ω	110 mA	8.3 V	442 mA	917.2 mW	0.12 mH	7.2 μF	0.5 mH	73 μF	158338
9001/01-086-050-101	6 V	196 Ω	218 Ω	27 mA	8.6 V	50 mA	107.5 mW	15 mH	6.2 μF	56 mH	55 μF	158379
9001/01-086-075-101	6 V	129 Ω	145 Ω	41 mA	8.6 V	75 mA	161.3 mW	6.7 mH	6.2 μF	25 mH	55 μF	158391
9001/01-086-150-101	6 V	65 Ω	73 Ω	82 mA	8.6 V	150 mA	322.5 mW	1.3 mH	6.2 μF	7 mH	55 μF	158418
9001/01-086-270-101	6 V	39 Ω	45 Ω	110 mA	8.6 V	270 mA	580.5 mW	0.23 mH	6.2 μF	2.2 mH	55 μF	158428
9001/01-086-390-101	6 V	28 Ω	33 Ω	110 mA	8.6 V	390 mA	838.5 mW	0.16 mH	6.2 μF	0.89 mH	55 μF	158439
9001/01-126-150-101	8 V	93 Ω	106 Ω	75 mA	12.6 V	150 mA	472.5 mW	1.3 mH	1.15 μF	7 mH	7.4 μF	158502
9001/01-158-150-101	12 V	120 Ω	135 Ω	88 mA	15.8 V	150 mA	592.5 mW	1.3 mH	0.478 μF	7 mH	2.88 μF	158535
9001/01-158-390-101	12 V	50 Ω	57 Ω	< 100 mA	15.8 V	390 mA	1541 mW	0.16 mH	0.478 μF	0.89 mH	2.88 μF	158509
9001/01-168-020-101	12 V	871 Ω	966 Ω	12 mA	16.8 V	20 mA	84 mW	90 mH	0.39 μF	330 mH	2.29 μF	158555
9001/01-168-075-101	12 V	235 Ω	262 Ω	45 mA	16.8 V	75 mA	315 mW	6.7 mH	0.39 μF	25 mH	2.29 μF	158568
9001/01-199-050-101	16 V	415 Ω	462 Ω	34 mA	19.9 V	50 mA	248.8 mW	15 mH	0.223 μF	56 mH	1.42 μF	158616
9001/01-199-100-101	16 V	216 Ω	241 Ω	66 mA	19.9 V	100 mA	497.5 mW	4 mH	0.223 μF	15 mH	1.42 μF	158632
9001/01-280-020-101	24 V	1435 Ω	1590 Ω	15 mA	28 V	20 mA	140 mW	50 mH	0.083 μF	50 mH	0.65 μF	158655
9001/01-280-050-101	24 V	599 Ω	666 Ω	36 mA	28 V	50 mA	350 mW	8.5 mH	0.083 μF	25 mH	0.65 μF	158665
9001/01-280-075-101	24 V	415 Ω	462 Ω	51 mA	28 V	75 mA	525 mW	3.3 mH	0.083 μF	21 mH	0.65 μF	158339
9001/01-280-085-101	24 V	340 Ω	375 Ω	64 mA	28 V	85 mA	595 mW	2.4 mH	0.083 μF	16 mH	0.65 μF	158351
9001/01-280-100-101	24 V	287 Ω	320 Ω	75 mA	28 V	100 mA	700 mW	1.6 mH	0.083 μF	11 mH	0.65 μF	158365
9001/01-280-110-101	24 V	263 Ω	294 Ω	81 mA	28 V	110 mA	770 mW	1.2 mH	0.083 μF	9 mH	0.65 μF	158380
9001/01-280-165-101	24 V	177 Ω	198 Ω	110 mA	28 V	165 mA	1155 mW			3.5 mH	0.65 μF	158392

CSA Information – Ex Interface to Class I, II, III, Division 1

Product Type	Operational Characteristics				Entity Parameters			Gas Group Cable Parameters				Art. No.
	V_{nom}	R_{min}	R_{max}	I_{max}	U_0/V_{oc}	I_0/I_{sc}	P_o	L_1/L_2 for A, B, E	C_1/C_2 for A, B, E	L_1/L_2 for C, D, F, G	C_1/C_2 for C, D, F, G	
9001/01-083-442-101	6 V	22 Ω	29 Ω	110 mA	8.4 V	442 mA	917.2 mW	0.19 mH	6.9 μF	0.8 mH	20.8 μF	158338
9001/01-086-050-101	6 V	200 Ω	218 Ω	27 mA	8.6 V	43.5 mA	107.5 mW	18 mH	5.9 μF	67.6 mH	17.6 μF	158379
9001/01-086-075-101	6 V	130 Ω	145 Ω	41 mA	8.6 V	69.7 mA	161.3 mW	7.2 mH	5.9 μF	27.5 mH	17.6 μF	158391
9001/01-086-150-101	6 V	62 Ω	73 Ω	82 mA	8.6 V	146.2 mA	322.5 mW	1.7 mH	5.9 μF	6.7 mH	17.6 μF	158418
9001/01-086-270-101	6 V	36 Ω	45 Ω	110 mA	8.6 V	251.8 mA	580.5 mW	0.26 mH	5.9 μF	2.4 mH	17.6 μF	158428
9001/01-086-390-101	6 V	24 Ω	33 Ω	110 mA	8.6 V	377.6 mA	838.5 mW	0.16 mH	5.9 μF	1 mH	17.6 μF	158439

Single-Channel Zener Barriers

Series 9001
Positive Polarity Passive



CSA Information – Ex Interface to Class I, II, III, Division 1												
Product Type	Operational Characteristics				Entity Parameters			Gas Group Cable Parameters				Art. No.
	V _{nom}	R _{min}	R _{max}	I _{max}	U ₀ /V _{oc}	I ₀ /I _{sc}	P ₀	L ₀ /L _c for A, B, E	C ₀ /C _c for A, B, E	L ₀ /L _c for C, D, F, G	C ₀ /C _c for C, D, F, G	
9001/01-126-150-101	8 V	91 Ω	106 Ω	75 mA	12.6 V	145.7 mA	472.5 mW	1.3 mH	1.4 μF	6.8 mH	4.1 μF	158502
9001/01-158-150-101	12 V	120 Ω	135 Ω	88 mA	15.7 V	138.2 mA	592.5 mW	1.6 mH	0.67 μF	7.5 mH	2 μF	158535
9001/01-158-390-101	12 V	43 Ω	57 Ω	< 100 mA	15.7 V	386.8 mA	1541 mW	0.15 mH	0.67 μF	0.9 mH	2 μF	158509
9001/01-168-020-101	12 V	909 Ω	966 Ω	12 mA	16.8 V	18.7 mA	84 mW	93.9 mH	0.55 μF	337 mH	1.7 μF	158555
9001/01-168-075-101	12 V	240 Ω	262 Ω	45 mA	16.8 V	73.7 mA	315 mW	6.4 mH	0.55 μF	24.8 mH	1.7 μF	158568
9001/01-199-050-101	16 V	430 Ω	462 Ω	34 mA	19.9 V	48.7 mA	248.8 mW	14.4 mH	0.34 μF	54.4 mH	1 μF	158616
9001/01-199-100-101	16 V	220 Ω	241 Ω	66 mA	19.9 V	95.2 mA	497.5 mW	3.9 mH	0.34 μF	15.2 mH	1 μF	158632
9001/01-280-020-101	24 V	1500 Ω	1590 Ω	15 mA	28 V	19.6 mA	140 mW	85 mH	0.14 μF	306 mH	0.43 μF	158655
9001/01-280-050-101	24 V	620 Ω	666 Ω	36 mA	28 V	47.5 mA	350 mW	15.1 mH	0.14 μF	57 mH	0.43 μF	158665
9001/01-280-075-101	24 V	430 Ω	462 Ω	51 mA	28 V	68.5 mA	525 mW	7.4 mH	0.14 μF	28.4 mH	0.43 μF	158339
9001/01-280-085-101	24 V	349 Ω	375 Ω	64 mA	28.5 V	77 mA	595 mW	5 mH	0.14 μF	19.3 mH	0.43 μF	158351
9001/01-280-100-101	24 V	300 Ω	320 Ω	75 mA	28.5 V	100 mA	700 mW	3.6 mH	0.14 μF	13.9 mH	0.43 μF	158365
9001/01-280-110-101	24 V	270 Ω	294 Ω	81 mA	28.5 V	111 mA	770 mW	3.6 mH	0.14 μF	11.7 mH	0.43 μF	158380
9001/01-280-165-101	24 V	180 Ω	198 Ω	110 mA	28.5 V	163.7 mA	1155 mW	-	-	5.4 mH	0.43 μF	158392

08 b

CSA Information – Ex Interface to Class I, Zone 0												
Product Type	Operational Characteristics				Entity Parameters			Gas Group Cable Parameters				Art. No.
	V _{nom}	R _{min}	R _{max}	I _{max}	U ₀ /V _{oc}	I ₀ /I _{sc}	P ₀	L ₀ /L _c for IIC	C ₀ /C _c for IIC	L ₀ /L _c for IIA, IIB	C ₀ /C _c for IIA, IIB	
9001/01-083-442-101	6 V	22 Ω	29 Ω	110 mA	8.3 V	442 mA	917.2 mW	0.12 mH	7.2 μF	0.5 mH	73 μF	158338
9001/01-086-050-101	6 V	200 Ω	218 Ω	27 mA	8.6 V	50 mA	107.5 mW	15 mH	6.2 μF	56 mH	55 μF	158379
9001/01-086-075-101	6 V	130 Ω	145 Ω	41 mA	8.6 V	75 mA	161.3 mW	6.7 mH	6.2 μF	25 mH	55 μF	158391
9001/01-086-150-101	6 V	62 Ω	73 Ω	82 mA	8.6 V	150 mA	322.5 mW	1.3 mH	6.2 μF	7 mH	55 μF	158418
9001/01-086-270-101	6 V	36 Ω	45 Ω	110 mA	8.6 V	270 mA	580.5 mW	0.23 mH	6.2 μF	2.2 mH	55 μF	158428
9001/01-086-390-101	6 V	24 Ω	33 Ω	110 mA	8.6 V	390 mA	838.5 mW	0.16 mH	6.2 μF	0.89 mH	55 μF	158439
9001/01-126-150-101	8 V	91 Ω	106 Ω	75 mA	12.6 V	150 mA	472.5 mW	1.3 mH	1.15 μF	7 mH	7.4 μF	158502
9001/01-158-150-101	12 V	120 Ω	135 Ω	88 mA	15.8 V	150 mA	592.5 mW	1.3 mH	0.478 μF	7 mH	2.88 μF	158535
9001/01-158-390-101	12 V	43 Ω	57 Ω	< 100 mA	15.8 V	390 mA	1541 mW	0.16 mH	0.478 μF	0.89 mH	2.88 μF	158509
9001/01-168-020-101	12 V	909 Ω	966 Ω	12 mA	16.8 V	20 mA	84 mW	90 mH	0.39 μF	330 mH	2.29 μF	158555
9001/01-168-075-101	12 V	240 Ω	262 Ω	45 mA	16.8 V	75 mA	315 mW	6.7 mH	0.39 μF	25 mH	2.29 μF	158568
9001/01-199-050-101	16 V	430 Ω	462 Ω	34 mA	19.9 V	50 mA	248.8 mW	15 mH	0.223 μF	56 mH	1.42 μF	158616
9001/01-199-100-101	16 V	220 Ω	241 Ω	66 mA	19.9 V	100 mA	497.5 mW	4 mH	0.223 μF	15 mH	1.42 μF	158632
9001/01-280-020-101	24 V	1500 Ω	1590 Ω	15 mA	28 V	20 mA	140 mW	50 mH	0.083 μF	50 mH	0.65 μF	158655
9001/01-280-050-101	24 V	620 Ω	666 Ω	36 mA	28 V	50 mA	350 mW	8.5 mH	0.083 μF	25 mH	0.65 μF	158665
9001/01-280-075-101	24 V	430 Ω	462 Ω	51 mA	28 V	75 mA	525 mW	3.3 mH	0.083 μF	21 mH	0.65 μF	158339
9001/01-280-085-101	24 V	349 Ω	375 Ω	64 mA	28 V	85 mA	595 mW	2.4 mH	0.083 μF	16 mH	0.65 μF	158351
9001/01-280-100-101	24 V	300 Ω	320 Ω	75 mA	28 V	100 mA	700 mW	1.6 mH	0.083 μF	11 mH	0.65 μF	158365
9001/01-280-110-101	24 V	270 Ω	294 Ω	81 mA	28 V	110 mA	770 mW	1.2 mH	0.083 μF	9 mH	0.65 μF	158380
9001/01-280-165-101	24 V	180 Ω	198 Ω	110 mA	28 V	165 mA	1155 mW	-	-	3.5 mH	0.65 μF	158392

ATEX Information – Ex Interface to Zone 0

Product Type	Operational Characteristics				Entity Parameters			Gas Group Cable Parameters				Art. No.
	V_{nom}	R_{min}	R_{max}	I_{max}	U_0/V_{oc}	I_0/I_{sc}	P_0	L_0/L_g for IIC	C_0/C_g for IIC	L_0/L_g for IIB	C_0/C_g for IIB	
9001/01-083-442-101	6 V	24 Ω	29 Ω	110 mA	8.3 V	442 mA	917.2 mW	0.1 mH	7.2 μF	0.5 mH	73 μF	158338
9001/01-086-050-101	6 V	196 Ω	218 Ω	27 mA	8.6 V	50 mA	107.5 mW	15 mH	6.2 μF	56 mH	55 μF	158379
9001/01-086-075-101	6 V	129 Ω	145 Ω	41 mA	8.6 V	75 mA	161.3 mW	6.6 mH	6.2 μF	25 mH	55 μF	158391
9001/01-086-150-101	6 V	65 Ω	73 Ω	82 mA	8.6 V	150 mA	322.5 mW	1.3 mH	6.2 μF	7 mH	55 μF	158418
9001/01-086-270-101	6 V	39 Ω	45 Ω	110 mA	8.6 V	270 mA	580.5 mW	0.23 mH	6.2 μF	2.2 mH	55 μF	158428
9001/01-086-390-101	6 V	28 Ω	33 Ω	110 mA	8.6 V	390 mA	839 mW	0.16 mH	6.2 μF	1 mH	55 μF	158439
9001/01-126-150-101	8 V	93 Ω	106 Ω	75 mA	12.6 V	150 mA	473 mW	1.3 mH	1.15 μF	7 mH	7.4 μF	158502
9001/01-158-150-101	12 V	120 Ω	135 Ω	88 mA	15.8 V	150 mA	593 mW	1 mH	0.478 μF	7 mH	2.88 μF	158535
9001/01-158-390-101	12 V	50 Ω	57 Ω	< 100 mA	15.8 V	390 mA	1541 mW	0.16 mH	0.478 μF	0.89 mH	2.88 μF	158509
9001/01-168-020-101	12 V	871 Ω	966 Ω	12 mA	16.8 V	20 mA	84 mW	90 mH	0.39 μF	330 mH	2.29 μF	158555
9001/01-168-075-101	12 V	235 Ω	262 Ω	45 mA	16.8 V	75 mA	315 mW	6.6 mH	0.39 μF	25 mH	2.29 μF	158568
9001/01-199-050-101	16 V	415 Ω	462 Ω	34 mA	19.9 V	50 mA	249 mW	15 mH	0.223 μF	56 mH	1.42 μF	158616
9001/01-199-100-101	16 V	216 Ω	241 Ω	66 mA	19.9 V	100 mA	498 mW	4 mH	0.223 μF	15 mH	1.42 μF	158632
9001/01-280-020-101	24 V	1435 Ω	1590 Ω	15 mA	28 V	20 mA	140 mW	50 mH	0.083 μF	50 mH	0.65 μF	158655
9001/01-280-050-101	24 V	599 Ω	666 Ω	36 mA	28 V	50 mA	350 mW	8.5 mH	0.083 μF	25 mH	0.65 μF	158665
9001/01-280-075-101	24 V	415 Ω	462 Ω	51 mA	28 V	75 mA	525 mW	3.3 mH	0.083 μF	21 mH	0.65 μF	158339
9001/01-280-085-101	24 V	340 Ω	375 Ω	64 mA	28 V	85 mA	595 mW	2.4 mH	0.083 μF	16 mH	0.65 μF	158351
9001/01-280-100-101	24 V	287 Ω	320 Ω	75 mA	28 V	100 mA	700 mW	1.6 mH	0.083 μF	11 mH	0.65 μF	158365
9001/01-280-110-101	24 V	263 Ω	294 Ω	81 mA	28 V	110 mA	770 mW	1.2 mH	0.083 μF	9 mH	0.65 μF	158380
9001/01-280-165-101	24 V	177 Ω	198 Ω	110 mA	28 V	165 mA	1155 mW			3.5 mH	0.65 μF	158392

08 b

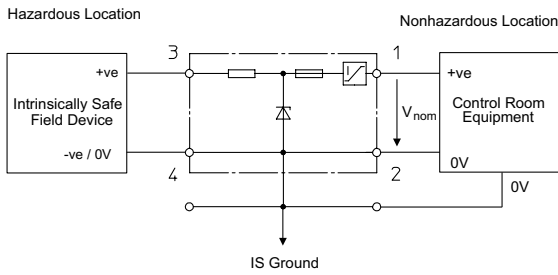

- Grounded circuit
- Current limitation to < 100 mA
- Various safety and operational characteristics as listed in the table below
- Approved for installation in hazardous areas (refer to certificate).

Technical tips

- 9001/01-199-390-101 and 9001/01-280-280-101 are not allowed for interfacing to field devices in Gas Groups A, B, E and IIC
- $T_a = 140\text{ }^\circ\text{F}$ ($60\text{ }^\circ\text{C}$) except for 9001/01-280-280-101 in FM / UL / ATEX installations where $T_a = 122\text{ }^\circ\text{F}$ ($50\text{ }^\circ\text{C}$)

FM / UL Information – Ex Interface to Class I, II, III, Division 1 or Class I, Zone 0												
Product Type	Operational Characteristics				Entity Parameters			Gas Group Cable Parameters				Art. No.
	V_{nom}	R_{min}	R_{max}	I_{max}	U_0/V_{oc}	I_0/I_{sc}	P_o	L_f/L_g for A, B, E or IIC	C_f/C_g for A, B, E or IIC	L_f/L_g for C, D, F, G or IIB, IIA	C_f/C_g for C, D, F, G or IIB, IIA	
9001/01-158-270-101	12 V	69 Ω	78 Ω	< 100 mA	15.8 V	270 mA	1067 mW	0.23 mH	0.478 μF	2.2 mH	2.88 μF	158503
9001/01-158-390-101	12 V	50 Ω	57 Ω	< 100 mA	15.8 V	390 mA	1541 mW	0.16 mH	0.478 μF	0.89 mH	2.88 μF	158509
9001/01-199-390-101	16 V	62 Ω	71 Ω	< 100 mA	19.9 V	390 mA	1940 mW	-	-	0.89 mH	1.42 μF	158519
9001/01-280-280-101	24 V	115 Ω	128 Ω	< 100 mA	28 V	280 mA	1960 mW	-	-	0.6 mH	0.65 μF	158722

08 b

CSA Information – Ex Interface to Class I, II, III, Division 1												
Product Type	Operational Characteristics				Entity Parameters			Gas Group Cable Parameters				Art. No.
	V_{nom}	R_{min}	R_{max}	I_{max}	U_0/V_{oc}	I_0/I_{sc}	P_o	L_f/L_g for A, B, E	C_f/C_g for A, B, E	L_f/L_g for C, D, F, G	C_f/C_g for C, D, F, G	
9001/01-158-270-101	12 V	62 Ω	78 Ω	< 100 mA	15.7 V	267.1 mA	1067 mW	0.23 mH	0.67 μF	2.1 mH	2 μF	158503
9001/01-158-390-101	12 V	43 Ω	57 Ω	< 100 mA	15.7 V	386.8 mA	1541 mW	0.15 mH	0.67 μF	0.9 mH	2 μF	158509
9001/01-199-390-101	16 V	54.5 Ω	71 Ω	< 100 mA	19.8 V	382.7 mA	1940 mW	-	-	0.9 mH	1.03 μF	158519
9001/01-280-280-101	24 V	110 Ω	128 Ω	< 100 mA	28.5 V	267.8 mA	1960 mW	-	-	2.1 mH	0.43 μF	158722

CSA Information – Ex Interface to Class I, Zone 0												
Product Type	Operational Characteristics				Entity Parameters			Gas Group Cable Parameters				Art. No.
	V_{nom}	R_{min}	R_{max}	I_{max}	U_0/V_{oc}	I_0/I_{sc}	P_o	L_f/L_g for IIC	C_f/C_g for IIC	L_f/L_g for IIA, IIB	C_f/C_g for IIA, IIB	
9001/01-158-270-101	12 V	62 Ω	78 Ω	< 100 mA	15.8 V	270 mA	1067 mW	0.23 mH	0.478 μF	2.2 mH	2.88 μF	158503
9001/01-158-390-101	12 V	43 Ω	57 Ω	< 100 mA	15.8 V	390 mA	1541 mW	0.16 mH	0.478 μF	0.89 mH	2.88 μF	158509
9001/01-199-390-101	16 V	54.5 Ω	71 Ω	< 100 mA	19.9 V	390 mA	1940 mW	-	-	0.89 mH	1.42 μF	158519
9001/01-280-280-101	24 V	110 Ω	128 Ω	< 100 mA	28 V	280 mA	1960 mW	-	-	0.6 mH	0.65 μF	158722

ATEX Information – Ex Interface to Zone 0												
Product Type	Operational Characteristics				Entity Parameters			Gas Group Cable Parameters				Art. No.
	V_{nom}	R_{min}	R_{max}	I_{max}	U_0/V_{oc}	I_0/I_{sc}	P_0	L_0/L_g for IIC	C_0/C_g for IIC	L_0/L_g for IIB	C_0/C_g for IIB	
9001/01-158-270-101	12 V	69 Ω	78 Ω	< 100 mA	15.8 V	270 mA	1067 mW	0.23 mH	0.478 μ F	2.2 mH	2.88 μ F	158503
9001/01-158-390-101	12 V	50 Ω	57 Ω	< 100 mA	15.8 V	390 mA	1541 mW	0.16 mH	0.478 μ F	0.89 mH	2.88 μ F	158509
9001/01-199-390-101	16 V	62 Ω	71 Ω	< 100 mA	19.9 V	390 mA	1940 mW			0.89 mH	1.42 μ F	158519
9001/01-280-280-101	24 V	115 Ω	128 Ω	< 100 mA	28 V	280 mA	1960 mW			0.6 mH	0.65 μ F	158722

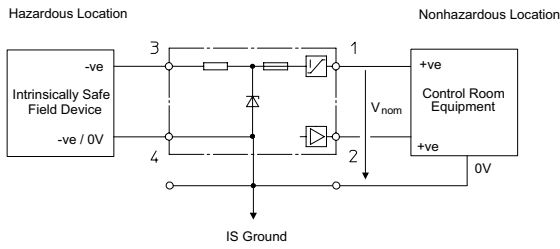

- Application specific for the connection of volt free contacts
- Operational current limited to < 40 mA
- Grounded field device
- Input to control system elevated above 0 V
- Allows the connection of unregulated power supplies, V_{nom} between +20 to 35 V DC
- Approved for installation in hazardous areas (refer to certificate).

Technical tips

- As terminal 4 is connected to ground, this barrier should not be used for fail safe applications. Use the 9002/13-252-121-041 instead.
- Maximum leakage current (terminal 1 to ground (0 V)) < 100 μ A

FM / UL Information – Ex Interface to Class I, II, III, Division 1 or Class I, Zone 0

Product Type	Operational Characteristics				Entity Parameters			Gas Group Cable Parameters				Art. No.
	V_{nom}	R_{min}	R_{max}	I_{max}	U_0/V_{oc}	I_0/I_{sc}	P_o	L_0/L_a for A, B, E of IIC	C_0/C_s for A, B, E or IIC	L_0/L_a for C, D, F, G or IIB, IIA	C_0/C_s for C, D, F, G or IIB, IIA	
9001/01-252-060-141	20 ... 35 V	455 Ω	506 Ω	40 mA	25.2 V	60 mA	378 mW	6.2 mH	0.107 μ F	25 mH	0.82 μ F	158693

08 b

CSA Information – Ex Interface to Class I, II, III, Division 1

Product Type	Operational Characteristics				Entity Parameters			Gas Group Cable Parameters				Art. No.
	V_{nom}	R_{min}	R_{max}	I_{max}	U_0/V_{oc}	I_0/I_{sc}	P_o	L_0/L_a for A, B, E	C_0/C_s for A, B, E	L_0/L_a for C, D, F, G	C_0/C_s for C, D, F, G	
9001/01-252-060-141	20 ... 35 V	470 Ω	506 Ω	40 mA	25.2 V	56.4 mA	378 mW	10.8 mH	0.18 μ F	41.1 mH	0.55 μ F	158693

CSA Information – Ex Interface to Class I, Zone 0

Product Type	Operational Characteristics				Entity Parameters			Gas Group Cable Parameters				Art. No.
	V_{nom}	R_{min}	R_{max}	I_{max}	U_0/V_{oc}	I_0/I_{sc}	P_o	L_0/L_a for IIC	C_0/C_s for IIC	L_0/L_a for IIA, IIB	C_0/C_s for IIA, IIB	
9001/01-252-060-141	20 ... 35 V	470 Ω	506 Ω	40 mA	25.2 V	60 mA	378 mW	6.2 mH	0.107 μ F	25 mH	0.82 μ F	158693

ATEX Information – Ex Interface to Zone 0

Product Type	Operational Characteristics				Entity Parameters			Gas Group Cable Parameters				Art. No.
	V_{nom}	R_{min}	R_{max}	I_{max}	U_0/V_{oc}	I_0/I_{sc}	P_o	L_0/L_a for IIC	C_0/C_s for IIC	L_0/L_a for IIB	C_0/C_s for IIB	
9001/01-252-060-141	20 ... 35 V	455 Ω	506 Ω	40 mA	25.2 V	60 mA	378 mW	6.2 mH	0.107 μ F	25 mH	0.82 μ F	158693

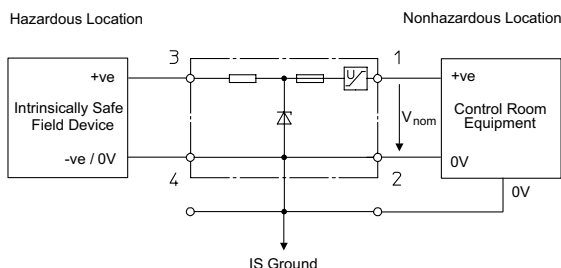

- Application specific for the connection of solenoid valves, LEDs or audible alarms
- Grounded circuit
- Allows the connection of unregulated power supplies, V_{nom} between +20 to 35 V DC
- Approved for installation in hazardous areas (refer to certificate).

Technical tips

- Maximum leakage current at 24 V (terminal 1 to ground (0 V)) = 1 mA
- Maximum leakage current at 35 V (terminal 1 to ground (0 V)) = 10 mA

FM / UL Information – Ex Interface to Class I, II, III, Division 1 or Class I, Zone 0

Product Type	Operational Characteristics				Entity Parameters			Gas Group Cable Parameters				Art. No.
	V_{nom}	R_{min}	R_{max}	I_{max}	U_o/V_{oc}	I_o/I_{sc}	P_o	L_o/L_s for A, B, E or IIC	C_o/C_s for A, B, E or IIC	L_o/L_s for C, D, F, G or IIB, IIA	C_o/C_s for C, D, F, G or IIB, IIA	
9001/01-252-100-141	20 ... 35 V	259 Ω	268 Ω	78 mA	25.2 V	100 mA	630 mW	2 mH	0.107 μF	11 mH	0.82 μF	158697

CSA Information – Ex Interface to Class I, II, III, Division 1

Product Type	Operational Characteristics				Entity Parameters			Gas Group Cable Parameters				Art. No.
	V_{nom}	R_{min}	R_{max}	I_{max}	U_o/V_{oc}	I_o/I_{sc}	P_o	L_o/L_s for A, B, E	C_o/C_s for A, B, E	L_o/L_s for C, D, F, G	C_o/C_s for C, D, F, G	
9001/01-252-100-141	20 ... 35 V	255 Ω	268 Ω	78 mA	25.2 V	100 mA	630 mW	3.5 mH	0.18 μF	13.9 mH	0.55 μF	158697

CSA Information – Ex Interface to Class I, Zone 0

Product Type	Operational Characteristics				Entity Parameters			Gas Group Cable Parameters				Art. No.
	V_{nom}	R_{min}	R_{max}	I_{max}	U_o/V_{oc}	I_o/I_{sc}	P_o	L_o/L_s for IIC	C_o/C_s for IIC	L_o/L_s for IIA, IIB	C_o/C_s for IIA, IIB	
9001/01-252-100-141	20 ... 35 V	255 Ω	268 Ω	78 mA	25.2 V	100 mA	630 mW	2 mH	0.107 μF	11 mH	0.82 μF	158697

ATEX Information – Ex Interface to Zone 0

Product Type	Operational Characteristics				Entity Parameters			Gas Group Cable Parameters				Art. No.
	V_{nom}	R_{min}	R_{max}	I_{max}	U_o/V_{oc}	I_o/I_{sc}	P_o	L_o/L_s for IIC	C_o/C_s for IIC	L_o/L_s for IIB	C_o/C_s for IIB	
9001/01-252-100-141	20 ... 35 V	259 Ω	268 Ω	78 mA	25.2 V	100 mA	630 mW	2 mH	0.107 μF	11 mH	0.82 μF	158697

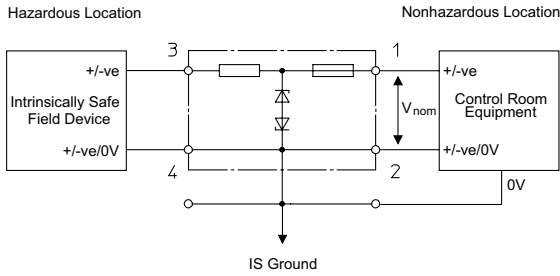

- Grounded circuit
- Suitable for AC and DC circuits
- Various safety and operational characteristics as listed in the table below
- Approved for installation in hazardous areas (refer to certificate).

Technical tips

- 9001/02-412-095-101 not allowed for interfacing to field devices in Gas Groups A, B, E and IIC
- 9001/02-016-...-1.1 - Maximum leakage current (terminal 1 to ground (0V)) < 10 µA
- 9001/02-016-...-111 - Tolerance = +0.5 %

FM / UL Information – Ex Interface to Class I, II, III, Division 1 or Class I, Zone 0												
Product Type	Operational Characteristics				Entity Parameters			Gas Group Cable Parameters				Art. No.
	V _{nom}	R _{min}	R _{max}	I _{max}	U ₀ /V _{oc}	I ₀ /I _{sc}	P ₀	L ₀ /L _g for A, B, E or IIC	C ₀ /C _g for A, B, E or IIC	L ₀ /L _g for C, D, F, G or IIB, IIA	C ₀ /C _g for C, D, F, G or IIB, IIA	
9001/02-016-015-101	± 0.7 V	120 Ω	134 Ω	5 mA	1.6 V	15 mA	6 mW	160 mH	100 µF	560 mH	1000 µF	158669
9001/02-016-050-111	± 0.7 V	37 Ω	40 Ω	17 mA	1.6 V	50 mA	20 mW	15 mH	100 µF	56 mH	1000 µF	158677
9001/02-016-150-111	± 0.7 V	19.9 Ω	20.1 Ω	35 mA	1.6 V	150 mA	60 mW	1.3 mH	100 µF	7 mH	1000 µF	158685
9001/02-016-320-101	± 0.7 V	11 Ω	14 Ω	50 mA	1.6 V	320 mA	128 mW	0.19 mH	100 µF	1.6 mH	1000 µF	158497
9001/02-093-003-101	± 6 V	3141 Ω	3473 Ω	1.7 mA	9.3 V	3 mA	6.975 mW	1000 mH	4.1 µF	1000 mH	31 µF	158741
9001/02-093-030-101	± 6 V	319 Ω	355 Ω	16 mA	9.3 V	30 mA	69.75 mW	40 mH	4.1 µF	150 mH	31 µF	158743
9001/02-093-390-101	± 6 V	31 Ω	36 Ω	110 mA	9.3 V	390 mA	906.8 mW	0.16 mH	4.1 µF	0.89 mH	31 µF	158755
9001/02-133-150-101	± 10 V	102 Ω	115 Ω	86 mA	13.3 V	150 mA	498.8 mW	1.3 mH	0.91 µF	7 mH	5.6 µF	158758
9001/02-175-100-101	± 12 V	198 Ω	223 Ω	53 mA	17.5 V	100 mA	437.5 mW	4 mH	0.339 µF	15 mH	1.97 µF	158301
9001/02-280-090-101	± 24 V	320 Ω	357 Ω	67 mA	28 V	90 mA	630 mW	2.2 mH	0.083 µF	14 mH	0.65 µF	158317
9001/02-412-095-101	± 36 V	456 Ω	508 Ω	70 mA	41.2 V	95 mA	978.5 mW			9 mH	0.287 µF	158329

08 b

CSA Information – Ex Interface to Class I, II, III, Division 1												
Product Type	Operational Characteristics				Entity Parameters			Gas Group Cable Parameters				Art. No.
	V _{nom}	R _{min}	R _{max}	I _{max}	U ₀ /V _{oc}	I ₀ /I _{sc}	P ₀	L ₀ /L _g for A, B, E	C ₀ /C _g for A, B, E	L ₀ /L _g for C, D, F, G	C ₀ /C _g for C, D, F, G	
9001/02-016-015-101	± 0.7 V	121 Ω	134 Ω	5 mA	1.6 V	17 mA	6 mW	172 mH	1000 µF	608 mH	3000 µF	158669
9001/02-016-050-111	± 0.7 V	33.2 Ω	40 Ω	17 mA	1.64 V	49.9 mA	20 mW	13.8 mH	1000 µF	52 mH	3000 µF	158677
9001/02-016-150-111	± 0.7 V	13 Ω	20.1 Ω	35 mA	1.6 V	155 mA	60 mW	2.2 mH	1000 µF	8.7 mH	3000 µF	158685
9001/02-016-320-101	± 0.7 V	5.6 Ω	14 Ω	50 mA	1.6 V	376 mA	128 mW	0.19 mH	1000 µF	1.6 mH	3000 µF	158497
9001/02-093-003-101	± 6 V	3320 Ω	3473 Ω	1.7 mA	9.4 V	3 mA	6.975 mW	1000 mH	3.7 µF	1000 mH	11.2 µF	158741
9001/02-093-030-101	± 6 V	332 Ω	355 Ω	16 mA	9.4 V	29 mA	69.75 mW	39.1 mH	3.7 µF	143 mH	11.2 µF	158743
9001/02-093-390-101	± 6 V	27 Ω	36 Ω	110 mA	9.4 V	374 mA	906.8 mW	0.16 mH	3.7 µF	1 mH	11.2 µF	158755
9001/02-133-150-101	± 10 V	100 Ω	115 Ω	86 mA	13.4 V	143 mA	498.8 mW	1.3 mH	1.1 µF	7 mH	3.2 µF	158758
9001/02-175-100-101	± 12 V	200 Ω	223 Ω	53 mA	17.6 V	94 mA	437.5 mW	4 mH	0.47 µF	15.7 mH	1.4 µF	158301
9001/02-280-090-101	± 24 V	330 Ω	357 Ω	67 mA	27.9 V	90 mA	630 mW	4.3 mH	0.14 µF	16.9 mH	0.42 µF	158317
9001/02-412-095-101	± 36 V	470 Ω	508 Ω	70 mA	41.4 V	93.6 mA	978.5 mW	-	-	15.7 mH	0.18 µF	158329

CSA Information – Ex Interface to Class I, Zone 0

Product Type	Operational Characteristics				Entropy Parameters			Gas Group Cable Parameters				Art. No.
	V _{nom}	R _{min}	R _{max}	I _{max}	U ₀ /V _{oc}	I ₀ /I _{sc}	P ₀	L ₀ /L _s for IIC	C ₀ /C _s for IIC	L ₀ /L _s for IIA, IIB	C ₀ /C _s for IIA, IIB	
9001/02-016-015-101	± 0.7 V	121 Ω	134 Ω	5 mA	1.6 V	15 mA	6 mW	160 mH	100 µF	560 mH	1000 µF	158669
9001/02-016-050-111	± 0.7 V	33.2 Ω	40 Ω	17 mA	1.6 V	50 mA	20 mW	15 mH	100 µF	56 mH	1000 µF	158677
9001/02-016-150-111	± 0.7 V	13 Ω	20.1 Ω	35 mA	1.6 V	150 mA	60 mW	1.3 mH	100 µF	7 mH	1000 µF	158685
9001/02-016-320-101	± 0.7 V	5.6 Ω	14 Ω	50 mA	1.6 V	320 mA	128 mW	0.19 mH	100 µF	1.6 mH	1000 µF	158497
9001/02-093-003-101	± 6 V	3320 Ω	3473 Ω	1,7 mA	9.3 V	3 mA	6.975 mW	1000 mH	4.1 µF	1000 mH	31 µF	158741
9001/02-093-030-101	± 6 V	332 Ω	355 Ω	16 mA	9.3 V	30 mA	69.75 mW	40 mH	4.1 µF	150 mH	31 µF	158743
9001/02-093-390-101	± 6 V	27 Ω	36 Ω	110 mA	9.3 V	390 mA	906.8 mW	0.16 mH	4.1 µF	0.89 mH	31 µF	158755
9001/02-133-150-101	± 10 V	100 Ω	115 Ω	86 mA	13.3 V	150 mA	498.8 mW	1.3 mH	0.91 µF	7 mH	5.6 µF	158758
9001/02-175-100-101	± 12 V	200 Ω	223 Ω	53 mA	17.5 V	100 mA	437.5 mW	4 mH	0.339 µF	15 mH	1.97 µF	158301
9001/02-280-090-101	± 24 V	330 Ω	357 Ω	67 mA	28 V	90 mA	630 mW	2.2 mH	0.083 µF	14 mH	0.65 µF	158317
9001/02-412-095-101	± 36 V	470 Ω	508 Ω	70 mA	41.2 V	95 mA	978.5 mW	-	-	9 mH	0.287 µF	158329

ATEX Information – Ex Interface to Zone 0

Product Type	Operational Characteristics				Entropy Parameters			Gas Group Cable Parameters				Art. No.
	V _{nom}	R _{min}	R _{max}	I _{max}	U ₀ /V _{oc}	I ₀ /I _{sc}	P ₀	L ₀ /L _s for IIC	C ₀ /C _s for IIC	L ₀ /L _s for IIB	C ₀ /C _s for IIB	
9001/02-016-015-101	± 0.7 V	120 Ω	134 Ω	5 mA	1.6 V	15 mA	6 mW	160 mH	100 µF	560 mH	1000 µF	158669
9001/02-016-050-111	± 0.7 V	37 Ω	40 Ω	17 mA	1.6 V	50 mA	20 mW	15 mH	100 µF	56 mH	1000 µF	158677
9001/02-016-150-111	± 0.7 V	19.9 Ω	20.1 Ω	35 mA	1.6 V	150 mA	60 mW	1.3 mH	100 µF	7 mH	1000 µF	158685
9001/02-016-320-101	± 0.7 V	11 Ω	14 Ω	50 mA	1.6 V	320 mA	128 mW	0.19 mH	100 µF	1.6 mH	1000 µF	158497
9001/02-093-003-101	± 6 V	3141 Ω	3473 Ω	1,7 mA	9.3 V	3 mA	6.975 mW	1000 mH	4.1 µF	1000 mH	31 µF	158741
9001/02-093-030-101	± 6 V	319 Ω	355 Ω	16 mA	9.3 V	30 mA	69.8 mW	40 mH	4.1 µF	150 mH	31 µF	158743
9001/02-093-390-101	± 6 V	31 Ω	36 Ω	110 mA	9.3 V	390 mA	906.8 mW	0.16 mH	4.1 µF	0.89 mH	31 µF	158755
9001/02-133-150-101	± 10 V	102 Ω	115 Ω	86 mA	13.3 V	150 mA	498.8 mW	1.3 mH	0.91 µF	7 mH	5.6 µF	158758
9001/02-175-100-101	± 12 V	198 Ω	223 Ω	53 mA	17.5 V	100 mA	437.5 mW	4 mH	0.339 µF	15 mH	1.97 µF	158301
9001/02-280-090-101	± 24 V	320 Ω	357 Ω	67 mA	28 V	90 mA	630 mW	2.2 mH	0.083 µF	14 mH	0.65 µF	158317
9001/02-412-095-101	± 36 V	456 Ω	508 Ω	70 mA	41.2 V	95 mA	979 mW			9 mH	0.287 µF	158329

08 b

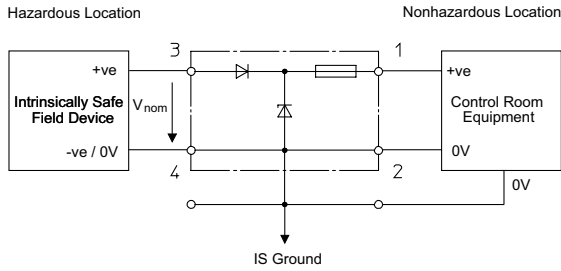

- Grounded circuit
- For DC current signal returns
- Current limitation to $< I_{max}$
- Various safety and operational characteristics as listed in the table below
- Approved for installation in hazardous areas (refer to certificate).
- Return diode causes a 3.5 voltage drop

Technical tips

- Not short circuit proof
- $T_a = 140\text{ }^\circ\text{F}$ ($60\text{ }^\circ\text{C}$) except for 9001/03-280-000-101 in FM / UL / ATEX installations where $T_a = 122\text{ }^\circ\text{F}$ ($50\text{ }^\circ\text{C}$)

FM / UL Information – Ex Interface to Class I, II, III, Division 1 or Class I, Zone 0										
Product Type	Operational Characteristics		Entity Parameters			Gas Group Cable Parameters				Art. No.
	V_{nom}	I_{max}	U_0/V_{oc}	I_0/I_{sc}	P_o	L_0/L_c for A, B, E or IIC	C_0/C_s for A,B,E or IIC	L_0/L_c for C, D, F, G or IIB, IIA	C_0/C_s for C, D, F, G or IIB, IIA	
9001/03-199-000-101	16 V	$< 100\text{ mA}$	19.9 V	0 mA	0 mW	1000 mH	0.223 μF	1000 mH	1.42 μF	158475
9001/03-280-000-101	24 V	$< 100\text{ mA}$	28 V	0 mA	0 mW	50 mH	0.083 μF	50 mH	0.65 μF	158486

08 b

CSA Information – Ex Interface to Class I, II, III, Division 1											
Product Type	Operational Characteristics		Entity Parameters			Gas Group Cable Parameters				Art. No.	
	V_{nom}	R_{min}	I_{max}	U_0/V_{oc}	I_0/I_{sc}	P_o	L_0/L_c for A, B, E	C_0/C_s for A, B, E	L_0/L_c for C, D, F, G		C_0/C_s for C, D, F, G
9001/03-199-000-101	16 V	Diode *	$< 100\text{ mA}$	19.8 V	0 mA	0 mW	1000 mH	0.34 μF	1000 mH	1.02 μF	158475
9001/03-280-000-101	24 V	Diode *	$< 100\text{ mA}$	28 V	0 mA	0 mW	1000 mH	0.14 μF	1000 mH	0.43 μF	158486

CSA Information – Ex Interface to Class I, Zone 0											
Product Type	Operational Characteristics		Entity Parameters			Gas Group Cable Parameters				Art. No.	
	V_{nom}	R_{min}	I_{max}	U_0/V_{oc}	I_0/I_{sc}	P_o	L_0/L_c for IIC	C_0/C_s for IIC	L_0/L_c for IIA, IIB		C_0/C_s for IIA, IIB
9001/03-199-000-101	16 V	Diode *	$< 100\text{ mA}$	19.9 V	0 mA	0 mW	1000 mH	0.223 μF	1000 mH	1.42 μF	158475
9001/03-280-000-101	24 V	Diode *	$< 100\text{ mA}$	28 V	0 mA	0 mW	50 mH	0.083 μF	50 mH	0.65 μF	158486

ATEX Information – Ex Interface to Zone 0										
Product Type	Operational Characteristics		Entity Parameters			Gas Group Cable Parameters				Art. No.
	V_{nom}	I_{max}	U_0/V_{oc}	I_0/I_{sc}	P_o	L_0/L_c for IIC	C_0/C_s for IIC	L_0/L_c for IIB	C_0/C_s for IIB	
9001/03-199-000-101	16 V	$< 100\text{ mA}$	19.9 V	0 mA	0 mW	1000 mH	0.223 μF	1000 mH	1.42 μF	158475
9001/03-280-000-101	24 V	$< 100\text{ mA}$	28 V	0 mA	0 mW	50 mH	0.083 μF	50 mH	0.65 μF	158486

Diode*: designates diode return

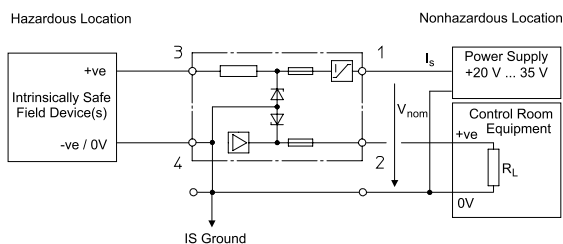

- Application specific for HART / SMART transmitters
- Grounded field device
- Input to control system elevated above 0 V
- Allows the connection of unregulated power supplies, V_{nom} between +20 to 35 V DC
- Approved for installation in hazardous areas (refer to certificate).

Technical tips

- $R_L \leq 350 \Omega$
- Transmitter supply voltage = 14 V when $V_{nom} > 23.5 V$
- Transmitter supply voltage = $V_{nom} - 9.5 V$ when $V_{nom} \leq 23.5 V$

FM / UL Information – Ex Interface to Class I, II, III, Division 1 or Class I, Zone 0

Product Type	Operational Characteristics				Entity Parameters				Gas Group Cable Parameters				Art. No.
	V_{nom}	U_o/V_{oc}	I_o/I_{sc}	P_o	L_o/L_s for A, B, E or IIC	C_o/C_s for A,B,E or IIC	L_o/L_s for C, D, F, G or IIB, IIA	C_o/C_s for C, D, F, G or IIB, IIA					
9001/51-280-091-141	20 ... 35 V	28 V	91 mA	637 mW	2.2 mH	0.083 μ F	14 mH	0.65 μ F	158524				

CSA Information – Ex Interface to Class I, II, III, Division 1

Product Type	Operational Characteristics		Entity Parameters			Gas Group Cable Parameters				Art. No.
	V_{nom}	R_{min}	U_o/V_{oc}	I_o/I_{sc}	P_o	L_o/L_s for A, B, E	C_o/C_s for A, B, E	L_o/L_s for C, D, F, G	C_o/C_s for C, D, F, G	
9001/51-280-091-141	20 ... 35 V	320 Ω	28.1 V	88 mA	637 mW	4.5 mH	0.14 μ F	17.6 mH	0.43 μ F	158524

CSA Information – Ex Interface to Class I, Zone 0

Product Type	Operational Characteristics		Entity Parameters			Gas Group Cable Parameters				Art. No.
	V_{nom}	R_{min}	U_o/V_{oc}	I_o/I_{sc}	P_o	L_o/L_s for IIC	C_o/C_s for IIC	L_o/L_s for IIA, IIB	C_o/C_s for IIA, IIB	
9001/51-280-091-141	20 ... 35 V	320 Ω	28 V	91 mA	637 mW	2.2 mH	0.083 μ F	14 mH	0.65 μ F	158524

ATEX Information – Ex Interface to Zone 0

Product Type	Operational Characteristics				Entity Parameters				Gas Group Cable Parameters				Art. No.
	V_{nom}	U_o/V_{oc}	I_o/I_{sc}	P_o	L_o/L_s for IIC	C_o/C_s for IIC	L_o/L_s for IIB	C_o/C_s for IIB					
9001/51-280-091-141	20 ... 35 V	28 V	91 mA	637 mW	2.2 mH	0.083 μ F	14 mH	0.65 μ F	158524				

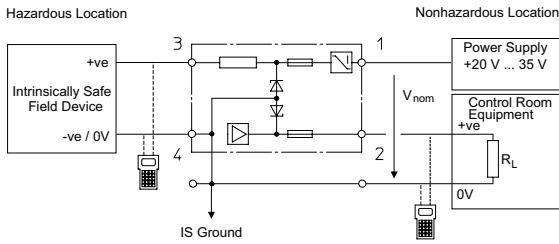

- Application specific for HART transmitters
- Grounded field device
- Input to control system elevated above 0 V
- Allows the connection of unregulated power supplies, V_{nom} between +20 to 35 V DC
- Approved for installation in hazardous areas (refer to certificate).

Technical tips

- $R_L \leq 500 \Omega$ when $V_{nom} \leq 23.5 V$
- $R_L \leq 750 \Omega$ when $V_{nom} > 23.5 V$
- Transmitter supply voltage = 15 V when $V_{nom} > 23.5 V$
- Transmitter supply voltage = $V_{nom} - 8.5 V$ when $V_{nom} \leq 23.5 V$
- $T_a = 104 \text{ }^\circ\text{F}$ (40 $^\circ\text{C}$) for FM / UL installations

FM / UL Information – Ex Interface to Class I, II, III, Division 1 or Class I, Zone 0									
Product Type	Operational Characteristics	Entity Parameters			Gas Group Cable Parameters				Art. No.
	V_{nom}	U_i/V_{oc}	I_i/I_{sc}	P_o	L_j/L_s for A, B, E or IIC	C_j/C_s for A, B, E or IIC	L_j/L_s for C, D, F, G or IIB, IIA	C_j/C_s for C, D, F, G or IIB, IIA	
9001/51-280-110-141	20 ... 35 V	28 V	110 mA	770 mW	1.2 mH	0.083 μF	9 mH	0.65 μF	158530

08 b

CSA Information – Ex Interface to Class I, II, III, Division 1									
Product Type	Operational Characteristics	Entity Parameters			Gas Group Cable Parameters				Art. No.
	V_{nom}	U_i/V_{oc}	I_i/I_{sc}	P_o	L_j/L_s for A, B, E	C_j/C_s for A, B, E	L_j/L_s for C, D, F, G	C_j/C_s for C, D, F, G	
9001/51-280-110-141	20 ... 35 V	28.1 V	106 mA	770 mW	3.2 mH	0.14 μF	12.4 mH	0.43 μF	158530

CSA Information – Ex Interface to Class I, Zone 0									
Product Type	Operational Characteristics	Entity Parameters			Gas Group Cable Parameters				Art. No.
	V_{nom}	U_i/V_{oc}	I_i/I_{sc}	P_o	L_j/L_s for IIC	C_j/C_s for IIC	L_j/L_s for IIA, IIB	C_j/C_s for IIA, IIB	
9001/51-280-110-141	20 ... 35 V	28 V	110 mA	770 mW	1.2 mH	0.083 μF	9 mH	0.65 μF	158530

ATEX Information – Ex Interface to Zone 0									
Product Type	Operational Characteristics	Entity Parameters			Gas Group Cable Parameters				Art. No.
	V_{nom}	U_i/V_{oc}	I_i/I_{sc}	P_o	L_j/L_s for IIC	C_j/C_s for IIC	L_j/L_s for IIB	C_j/C_s for IIB	
9001/51-280-110-141	20 ... 35 V	28 V	110 mA	770 mW	1.2 mH	0.083 μF	9 mH	0.65 μF	158530



- For the intrinsically safe operation of a wide range of devices, such as HART transmitters, solenoid valves, sensors, zero-potential contacts and many more
- Compact, space-saving devices that are easy to install on a DIN rail
- Quick and efficient installation as barriers can be simultaneously snapped onto DIN rail and connected to ground (ISA - RPI12.06)

WebCode **9002A**



The 9002 series INTRINSPAK two-channel zener barriers enable the intrinsically safe operation of virtually all field devices. The comprehensive portfolio and the combination of zener barriers cover a wide variety of signals. The devices are incredibly robust and require very little space. The back-up fuse is a convenient feature as it is standardized for all variants.

08 b

	NEC® 500 CEC Appendix J						CEC Section 18						IECEX / ATEX							
	Class I		Class II		Class III		NEC® 505 Class I			NEC® 506										
Division	1	2	1	2	1	2	Zone	0	1	2	20	21	22	Zone	0	1	2	20	21	22
Ex interface	•	•	•	•	•	•	Ex interface	•	•	•				Ex interface	•	•	•	•	•	•
Installation in		•					Installation in		•					Installation in		•				

Schematics of the zener barriers available at r-stahl.com

Technical Data	
Variant	Dual-channel safety barrier Series 9002
Explosion Protection	
USA certificate FM	3010778
USA certificate UL	E81680V1S3
CAN certificate CSA	1284580
USA marking FM	Nonincendive for Class I, Div.2, Groups A,B,C,D, T4 Class I, Zone 2, Groups IIC T4 Intrinsically safe connections for Class I,II,III, Div. 1, Groups A,B,C,D,E,F,G and Class I, Zone 0 Groups IIC/IIB, Hazardous Location When installed per doc. 90 026 11 31 1
USA marking UL	For use in Hazardous location Class I, Div. 2, Groups A,B,C,D, T4 Providing IS circuits for Class I, Groups A,B,C,D Class II, Groups E,F,G Class III per doc. 90 026 11 31 3
CAN marking CSA	Associated equipment [Ex ia] Class I, Div. 2, Groups A,B,C,D Provides intrinsically safe circuits for Class I,II,III; or Class I, Zone 0 Groups IIC/IIB For applicable groups per installation doc. 90 026 11 31 2
IECEX gas explosion protection	Ex nA [ja Ga] IIC/IIB T4 Gc
IECEX dust explosion protection	[Ex ia Da] IIIC

Technical Data	
Variant	Dual-channel safety barrier Series 9002
Explosion Protection	
Certificates	ATEX (PTB), Brazil (ULB), Canada (CSA), China (CQST), EAC (STV), IECEx (PTB), India (PESO), Korea (KGS), USA (FM), USA (UL)
Installation	in Zone 2, Division 2 and in safe area
Further information	see respective certificate and operating instructions
Notes	<p>9002/00-280-186-001 and 9002/11-280-186-001</p> <p>Gas explosion protection USA FM: Class I, Div. 2, Groups C and D; Class I, Zone 2, IIC, T4</p> <p>Gas explosion protection USA UL: Class I, Div. 2, Groups C,D, T4</p> <p>Intrinsically safe connection USA FM: Associated equipment [Ex ia] Class I, Div. 2, Groups A,B,C,D Provides intrinsically safe circuits for Class I,II,III; or Class I, Zone 0 Groups IIB For applicable groups per installation doc. 90 026 11 31 2</p> <p>Intrinsically safe connection USA UL: For use in Hazardous location Class I, Div. 2, Groups A,B,C,D, T4 Providing IS circuits for Class I, Groups A,B,C,D Class II, Groups E,F,G Class III per doc. 90 026 11 31 3</p> <p>Gas Explosion Protection Canada CSA: Class I, Div. 2, Groups C and D; Class I, Zone 2, IIC, T4</p> <p>Intrinsically safe connection Canada CSA: Associated equipment [Ex ia] Class I, Div. 2, Groups A,B,C,D Provides intrinsically safe circuits for Class I,II,III; or Class I, Zone 0 Groups IIB For applicable groups per installation doc. 90 026 11 31 2</p>
Electrical Data	
Resistive current limitation using frequency ≥ 50 mA	≤ 100 kHz
Resistive current limitation using frequency ≤ 50 mA	≤ 50 kHz
Leakage current I_{leak} for U_N	≤ 2 μ A
Leakage current I_{leak} for $U_N 2$	(Unless specified otherwise)
Notes	<p>9002/11-130-360-001 Leakage current I_{leak} for U_N ≤ 10 μA</p> <p>9002/13-252-121-041 Leakage current I_{leak} for U_N 35 V ≤ 10 mA</p>
Ambient Conditions	
Ambient temperature °F	-4°F ... +140°F
Ambient temperature °C	-20 °C ... +60 °C
Storage temperature °F	-4°F ... +167°F
Storage temperature °C	-20 °C ... +75 °C
Max. relative humidity	95% on average, no condensation
Temperature influence	$\leq 0,25$ %/10K
Notes	<p>9002/77-220-146-001 Ambient temperature -4°F ... +140°F / -20 °C ... +50 °C</p>
Mechanical Data	
Degree of protection (IP)	IP40
Terminal degree of protection (IP)	IP20
Enclosure material	Polyamide 6GF

08 b

Technical Data

Variante Dual-channel safety barrier Series 9002

Mechanical Data

Number of connection terminals	4
Type of connection cable	Solid Finely stranded
Conductor cross-section AWG max.	16 AWG
Connection cross section max.	1.5 mm ²
Weight	0.24 lb
Weight	0.11 kg

Mounting / Installation

Connection type	2 PA
Cross-section ground AWG	12 AWG
Connection cross-section ground	4 mm ²
Min. torque lb / in	4.43 lb / in
Min. torque Nm	0.5 Nm
Max. torque lb / in	5.31 lb / in
Max. torque Nm	0.6 Nm

Accessories and Spare Parts see page 264

Dimensional Drawings see page 265

08 b

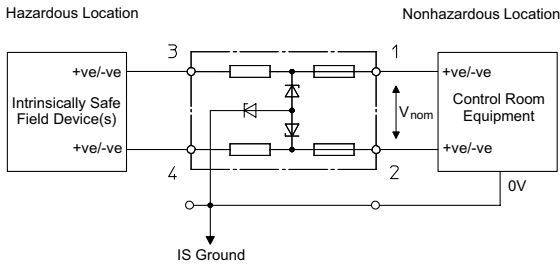

- Allows the connection of a voltage, V_{nom} , between the two channels as listed in the table below
- Suitable for voltage signals
- Various safety and operational characteristics as listed in the table below
- Approved for installation in hazardous areas (refer to certificate).

- When two Channels of one barrier are connected together to one field device with no isolation between the channels, the resultant entity Parameters, V_T , I_T , P_o , and cable parameters, must be used and are as listed in row (1+2) for each barrier.
- High cable capacitance or inductance figures are available due to the two channels in a star connected barrier being interlocked.
- The polarity of the voltage must be equal on each channel, i.e. both +DC, both -DC or both AC.
- Mixing polarity is not allowed.

FM / UL Information – Ex Interface to Class I, II, III, Division 1 or Class I, Zone 0												
Product Type	Operational Characteristics			Entity Parameters			Gas Group Cable Parameters				Art. No.	
	Channel	V_{nom}	R_{min}	R_{max}	U_i/V_{oc}	I_i/I_{sc}	P_o	L_i/L_c for A, B, E or IIC	C_i/C_c for A, B, E or IIC	L_i/L_c for C, D, F, G or IIB, IIA		C_i/C_c for C, D, F, G or IIB, IIA
9002/77-093-040-001	1		492 Ω	546 Ω	9.3 V	20 mA	0.05 mW	90 mH	4.1 μF	330 mH	31 μF	158905
	2		492 Ω	546 Ω	9.3 V	20 mA	0.05 mW	90 mH	4.1 μF	330 mH	31 μF	
	1+2	6 V			9.3 V	40 mA	0.09 mW	23 mH	4.1 μF	87 mH	31 μF	
9002/77-093-300-001	1		71.7 Ω	81.5 Ω	9.3 V	150 mA	0.35 mW	1.3 mH	4.1 μF	7 mH	31 μF	158897
	2		71.7 Ω	81.5 Ω	9.3 V	150 mA	0.35 mW	1.3 mH	4.1 μF	7 mH	31 μF	
	1+2	6 V			9.3 V	300 mA	0.7 mW	0.2 mH	4.1 μF	1.8 mH	31 μF	
9002/77-100-400-001	1		60.3 Ω	68.9 Ω	10 V	200 mA	0.5 mW	0.5 mH	3 μF	4 mH	20.2 μF	158893
	2		60.3 Ω	68.9 Ω	10 V	200 mA	0.5 mW	0.5 mH	3 μF	4 mH	20.2 μF	
	1+2	6 V			10 V	400 mA	1 mW	0.15 mH	3 μF	0.8 mH	20.2 μF	
9002/77-150-300-001	1		112 Ω	126 Ω	15 V	150 mA	0.56 mW	1.3 mH	0.58 μF	7 mH	3.55 μF	158889
	2		112 Ω	126 Ω	15 V	150 mA	0.56 mW	1.3 mH	0.58 μF	7 mH	3.55 μF	
	1+2	12 V			15 V	300 mA	1.13 mW	0.2 mH	0.58 μF	1.8 mH	3.55 μF	
9002/77-220-146-001	1		322 Ω	359 Ω	22 V	73 mA	0.4 mW	7 mH	0.165 μF	26 mH	1.14 μF	158885
	2		322 Ω	359 Ω	22 V	73 mA	0.4 mW	7 mH	0.165 μF	26 mH	1.14 μF	
	1+2	18 V			22 V	146 mA	0.8 mW	1.4 mH	0.165 μF	7.4 mH	1.14 μF	
9002/77-280-094-001	1		657 Ω	731 Ω	28 V	47 mA	0.33 mW	10.1 mH	0.083 μF	30 mH	0.65 μF	158877
	2		657 Ω	731 Ω	28 V	47 mA	0.33 mW	10.1 mH	0.083 μF	30 mH	0.65 μF	
	1+2	24 V			28 V	94 mA	0.66 mW	1.96 mH	0.083 μF	12.5 mH	0.65 μF	

CSA Information – Ex Interface to Class I, II, III, Division 1												
Product Type	Operational Characteristics			Entity Parameters			Gas Group Cable Parameters				Art. No.	
	Channel	V_{nom}	R_{min}	R_{max}	U_i/V_{oc}	I_i/I_{sc}	P_o	L_i/L_c for A, B, E	C_i/C_c for A, B, E	L_i/L_c for C, D, F, G		C_i/C_c for C, D, F, G
9002/77-093-040-001	1		475 Ω	546 Ω	9.3 V	20 mA	0.05 W	90 mH	4.1 μF	330 mH	31 μF	158905
	2		475 Ω	546 Ω	9.3 V	20 mA	0.05 W	90 mH	4.1 μF	330 mH	31 μF	
	1+2	6 V	-	-	9.3 V	40 mA	0.09 W	23 mH	4.1 μF	87 mH	31 μF	
9002/77-093-300-001	1		68 Ω	81.5 Ω	9.3 V	150 mA	0.35 W	1.3 mH	4.1 μF	7 mH	31 μF	158897
	2		68 Ω	81.5 Ω	9.3 V	150 mA	0.35 W	1.3 mH	4.1 μF	7 mH	31 μF	
	1+2	6 V	-	-	9.3 V	300 mA	0.7 W	0.2 mH	4.1 μF	1.8 mH	31 μF	
9002/77-100-400-001	1		56 Ω	68.9 Ω	9.9 V	190 mA	0.5 W	0.59 mH	3.3 μF	4.6 mH	9.9 μF	158893
	2		56 Ω	68.9 Ω	9.9 V	190 mA	0.5 W	0.59 mH	3.3 μF	4.6 mH	9.9 μF	
	1+2	6 V	-	-	9.9 V	380 mA	1 W	0.16 mH	3.3 μF	0.9 mH	9.9 μF	
9002/77-150-300-001	1		110 Ω	126 Ω	14.5 V	140 mA	0.56 W	1.6 mH	0.58 μF	8.1 mH	2.5 μF	158889
	2		110 Ω	126 Ω	14.5 V	140 mA	0.56 W	1.6 mH	0.58 μF	8.1 mH	2.5 μF	
	1+2	12 V	-	-	14.5 V	280 mA	1.13 W	0.21 mH	0.58 μF	2 mH	2.5 μF	
9002/77-220-146-001	1		330 Ω	359 Ω	21.8 V	70 mA	0.4 W	7.4 mH	0.25 μF	28.5 mH	0.76 μF	158885
	2		330 Ω	359 Ω	21.8 V	70 mA	0.4 W	7.4 mH	0.25 μF	28.5 mH	0.76 μF	
	1+2	18 V	-	-	21.8 V	140 mA	0.8 W	1.6 mH	0.25 μF	8.1 mH	0.76 μF	
9002/77-280-094-001	1		680 Ω	731 Ω	28.1 V	44 mA	0.33 W	18.5 mH	0.14 μF	67 mH	0.41 μF	158877
	2		680 Ω	731 Ω	28.1 V	44 mA	0.33 W	18.5 mH	0.14 μF	67 mH	0.41 μF	
	1+2	24 V	-	-	28.1 V	88 mA	0.66 W	4.8 mH	0.14 μF	19 mH	0.4 μF	

08b

CSA Information – Ex Interface to Class I, Zone 0

Product Type	Operational Characteristics			Entity Parameters			Gas Group Cable Parameters				Art. No.	
	Channel	V _{nom}	R _{min}	R _{max}	U ₀ /V _{oc}	I ₀ /I _{sc}	P ₀	L ₀ /L _s for IIC	C ₀ /C _s for IIC	L ₀ /L _s for IIA, IIB		C ₀ /C _s for IIA, IIB
9002/77-093-040-001	1		475 Ω	546 Ω	9.3 V	20 mA	0.05 W	90 mH	4.1 μF	330 mH	31 μF	158905
	2		475 Ω	546 Ω	9.3 V	20 mA	0.05 W	90 mH	4.1 μF	330 mH	31 μF	
	1+2	6 V	-	-	9.3 V	40 mA	0.09 W	23 mH	4.1 μF	87 mH	31 μF	
9002/77-093-300-001	1		68 Ω	81.5 Ω	9.3 V	150 mA	0.35 W	1.3 mH	4.1 μF	7 mH	31 μF	158897
	2		68 Ω	81.5 Ω	9.3 V	150 mA	0.35 W	1.3 mH	4.1 μF	7 mH	31 μF	
	1+2	6 V	-	-	9.3 V	300 mA	0.7 W	0.2 mH	4.1 μF	1.8 mH	31 μF	
9002/77-100-400-001	1		56 Ω	68.9 Ω	10 V	200 mA	0.5 W	0.5 mH	3 μF	4 mH	20.2 μF	158893
	2		56 Ω	68.9 Ω	10 V	200 mA	0.5 W	0.5 mH	3 μF	4 mH	20.2 μF	
	1+2	6 V	-	-	10 V	400 mA	1 W	0.15 mH	3 μF	0.8 mH	20.2 μF	
9002/77-150-300-001	1		110 Ω	126 Ω	15 V	150 mA	0.56 W	1.3 mH	0.58 μF	7 mH	3.55 μF	158889
	2		110 Ω	126 Ω	15 V	150 mA	0.56 W	1.3 mH	0.58 μF	7 mH	3.55 μF	
	1+2	12 V	-	-	15 V	300 mA	1.13 W	0.2 mH	0.58 μF	1.8 mH	3.55 μF	
9002/77-220-146-001	1		330 Ω	359 Ω	22 V	73 mA	0.4 W	7 mH	0.165 μF	26 mH	1.14 μF	158885
	2		330 Ω	359 Ω	22 V	73 mA	0.4 W	7 mH	0.165 μF	26 mH	1.14 μF	
	1+2	18 V	-	-	22 V	146 mA	0.8 W	1.4 mH	0.165 μF	7.4 mH	1.14 μF	
9002/77-280-094-001	1		680 Ω	731 Ω	28 V	47 mA	0.33 W	10.1 mH	0.083 μF	30 mH	0.65 μF	158877
	2		680 Ω	731 Ω	28 V	47 mA	0.33 W	10.1 mH	0.083 μF	30 mH	0.65 μF	
	1+2	24 V	-	-	28 V	94 mA	0.66 W	1.96 mH	0.083 μF	12.5 mH	0.65 μF	

ATEX Information – Ex Interface to Zone 0

Product Type	Operational Characteristics			Entity Parameters			Gas Group Cable Parameters				Art. No.	
	Channel	V _{nom}	R _{min}	R _{max}	U ₀ /V _{oc}	I ₀ /I _{sc}	P ₀	L ₀ /L _s for IIC	C ₀ /C _s for IIC	L ₀ /L _s for IIB		C ₀ /C _s for IIB
9002/77-093-040-001	1		492 Ω	546 Ω	9.3 V	20 mA	50 mW	90 mH	4.1 μF	330 mH	31 μF	158905
	2		492 Ω	546 Ω	9.3 V	20 mA	50 mW	90 mH	4.1 μF	330 mH	31 μF	
	1+2	6 V	-	-	9.3 V	40 mA	90 mW	23 mH	4.1 μF	87 mH	31 μF	
9002/77-093-300-001	1		71.7 Ω	81.5 Ω	9.3 V	150 mA	350 mW	1.3 mH	4.1 μF	7 mH	31 μF	158897
	2		71.7 Ω	81.5 Ω	9.3 V	150 mA	350 mW	1.3 mH	4.1 μF	7 mH	31 μF	
	1+2	6 V	-	-	9.3 V	300 mA	700 mW	0.2 mH	4.1 μF	1.8 mH	31 μF	
9002/77-100-400-001	1		60.3 Ω	68.9 Ω	10 V	200 mA	500 mW	0.5 mH	3 μF	4 mH	20.2 μF	158893
	2		60.3 Ω	68.9 Ω	10 V	200 mA	500 mW	0.5 mH	3 μF	4 mH	20.2 μF	
	1+2	6 V	-	-	10 V	400 mA	1000 mW	0.15 mH	3 μF	0.8 mH	20.2 μF	
9002/77-150-300-001	1		112 Ω	126 Ω	15 V	150 mA	560 mW	1.3 mH	0.58 μF	7 mH	3.55 μF	158889
	2		112 Ω	126 Ω	15 V	150 mA	560 mW	1.3 mH	0.58 μF	7 mH	3.55 μF	
	1+2	12 V	-	-	15 V	300 mA	1130 mW	0.2 mH	0.58 μF	1.8 mH	3.55 μF	
9002/77-220-146-001	1		322 Ω	359 Ω	22 V	73 mA	400 mW	7 mH	0.165 μF	26 mH	1.14 μF	158885
	2		322 Ω	359 Ω	22 V	73 mA	400 mW	7 mH	0.165 μF	26 mH	1.14 μF	
	1+2	18 V	-	-	22 V	296 mA	800 mW	1.4 mH	0.165 μF	7.4 mH	1.14 μF	
9002/77-280-094-001	1		657 Ω	731 Ω	28 V	94 mA	330 mW	10.1 mH	0.083 μF	30 mH	0.65 μF	158877
	2		657 Ω	731 Ω	28 V	47 mA	330 mW	10.1 mH	0.083 μF	30 mH	0.65 μF	
	1+2	24 V	-	-	28 V	94 mA	660 mW	1.96 mH	0.083 μF	12.5 mH	0.65 μF	

08 b

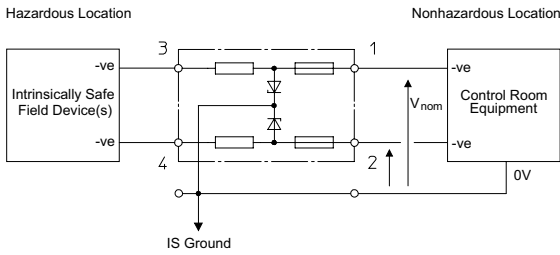

- Allows the connection of regulated power supplies, V_{nom} , as listed in the table below.
- Various safety and operational characteristics as listed in the table below
- Approved for installation in hazardous areas (refer to certificate).

- When two channels of one barrier are connected together to one field device with no isolation between the channels, the resultant entity parameters, V_T , I_T , P_o , and cable parameters, must be used and are as listed in row (1+2) for each barrier.

FM / UL Information – Ex Interface to Class I, II, III, Division 1 or Class I, Zone 0													
Product Type	Operational Characteristics					Entity Parameters			Gas Group Cable Parameters				Art. No.
	Channel	V_{nom}	R_{min}	R_{max}	I_{max}	U_o/V_{oc}	I_o/I_{sc}	P_o	L_o/L_s for A, B, E or IIC	C_o/C_s for A, B, E or IIC	L_o/L_s for C, D, F, G or IIB, IIA	C_o/C_s for C, D, F, G or IIB, IIA	
9002/00-260-138-001	1	22.5 V	321 Ω	359 Ω	62 mA	26 V	83 mA	0.54 mW	2.7 mH	0.099 μF	15.5 mH	0.77 μF	158867
	2	17.5 V	417 Ω	464 Ω	37 mA	20 V	49 mA	0.245 mW	14 mH	0.22 μF	54 mH	1.41 μF	
	1 + 2	-	-	-	-	27.4 V	132 mA	0.785 mW	0.81 mH	0.087 μF	5.1 mH	0.67 μF	
9002/00-280-186-001	1	25 V	322 Ω	359 Ω	69 mA	28 V	93 mA	0.65 mW	2 mH	0.083 μF	13 mH	0.65 μF	158845
	2	25 V	322 Ω	359 Ω	69 mA	28 V	93 mA	0.65 mW	2 mH	0.083 μF	13 mH	0.65 μF	
	1 + 2	-	-	-	-	30.1 V	186 mA	1.3 mW	-	-	2.8 mH	0.551 μF	

08 b

CSA Information – Ex Interface to Class I, II, III, Division 1													
Product Type	Operational Characteristics					Entity Parameters			Gas Group Cable Parameters				Art. No.
	Channel	V_{nom}	R_{min}	R_{max}	I_{max}	U_o/V_{oc}	I_o/I_{sc}	P_o	L_o/L_s for A, B, E	C_o/C_s for A, B, E	L_o/L_s for C, D, F, G	C_o/C_s for C, D, F, G	
9002/00-260-138-001	1	22.5 V	330 Ω	359 Ω	62 mA	-25.8 V	-82 mA	0.54 W	5.3 mH	0.17 μF	21 mH	0.5 μF	158867
	2	17.5 V	430 Ω	464 Ω	37 mA	-20.1 V	-49 mA	0.245 W	14.7 mH	0.31 μF	54 mH	0.96 μF	
	1 + 2	-	-	-	-	27.4 V	132 mA	0.785 W	8.9 mH	0.43 μF	1.9 mH	0.43 μF	
9002/00-280-186-001	1	25 V	330 Ω	359 Ω	69 mA	-28 V	-91 mA	0.65 W	4.5 mH	0.14 μF	18.1 mH	0.43 μF	158845
	2	25 V	330 Ω	359 Ω	69 mA	-28 V	-91 mA	0.65 W	4.5 mH	0.14 μF	18.1 mH	0.43 μF	
	1 + 2	-	-	-	-	30.4 V	183 mA	1.3 W	-	-	5 mH	0.34 μF	

CSA Information – Ex Interface to Class I, Zone 0													
Product Type	Operational Characteristics					Entity Parameters			Gas Group Cable Parameters				Art. No.
	Channel	V_{nom}	R_{min}	R_{max}	I_{max}	U_o/V_{oc}	I_o/I_{sc}	P_o	L_o/L_s for IIC	C_o/C_s for IIC	L_o/L_s for IIA, IIB	C_o/C_s for IIA, IIB	
9002/00-260-138-001	1	22.5 V	330 Ω	359 Ω	62 mA	26 V	83 mA	0.54 W	2.7 mH	0.099 μF	15.5 mH	0.77 μF	158867
	2	17.5 V	430 Ω	464 Ω	37 mA	20 V	49 mA	0.245 W	14 mH	0.22 μF	54 mH	1.41 μF	
	1 + 2	-	-	-	-	27.4 V	132 mA	0.785 W	0.81 mH	0.087 μF	5.1 mH	0.67 μF	
9002/00-280-186-001	1	25 V	330 Ω	359 Ω	69 mA	28 V	93 mA	0.65 W	2 mH	0.083 μF	13 mH	0.65 μF	158845
	2	25 V	330 Ω	359 Ω	69 mA	28 V	93 mA	0.65 W	2 mH	0.083 μF	13 mH	0.65 μF	
	1 + 2	-	-	-	-	30.1 V	186 mA	1.3 W	-	-	2.8 mH	0.551 μF	

ATEX Information – Ex Interface to Zone 0													
Product Type	Operational Characteristics					Entity Parameters			Gas Group Cable Parameters				Art. No.
	Channel	V_{nom}	R_{min}	R_{max}	I_{max}	U_o/V_{oc}	I_o/I_{sc}	P_o	L_o/L_s for IIC	C_o/C_s for IIC	L_o/L_s for IIB	C_o/C_s for IIB	
9002/00-260-138-001	1	22.5 V	321 Ω	359 Ω	62 mA	26 V	87 mA	540 mW	2.7 mH	0.099 μF	15.4 mH	0.77 μF	158867
	2	17.5 V	417 Ω	464 Ω	37 mA	20 V	51 mA	245 mW	14 mH	0.22 μF	54 mH	1.41 μF	
	1 + 2	-	-	-	-	26 V	138 mA	785 mW	0.81 mH	0.087 μF	5.1 mH	0.67 μF	
9002/00-280-186-001	1	25 V	322 Ω	359 Ω	69 mA	28 V	93 mA	650 mW	2 mH	0.083 μF	13 mH	0.65 μF	158845
	2	25 V	322 Ω	359 Ω	69 mA	28 V	93 mA	650 mW	2 mH	0.083 μF	13 mH	0.65 μF	
	1 + 2	-	-	-	-	28 V	186 mA	1300 mW	-	-	2.8 mH	0.551 μF	

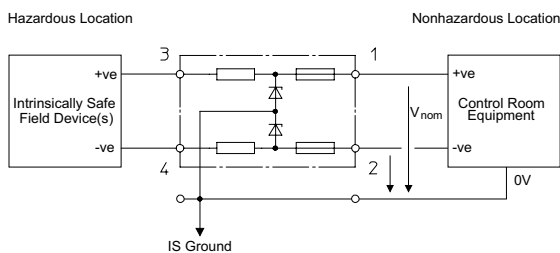

- Application specific for use with strain gauge load cells
- One positive polarity channel and one negative polarity channel in one unit
- Approved for installation in hazardous areas (refer to certificate).

- When two channels of one barrier are connected together to one field device with no isolation between the channels, the resultant entity parameters, V_T , I_T , P_O , and cable parameters, must be used and are as listed in row (1+2) for each barrier.

FM / UL Information – Ex Interface to Class I, II, III, Division 1 or Class I, Zone 0

Product Type	Operational Characteristics				Entity Parameters			Gas Group Cable Parameters				Art. No.	
	Channel	V_{nom}	R_{min}	R_{max}	I_{max}	U_0/V_{oc}	I_0/I_{sc}	P_o	L_0/L_s for A, B, E or IIC	C_0/C_s for A, B, E or IIC	L_0/L_s for C, D, F, G or IIB, IIA		C_0/C_s for C, D, F, G or IIB, IIA
9002/10-187-020-001	1	6 V	490 Ω	543 Ω	11 mA	9.33 V	20 mA	0.05 mW	90 mH	3.9 μF	330 mH	29 μF	158937
	2	6 V	490 Ω	543 Ω	11 mA	9.33 V	20 mA	0.05 mW	90 mH	3.9 μF	330 mH	29 μF	
	1+2					18.7 V	20 mA	0.09 mW	90 mH	0.27 μF	330 mH	1.64 μF	
9002/10-187-270-001	1	6 V	43 Ω	49 Ω	122 mA	9.33 V	270 mA	0.63 mW	0.23 mH	3.9 μF	2.2 mH	29 μF	158933
	2	6 V	43 Ω	49 Ω	122 mA	9.33 V	270 mA	0.63 mW	0.23 mH	3.9 μF	2.2 mH	29 μF	
	1+2					18.7 V	270 mA	1.26 mW	0.23 mH	0.27 μF	2.2 mH	1.64 μF	

CSA Information – Ex Interface to Class I, II, III, Division 1

Product Type	Operational Characteristics				Entity Parameters			Gas Group Cable Parameters				Art. No.	
	Channel	V_{nom}	R_{min}	R_{max}	I_{max}	U_0/V_{oc}	I_0/I_{sc}	P_o	L_0/L_s for A, B, E	C_0/C_s for A, B, E	L_0/L_s for C, D, F, G		C_0/C_s for C, D, F, G
9002/10-187-020-001	1	6 V	475 Ω	543 Ω	11 mA	9.3 V	19.8 mA	0.05 W	83.4 mH	4.3 μF	301 mH	12.9 μF	158937
	2	6 V	475 Ω	543 Ω	11 mA	9.3 V	19.8 mA	0.05 W	83.4 mH	4.3 μF	301 mH	12.9 μF	
	1+2					18.7 V	22 mA	0.09 W	68.3 mH	0.39 μF	248 mH	1.17 μF	
9002/10-187-270-001	1	6 V	39 Ω	49 Ω	122 mA	9.3 V	251.8 mA	0.63 W	0.27 mH	4.3 μF	2.4 mH	12.9 μF	158933
	2	6 V	39 Ω	49 Ω	122 mA	9.3 V	251.8 mA	0.63 W	0.27 mH	4.3 μF	2.4 mH	12.9 μF	
	1+2					18.7 V	278.8 mA	1.26 W	0.21 mH	0.39 μF	2 mH	1.17 μF	

CSA Information – Ex Interface to Class I, Zone 0

Product Type	Operational Characteristics				Entity Parameters			Gas Group Cable Parameters				Art. No.	
	Channel	V_{nom}	R_{min}	R_{max}	I_{max}	U_0/V_{oc}	I_0/I_{sc}	P_o	L_0/L_s for IIC	C_0/C_s for IIC	L_0/L_s for IIA, IIB		C_0/C_s for IIA, IIB
9002/10-187-020-001	1	6 V	475 Ω	543 Ω	11 mA	9.33 V	20 mA	0.05 W	90 mH	3.9 μF	330 mH	29 μF	158937
	2	6 V	475 Ω	543 Ω	11 mA	9.33 V	20 mA	0.05 W	90 mH	3.9 μF	330 mH	29 μF	
	1+2					18.7 V	20 mA	0.09 W	90 mH	0.27 μF	330 mH	1.64 μF	
9002/10-187-270-001	1	6 V	39 Ω	49 Ω	122 mA	9.33 V	270 mA	0.63 W	0.23 mH	3.9 μF	2.2 mH	29 μF	158933
	2	6 V	39 Ω	49 Ω	122 mA	9.33 V	270 mA	0.63 W	0.23 mH	3.9 μF	2.2 mH	29 μF	
	1+2					18.7 V	270 mA	1.26 W	0.23 mH	0.27 μF	2.2 mH	1.64 μF	

ATEX Information – Ex Interface to Zone 0

Product Type	Operational Characteristics				Entity Parameters			Gas Group Cable Parameters				Art. No.	
	Channel	V_{nom}	R_{min}	R_{max}	I_{max}	U_0/V_{oc}	I_0/I_{sc}	P_o	L_0/L_s for IIC	C_0/C_s for IIC	L_0/L_s for IIB		C_0/C_s for IIB
9002/10-187-020-001	1	6 V	490 Ω	543 Ω	11 mA	9.3 V	20 mA	50 mW	90 mH	3.9 μF	330 mH	29 μF	158937
	2	6 V	490 Ω	543 Ω	11 mA	9.3 V	20 mA	50 mW	90 mH	3.9 μF	330 mH	29 μF	
	1+2					18.7 V	20 mA	90 mW	90 mH	0.27 μF	330 mH	1.64 μF	
9002/10-187-270-001	1	6 V	43 Ω	49 Ω	122 mA	9.3 V	270 mA	630 mW	0.23 mH	3.9 μF	2.2 mH	29 μF	158933
	2	6 V	43 Ω	49 Ω	122 mA	9.3 V	270 mA	630 mW	0.23 mH	3.9 μF	2.2 mH	29 μF	
	1+2					18.7 V	270 mA	1260 mW	0.23 mH	0.27 μF	2.2 mH	1.64 μF	

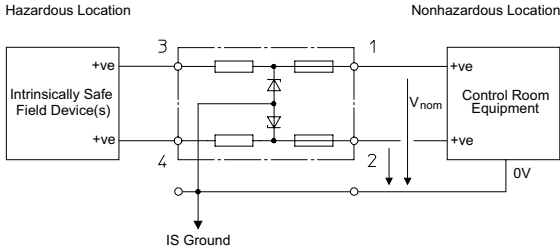

- Allows the connection of regulated power supplies, V_{nom} , as listed in the table below.
- Various safety and operational characteristics as listed in the table below
- Approved for installation in hazardous areas (refer to certificate).

- When two channels of one barrier are connected together to onefield device with no isolation between the channels, the resultant entity parameters, V_T , I_T , P_o , and cable parameters, must be used and are as listed in row (1+2) for each barrier.

FM / UL Information – Ex Interface to Class I, II, III, Division 1 or Class I, Zone 0													
Product Type	Operational Characteristics				Entity Parameters			Gas Group Cable Parameters				Art. No.	
	Channel	V_{nom}	R_{min}	R_{max}	I_{max}	U_o/V_{oc}	I_o/I_{sc}	P_o	L_o/L_c for A, B, E or IIC	C_o/C_c for A, B, E or IIC	L_o/L_c for C, D, F, G or IIB, IIA		C_o/C_c for C, D, F, G or IIB, IIA
9002/11-120-024-001	1	9 V	1052 Ω	1165 Ω	7,7 mA	12 V	12 mA	0.04 mW	240 mH	1.41 μF	850 mH	9 μF	158943
	2	25 V	1052 Ω	1165 Ω	7.7 mA	12 V	12 mA	0.04 mW	240 mH	1.41 μF	850 mH	9 μF	
	1 + 2		25 V	-	-	12.7 V	24 mA	0.07 mW	63 mH	1.1 μF	230 mH	7.1 μF	
9002/11-130-360-001	1	10 V	46 Ω	52 Ω	100 mA	13 V	321 mA	1.04 mW	0.19 mH	1 μF	1.6 mH	6.2 μF	158958
	2	1 V	46 Ω	52 Ω	19 mA	1.6 V	39 mA	0.016 mW	24 mH	100 μF	91 mH	1000 μF	
	1 + 2		1 V	-	-	13.3 V	360 mA	1.17 mW	0.17 mH	0.79 μF	1.3 mH	5 μF	
9002/11-199-030-001	1	16 V	1435 Ω	1590 Ω	10 mA	19.9 V	15 mA	0.075 mW	160 mH	0.223 μF	560 mH	1.42 μF	158929
	2	16 V	1435 Ω	1590 Ω	10 mA	19.9 V	15 mA	0.075 mW	160 mH	0.223 μF	560 mH	1.42 μF	
	1 + 2		16 V	-	-	20.6 V	30 mA	0.15 mW	40 mH	0.223 μF	150 mH	1.42 μF	
9002/11-280-186-001	1	25 V	322 Ω	359 Ω	69 mA	28 V	93 mA	0.65 mW	2 mH	0.083 μF	13 mH	0.65 μF	158848
	2	25 V	322 Ω	359 Ω	69 mA	28 V	93 mA	0.65 mW	2 mH	0.083 μF	13 mH	0.65 μF	
	1 + 2		25 V	-	-	30.1 V	186 mA	1.3 mW	-	-	2.8 mH	0.551 μF	
9002/11-280-293-001	1	25 V	322 Ω	359 Ω	69 mA	28 V	89 mA	0.63 mW	2.2 mH	0.083 μF	14 mH	0.65 μF	158864
	2	6 V	60 Ω	68 Ω	88 mA	9.56 V	180 mA	0.43 mW	0.6 mH	3.6 μF	5 mH	26 μF	
	1 + 2		6 V	-	-	28.7 V	269 mA	1.05 mW	-	-	0.56 mH	0.62 μF	

08 b

CSA Information – Ex Interface to Class I, II, III, Division 1													
Product Type	Operational Characteristics				Entity Parameters			Gas Group Cable Parameters				Art. No.	
	Channel	V_{nom}	R_{min}	R_{max}	I_{max}	U_o/V_{oc}	I_o/I_{sc}	P_o	L_o/L_c for A, B, E	C_o/C_c for A, B, E	L_o/L_c for C, D, F, G		C_o/C_c for C, D, F, G
9002/11-120-024-001	1	9 V	1020 Ω	1165 Ω	7,7 mA	11.6 V	11.4 mA	0.04 W	247 mH	1.8 μF	862 mH	5.5 μF	158943
	2	25 V	1020 Ω	1165 Ω	7.7 mA	11.6 V	11.4 mA	0.04 W	247 mH	1.8 μF	862 mH	5.5 μF	
	1 + 2		-	-	-	12.4 V	23 mA	0.07 W	64 mH	1.4 μF	226 mH	4.3 μF	
9002/11-130-360-001	1	10 V	41 Ω	52 Ω	100 mA	13 V	321 mA	1.04 W	0.19 mH	1 μF	1.6 mH	6.2 μF	158958
	2	1 V	41 Ω	52 Ω	19 mA	1.6 V	39 mA	0.016 W	24 mH	100 μF	91 mH	1000 μF	
	1 + 2		-	-	-	13.7 V	360 mA	1.17 W	0.17 mH	0.79 μF	1.3 mH	5 μF	
9002/11-199-030-001	1	16 V	1400 Ω	1590 Ω	10 mA	19.9 V	14.4 mA	0.075 W	157 mH	0.34 μF	511 mH	1 μF	158929
	2	16 V	1400 Ω	1590 Ω	10 mA	19.9 V	14.4 mA	0.075 W	157 mH	0.34 μF	511 mH	1 μF	
	1 + 2		-	-	-	20.6 V	29 mA	0.15 W	40.5 mH	0.3 μF	149 mH	0.9 μF	
9002/11-280-186-001	1	25 V	330 Ω	359 Ω	69 mA	28 V	91 mA	0.65 W	4.5 mH	0.14 μF	18.1 mH	0.43 μF	158848
	2	25 V	330 Ω	359 Ω	69 mA	28 V	91 mA	0.65 W	4.5 mH	0.14 μF	18.1 mH	0.43 μF	
	1 + 2		-	-	-	30.4 V	183 mA	1.3 W	-	-	5 mH	0.34 μF	
9002/11-280-293-001	1	25 V	330 Ω	359 Ω	69 mA	28 V	91 mA	0.63 W	4.5 mH	0.14 μF	18.1 mH	0.43 μF	158864
	2	6 V	56 Ω	68 Ω	88 mA	9.6 V	181 mA	0.43 W	0.7 mH	4.2 μF	5.2 mH	12.7 μF	
	1 + 2		-	-	-	28.8 V	272 mA	1.05 W	0.23 mH	0.13 μF	2.2 mH	0.4 μF	

CSA Information – Ex Interface to Class I, Zone 0													
Product Type	Operational Characteristics				Entity Parameters			Gas Group Cable Parameters				Art. No.	
	Channel	V_{nom}	R_{min}	R_{max}	I_{max}	U_o/V_{oc}	I_o/I_{sc}	P_o	L_o/L_c for IIC	C_o/C_c for IIC	L_o/L_c for IIA, IIB		C_o/C_c for IIA, IIB
9002/11-120-024-001	1	9 V	1020 Ω	1165 Ω	7,7 mA	12 V	12 mA	0.04 W	240 mH	1.41 μF	850 mH	9 μF	158943
	2	25 V	1020 Ω	1165 Ω	7.7 mA	12 V	12 mA	0.04 W	240 mH	1.41 μF	850 mH	9 μF	
	1 + 2		-	-	-	12.7 V	24 mA	0.07 W	63 mH	1.1 μF	230 mH	7.1 μF	

CSA Information – Ex Interface to Class I, Zone 0

Product Type	Operational Characteristics				Entity Parameters			Gas Group Cable Parameters				Art. No.
	Channel	V _{nom}	R _{min}	R _{max}	I _{max}	U ₀ /V _{oc}	I ₀ /I _{sc}	P ₀	L ₀ /L ₀ for IIC	C ₀ /C ₀ for IIC	L ₀ /L ₀ for IIA, IIB	
9002/11-130-360-001	1	10 V	41 Ω	52 Ω	100 mA	13 V	321 mA	1.04 W	0.19 mH	1 μF	1.6 mH	6.2 μF
	2	1 V	41 Ω	52 Ω	19 mA	1.6 V	39 mA	0.016 W	24 mH	100 μF	91 mH	1000 μF
	1 + 2	-	-	-	-	13.3 V	360 mA	1.17 W	0.17 mH	0.79 μF	1.3 mH	5 μF
9002/11-199-030-001	1	16 V	1400 Ω	1590 Ω	10 mA	19.9 V	15 mA	0.075 W	160 mH	0.223 μF	560 mH	1.42 μF
	2	16 V	1400 Ω	1590 Ω	10 mA	19.9 V	15 mA	0.075 W	160 mH	0.223 μF	560 mH	1.42 μF
	1 + 2	-	-	-	-	20.6 V	30 mA	0.15 W	40 mH	0.223 μF	150 mH	1.42 μF
9002/11-280-186-001	1	25 V	330 Ω	359 Ω	69 mA	28 V	93 mA	0.65 W	2 mH	0.083 μF	13 mH	0.65 μF
	2	25 V	330 Ω	359 Ω	69 mA	28 V	93 mA	0.65 W	2 mH	0.083 μF	13 mH	0.65 μF
	1 + 2	-	-	-	-	30.1 V	186 mA	1.3 W	-	-	2.8 mH	0.551 μF
9002/11-280-293-001	1	25 V	330 Ω	359 Ω	69 mA	28 V	89 mA	0.63 W	2.2 mH	0.083 μF	14 mH	0.65 μF
	2	6 V	56 Ω	68 Ω	88 mA	9.56 V	180 mA	0.43 W	0.6 mH	3.6 μF	5 mH	26 μF
	1 + 2	-	-	-	-	28.7 V	269 mA	1.05 W	-	-	0.56 mH	0.62 μF

ATEX Information – Ex Interface to Zone 0

Product Type	Operational Characteristics				Entity Parameters			Gas Group Cable Parameters				Art. No.
	Channel	V _{nom}	R _{min}	R _{max}	I _{max}	U ₀ /V _{oc}	I ₀ /I _{sc}	P ₀	L ₀ /L ₀ for IIC	C ₀ /C ₀ for IIC	L ₀ /L ₀ for IIB	
9002/11-120-024-001	1	9 V	1052 Ω	1165 Ω	7.7 mA	12 V	12 mA	40 mW	240 mH	1.41 μF	850 mH	9 μF
	2	25 V	1052 Ω	1165 Ω	7.7 mA	12 V	12 mA	40 mW	240 mH	1.41 μF	850 mH	9 μF
	1 + 2	-	-	-	-	12 V	24 mA	70 mW	63 mH	1.1 μF	230 mH	7.1 μF
9002/11-130-360-001	1	10 V	46 Ω	52 Ω	100 mA	13 V	321 mA	1040 mW	0.19 mH	1 μF	1.6 mH	6 μF
	2	1 V	46 Ω	52 Ω	19 mA	1.6 V	39 mA	16 mW	24 mH	100 μF	91 mH	1000 μF
	1 + 2	-	-	-	-	13 V	360 mA	1170 mW	0.17 mH	0.79 μF	1.3 mH	5 μF
9002/11-199-030-001	1	16 V	1435 Ω	1590 Ω	10 mA	19.9 V	15 mA	75 mW	160 mH	0.223 μF	560 mH	1.42 μF
	2	16 V	1435 Ω	1590 Ω	10 mA	19.9 V	15 mA	75 mW	160 mH	0.223 μF	560 mH	1.42 μF
	1 + 2	-	-	-	-	19.9 V	30 mA	150 mW	40 mH	0.223 μF	150 mH	1.42 μF
9002/11-280-186-001	1	25 V	322 Ω	359 Ω	69 mA	28 V	93 mA	650 mW	2 mH	0.083 μF	13 mH	0.65 μF
	2	25 V	322 Ω	359 Ω	69 mA	28 V	93 mA	650 mW	2 mH	0.83 μF	13 mH	0.65 μF
	1 + 2	-	-	-	-	28 V	186 mA	1300 mW	-	-	2.8 mH	0.551 μF
9002/11-280-293-001	1	25 V	322 Ω	359 Ω	69 mA	28 V	89 mA	630 mW	2.2 mH	0.083 μF	14 mH	0.65 μF
	2	6 V	60 Ω	68 Ω	88 mA	9.6 V	180 mA	430 mW	0.6 mH	3.6 μF	5 mH	26 μF
	1 + 2	-	-	-	-	28 V	269 mA	1050 mW	-	-	0.56 mH	0.62 μF

08 b

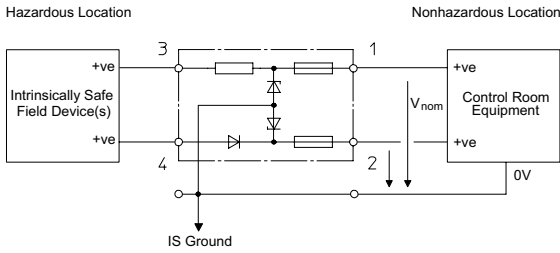

- Diode return barrier for supply and return signals in one unit with very small entity current (I_{sc}) addition from the second channel
- Allows the connection of regulated power supplies, V_{nom} , as listed in the table below
- Various safety and operational characteristics as listed in the table below
- Approved for installation in hazardous areas (refer to certificate).
- Return diode causes a 2 voltage drop

- When two channels of one barrier are connected together to one field device with no isolation between the channels, the resultant entity parameters, V_T , I_T , P_o , and cable parameters, must be used and are as listed in row (1+2) for each barrier.
- Not suitable for voltage signals or resistive sensors
- Maximum leakage current through channel 2 < 10 pA

FM / UL Information – Ex Interface to Class I, II, III, Division 1 or Class I, Zone 0													
Product Type	Operational Characteristics				Entity Parameters			Gas Group Cable Parameters				Art. No.	
	Channel	V_{nom}	R_{min}	R_{max}	I_{max}	U_j/V_{oc}	I_j/I_{sc}	P_o	L_j/L_s for A, B, E or IIC	C_j/C_s for A, B, E or IIC	L_j/L_s for C, D, F, G or IIA, IIB		C_j/C_s for C, D, F, G or IIA, IIB
9002/13-199-225-001	1	16 V	96 Ω	109 Ω	148 mA	19.9 V	222 mA	1.1 mW	0.39 mH	0.223 μF	3.18 mH	1.42 μF	158921
	2	16 V				19.9 V	3 mA	0.015 mW	1000 mH	0.223 μF	1000 mH	1.42 μF	
	1 + 2					20.2 V	225 mA	1.12 mW	0.37 mH	0.213 μF	3.15 mH	1.38 μF	
9002/13-280-093-001	1	24 V	322 Ω	359 Ω	67 mA	28 V	90 mA	0.63 mW	2.2 mH	0.083 μF	14 mH	0.65 μF	158852
	2	24 V				28 V	3 mA	0.021 mW	50 mH	0.083 μF	150 mH	0.65 μF	
	1 + 2					28.3 V	93 mA	0.651 mW	2 mH	0.08 μF	13 mH	0.636 μF	
9002/13-280-110-001	1	24 V	270 Ω	296 Ω	82 mA	28 V	107 mA	0.749 mW	1.35 mH	0.083 μF	9.6 mH	0.65 μF	158857
	2	24 V				28 V	3 mA	0.021 mW	50 mH	0.083 μF	150 mH	0.65 μF	
	1 + 2					28.3 V	110 mA	0.77 mW	1.25 mH	0.08 μF	9 mH	0.635 μF	

08 b

CSA Information – Ex Interface to Class I, II, III, Division 1													
Product Type	Operational Characteristics				Entity Parameters			Gas Group Cable Parameters				Art. No.	
	Channel	V_{nom}	R_{min}	R_{max}	I_{max}	U_j/V_{oc}	I_j/I_{sc}	P_o	L_j/L_s for A, B, E	C_j/C_s for A, B, E	L_j/L_s for C, D, F, G		C_j/C_s for C, D, F, G
9002/13-199-225-001	1	16 V	95 Ω	109 Ω	148 mA	19.8 V	220.3 mA	1.1 W	0.35 mH	0.33 μF	3.1 mH	1 μF	158921
	2	16 V	Diode *			8.6 V	0 mA	0.015 W	1000 mH	5.5 μF	1000 mH	16.5 μF	
	1 + 2					20.7 V	221 mA	1.12 W	0.35 mH	0.3 μF	2.8 mH	0.9 μF	
9002/13-280-093-001	1	24 V	330 Ω	359 Ω	67 mA	28 V	91 mA	0.63 W	4.4 mH	0.14 μF	17.2 mH	0.43 μF	158852
	2	24 V	Diode *			28 V	0 mA	0.021 W	1000 mH	0.14 μF	1000 mH	0.43 μF	
	1 + 2					30.4 V	91 mA	0.651 W	4.4 mH	0.1 μF	17.2 mH	0.3 μF	
9002/13-280-110-001	1	24 V	270 Ω	296 Ω	82 mA	28 V	110 mA	0.749 W	2.9 mH	0.13 μF	11.6 mH	0.39 μF	158857
	2	24 V	Diode *			28 V	0 mA	0.021 W	1000 mH	0.13 μF	1000 mH	0.39 μF	
	1 + 2					28.8 V	110 mA	0.77 W	2.9 mH	0.11 μF	11.6 mH	0.33 μF	

CSA Information – Ex Interface to Class I, Zone 0													
Product Type	Operational Characteristics				Entity Parameters			Gas Group Cable Parameters				Art. No.	
	Channel	V_{nom}	R_{min}	R_{max}	I_{max}	U_j/V_{oc}	I_j/I_{sc}	P_o	L_j/L_s for IIC	C_j/C_s for IIC	L_j/L_s for IIA, IIB		C_j/C_s for IIA, IIB
9002/13-199-225-001	1	16 V	95 Ω	109 Ω	148 mA	19.9 V	222 mA	1.1 W	0.39 mH	0.223 μF	3.18 mH	1.42 μF	158921
	2	16 V	Diode *			19.9 V	3 mA	0.015 W	1000 mH	0.223 μF	1000 mH	1.42 μF	
	1 + 2					20.2 V	225 mA	1.12 W	0.37 mH	0.213 μF	3.15 mH	1.38 μF	
9002/13-280-093-001	1	24 V	330 Ω	359 Ω	67 mA	28 V	90 mA	0.63 W	2.2 mH	0.083 μF	14 mH	0.65 μF	158852
	2	24 V	Diode *			28 V	3 mA	0.021 W	50 mH	0.083 μF	150 mH	0.65 μF	
	1 + 2					28.3 V	93 mA	0.651 W	2 mH	0.08 μF	13 mH	0.636 μF	
9002/13-280-110-001	1	24 V	270 Ω	296 Ω	82 mA	28 V	107 mA	0.749 W	1.35 mH	0.083 μF	9.6 mH	0.65 μF	158857
	2	24 V	Diode *			28 V	3 mA	0.021 W	50 mH	0.083 μF	150 mH	0.65 μF	
	1 + 2					28.3 V	110 mA	0.77 W	1.25 mH	0.08 μF	9 mH	0.635 μF	

ATEX Information – Ex Interface to Zone 0													
Product Type	Operational Characteristics				Entity Parameters			Gas Group Cable Parameters				Art. No.	
	Channel	V _{nom}	R _{min}	R _{max}	I _{max}	U _o /V _{oc}	I _o /I _{sc}	P _o	L _l /L _s for IIC	C _l /C _s for IIC	L _l /L _s for IIB		C _l /C _s for IIB
9002/13-199-225-001	1	16 V	96 Ω	109 Ω	148 mA	19.9 V	222 mA	1100 mW	0.39 mH	0.223 μF	3.18 mH	1.42 μF	158921
	2	16 V				19.9 V	3 mA	15 mW	1000 mH	0.223 μF	1000 mH	1.42 μF	
	1 + 2					19.9 V	225 mA	1120 mW	0.37 mH	0.213 μF	3.15 mH	1.38 μF	
9002/13-280-093-001	1	24 V	322 Ω	359 Ω	67 mA	28 V	90 mA	630 mW	2.2 mH	0.083 μF	14 mH	0.65 μF	158852
	2	24 V				28 V	3 mA	21 mW	50 mH	0.083 μF	150 mH	0.65 μF	
	1 + 2					28 V	93 mA	651 mW	2 mH	0.8 μF	13 mH	0.636 μF	
9002/13-280-110-001	1	24 V	270 Ω	296 Ω	82 mA	28 V	107 mA	749 mW	1.35 mH	0.083 μF	9.6 mH	0.65 μF	158857
	2	24 V				28 V	3 mA	21 mW	50 mH	0.083 μF	150 mH	0.65 μF	
	1 + 2					28 V	110 mA	770 mW	1.25 mH	0.8 μF	9 mH	0.635 μF	

Diode*: designates diode return

Zener Barriers Potential: Positive / Diode Return Barriers Potential: Positive

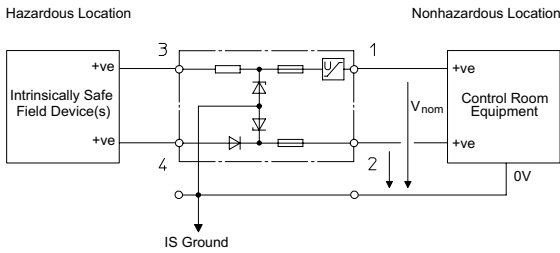

- Diode return barrier for supply and return signals in one unit with very small entity current (I_{sc}) addition from the second channel
- Operational current limited to 40 mA at 250 Ω load
- Allows the connection of unregulated power supplies, V_{nom} to channel 1
- Approved for installation in hazardous areas (refer to certificate).
- Return diode causes a 3.5 voltage drop

- When two channels of one barrier are connected together to one field device with no isolation between the channels, the resultant entity parameters, V_T , I_T , P_o , and cable parameters, must be used and are as listed in row (1+2) for each barrier.
- Not suitable for voltage signals or resistive sensors
- Maximum leakage current at 24 V < 1 mA
- Maximum leakage current at 35 V < 10 mA

FM / UL Information – Ex Interface to Class I, II, III, Division 1 or Class I, Zone 0													
Product Type	Operational Characteristics				Entity Parameters			Gas Group Cable Parameters				Art. No.	
	Channel	V_{nom}	R_{min}	R_{max}	I_{max}	U_o/V_{oc}	I_o/I_{sc}	P_o	L_o/L_c for A, B, E or IIC	C_o/C_c for A, B, E or IIC	L_o/L_c for C, D, F, G or IIB, IIA		C_o/C_c for C, D, F, G or IIB, IIA
9002/13-252-121-041	1	20-35 V	217 Ω	244 Ω	86 mA	25.2 V	118 mA	0.74 mW	1.3 mH	0.107 μ F	7.4 mH	0.82 μ F	158830
	2	22 V				25.2 V	0 mA	0.02 mW	50 mH	0.107 μ F	150 mH	0.82 μ F	
	1 + 2					25.5 V	121 mA	0.76 mW	1.25 mH	0.104 μ F	7.35 mH	0.8 μ F	

08 b

CSA Information – Ex Interface to Class I, II, III, Division 1													
Product Type	Operational Characteristics				Entity Parameters			Gas Group Cable Parameters				Art. No.	
	Channel	V_{nom}	R_{min}	R_{max}	I_{max}	U_o/V_{oc}	I_o/I_{sc}	P_o	L_o/L_c for A, B, E	C_o/C_c for A, B, E	L_o/L_c for C, D, F, G		C_o/C_c for C, D, F, G
9002/13-252-121-041	1	20-35 V	220 Ω	244 Ω	86 mA	25.1 V	120.1 mA	0.74 W	2.5 mH	0.17 μ F	9.8 mH	0.51 μ F	158830
	2	22 V	Diode *			25.1 V	0 mA	0.02 W	1000 mH	0.17 μ F	1000 mH	0.51 μ F	
	1 + 2					25.9 V	120 mA	0.76 W	2.5 mH	0.104 μ F	9.8 mH	0.42 μ F	

CSA Information – Ex Interface to Class I, Zone 0													
Product Type	Operational Characteristics				Entity Parameters			Gas Group Cable Parameters				Art. No.	
	Channel	V_{nom}	R_{min}	R_{max}	I_{max}	U_o/V_{oc}	I_o/I_{sc}	P_o	L_o/L_c for IIC	C_o/C_c for IIC	L_o/L_c for IIA, IIB		C_o/C_c for IIA, IIB
9002/13-252-121-041	1	20-35 V	220 Ω	244 Ω	86 mA	25.2 V	118 mA	0.74 W	1.3 mH	0.107 μ F	7.4 mH	0.82 μ F	158830
	2	22 V	Diode *			25.2 V	0 mA	0.02 W	50 mH	0.107 μ F	150 mH	0.82 μ F	
	1 + 2					25.5 V	121 mA	0.76 W	1.25 mH	0.104 μ F	7.35 mH	0.8 μ F	

ATEX Information – Ex Interface to Zone 0													
Product Type	Operational Characteristics				Entity Parameters			Gas Group Cable Parameters				Art. No.	
	Channel	V_{nom}	R_{min}	R_{max}	I_{max}	U_o/V_{oc}	I_o/I_{sc}	P_o	L_o/L_c for IIC	C_o/C_c for IIC	L_o/L_c for IIB		C_o/C_c for IIB
9002/13-252-121-041	1	20-35 V	217 Ω	244 Ω	86 mA	25.2 V	118 mA	740 mW	1.3 mH	0.107 μ F	7.4 mH	0.82 μ F	158830
	2	22 V				25.2 V	0 mA	20 mW	50 mH	0.107 μ F	150 mH	0.82 μ F	
	1 + 2					25.5 V	121 mA	760 mW	1.25 mH	0.104 μ F	7.35 mH	0.8 μ F	

Diode*: designates diode return

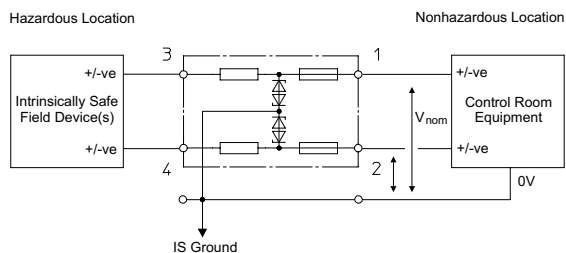

- Application specific for the connection of RTDs
- High resistance tolerance in each channel, $20 \Omega \pm 0.1$
- Low temperature coefficient $< 50 \text{ ppm/K}$
- Allows the connection of regulated power supplies, V_{nom}
- Approved for installation in hazardous areas (refer to certificate).

- When two channels of one barrier are connected together to one field device with no isolation between the channels, the resultant entity parameters, V_T , I_T , P_o , and cable parameters, must be used and are as listed in row (1+2) for each barrier.
- Maximum leakage $< 10 \text{ pA}$
- One channel required for each RTD leg.

FM / UL Information – Ex Interface to Class I, II, III, Division 1 or Class I, Zone 0

Product Type	Operational Characteristics				Entity Parameters			Gas Group Cable Parameters				Art. No.	
	Channel	V_{nom}	R_{min}	R_{max}	I_{max}	U_o/V_{oc}	I_o/I_{sc}	P_o	L_o/L_c for A, B, E or IIC	C_o/C_c for A, B, E or IIC	L_o/L_c for C, D, F, G or IIB, IIA		C_o/C_c for C, D, F, G or IIB, IIA
9002/22-032-300-111	1	0.7 V	21.6 Ω	23.8 Ω	33 mA	1.6 V	150 mA	0.06 mW	1.3 mH	100 μF	7 mH	1000 μF	158954
	2	0.7 V	21.6 Ω	23.8 Ω	33 mA	1.6 V	150 mA	0.06 mW	1.3 mH	100 μF	7 mH	1000 μF	
	1 + 2	1.4 V	-	-	-	3.2 V	300 mA	0.12 mW	0.2 mH	100 μF	1.8 mH	1000 μF	

CSA Information – Ex Interface to Class I, II, III, Division 1

Product Type	Operational Characteristics				Entity Parameters			Gas Group Cable Parameters				Art. No.	
	Channel	V_{nom}	R_{min}	R_{max}	I_{max}	U_o/V_{oc}	I_o/I_{sc}	P_o	L_o/L_c for A, B, E	C_o/C_c for A, B, E	L_o/L_c for C, D, F, G		C_o/C_c for C, D, F, G
9002/22-032-300-111	1	0.7 V	13 Ω	23.8 Ω	33 mA	1.6 V	150 mA	0.06 W	2.2 mH	1800 μF	8.7 mH	1800 μF	158954
	2	0.7 V	13 Ω	23.8 Ω	33 mA	1.6 V	150 mA	0.06 W	2.2 mH	1800 μF	8.7 mH	1800 μF	
	1 + 2	1.4 V	-	-	-	3.2 V	311 mA	0.12 W	0.26 mH	1800 μF	2.3 mH	1800 μF	

CSA Information – Ex Interface to Class I, Zone 0

Product Type	Operational Characteristics				Entity Parameters			Gas Group Cable Parameters				Art. No.	
	Channel	V_{nom}	R_{min}	R_{max}	I_{max}	U_o/V_{oc}	I_o/I_{sc}	P_o	L_o/L_c for IIC	C_o/C_c for IIC	L_o/L_c for IIA, IIB		C_o/C_c for IIA, IIB
9002/22-032-300-111	1	0.7 V	13 Ω	23.8 Ω	33 mA	1.6 V	150 mA	0.06 W	1.3 mH	100 μF	7 mH	1000 μF	158954
	2	0.7 V	13 Ω	23.8 Ω	33 mA	1.6 V	150 mA	0.06 W	1.3 mH	100 μF	7 mH	1000 μF	
	1 + 2	1.4 V	-	-	-	3.2 V	300 mA	0.12 W	0.2 mH	100 μF	1.8 mH	1000 μF	

ATEX Information – Ex Interface to Zone 0

Product Type	Operational Characteristics				Entity Parameters			Gas Group Cable Parameters				Art. No.	
	Channel	V_{nom}	R_{min}	R_{max}	I_{max}	U_o/V_{oc}	I_o/I_{sc}	P_o	L_o/L_c for IIC	C_o/C_c for IIC	L_o/L_c for IIB		C_o/C_c for IIB
9002/22-032-300-111	1	0.7 V	21.6 Ω	23.8 Ω	33 mA	1.6 V	150 mA	60 mW	1.3 mH	100 μF	7 mH	1000 μF	158954
	2	0.7 V	21.6 Ω	23.8 Ω	33 mA	1.6 V	150 mA	60 mW	1.3 mH	100 μF	7 mH	1000 μF	
	1 + 2	1.4 V	-	-	-	3.2 V	300 mA	120 mW	0.2 mH	100 μF	1.8 mH	1000 μF	

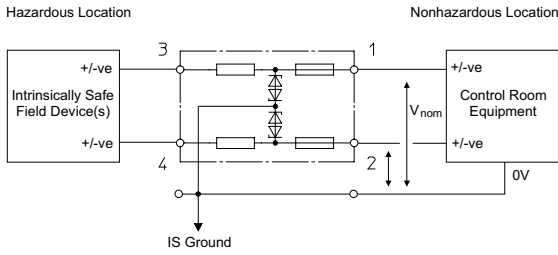

- Allows the connection of regulated power supplies, V_{nom} , as listed in the table below.
- Various safety and operational characteristics as listed in the table below
- Approved for installation in hazardous areas (refer to certificate).

- When two channels of one barrier are connected together to one field device with no isolation between the channels, the resultant entity parameters, V_T , I_T , P_o , and cable parameters, must be used and are as listed in row (1+2) for each barrier.

FM / UL Information – Ex Interface to Class I, II, III, Division 1 or Class I, Zone 0													
Product Type	Operational Characteristics					Entity Parameters			Gas Group Cable Parameters				Art. No.
	Channel	V_{nom}	R_{min}	R_{max}	I_{max}	U_o/V_{oc}	I_o/I_{sc}	P_o	L_o/L_s for A, B, E or IIC	C_o/C_s for A, B, E or IIC	L_o/L_s for C, D, F, G or IIB, IIA	C_o/C_s for C, D, F, G or IIB, IIA	
9002/22-158-200-001	1	5.5 V	84 Ω	95 Ω	57 mA	7.9 V	100 mA	0.198 mW	4 mH	8.8 μF	15 mH	115 μF	158952
	2	5.5 V	84 Ω	95 Ω	57 mA	7.9 V	100 mA	0.198 mW	4 mH	8.8 μF	15 mH	115 μF	
	1 + 2	11 V	-	-	-	15.8 V	200 mA	0.395 mW	0.5 mH	0.478 μF	4 mH	2.88 μF	
9002/22-240-024-001	1	9 V	1051 Ω	1164 Ω	7.7 mA	12 V	12 mA	0.04 mW	240 mH	1.41 μF	850 mH	9 μF	158950
	2	9 V	1051 Ω	1164 Ω	7.7 mA	12 V	12 mA	0.04 mW	240 mH	1.41 μF	850 mH	9 μF	
	1 + 2	18 V	-	-	-	24 V	24 mA	0.08 mW	41 mH	0.125 μF	145 mH	0.93 μF	
9002/22-240-160-001	1	9 V	158 Ω	177 Ω	50 mA	12 V	80 mA	0.24 mW	6 mH	1.41 μF	22 mH	9 μF	158948
	2	9 V	158 Ω	177 Ω	50 mA	12 V	80 mA	0.24 mW	6 mH	1.41 μF	22 mH	9 μF	
	1 + 2	18 V	-	-	-	24 V	160 mA	0.48 mW	0.7 mH	0.125 μF	4 mH	0.93 μF	

08 b

CSA Information – Ex Interface to Class I, II, III, Division 1													
Product Type	Operational Characteristics					Entity Parameters			Gas Group Cable Parameters				Art. No.
	Channel	V_{nom}	R_{min}	R_{max}	I_{max}	U_o/V_{oc}	I_o/I_{sc}	P_o	L_o/L_s for A, B, E	C_o/C_s for A, B, E	L_o/L_s for C, D, F, G	C_o/C_s for C, D, F, G	
9002/22-158-200-001	1	5.5 V	79 Ω	95 Ω	57 mA	7.9 V	100 mA	0.198 W	4 mH	8.8 μF	15 mH	115 μF	158952
	2	5.5 V	79 Ω	95 Ω	57 mA	7.9 V	100 mA	0.198 W	4 mH	8.8 μF	15 mH	115 μF	
	1 + 2	11 V	-	-	-	15.8 V	200 mA	0.395 W	0.5 mH	0.478 μF	4 mH	2.88 μF	
9002/22-240-024-001	1	9 V	1020 Ω	1164 Ω	7.7 mA	11.3 V	11.4 mA	0.04 W	258 mH	2 μF	899 mH	6 μF	158950
	2	9 V	1020 Ω	1164 Ω	7.7 mA	11.3 V	1.9 mA	0.04 W	258 mH	2 μF	899 mH	6 μF	
	1 + 2	18 V	-	-	-	22.6 V	23 mA	0.08 W	67 mH	0.23 μF	236 mH	0.7 μF	
9002/22-240-160-001	1	9 V	160 Ω	177 Ω	50 mA	11.3 V	76 mA	0.24 W	6.5 mH	2 μF	25 mH	6 μF	158948
	2	9 V	160 Ω	177 Ω	50 mA	11.3 V	1.9 mA	0.24 W	6.5 mH	2 μF	25 mH	6 μF	
	1 + 2	18 V	-	-	-	22.6 V	152 mA	0.48 W	1.2 mH	0.23 μF	7.1 mH	0.7 μF	

CSA Information – Ex Interface to Class I, Zone 0													
Product Type	Operational Characteristics					Entity Parameters			Gas Group Cable Parameters				Art. No.
	Channel	V_{nom}	R_{min}	R_{max}	I_{max}	U_o/V_{oc}	I_o/I_{sc}	P_o	L_o/L_s for IIC	C_o/C_s for IIC	L_o/L_s for IIA, IIB	C_o/C_s for IIA, IIB	
9002/22-158-200-001	1	5.5 V	79 Ω	95 Ω	57 mA	7.9 V	100 mA	0.198 W	4 mH	8.8 μF	15 mH	115 μF	158952
	2	5.5 V	79 Ω	95 Ω	57 mA	7.9 V	100 mA	0.198 W	4 mH	8.8 μF	15 mH	115 μF	
	1 + 2	11 V	-	-	-	15.8 V	200 mA	0.395 W	0.5 mH	0.478 μF	4 mH	2.88 μF	
9002/22-240-024-001	1	9 V	1020 Ω	1164 Ω	7.7 mA	12 V	12 mA	0.04 W	240 mH	1.41 μF	850 mH	9 μF	158950
	2	9 V	1020 Ω	1164 Ω	7.7 mA	12 V	12 mA	0.04 W	240 mH	1.41 μF	850 mH	9 μF	
	1 + 2	18 V	-	-	-	24 V	24 mA	0.08 W	41 mH	0.125 μF	145 mH	0.93 μF	
9002/22-240-160-001	1	9 V	160 Ω	177 Ω	50 mA	12 V	80 mA	0.24 W	6 mH	1.41 μF	22 mH	9 μF	158948
	2	9 V	160 Ω	177 Ω	50 mA	12 V	80 mA	0.24 W	6 mH	1.41 μF	22 mH	9 μF	
	1 + 2	18 V	-	-	-	24 V	160 mA	0.48 W	0.7 mH	0.125 μF	4 mH	0.93 μF	

ATEX Information – Ex Interface to Zone 0													
Product Type	Operational Characteristics					Entity Parameters			Gas Group Cable Parameters				Art. No.
	Channel	V _{nom}	R _{min}	R _{max}	I _{max}	U ₀ /V _{oc}	I ₀ /I _{sc}	P ₀	L _l /L _s for IIC	C _l /C _s for IIC	L _l /L _s for IIB	C _l /C _s for IIB	
9002/22-158-200-001	1	5.5 V	84 Ω	95 Ω	57 mA	7.9 V	100 mA	198 mW	4 mH	8.8 μF	15 mH	115 μF	158952
	2	5.5 V	84 Ω	95 Ω	57 mA	7.9 V	100 mA	198 mW	4 mH	8.8 μF	15 mH	115 μF	
	1 + 2	11 V				15.8 V	200 mA	395 mW	0.5 mH	0.478 μF	4 mH	2.88 μF	
9002/22-240-024-001	1	9 V	1051 Ω	1164 Ω	7.7 mA	12 V	12 mA	40 mW	240 mH	1.41 μF	850 mH	9 μF	158950
	2	9 V	1051 Ω	1164 Ω	7.7 mA	12 V	12 mA	40 mW	240 mH	1.41 μF	850 mH	9 μF	
	1 + 2	18 V				24 V	24 mA	80 mW	41 mH	0.125 μF	145 mH	0.93 μF	
9002/22-240-160-001	1	9 V	158 Ω	177 Ω	50 mA	12 V	80 mA	240 mW	6 mH	1.41 μF	22 mH	9 μF	158948
	2	9 V	158 Ω	177 Ω	50 mA	12 V	80 mA	240 mW	6 mH	1.41 μF	22 mH	9 μF	
	1 + 2	18 V				24 V	160 mA	480 mW	0.7 mH	0.125 μF	4 mH	0.93 μF	

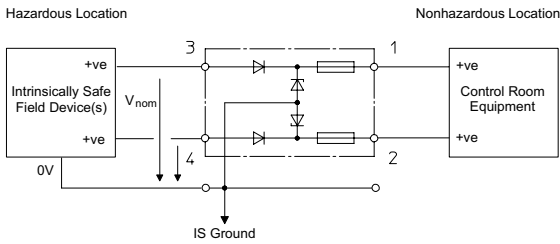

- Diode return barrier for DC current return signals with very small entity current (I_{sc}) addition
- Suitable for dry contact and floating 4/20 mA signal returns
- Both channels are positive polarity.
- Approved for installation in hazardous areas (refer to certificate).

- When two channels of one barrier are connected together to one field device with no isolation between the channels, the resultant entity parameters, V_T , I_T , P_O , and cable parameters, must be used and are as listed in row (1+2) for each barrier.
- Not suitable for voltage signals or resistive sensors
- Voltage drop $\Delta V = 2.5 V$ at $I < 20 mA$, $\Delta V = 3.5 V$ at $I > 20 mA$

FM / UL Information – Ex Interface to Class I, II, III, Division 1 or Class I, Zone 0											
Product Type	Operational Characteristics			Entity Parameters			Gas Group Cable Parameters				Art. No.
	Channel	V_{nom}	I_{max}	U_0/V_{oc}	I_0/I_{sc}	P_o	L_f/L_g for A, B, E or IIC	C_f/C_g for A,B,E or IIC	L_f/L_g for C, D, F, G or IIB, IIA	C_f/C_g for C, D, F, G or IIB, IIA	
9002/33-280-000-001	1	25.5 V	60 mA	28 V	0 mA	0 mW	1000 mH	0.083 μF	1000 mH	0.65 μF	158913
	2	25.5 V	60 mA	28 V	0 mA	0 mW	1000 mH	0.083 μF	1000 mH	0.65 μF	
	1 + 2			28 V	0 mA	0 mW	1000 mH	0.083 μF	1000 mH	0.65 μF	



08 b

CSA Information – Ex Interface to Class I, II, III, Division 1												
Product Type	Operational Characteristics			Entity Parameters			Gas Group Cable Parameters				Art. No.	
	Channel	V_{nom}	R_{min}	I_{max}	U_0/V_{oc}	I_0/I_{sc}	P_o	L_f/L_g for A, B, E	C_f/C_g for A, B, E	L_f/L_g for C, D, F, G		C_f/C_g for C, D, F, G
9002/33-280-000-001	1	25.5 V	Diode *	60 mA	28 V	0 mA	0 W	1000 mH	0.14 μF	1000 mH	0.43 μF	158913
	2	25.5 V	Diode *	60 mA	28 V	0 mA	0 W	1000 mH	0.14 μF	1000 mH	0.43 μF	
	1 + 2		-		28.5 V	0 mA	0 W	1000 mH	0.14 μF	1000 mH	0.4 μF	

CSA Information – Ex Interface to Class I, Zone 0												
Product Type	Operational Characteristics			Entity Parameters			Gas Group Cable Parameters				Art. No.	
	Channel	V_{nom}	R_{min}	I_{max}	U_0/V_{oc}	I_0/I_{sc}	P_o	L_f/L_g for IIC	C_f/C_g for IIC	L_f/L_g for IIA, IIB		C_f/C_g for IIA, IIB
9002/33-280-000-001	1	25.5 V	Diode *	60 mA	28 V	0 mA	0 W	1000 mH	0.083 μF	1000 mH	0.65 μF	158913
	2	25.5 V	Diode *	60 mA	28 V	0 mA	0 W	1000 mH	0.083 μF	1000 mH	0.65 μF	
	1 + 2		-		28 V	0 mA	0 W	1000 mH	0.083 μF	1000 mH	0.65 μF	

ATEX Information – Ex Interface to Zone 0													
Product Type	Operational Characteristics			Entity Parameters			Gas Group Cable Parameters				Art. No.		
	Channel	V_{nom}	R_{min}	R_{max}	I_{max}	U_0/V_{oc}	I_0/I_{sc}	P_o	L_f/L_g for IIC	C_f/C_g for IIC		L_f/L_g for IIB	C_f/C_g for IIB
9002/33-280-000-001	1	25.5 V	0	0	60 mA	28 V	0 mA	0	1000 mH	0.083 μF	1000 mH	0.65 μF	158913
	2	25.5 V			60 mA	28 V	0 mA	0	1000 mH	0.083 μF	1000 mH	0.65 μF	
	1 + 2					28 V	0 mA	0	1000 mH	0.083 μF	1000 mH	0.65 μF	

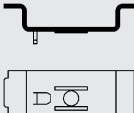
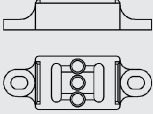
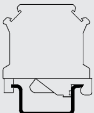
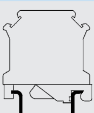
Accessories

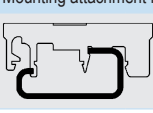
Figure	Description	Product Type	Art. No.	Weight lb
Adaptor				
	Adaptor allows installation of a zener barrier Series 900x on a mounting plate of a previous series.	-	158826	0.01 lb
Insulating stand off				
	Suitable for DIN rail NS35/15, allows electrically insulated mounting of DIN rail from mounting plate.	-	158828	0.05 lb
Protective conductor terminal				
	USLKG 5 (wire range AWG 12 / 4 mm ²) Terminal enables connection of protective conductors to DIN rail. Color green-yellow.	USLKG5 GNYE	112760	0.03 lb
Ground terminal				
	USLKG 6 N (wire range AWG 10 / 6 mm ²) Terminal enables connection of protective /Ground conductors to DIN rail. Color green-yellow.	USLKG6 N GNYE	112599	0.07 lb
Fuse holder				
	Fuse holder is snapped onto the side of the zener barrier and can be equipped with up to 5 back-up fuses (replacement).	-	158834	0.04 lb
Mounting attachment moulded plastic				
	Enables mounting of zener barrier on a G-rail.	-	165283	0.01 lb

Spare Parts

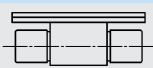
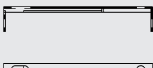
Figure	Description	Art. No.	Weight lb
Back-up fuse			
	For all zener barriers Series 9001, 9002 and 9004 unit: 5 pcs.	158964	0.02 lb
Holder for label			
	Transparent cover for labelling	158977	0 lb

Dimensional Drawings (All Dimensions in mm [inches]) – Subject to Alterations

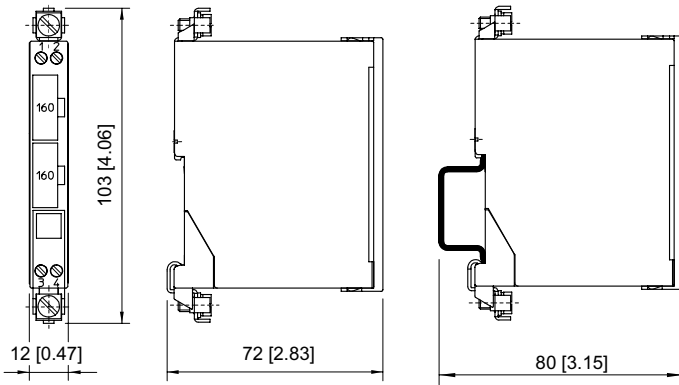

Mounting on DIN rail NS 35/15

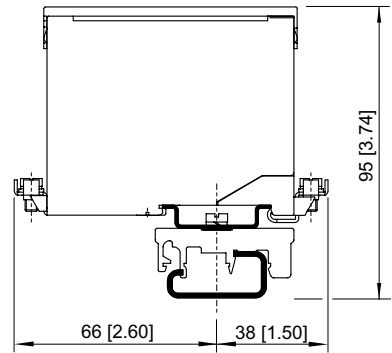

Mounting on DIN rail NS 32 by means of adaptor and mounting attachment, moulded plastic

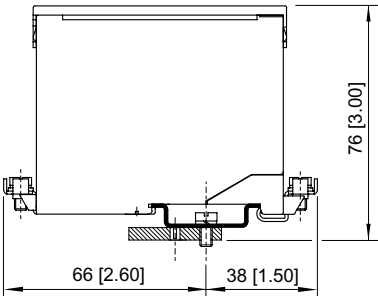

Mounting on mounting plate by means of adaptor

08 b

FOUNDATION FIELDBUS COMPONENTS

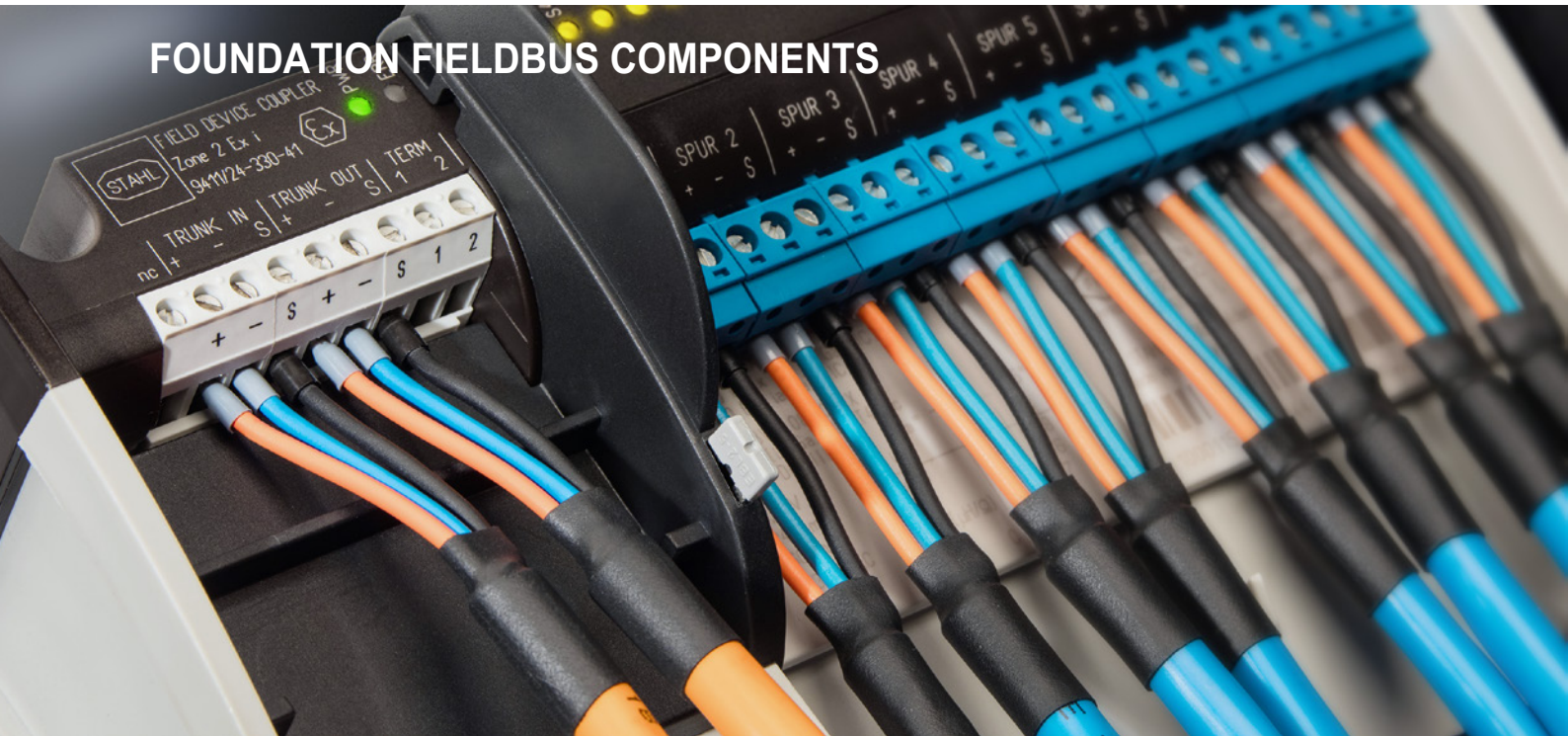

Product	Series	Page	WebCode
bus-Carrier			
bus-Carrier	9419	275	9419A
Diagnosis Communication Module			
Diagnosis Communication Module	9415	272	9415A
Fieldbus Power Supply			
Fieldbus Power Supply	9412	269	9412A
Fieldbus Terminator			
Fieldbus Terminator	9418	287	9418A
Field Device Coupler			
Ex i Field Device Coupler 4 Spurs	9411/21	277	9411C
Ex i Field Device Coupler 4 Spurs	9411/24	281	9411E
Ex i Field Device Coupler 8 Spurs	9411/21	279	9411D
Ex i Field Device Coupler 8 Spurs	9411/24	283	9411F
Ex n Field Device Coupler	9410	285	9410A
General			
General		268	
Overview			
Overview of Functions ISbus		267	
Overview of System Components		267	

For additional products and information please refer to r-stahl.com

Overview of the System Components

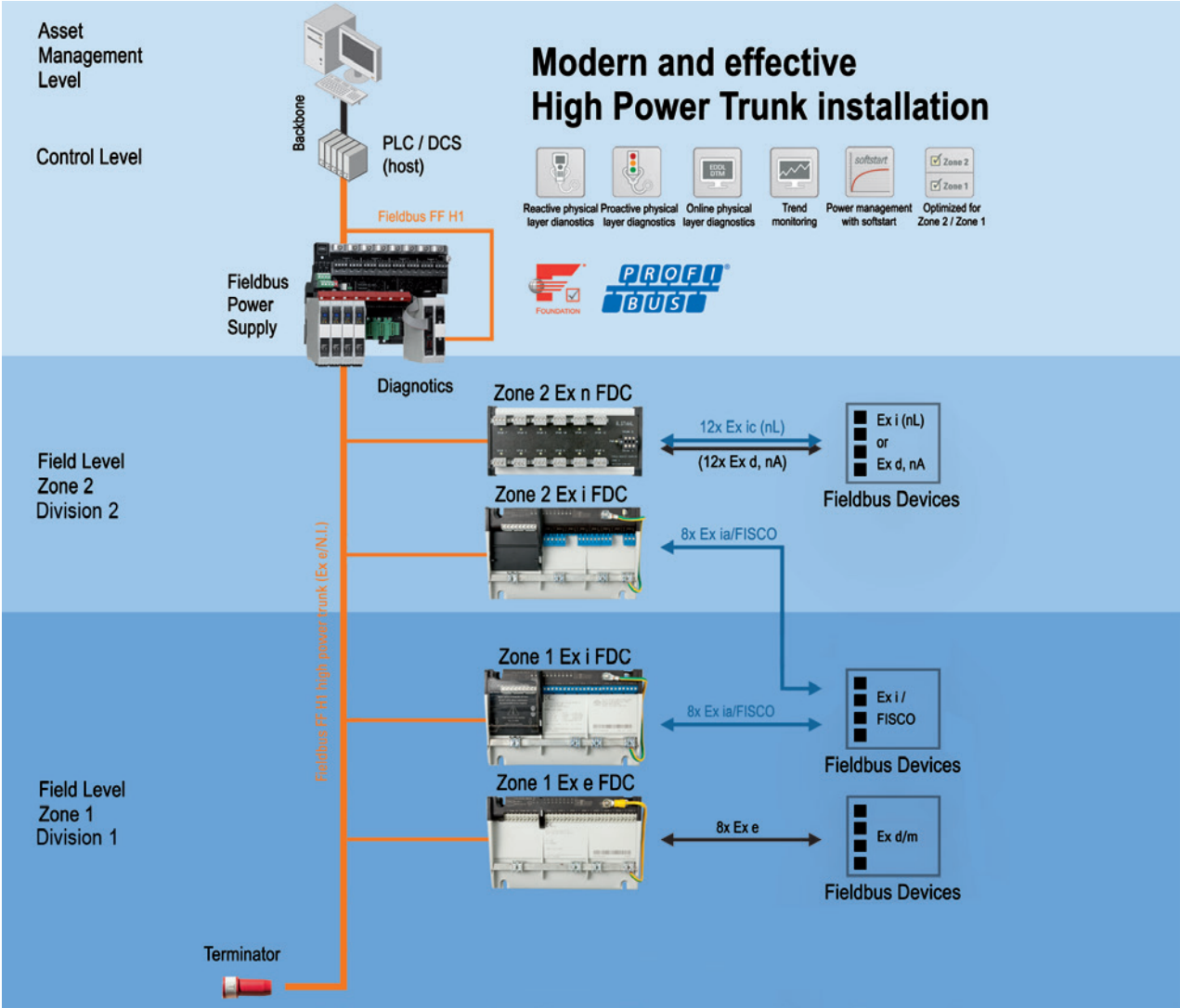

09

Overview of Functions ISbus

		Field device coupler		
		9410/34	9411/24	9411/21
Field device	Installation	Cl. I, Div. 2, Zone 2	Cl. I, Div. 2, Zone 2	Cl. I, Div. 2, Zone 1
FISCO/Entity (ia, ib)	Cl. I, Div. 2, Zone 0/1		x	x
	Cl. I, Div. 2, Zone 2		x	
FISCO/Entity (ic)	Cl. I, Div. 2, Zone 2	x ¹⁾	x	
Ex ic (entity)	Cl. I, Div. 2, Zone 2	x ¹⁾	x	
Ex d/q/m	Cl. I, Div. 2, Zone 2	x		
	Cl. I, Div. 2, Zone 2	x		
Ex nA	Cl. I, Div. 2, Zone 2	x		
Ex i solenoid valve	Cl. I, Div. 2, Zone 0/1			
Ex i contact	Cl. I, Div. 2, Zone 0/1			

¹⁾ Fieldbus power supply with Ex ic parameters suitable for field device required

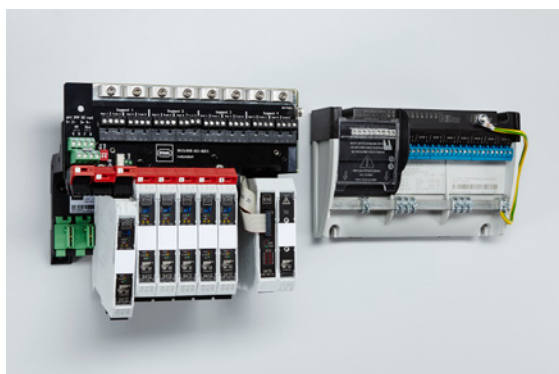

- Components and systems for use on Profibus PA and FOUNDATION™ fieldbus H1 systems
- Full product range for fieldbus installations based on the “High Power Trunk” concept in Zone 1, Zone 2 and Class I, Div. 2
- Integration of simple, discrete signals onto the fieldbus
- Redundant fieldbus power supply with galvanic isolation for FOUNDATION™ fieldbus H1
- Advanced physical layer diagnostics, optional integrated into fieldbus power supply or via H1 network
- Field housings of different sizes and materials, such as plastic, stainless steel and aluminium



Fieldbus technology has become established in recent years alongside conventional field devices and field devices with HART support. The solutions from the Profibus Organisation or the FieldComm Group are now used in the majority of new installations. Solutions with fieldbus barriers have largely replaced pure FISCO installations. The R. STAHL product range includes field device couplers for installation in Zone 1, Zone 2 and Class I, Div. 2 for connection of e.g. I.S. or FISCO and non I.S. fieldbus devices. The bus is supplied with the necessary power using a simplex or redundant power supply. Physical Layer Diagnostics is integrated as standard in the fieldbus power supply and can also be transmitted via FF H1 on asset management systems.

09

Besides the new ISbus components for FOUNDATION™ fieldbus and Profibus PA, R. STAHL also supplies all-inclusive system solutions. These range from different types of field housings, made from plastic, stainless steel, or aluminium, and innovative solutions with Ex-plug connectors for the non-intrinsically safe fieldbus to complete system solutions for all different forms of field signals. Depending on the application and customer requirements, R. STAHL optimally combines the components and systems from the Fieldbus ISbus and Remote I/O IS1+ sectors to create the most efficient and low-cost solution.



- For single or redundant power supply to FOUNDATION Fieldbus H1 segments (High Power Trunk)
- Output > 28 V, up to 1 A, galvanically separated
- Integrated advanced physical layer diagnostics

WebCode **9412A**



Single or redundant 9412 series fieldbus power supplies are used to supply an FF H1 High Power Trunk with up to 28 V/500 mA, and up to 1 A in Boost mode. In the background, they measure the advanced physical layer parameters, which can be reported via an Android smartphone, configurable integrated alarms or online via FF H1. 9419 series bus carriers or DIN rails can be used for installation.

	NEC® 500 CEC Appendix J					
	Class I		Class II		Class III	
Division	1	2	1	2	1	2
Ex interface						
Installation in		•		•		•

	CEC Section 18 NEC® 505 NEC® 506					
	Class I					
Zone	0	1	2	20	21	22
Ex interface						
Installation in			•			•

	IECEx / ATEX					
	Zone	0	1	2	20	21
Ex interface						
Installation in			•			•



09

Selection Table				
Product variant	Fieldbus Power Supply			
Description	Error message	Product Type	Art. No.	Weight lb
Fieldbus power supply and diagnostics	Overload and short circuit	9412/00-310-11s	200586	0.3
Fieldbus power supply, diagnostics and adjustable warning level	Overload, short circuit and Physical Layer values: trunk voltage/current, signal level, noise, jitter, unbalance	9412/00-320-11s	200588	0.3

Technical Data		
Variant	9412/00-310-11s	9412/00-320-11s
Explosion Protection		
USA certificate FM	3026646	
CAN certificate FM	3026646C	
USA marking FM	Class I, Zone 2, AEx nA nC IIC T4; Ta=70°C NI, Class I, Div. 2, Groups A, B, C, D, T4; Ta=70°C See Doc. 9412 6 031 001 1	
CAN marking FM	Class I, Zone 2, Ex nA nC IIC T4; Ta=70°C NI, Class I, Div. 2, Groups A, B, C, D, T4; Ta=70°C See Doc. 9412 6 031 001 1	
IECEx gas explosion protection	Ex nA nC IIC T4 Gc	Ex nA nC IIC T4 Gc
Certificates	ATEX (BVS), Brazil (ULB), Canada (FM), EAC (Sertium), IECEx (BVS), India (PESO), International (FF), USA (FM)	ATEX (BVS), Brazil (ULB), EAC (Sertium), IECEx (BVS), India (PESO), International (FF)
Electrical Data		
Segment supply U _s	≥ 28 V DC	≥ 28 V DC

Technical Data		
Variant	9412/00-310-11s	9412/00-320-11s
Electrical Data		
Segment supply U_s note	Other voltage variant for ic-FISCO and entity on request	Other voltage variant for ic-FISCO and entity on request
Segment supply I_s	500 mA	500 mA
Segment supply I_s note	Up to 1 A in boost mode	Up to 1 A in boost mode
Fieldbus specification	IEC 61158-2, FOUNDATION™ fieldbus H1 FF-831	IEC 61158-2, FOUNDATION™ fieldbus H1 FF-831
Auxiliary Power		
Nominal voltage V_{nom}	24 V DC	24 V DC
Max. power consumption	2.8 W	2.8 W
Power dissipation max.	2.75 W	2.75 W
Max. power dissipation note	at 500 mA output current and 24 V auxiliary power	at 500 mA output current and 24 V auxiliary power
Output		
Error messaging device	Relay contact (30 V DC/100 mA),	Relay contact (30 V DC/100 mA),
Ambient Conditions		
Ambient temperature °F	-4°F ... +158°F	-4°F ... +158°F
Ambient temperature °C	-20 °C ... +70 °C	-20 °C ... +70 °C

Accessories

Figure	Description	Product Type	Art. No.	Weight lb
bus-Carrier				
	bus-Carrier for 4 segments, redundant	9419/04R-XX1-02C1	208746	1.32
	bus-Carrier for 8 segments, simplex	9419/08F-XX1-01C1	208745	1.32
	bus-Carrier for 8 segments, redundant	9419/08R-XX1-02C1	208747 ▲	2.65
bus-Carrier for Linking Device				
	bus-Carrier for Linking Device for 4 segments, simplex	9419/04F-LD1-01E1	250240	1.57
	bus-Carrier for Linking Device for 4 segments, redundant	9419/04R-LD1-02E1	250241 ▲	2.16
	bus-Carrier for Linking Device for 8 segments, simplex	9419/08F-LD1-01E1	250242	2.23

Dimensional Drawings (All Dimensions in mm [inches]) – Subject to Alterations

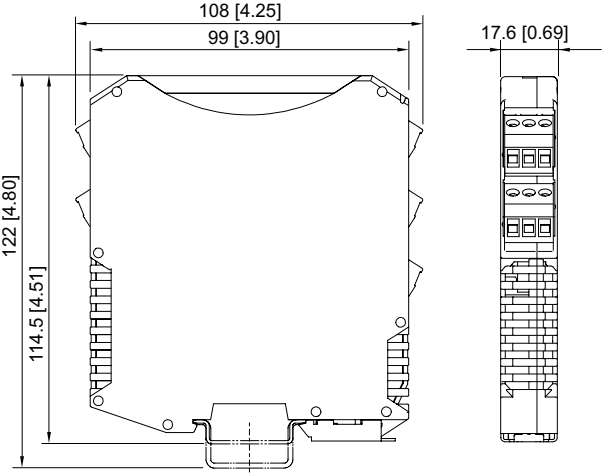

ISpac Series 9146, 9147, 9160, 9162, 9163, 9165, 9167, 9170, 9172, 9175, 9176, 9180, 9182, 9193 with screw terminal



- Physical layer diagnostics for up to eight FOUNDATION™ fieldbus H1 segments transmitted via an H1 network of your choice
- Diagnostics for voltage/current, jitter, noise, signal level, imbalance
- DTM and EDD with numerous alarm setting options, access to maintenance information, detailed reporting

WebCode 9415A



The 9415 series diagnostic communication module (DCM) transmits the physical layer diagnostics data that is measured continuously by the 9412 series fieldbus power supplies for up to eight FF H1 segments to hosts or asset management systems. EDD and DTM are also available for integration. The data is logged in accordance with NAMUR NE 123 and processed in accordance with NAMUR NE 107 and FF-912. 9419 series bus carriers can be used for installation.

09

	NEC® 500 CEC Appendix J					
	Class I		Class II		Class III	
Division	1	2	1	2	1	2
Ex interface		•		•		•
Installation in		•				

	CEC Section 18					
	NEC® 505 Class I			NEC® 506		
Zone	0	1	2	20	21	22
Ex interface			•			
Installation in			•			

	IECEX / ATEX					
	Zone	0	1	2	20	21
Ex interface			•			
Installation in			•			

Selection Table





Product Description	ISbus fieldbus technology Diagnostics communication module	Art. No.	Weight lb
Description	Product Type		
Transmission of diagnostics data for up to 8 segments via FF H1	9415/00-310-42	207903	0.53

Installation in bus-carriers with 8 (simplex / redundant) or 16 (redundant) slots.

Technical Data

Explosion Protection	
USA certificate FM	3026646
CAN certificate FM	3026646C
USA marking FM	NI, Class I, Div. 2, Groups A,B,C,D; Class I, Zone 2, AEx nA [ic] IIC, T4; Ta = 70 °C; See Doc. 9415 6 031 001 1; ANI, Class I,II,III, Div. 2, Groups A,B,C,D,E,F,G
CAN marking FM	NI, Class I, Div. 2, Groups A,B,C,D; Class I, Zone 2, Ex nA [ic] IIC, T4; Ta = 70 °C; See Doc. 9415 6 031 001 1; ANI, Class I,II,III, Div. 2, Groups A,B,C,D,E,F,G
IECEX gas explosion protection	Ex nA [ic] IIC T4 Gc
Certificates	ATEX (BVS), Brazil (ULB), Canada (FM), EAC (Sertium), IECEX (BVS), International (FF), USA (FM)
Auxiliary Power	
Auxiliary power	Over bus carrier series 9419
Input	
Physical Layer Diagnostics	via Fieldbus Power Supplies 9412

Technical Data	
Input	
Physical Layer values	acc. to NAMUR NE 123
Physical Layer values fieldbus	Jitter, signal level
Physical Layer values segment	Jitter, signal level, noise, unbalanced loads, voltage, current
Device Specific Data	
Cyclic data transmission	10 DI function blocks for status information / common error per segment
Acyclic data transmission	9 Transducer blocks for detailed information: physical layer values, HI-alarm, HIHI-alarm, LO-alarm, LOLO-alarm, status DCM, status segment, status fieldbus devices
Ambient Conditions	
Ambient temperature °F	-4°F ... +158°F
Ambient temperature °C	-20 °C ... +70 °C

Accessories				
Figure	Description	Product Type	Art. No.	Weight lb
Fieldbus Power Supply				
	Fieldbus power supply and diagnostics	9412/00-310-11s	200586	0.3
bus-Carrier				
	bus-Carrier for 4 segments, redundant	9419/04R-XX1-02C1	208746	1.32
	bus-Carrier for 8 segments, simplex	9419/08F-XX1-01C1	208745	1.32
	bus-Carrier for 8 segments, redundant	9419/08R-XX1-02C1	208747 ▲	2.65
bus-Carrier for Linking Device				
	bus-Carrier for Linking Device for 4 segments, redundant	9419/04R-LD1-02E1	250241 ▲	2.16
	bus-Carrier for Linking Device for 4 segments, simplex	9419/04F-LD1-01E1	250240	1.57
	bus-Carrier for Linking Device for 8 segments, simplex	9419/08F-LD1-01E1	250242	2.23

09

Technical Drawings – Subject to Alterations

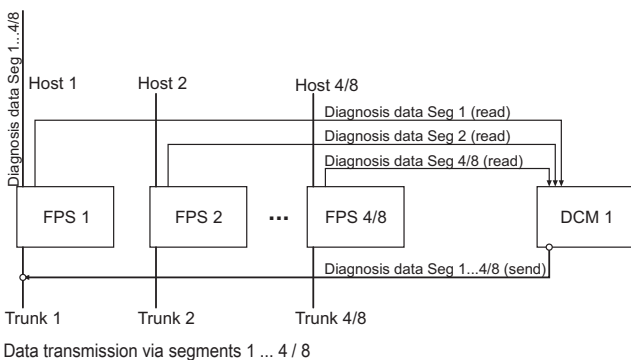

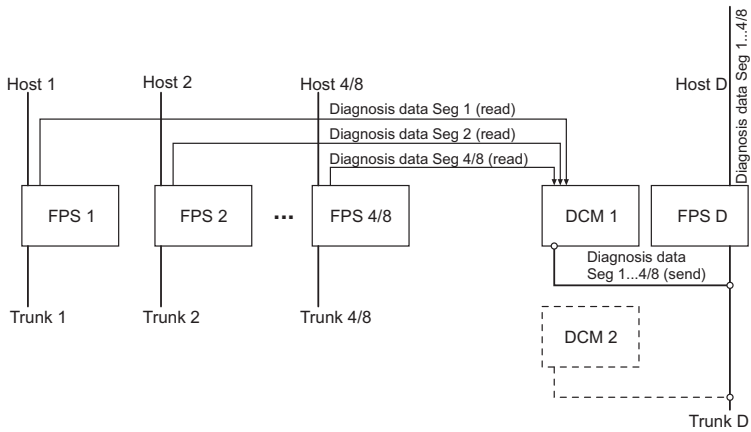

Data transmission via diagnosis segment (optional)

Dimensional Drawings (All Dimensions in mm [inches]) – Subject to Alterations

09

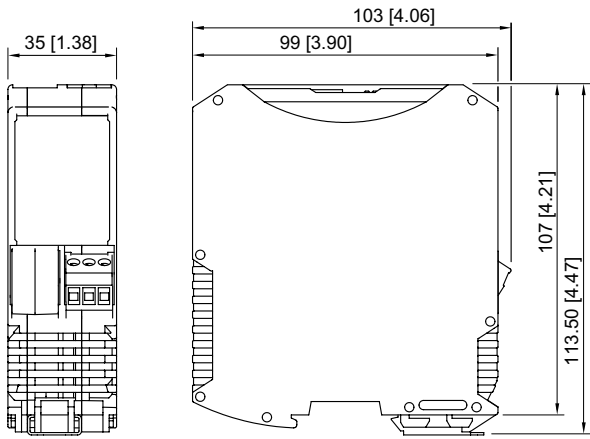

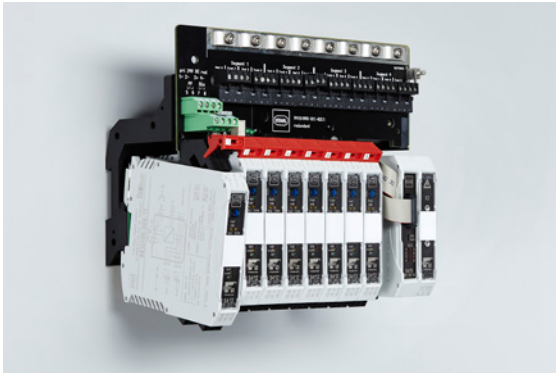

- Time- and cost-saving installation on DIN rails or mounting plates
- High availability thanks to redundant auxiliary power supply with signalling contact and separate signalling contact for segment errors
- Special slot for 9415 series DCM for online transmission of physical layer diagnostics

WebCode 9419A

9419 series bus carriers allow 9412 series fieldbus power supplies for FF H1 segments to be installed quickly and securely. Variants are available for eight segments with simplex supply and for four or eight segments with redundant supply. Pluggable terminals are used to connect the fieldbus segments and host assemblies.

	NEC® 500 CEC Appendix J					
	Class I		Class II		Class III	
Division	1	2	1	2	1	2
Ex interface						
Installation in		•		•		•

	CEC Section 18					
	NEC® 505 Class I			NEC® 506		
Zone	0	1	2	20	21	22
Ex interface						
Installation in			•			

	IECEX / ATEX					
	Zone	0	1	2	20	21
Ex interface						
Installation in			•			

09

Selection Table						
Product Description	ISbus fieldbus technology Bus-Carrier					
Connection	Trunk supply	Number of segments	Number of slots	Product Type	Art. No.	Weight lb
To any FF H1 host	Redundant	8	16 FPS + 1 DCM	9419/08R-XX1-02C1	208747	2.65

The shield terminals (see accessories) must be ordered separately for the bus-carrier.

Please order fieldbus power supplies (FPS) and diagnosis communication module (DCM) separately.

Technical Data	
Explosion Protection	
USA certificate FM	3026646
CAN certificate FM	3026646C
USA marking FM	NE, Class I, Div. 2, Groups A,B,C,D; Class I, Zone 2, AEx nA Nc IIC, T4; Ta = 70 °C; See Doc. 9415 6 031 001 1
CAN marking FM	NE, Class I, Div. 2, Groups A,B,C,D; Class I, Zone 2, Ex nA Nc IIC, T4; Ta = 70 °C; See Doc. 9415 6 031 001 1
IECEX gas explosion protection	Ex nA nC IIC T4 Gc
Certificates	ATEX (BVS), Brazil (ULB), Canada (FM), EAC (Sertium), IECEX (BVS), India (PESO), USA (FM)
Electrical Data	
Error detection Power Fail (pri / red)	Contact "PF" (35 V /100 mA) closed in good conditions
Error detection Diagnostic	Contact "Dia" (35 V /100 mA) closed in good conditions
Auxiliary Power	
Nominal voltage V _{nom}	24 V DC
Redundant supply	yes, diode-decoupled



Technical Data

Ambient Conditions	
Ambient temperature °F	-4°F ... +158°F
Ambient temperature °C	-20 °C ... +70 °C

Mechanical Data

Connection Trunk	to the terminals of the bus-Carrier or of the fieldbus power supply
Connection Host / red. host	to the terminals of the bus-Carrier or of the Fieldbus Power Supplies
Connection DCM	via ribbon cable using plug connectors
Connection shield	via integrated shield bar with strain relief

Accessories

Figure	Description	Product Type	Art. No.	Weight lb
Diagnosis Communication Module 9415				
	Transmission of diagnostics data for up to 8 segments via FF H1	9415/00-310-42	207903	0.53
Fieldbus Power Supply				
	Fieldbus power supply, diagnostics and adjustable warning level	9412/00-320-11s	200588 ▲	0.3
Spring-loaded clamping bracket				
	Spring-loaded clamping bracket KLBÜ C01	-	113509	-

Dimensional Drawings (All Dimensions in mm [inches]) – Subject to Alterations

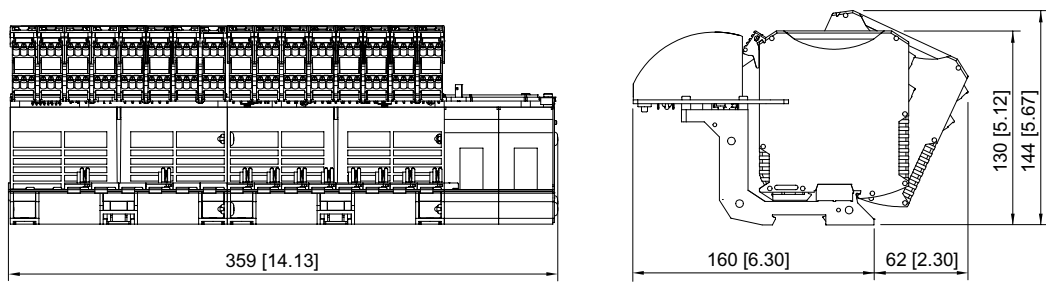



- For connecting four intrinsically safe (FISCO/Entity) fieldbus devices in Zone 1 and Class I, Div. 1
- Operated using High Power Trunk concept
- Reduced start-up current thanks to power management and short-circuit limiting with disconnection

WebCode 9411C



9411/21 series Ex i field device couplers for installation in Zone 1 and Class I, Div. 2 with galvanic separation can be used for interference-free connection of four FF H1 or PROFIBUS PA field devices on the High Power Trunk. The spurs with type of protection “ia” can be used for fieldbus devices in Zone 1 and Class I, Div. 1 (FISCO, Entity) and are protected by a short-circuit limiting function. The integrated power management minimises start-up and short-circuit currents. Available with screw terminals or spring clamp terminals.

09

	NEC® 500 CEC Appendix J					
	Class I		Class II		Class III	
Division	1	2	1	2	1	2
Ex interface	•	•	•	•	•	•
Installation in		•		•		•

	CEC Section 18 NEC® 505 NEC® 506					
	Class I					
Zone	0	1	2	20	21	22
Ex interface	•	•	•	•	•	•
Installation in		•	•		•	•

	IECEX / ATEX					
	Zone	0	1	2	20	21
Ex interface	•	•	•	•	•	•
Installation in		•	•		•	•



Selection Table					
Product Description	ISbus fieldbus technology Field device coupler				
Number of channels	Connection type	Product Type	Art. No.	Weight lb	
4	Screw terminal, detachable	9411/21-230-31	206826	1.92	
Field enclosures in polyester or stainless steel: customer specific solutions on request					

Technical Data	
Explosion Protection	
USA certificate FM	3026646
CAN certificate FM	3026646C
USA marking FM	NI, Class I, Div. 2, Groups A,B,C,D; AIS, Class I,II,III, Div. 1, Groups A,B,C,D,E,F,G; Class I, Zone 1, AEx m e [ia] IIC; T4 at Ta = 75 °C; See Doc. 9411 6 031 001 1
CAN marking FM	NI, Class I, Div. 2, Groups A,B,C,D; AIS, Class I,II,III, Div. 1, Groups A,B,C,D,E,F,G; Class I, Zone 1, Ex m e [ia] IIC; T4 at Ta = 75 °C; See Doc. 9411 6 031 001 1
IECEX gas explosion protection	Ex mb e ib [ia Ga] IIC T4 Gb
IECEX dust explosion protection	[Ex ia Da] IIIC
Certificates	ATEX (BVS), Brazil (ULB), Canada (FM), EAC (Sertium), IECEX (BVS), India (PESO), International (FF), USA (FM)
Auxiliary Power	
Power dissipation max.	1.8 W

Technical Data

Auxiliary Power	
Notes	Auxiliary power is not necessary, the field device coupler will be supplied by the trunk
Input	
Voltage range Trunk	16 – 32 V
Output	
Output current	0 mA ... 41 mA; per spur
Output voltage	Min. 10 V at 41 mA
Ambient Conditions	
Ambient temperature °F	-40°F ... +167°F
Ambient temperature °C	-40 °C ... +75 °C
Mechanical Data	
Field enclosure	Without, DIN rail mounting

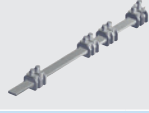
Accessories

Figure	Description	Product Type	Art. No.	Weight lb
Grounding bar set for 4 Spurs				
	Grounding bar 9411 spring terminal strap with 6 terminals	-	202774 ▲	0.28
	Grounding bar 9411 screw terminals	-	161929 ▲	0.18
Fieldbus Power Supply				
	Fieldbus power supply and diagnostics	9412/00-310-11s	200586	0.3
Fieldbus Wizard Engineering Tool				
	Engineering tool for segment design of Foundation Fieldbus or Profibus PA fieldbus installations Download under www.fieldbus-solutions.info	-	-	-

Dimensional Drawings (All Dimensions in mm [inches]) – Subject to Alterations

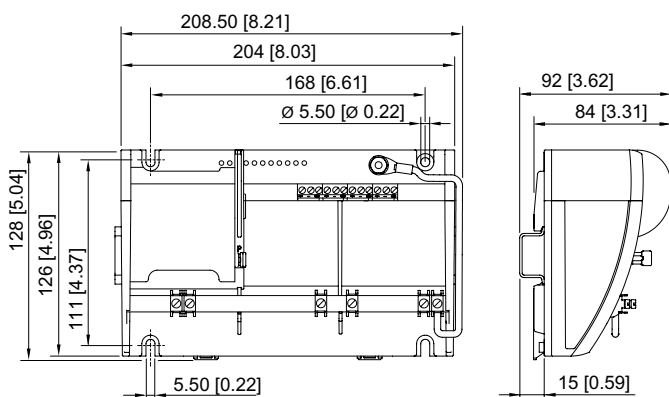



- For connecting eight intrinsically safe (FISCO/Entity) fieldbus devices in Zone 1 and Class I, Div. 1
- Operated using High Power Trunk concept
- Reduced start-up current thanks to power management and short-circuit limiting with disconnection

WebCode 9411D



9411/21 series Ex i field device couplers for installation in Zone 1 and Class I, Div. 2 with galvanic separation can be used for interference-free connection of eight FF H1 or PROFIBUS PA field devices on the High Power Trunk. The spurs with type of protection "ia" can be used for fieldbus devices in Zone 1 and Class I, Div. 1 (FISCO, Entity) and are protected by a short-circuit limiting function. The integrated power management minimizes start-up and short-circuit currents. Available with screw terminals or spring clamp terminals.

09

	NEC® 500 CEC Appendix J					
	Class I		Class II		Class III	
Division	1	2	1	2	1	2
Ex interface	•	•	•	•	•	•
Installation in		•		•		•

	CEC Section 18					
	NEC® 505 Class I			NEC® 506		
Zone	0	1	2	20	21	22
Ex interface	•	•	•	•	•	•
Installation in		•	•		•	•

	IECEX / ATEX					
	Zone	0	1	2	20	21
Ex interface	•	•	•	•	•	•
Installation in		•	•		•	•





Selection Table					
Product Description	ISbus fieldbus technology Field device coupler				
Number of channels	Connection type	Product Type	Art. No.	Weight lb	
8	Screw terminal, detachable	9411/21-230-41	206829	1.96	
Field enclosures in polyester or stainless steel: customer specific solutions on request					

Technical Data	
Explosion Protection	
USA certificate FM	3026646
CAN certificate FM	3026646C
USA marking FM	NI, Class I, Div. 2, Groups A,B,C,D; AIS, Class I,II,III, Div. 1, Groups A,B,C,D,E,F,G; Class I, Zone 1, AEx m e [ia] IIC; T4 at Ta = 75 °C; See Doc. 9411 6 031 001 1
CAN marking FM	NI, Class I, Div. 2, Groups A,B,C,D; AIS, Class I,II,III, Div. 1, Groups A,B,C,D,E,F,G; Class I, Zone 1, Ex m e [ia] IIC; T4 at Ta = 75 °C; See Doc. 9411 6 031 001 1
IECEX gas explosion protection	Ex mb e ib [ia Ga] IIC T4 Gb
IECEX dust explosion protection	[Ex ia Da] IIIC
Certificates	ATEX (BVS), Brazil (ULB), Canada (FM), EAC (Sertium), IECEX (BVS), India (PESO), International (FF), USA (FM)
Auxiliary Power	
Power dissipation max.	1.8 W

Technical Data

Auxiliary Power	
Notes	Auxiliary power is not necessary, the field device coupler will be supplied by the trunk
Input	
Voltage range Trunk	16 – 32 V
Output	
Output current	0 mA ... 41 mA; per spur
Output voltage	Min. 10 V at 41 mA
Ambient Conditions	
Ambient temperature °F	-40°F ... +167°F
Ambient temperature °C	-40 °C ... +75 °C
Mechanical Data	
Field enclosure	Without, DIN rail mounting

Accessories

Figure	Description	Product Type	Art. No.	Weight lb
Grounding bar set for 8 Spurs				
	Grounding bar 9411 spring terminal strap with 10 terminals	-	202775 ▲	0.44
	Grounding bar 9411 screw terminals	-	161930 ▲	0.2
Fieldbus Power Supply				
	Fieldbus power supply and diagnostics	9412/00-310-11s	200586	0.3
Fieldbus Wizard Engineering Tool				
	Engineering tool for segment design of Foundation Fieldbus or Profibus PA fieldbus installations Download under www.fieldbus-solutions.info	-	-	-

Dimensional Drawings (All Dimensions in mm [inches]) – Subject to Alterations

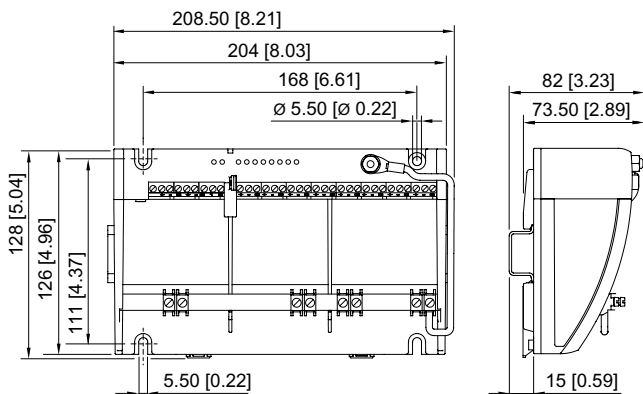



- For connecting four (FISCO, Entity) fieldbus devices in Zone 2 and Class I, Div. 2
- Operated using High Power Trunk concept
- Reduced start-up current thanks to power management and short-circuit limiting with disconnection

WebCode 9411E



9411/24 series Ex i field device couplers for installation in Zone 2 and Class I, Div. 2 with galvanic separation can be used for interference-free connection of up to four intrinsically safe FF H1 or PROFIBUS PA field devices on the High Power Trunk. The spurs with type of protection ia can be used for fieldbus devices in Zones 1 and 2 and Class I, Div. 2 and are protected by a short-circuit limiting function. The integrated power management minimizes start-up and short-circuit currents. Available with screw terminals or spring clamp terminals.

09

	NEC® 500 CEC Appendix J					
	Class I		Class II		Class III	
Division	1	2	1	2	1	2
Ex interface	•	•	•	•	•	•
Installation in		•		•		•

	CEC Section 18					
	NEC® 505		NEC® 506			
	Class I					
Zone	0	1	2	20	21	22
Ex interface	•	•	•	•	•	•
Installation in			•		•	•

	IECEX / ATEX					
		0	1	2	20	21
Zone						
Ex interface	•	•	•	•	•	•
Installation in			•		•	•



Selection Table					
Product Description	ISbus fieldbus technology Field device coupler				
Number of channels	Connection type	Product Type	Art. No.	Weight lb	
4	Screw terminal, detachable	9411/24-330-31	206838	1.62	
Field enclosures in polyester or stainless steel: customer specific solutions on request					

Technical Data	
Explosion Protection	
USA certificate FM	3026646
CAN certificate FM	3026646C
USA marking FM	NI, Class I, Div. 2, Groups A,B,C,D; AIS, Class I,II,III, Div. 1, Groups A,B,C,D,E,F,G; Class I, Zone 2, AEx nA [ia] IIC; T4 at Ta = 75 °C; See Doc. 9411 6 031 004 1
CAN marking FM	NI, Class I, Div. 2, Groups A,B,C,D; AIS, Class I,II,III, Div. 1, Groups A,B,C,D,E,F,G; Class I, Zone 2, Ex nA [ia] IIC; T4 at Ta = 75 °C; See Doc. 9411 6 031 004 1
IECEX gas explosion protection	Ex nA [ia Ga] IIC T4 Gc
IECEX dust explosion protection	[Ex ia Da] IIIC
Certificates	ATEX (BVS), Brazil (ULB), Canada (FM), EAC (Sertium), IECEX (BVS), India (PESO), International (FF), USA (FM)
Auxiliary Power	
Power dissipation max.	1.8 W

Technical Data

Auxiliary Power	
Notes	Auxiliary power is not necessary, the field device coupler will be supplied by the trunk
Input	
Voltage range Trunk	16 – 32 V
Output	
Output current	0 mA ... 41 mA; per spur
Output voltage	Min. 10 V at 41 mA
Ambient Conditions	
Ambient temperature °F	-40°F ... +167°F
Ambient temperature °C	-40 °C ... +75 °C
Mechanical Data	
Field enclosure	Without, DIN rail mounting

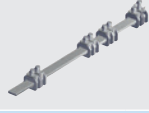
Accessories

Figure	Description	Product Type	Art. No.	Weight lb
Grounding bar set for 4 Spurs				
	Grounding bar 9411 spring terminal strap with 6 terminals	-	202774 ▲	0.28
	Grounding bar 9411 screw terminals	-	161929 ▲	0.18
Fieldbus Power Supply				
	Fieldbus power supply and diagnostics	9412/00-310-11s	200586	0.3
Fieldbus Wizard Engineering Tool				
	Engineering tool for segment design of Foundation Fieldbus or Profibus PA fieldbus installations Download under www.fieldbus-solutions.info	-	-	-

Dimensional Drawings (All Dimensions in mm [inches]) – Subject to Alterations

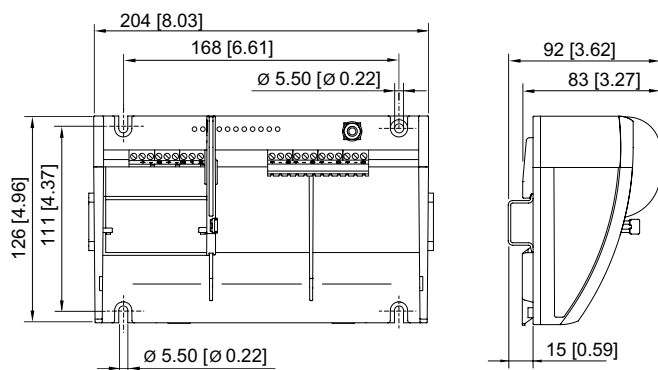



- For connecting eight (FISCO, Entity) fieldbus devices in Zone 2 and Class I, Div. 2
- Operated using High Power Trunk concept
- Reduced start-up current thanks to power management and short-circuit limiting with disconnection

WebCode 9411F



9411/24 series Ex i field device couplers for installation in Zone 2 and Class I, Div. 2 with galvanic separation can be used for interference-free connection of up to eight intrinsically safe FF H1 or PROFIBUS PA field devices on the High Power Trunk. The spurs with type of protection ia can be used for fieldbus devices in Zones 1 and 2 and Class I, Div. 2 and are protected by a short-circuit limiting function. The integrated power management minimizes start-up and short-circuit currents. Available with screw terminals or spring clamp terminals.

09

	NEC® 500 CEC Appendix J					
	Class I		Class II		Class III	
Division	1	2	1	2	1	2
Ex interface	•	•	•	•	•	•
Installation in		•		•		•

	CEC Section 18					
	NEC® 505		NEC® 506			
	Class I					
Zone	0	1	2	20	21	22
Ex interface	•	•	•	•	•	•
Installation in			•		•	•

	IECEX / ATEX					
	0	1	2	20	21	22
Zone						
Ex interface	•	•	•	•	•	•
Installation in			•		•	•





Selection Table					
Product Description	ISbus fieldbus technology Field device coupler				
Number of channels	Connection type	Product Type	Art. No.	Weight lb	
8	Screw terminal, detachable	9411/24-330-41	206839	1.62	
Field enclosures in polyester or stainless steel: customer specific solutions on request					

Technical Data	
Explosion Protection	
USA certificate FM	3026646
CAN certificate FM	3026646C
USA marking FM	NI, Class I, Div. 2, Groups A,B,C,D; AIS, Class I,II,III, Div. 1, Groups A,B,C,D,E,F,G; Class I, Zone 2, AEx nA [ia] IIC; T4 at Ta = 75 °C; See Doc. 9411 6 031 004 1
CAN marking FM	NI, Class I, Div. 2, Groups A,B,C,D; AIS, Class I,II,III, Div. 1, Groups A,B,C,D,E,F,G; Class I, Zone 2, Ex nA [ia] IIC; T4 at Ta = 75 °C; See Doc. 9411 6 031 004 1
IECEX gas explosion protection	Ex nA [ia Ga] IIC T4 Gc
IECEX dust explosion protection	[Ex ia Da] IIIC
Certificates	ATEX (BVS), Brazil (ULB), Canada (FM), EAC (Sertium), IECEX (BVS), India (PESO), International (FF), USA (FM)
Auxiliary Power	
Power dissipation max.	1.8 W

Technical Data

Auxiliary Power	
Notes	Auxiliary power is not necessary, the field device coupler will be supplied by the trunk
Input	
Voltage range Trunk	16 – 32 V
Output	
Output current	0 mA ... 41 mA; per spur
Output voltage	Min. 10 V at 41 mA
Ambient Conditions	
Ambient temperature °F	-40°F ... +167°F
Ambient temperature °C	-40 °C ... +75 °C
Mechanical Data	
Field enclosure	Without, DIN rail mounting

Accessories

Figure	Description	Product Type	Art. No.	Weight lb
Grounding bar set for 8 Spurs				
	Grounding bar 9411 spring terminal strap with 10 terminals	-	202775 ▲	0.44
	Grounding bar 9411 screw terminals	-	161930 ▲	0.2
Fieldbus Power Supply				
	Fieldbus power supply and diagnostics	9412/00-310-11s	200586	0.3
Fieldbus Wizard Engineering Tool				
	Engineering tool for segment design of Foundation Fieldbus or Profibus PA fieldbus installations Download under www.fieldbus-solutions.info	-	-	-

Dimensional Drawings (All Dimensions in mm [inches]) – Subject to Alterations

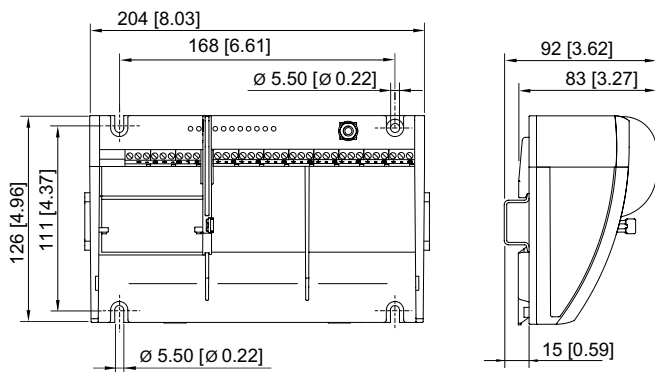



- For connecting four, eight or 12 fieldbus devices in Zone 2 and Class I, Div. 2
- Ex nA or ic spurs
- Operated using High Power Trunk concept
- Reduced start-up current thanks to power management and short-circuit limiting with disconnection

WebCode **9410A**



9410 series Ex n field device couplers for installation in Zone 2 and Class I, Div. 2 can be used for interference-free connection of up to 12 FOUNDATION Fieldbus H1 or PROFIBUS PA field devices on the High Power Trunk. The spurs with type of protection nA or ic can be used for fieldbus devices in Zones 2 (ic, nA) and 1 (d, q, m) and Class I, Div. 2 and are protected by a short-circuit limiting function. The integrated power management minimizes start-up and short-circuit currents.

	NEC® 500 CEC Appendix J					
	Class I		Class II		Class III	
Division	1	2	1	2	1	2
Ex interface		•				
Installation in		•				

	CEC Section 18 NEC® 505 NEC® 506					
	Class I					
Zone	0	1	2	20	21	22
Ex interface			•			
Installation in			•			

	IECEX / ATEX					
	Zone	0	1	2	20	21
Ex interface			•			
Installation in			•			

09

Selection Table					
Product Description	ISbus fieldbus technology Field device coupler				
Number of channels	Connection type	Product Type	Art. No.	Weight lb	
12	Screw terminals, pluggable	9410/34-330-60	207906	1.98	
Field enclosures in polyester or stainless steel: Customer specific solutions on request					

Technical Data	
Explosion Protection	
USA certificate FM	3026646
CAN certificate FM	3026646C
USA marking FM	NI, Class I, Div. 2, Groups A,B,C,D; AIS, Class I,II,III, Div. 2, Groups A,B,C,D,E,F,G; Class I, Zone 2, AEx nA [ic] IIC; T4 at Ta = 75 °C; See Doc. 9410 6 031 001 1
CAN marking FM	NI, Class I, Div. 2, Groups A,B,C,D; AIS, Class I,II,III, Div. 2, Groups A,B,C,D,E,F,G; Class I, Zone 2, Ex nA [ic] IIC; T4 at Ta = 75 °C; See Doc. 9410 6 031 001 1
IECEX gas explosion protection	Ex nA [ic] IIC T4 Gc
Certificates	ATEX (BVS), Brazil (ULB), Canada (FM), EAC (Sertium), IECEX (BVS), International (FF), USA (FM)
Auxiliary Power	
Power dissipation max.	1.2 W
Notes	Auxiliary power is not necessary, the field device coupler will be supplied by the trunk

Technical Data

Input

Voltage range Trunk 9 – 32 V

Output

Output current 0 mA ... 41 mA; per spur

Output voltage Min. 10 V at 41 mA

Ambient Conditions

Ambient temperature °F -40°F ... +167°F



Ambient temperature °C -40 °C ... +75 °C

Mechanical Data

Field enclosure Without, DIN rail mounting

Spurs ic only in connection with an ic-voltage-limited fieldbus power supply (e.g. R. STAHL 9412/01 or 9412/02)

Accessories

Figure	Description	Product Type	Art. No.	Weight lb
Fieldbus Power Supply				
	For supply of a non-intrinsically safe trunk. Advanced version (Diagnosis and Alarming integrated).	9412/00-320-11k	200589	0.3
Fieldbus Wizard Engineering Tool				
	Engineering tool for segment design of Foundation Fieldbus or Profibus PA fieldbus installations Download under www.fieldbus-solutions.info	-	-	-
Terminator				
	Fieldbus Terminator "Ex m"	9418/01-201-10	168062 ▲	0.18

Dimensional Drawings (All Dimensions in mm [inches]) – Subject to Alterations

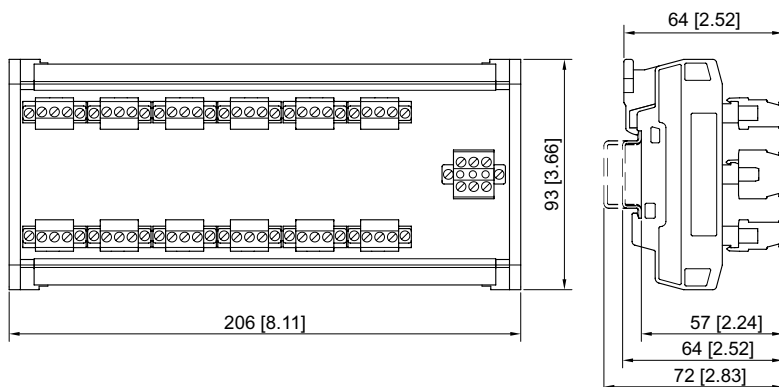



- "i" version of Zone 1 and Class I, Div. 2 EOL resistor for FISCO/ Entity fieldbuses and "m" version for non-intrinsically safe fieldbuses (High Power Trunk)
- Extremely compact design for installation in M20 line entrances
- For use directly in enclosures or field devices

WebCode **9418A**



9418 series fieldbus terminators perform the role of end-of-line resistors for PROFIBUS PA or FOUNDATION™ Fieldbus H1 fieldbuses. Ex i and Ex m versions are available for intrinsically safe FISCO/ Entity and non-intrinsically safe (High Power Trunk) fieldbuses. The extremely compact design saves space when installing the terminators in M20 line entrances. They are easy to spot, even when installed.

	NEC® 500 CEC Appendix J					
	Class I		Class II		Class III	
Division	1	2	1	2	1	2
Ex interface	•	•	•	•	•	•
Installation in	•	•	•	•	•	•

	CEC Section 18					
	NEC® 505 Class I			NEC® 506		
Zone	0	1	2	20	21	22
Ex interface		•	•			
Installation in		•	•			

	IECEX / ATEX					
	Zone	0	1	2	20	21
Ex interface		•	•		•	•
Installation in		•	•		•	•

09

Selection Table				
Product Description	ISbus fieldbus technology Fieldbus terminator			
Version	Fieldbus	Product Type	Art. No.	Weight lb
Ex m fieldbus terminator	Non-intrinsically safe (Ex e)	9418/01-201-10	168062	0.18

Technical Data	
Variant	Ex m fieldbus terminator
Explosion Protection	
USA certificate FM	3026646
CAN certificate FM	3026646C
USA marking FM	NI, Class I, Div. 2, Groups A,B,C,D; T5 at Ta = 75 °C, T6 at Ta = 40 °C; DIP, Class II,III, Div. 2, Groups E,F,G; T5 at Ta = 75 °C, T6 at Ta = 40 °C Class I, Zone 1, AEx mb IIC; T5 at Ta = 75 °C, T6 at Ta = 40 °C; Class II,III, Zone 21, AEx mbD; T100 °C, at Ta = 75 °C, T65 °C at Ta = 40 °C; See Doc. 9410 6 031 001 1
CAN marking FM	NI, Class I, Div. 2, Groups A,B,C,D; T5 at Ta = 75 °C, T6 at Ta = 40 °C; DIP, Class II,III, Div. 2, Groups E,F,G; T5 at Ta = 75 °C, T6 at Ta = 40 °C Class I, Zone 1, Ex mb IIC; T5 at Ta = 75 °C, T6 at Ta = 40 °C; Class II,III, Zone 21, Ex mbD; T100 °C, at Ta = 75 °C, T65 °C at Ta = 40 °C; See Doc. 9410 6 031 001 1
IECEX gas explosion protection	Ex mb IIC T6/T5 Gb
IECEX dust explosion protection	Ex tb IIIC T65 °C ... T100 °C Db
Certificates	ATEX (PTB), Brazil (ULB), Canada (FM), EAC (Sertium), IECEX (PTB), USA (FM)
Electrical Data	
End-of-line resistor capacitance	1 µF
Resistance value	100 Ω

Technical Data	
Variant	Ex m fieldbus terminator
Auxiliary Power	
Nominal voltage V_{nom}	< 32 V
Ambient Conditions	
Ambient temperature °F	-40°F ... +104°F (IIC T6) (T65 °C) -40°F ... +167°F (T5) (T100 °C)
Ambient temperature °C	-40 °C ... +40 °C (IIC T6) (T65 °C) -40 °C ... +75 °C (T5) (T100 °C)
Cable glands must be ordered as accessories. Please contact your local sales office for more details.	

Dimensional Drawings (All Dimensions in mm [inches]) – Subject to Alterations

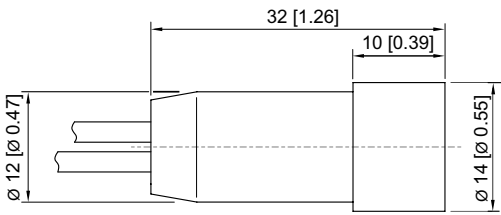

09

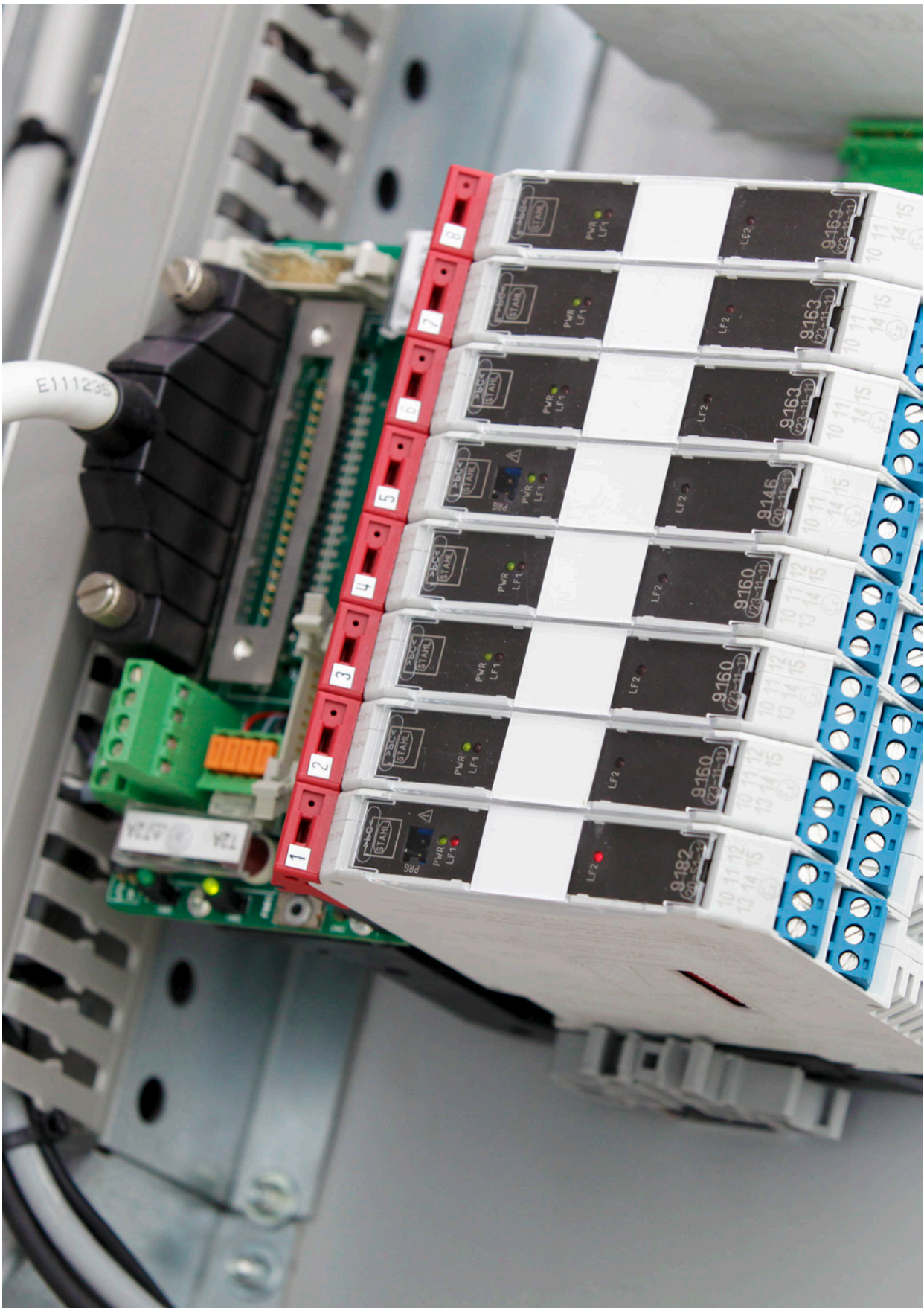

HMI SYSTEMS – CHAPTER INDEX TABLES



Product	Series	Page	WebCode
HMI Systems – Chapter Index Tables			
Operator Interface		293	
Thin Client, Panel PC, KVM System		292	

For additional products and information please refer to r-stahl.com

HMI Systems



MANTA HMI



EAGLE HMI



SHARK HMI



RAPTOR HMI

		Haz. Area Rating						Screen Size				High Brightness		
		Cl. I, Div. 2	Cl. II, Div. 2	Zone 2	Zone 1	Cl. I, Div. 1*	Cl. II, Div. 1**	10.4"	15"	21.5"	24"	> 1000 nit	< 400 nit	
Thin Client	MT-598	X	X	X						X		X		Page 315
	ET-577	X		X	X	X					X		X	Page 301
	MT-538	X	X	X					X			X		Page 315
	MT-536	X	X	X					X				X	Page 309
	MT-516	X	X	X				X						
	ET-598	X	X	X	X		X			X		X		Page 315
	ET-538	X	X	X	X		X		X			X		
	ET-536	X	X	X	X		X		X				X	Page 309
	ET-516	X	X	X	X		X	X					X	

* in conjunction with Y-Purged panel
 ** Cl. II, Div. 1 certified only by CEC

10 a

		Haz. Area Rating						Screen Size				High Brightness		
		Cl. I, Div. 2	Cl. II, Div. 2	Zone 2	Zone 1	Cl. I, Div. 1*	Cl. II, Div. 1**	10.4"	15"	21.5"	24"	> 1000 nit	< 400 nit	
Panel PC	MT-498	X	X	X						X		X		Page 315
	ET-477	X		X	X	X					X		X	Page 303
	MT-438	X	X	X					X			X		Page 315
	MT-436	X	X	X										Page 309
	MT-416	X	X	X				X					X	
	ET-498	X	X	X	X		X			X		X		Page 315
	ET-438	X	X	X	X		X		X			X		
	ET-436	X	X	X	X		X		X				X	Page 309
	ET-416	X	X	X	X		X	X					X	

* in conjunction with Y-Purged panel
 ** Cl. II, Div. 1 certified only by CEC

		Haz. Area Rating						Screen Size				High Brightness		
		Cl. I, Div. 2	Cl. II, Div. 2	Zone 2	Zone 1	Cl. I, Div. 1*	Cl. II, Div. 1**	10.4"	15"	21.5"	24"	> 1000 nit	< 400 nit	
KVM System	MT-698	X	X	X						X		X		Page 315
	ET-677	X		X	X	X					X		X	Page 301
	MT-638	X	X	X					X			X		Page 315
	ET-698	X	X	X	X		X			X		X		
	ET-638	X	X	X	X		X	X		X		X		

* in conjunction with Y-Purged panel
 ** Cl. II, Div. 1 certified only by CEC

		Haz. Area Rating						Screen Size				High Brightness		
		Cl. I, Div. 2	Cl. II, Div. 2	Zone 2	Zone 1	Cl. I, Div. 1*	Cl. II, Div. 1**	10.4"	15"	21.5"	24"	> 1000 nit	< 400 nit	
Operator Interface	MT-336	X	X	X				X				X		Page 309
	MT-316	X	X	X				X				X		
	ET-336	X	X	X	X		X		X			X		
	ET-316	X	X	X	X		X	X				X		
* in conjunction with Y-Purged panel														
** Cl. II, Div. 1 certified only by CEC														

Operator Interface		Haz. Area Rating						Screen Size		High Brightness		
		Cl. I, Div. 2	Cl. II, Div. 2	Zone 2	Zone 1	Cl. I, Div. 1	Cl. II, Div. 1	7"		> 1000 nit	< 500 nit	
ET-208-TX-W00-DC-GLN		X	X	X	X			X			X	Page 321



Product	Series	Page	WebCode
HMI Device Platforms			
Device Platform EAGLE for Zone 2 / Class I, Div. 2 Panel Mount Device		309	
Device Platform MANTA for Zone 1 / Class I, Div. 2 Operator Station		301	
Device Platform MANTA for Zone 1 / Class I, Div. 2 Panel Mount Device		303	
Device Platform RAPTOR for Zone 1 / Class I, Div. 2 Operator Interfaces and Operator Stations		321	
Device Platform SHARK for Zone 1 / Class I, Div. 2 Operator Station "Rugged Design"		315	
HMI Technologies for all Applications			
HMI Technologies for all Applications		295	
Operating and Monitoring Systems – Overview			
Device Platform EAGLE for Zone 2 / Class I, Div. 2		305	
Device Platform MANTA for Zone 1 / Class I, Div. 2		297	
Device Platform RAPTOR for Zone 1 / Class I, Div. 2		319	
Device Platform SHARK for Zone 1 / Class I, Div. 2		311	

For additional products and information please refer to r-stahl.com

HMI Technologies for all Applications

HMI products and solutions from series EXICOM have been designed for worldwide operation in hazardous areas, rough ambient conditions, cleanrooms and onboard ships. Be it in the form of a 7" Operator Panel or a 24" widescreen terminal, we offer safe high-tech in all shapes and sizes: KVM systems, Thin Clients, Panel PCs, Operator Interfaces and peripherals.

Our four different device platforms provide the ideal solution for each application: SHARK HMIs for oil and gas applications and rough ambient conditions, MANTA HMIs for process automation, universally applicable EAGLE devices for machine automation, and the 7" RAPTOR Operator Interfaces with integrated software for visualization and operation of machines, for logistics or for tank-farm automation.

	Device platform SHARK	Device platform MANTA	Device platform EAGLE	Device platform RAPTOR
Area of application	Oil & Gas rough ambient conditions	Process automation	Machine automation	Oil & Gas rough ambient conditions Machine automation
Technology	KVM systems Thin Client Panel PC	KVM systems Thin Client Panel PC	Thin Client Panel PC Operator Interface	Operator Interface

GLOSSARY OF HMI TERMS

USING THE ET-438 AS AN EXAMPLE

ZONE	TECHNOLOGY / SERIES	DISPLAY SIZE	DEVICE PLATFORM
ET	2 Operator Interfaces 3 Operator Interfaces 4 Panel PC 5 Thin Clients 6 KVM Systems	0 10.4" (800 x 600) 3 15" (1024 x 768) 7 24" (1920 x 1080) Full HD (1920 x 1200) 9 21.5" (1920 x 1080) Full HD	6 EAGLE Machine Operation, universal 7 MANTA Pharmaceutical Industry Fine Chemical Industry Hygienic Applications 8 SHARK / RAPTOR Oil & Gas, Harsh Environments

10 b

SERIES 500 / SERIES 400

SERIES 500 consists of THIN CLIENTS and SERIES 400 of PANEL PCs for installation in hazardous and industrial areas. The Thin Clients have been designed for application within modern Server-Client structures, thus providing flexible access options from different HMIs to different servers. The Panel PCs provide additional local applications on-site. Each of our device platforms has a fast processor, such as Intel®, AMD or Atom, which ensure fast software processing. The Panel PCs can also operate in extreme temperatures.

SERIES 300 / SERIES 200

Series 300 and 200 both are "Operator Interfaces", i.e. HMI devices with integrated software for visualizing and operating machinery and for logistics and tank-farm automation. SERIES 300 with 10" / 15" monitors is universally applicable, i.e. also in machine operation. SERIES 200 consisting of 7" Operator Interfaces is suitable for extreme ambient conditions (e.g. oil & gas), as well as in the pharmaceutical, chemical, and life sciences industries.

SERIES 600

SERIES 600 consists of KVM systems where the data issuing PC is installed separately in the safe area and the HMI on-site in the hazardous or industrial area. KVM systems are ideal for classic point-to-point connections, i.e. for access from one HMI to one dedicated PC.

Overview

The operating devices of R. STAHL's MANTA device platform with displays size 24" are geared towards the requirements of the pharmaceutical, chemical, and life science industries. They can display complex processes in brilliant image quality on widescreens and have glass touchscreens. They can be flexibly configured and are available as panel mount devices (PM) or Operator Stations (OS) inside enclosures.

Panel mount device



Operator Station



Device Platform MANTA

Thin Clients have generally been designed for application within virtual networks and modern Server-Client structures, thus providing flexible access options from each operating station to different servers / operating stations.

Our Thin Clients are configured with our Remote HMI firmware, the most intelligent and up-to-date visualization solution for real, virtual and cloud-based workstations, making HMI solutions ready for the industrial Internet of Things. This new firmware versions ensures a secure and permanent process communication in the network. Functions such as AUTOMATIC RECONNECT, FALL-BACK MECHANISM and ETHERNET REDUNDANCY ensure a permanent data connection. In the extremely unlikely event of an extraordinary communication failure, error messages and diagnosis tools ensure swift resolution of the underlying problem. Our intuitive App concept makes the firmware easy as pie to operate. Remote access via RDP and VNC is standard; via the App concept, third-party products such as browsers, CCTV, Citrix etc. can be integrated in the kiosk mode.

THIN CLIENT INTEGRATION DEVICE PLATFORM MANTA

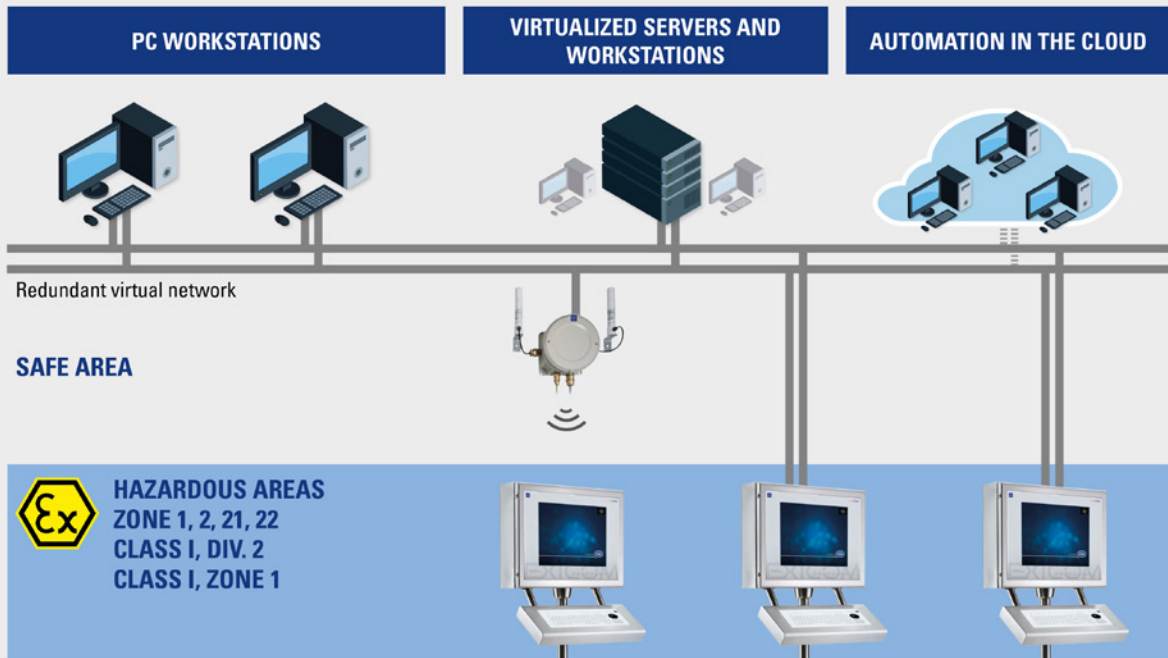

10 b

Device Platform MANTA

The widescreen Panel PCs have been developed to include state-of-the-art PC technology in fanless, modular, and industrial design and are configured with Intel® Atom processors as a standard. Windows® 10 IoT Enterprise 2016 LTSC, Windows Embedded Standard 7 or Windows 7 Ultimate are available as operating systems. As ready-to-run systems, the PCs have an integrated device control panel, a virtual keyboard, UWF and HORM filters, and brightness control.

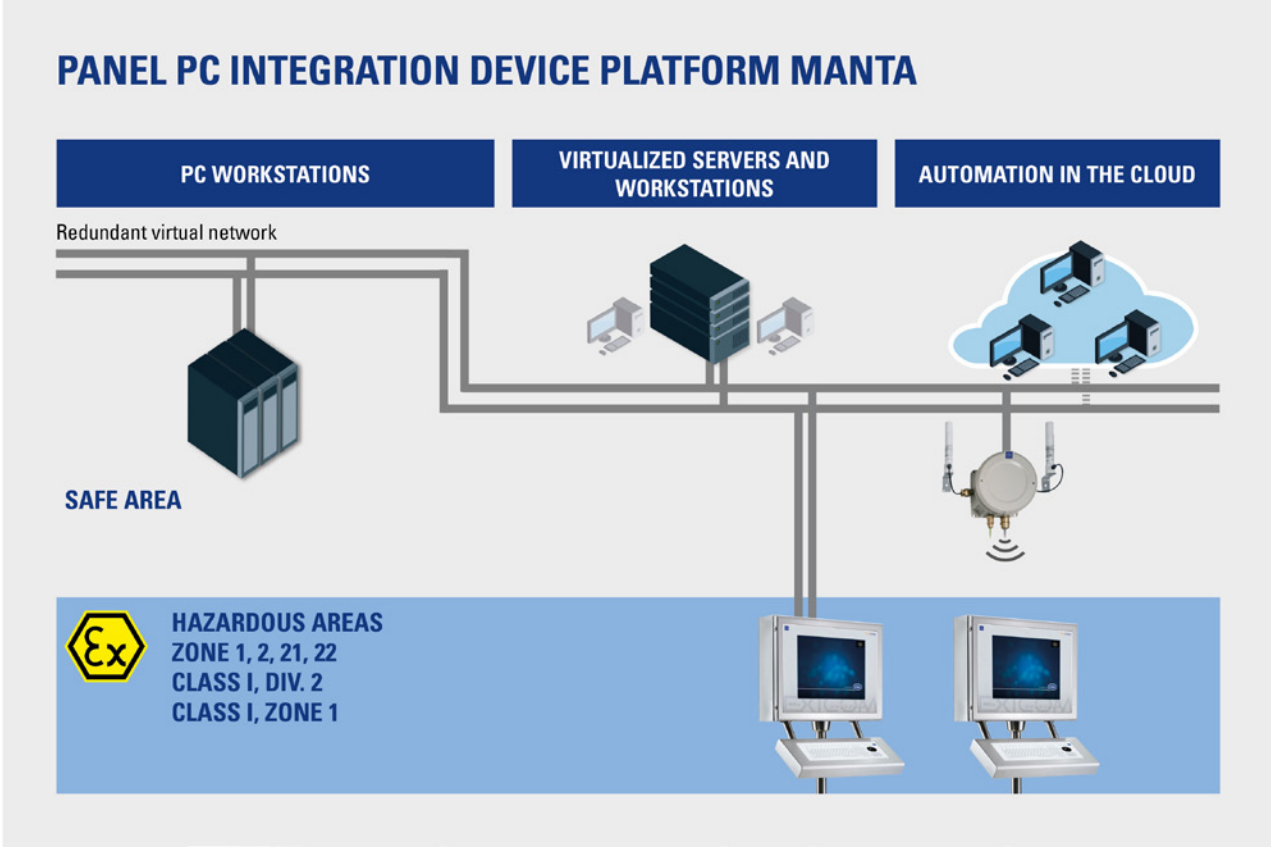

Device Platform MANTA

Designed for point-to-point connections, our KVM systems with widescreen format are suitable for many different applications. A simple, secure data connection to the data-issuing PC is established via DVI, VGA and USB (plug & play). Data can be transmitted over a distance of up to 2 km / [1.24 miles] with fiber optics and up to 150 m / [492.13 ft] with a copper connection via CAT7, and can also be used for CCTV applications. The KVM design is future-proof and can be updated for future hardware platforms.

KVM INTEGRATION DEVICE PLATFORM MANTA

PC WORKSTATIONS

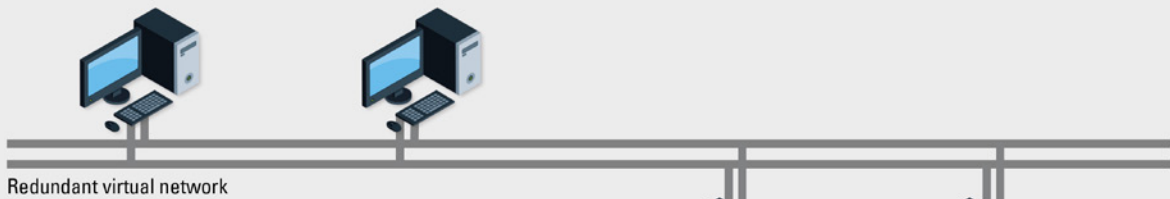

SAFE AREA

 **HAZARDOUS AREAS**
ZONE 1, 2, 21, 22
CLASS I, DIV. 2
CLASS I, ZONE 1



10b



- Modular Operator Station up to Zone 1, 2, 21, 22, Cl. I, Div.1 (in conjunction with Y-Purged panel), Cl. I, Div. 2 and Cl. I, Zone 1
- Stainless steel enclosure 304SS IP66
- Optional resistive glass or foil touchscreen
- Thin Client (SERIES 500), Panel PC (SERIES 400) or KVM (SERIES 600)



	NEC® 500 CEC Appendix J					
	Class I		Class II		Class III	
Division	1	2	1	2	1	2
Ex interface						
Installation in	•	•				

	CEC Section 18					
	NEC® 505 Class I			NEC® 506		
Zone	0	1	2	20	21	22
Ex interface						
Installation in		•	•			

	IECEX / ATEX					
	0	1	2	20	21	22
Zone						
Ex interface						
Installation in		•	•		•	•

10 b

Selection Table			
Technology HMI type	Thin Client Operator Station		
Product Type		Art. No.	Weight lb
ET-577-2TX-230A010002M-212021000000		271589	142.2

Technical Data	
Explosion Protection	
Certification NEC	CSA 70011698
Certification CEC	CSA 70011698
NEC gas explosion protection	Class I, Zone 1 AEx e q [ia] IIC T4 Gb
CEC gas explosion protection	Ex e q [ia] IIC T4 Gb Class I, Division 2
Application range (Zones)	1 2 21 22
Certifications	ATEX, IECEX, NEC, CEC, EAC, PESO
Electrical Data	
Processor type	AMD GX
RAM	4 GB
Data memory	64 GB SSD
Ethernet / Data	2x 10/100Base-TX (Ex e)
Operating system	Windows 10 IoT Enterprise
Image	Remote Firmware V5.xx
Voltage range AC	100 – 240 V
Display	
Display size inch	24

Technical Data

Display	
Display resolution	1920 x 1080 / 1680 x 1050 / 1280 x 1024
Mechanical Data	
Degree of protection (IP)	IP66
Mounting / Installation	
Enclosure type	Stainless steel enclosure 304SS (FR)
Mounting type	for mounting on stand
Components	
Keyboard	Keyboard with trackball, layout US

Possible Versions

Installation in	ET – up to Zone 1, 21, Cl. I, Div. 1 (in conjunction with Y-Purged panel), Cl. I, Div. 2, Cl. I, Zone 1
Technology	Thin Client Remote HMI V5.xx, ATOM E3845 1.9 GHz Panel PC Windows 10 IoT, ATOM E3845 1.9 GHz KVM DVI3 system
Touchscreen	Resistive foil or glass touchscreen
Keyboard layout	DE, US, FR, CH, ES, other on request
Pointing devices	Trackball, touchpad, joystick
Network interfaces	100Base-TX, 100Base-SX
Enclosure	Stainless steel 316SS
Other versions on request	

Accessories

Description	Art. No.	Weight lb
Storage Media		
USBi-Drive-32GB USB Stick, intrinsically safe, 32 GB	261529	1.1 lb
USBi-Drive-32GB-Recovery USB Stick, intrinsically safe, 32 GB with recovery and backup function	261530	1.1 lb
Transmission Unit KVM Box		
KVM-DIGITAL-IPEPS-PLUS-US Digital KVM over IP transmission unit Remote monitoring and control, Peer-to-Peer Video resolution up to 1920 x 1200 pixels Connection to PC via HDMI / USB Data transmission via CAT cable up to 100 m / [328.08 ft]	275796	3.64 lb
Accessories KVM-Box		
KVM-DIGITAL-RMK10 Mounting bracket set 19" for mounting of one KVM-Box on 19" rack, 1HE	275797	2.2 lb
KVM-DIGITAL-RMK8 Mounting bracket set 19" for mounting of two KVM-Boxes on 19" rack, 1HE	275798	0 lb
Enclosure Accessories		
HSG-xxx-V2A-MPW-450mm-2M25-1M20 Elbow with coupling Material: V2A (SS304) 1.4301, brushed 240 Length 450 mm [17.71 inches], diameter: 60.3 mm [2.37 inches] (pipe), 2x M25 1x M20	252958	15.43 lb
HSG-xxx-V2A-MPFL-1240mm-2M25-1M20 Stand with coupling Material: V2A (SS304) 1.4301, brushed 240 Length 1240 mm [48.82 inches], diameter: 88.9 mm [3.5 inches] (pipe), 2x M25 1x M20	252949	22.05 lb



- Modular operator interface up to Zone 1, 2, 21, 22, Cl. I, Div. 2 and Cl. I, Zone 1
- Can be installed in hazardous areas without additional enclosure
- Optional resistive glass or foil touchscreen
- Thin Client (SERIES 500), Panel PC (SERIES 400) or KVM (SERIES 600)



	NEC® 500 CEC Appendix J					
	Class I		Class II		Class III	
Division	1	2	1	2	1	2
Ex interface						
Installation in		•				

	CEC Section 18					
	NEC® 505 Class I			NEC® 506		
Zone	0	1	2	20	21	22
Ex interface						
Installation in		•	•			

	IECEX / ATEX					
	Zone	0	1	2	20	21
Ex interface						
Installation in		•	•		•	•

10 b

Selection Table			
Technology	Panel PC		
HMI type	Panel mount device		
Product Type		Art. No.	Weight lb
ET-477-TX-730A200002R-000000000000		274987	70.55

Technical Data	
Explosion Protection	
Certification NEC	CSA 70011698
Certification CEC	CSA 70011698
NEC gas explosion protection	Class I, Zone 1 AEx e q [ia] IIC T4 Gb
CEC gas explosion protection	Ex e q [ia] IIC T4 Gb Class I, Division 2
Application range (Zones)	1 2 21 22
Certifications	ATEX, IECEX, NEC, CEC, EAC, PESO
Electrical Data	
Processor type	ATOM E3845
RAM	4 GB
Data memory	64 GB SSD
Ethernet / Data	10/100Base-TX (Ex e)
Operating system	Windows 10 IoT Enterprise
Power supply	24 VDC
Display	
Display size inch	24
Display resolution	1920 x 1080 / 1680 x 1050 / 1280 x 1024

Technical Data

Display

Touchscreen	Analog resistive glass touchscreen
-------------	------------------------------------

Possible Versions

Installation in	ET – up to Zone 1, 21, Cl. I, Div. 2 and Cl. I, Zone 1
Technology	Thin Client Remote HMI V5.xx, AMD GX Thin Client Remote HMI V5.xx, ATOM E3845 1.9 GHz Panel PC Windows 10 IoT, ATOM E3845 1.9 GHz KVM DVI3 system
Touchscreen	Resistive foil or glass touchscreen
Network interfaces	100Base-TX, 100Base-SX, dual Ethernet 100Base-TX
Other versions on request	

Overview

The Operator Interfaces of the EAGLE device platform are R. STAHL's all-around solutions for operating machinery, processes, tank farms, and filling stations. Thanks to their robust design, they are certified for worldwide operation in hazardous areas and onboard ships. They are vibration- and shock-proof, resistant to corrosive gases (ISA 71.04 G3) and have IP66. As a standard, all models are equipped with touchscreens. The panel mount devices (PM) are flexibly configurable and suitable for operation in temperatures ranging from -20 °C to +55 °C [-4 °F to +131 °F].

Panel mount device



Device Platform EAGLE

R. STAHL's Thin Client with REMOTE HMI FIRMWARE is the smartest and modern visualization solution for real, virtual and cloud-based workstations, and makes HMI solutions fit for the industrial Internet of Things.

- Secure, designed as a closed system running on Windows® 10 IoT Enterprise LTSC, and supportive of customer-specific security concepts
- Simple and user-friendly surface with virtual keyboard, supportive of multi-sessions and dual-monitor setups
- Reliable with redundant Ethernet, automatic reconnect and fall-back mechanism to support redundant server concepts
- RDP and VNC is standard, but the unique app concept allows the integration of third-party applications in kiosk mode, such as browser, CCTV, Citrix,...

THIN CLIENT INTEGRATION DEVICE PLATFORM EAGLE

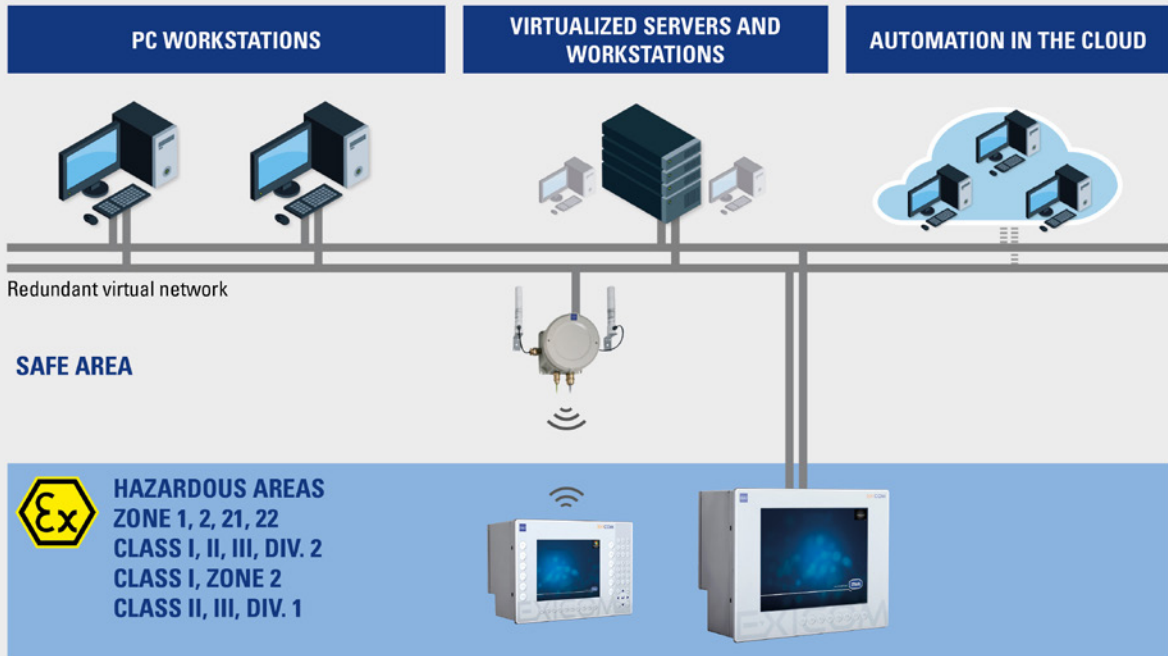

10 b

Device Platform EAGLE

Panel PCs with modern PC technology in a fanless, modular, and industrial design.

- Standard Intel Atom processor
- Windows® 10 IoT Enterprise LTSC, Windows Embedded Standard 7, Windows 7 Ultimate
- “Ready-to-run” system with integrated R. STAHL Device Control Panel, unique virtual keyboard button, Unified Write Filter (UWF), Hibernate Once / Resume Many (HORM), brightness control

PANEL PC INTEGRATION DEVICE PLATFORM EAGLE

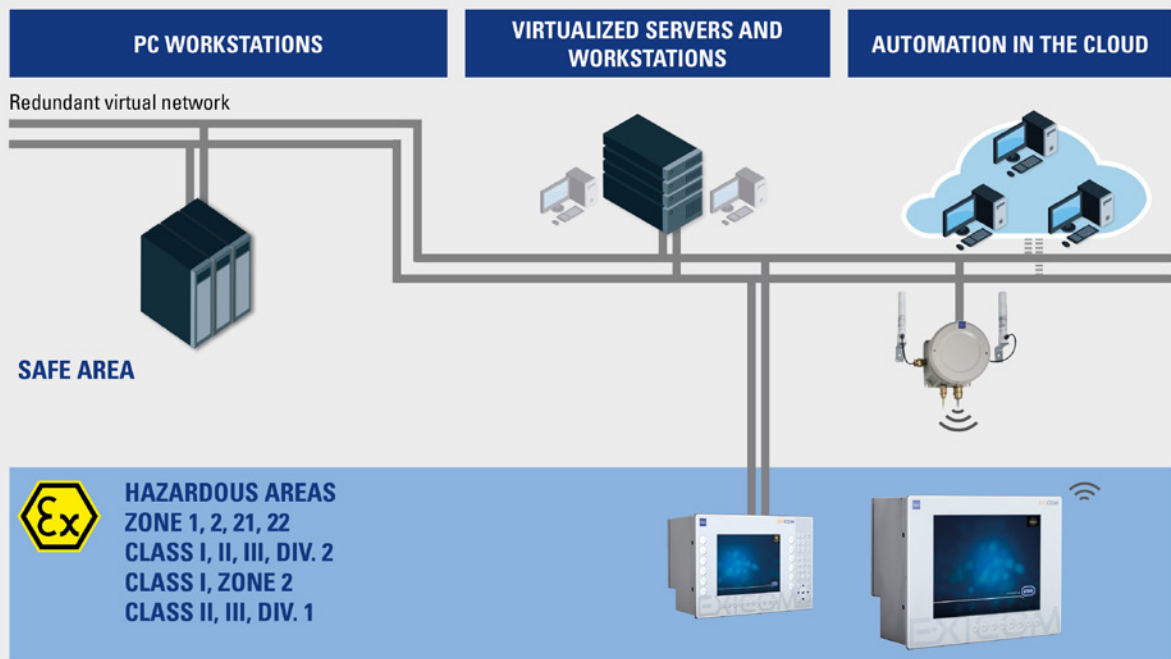

10 b

Device Platform EAGLE

The Operator Interfaces of the EAGLE SERIES 300 are equipped with GMP-compliant fronts and are available with two different display sizes with 10" and 15" in this SERIES. You can connect all important automation devices to the serial and TCP / IP Ethernet interfaces. This gives you the optimum solution for all applications.

- Robust Operator Interfaces for Hazardous Areas Zones 1, 21, 2, 22 and Class I, Div. 2, Class II, III, Div. 1 & 2 and Class I, Zone 2
- Visualization systems under Windows Embedded Compact 7 with MOVICON 11 CE or SPSPPlus RT
- Modular panel mount devices, flexibly configurable

OPERATOR INTERFACE INTEGRATION DEVICE PLATFORM EAGLE

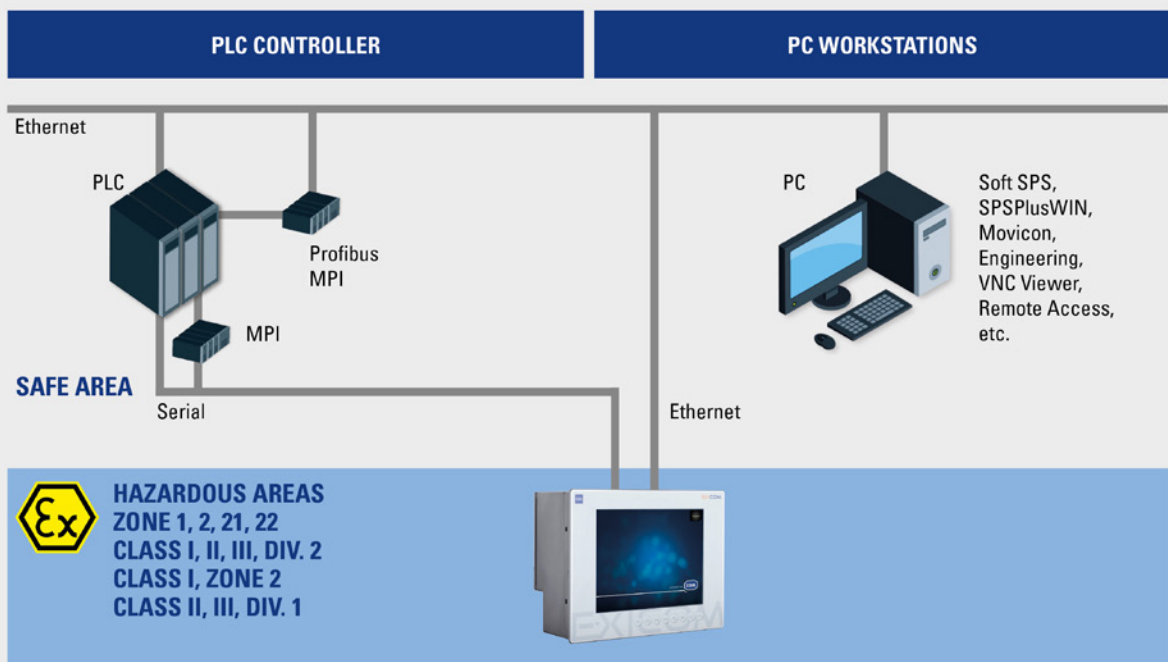

10b

Device Platform EAGLE for Zone 2 / Class I, Div. 2

Panel Mount Device



- Modular operator interface up to Zone 1, 2, 21, 22, Cl. I, Div. 2, Cl. II, III, Div. 1 & 2 and Cl. I, Zone 2
- Can be installed in hazardous areas without additional enclosure
- Resistive foil touchscreen
- Thin Client (SERIES 500), Panel PC (SERIES 400) or Operator Interface (SERIES 300)



	NEC® 500 CEC Appendix J					
	Class I		Class II		Class III	
Division	1	2	1	2	1	2
Ex interface						
Installation in		•	•	•	•	•

	CEC Section 18					
	NEC® 505			NEC® 506		
Zone	0	1	2	20	21	22
Ex interface						
Installation in		•	•			

	IECEX / ATEX					
	0	1	2	20	21	22
Zone	0	1	2	20	21	22
Ex interface						
Installation in		•	•		•	•

10b

Selection Table			
Technology HMI type	Operator Interface Panel mount device		
Product Type		Art. No.	Weight lb
ET-316-A-TX-62031000004-00000000000		261860	29.98
Technology HMI type	Panel PC Panel mount device		
Product Type		Art. No.	Weight lb
ET-416-A-TX-730A100000R-00000000000		268485	29.1
ET-436-A-TX-730A100000R-00000000000		271599	39.68

Technical Data			
Variant	ET-316-A-TX	ET-416-A-TX	ET-436-A-TX
Explosion Protection			
Certification NEC	UL 20130611-E202379	UL 20130611-E202379	UL 20130611-E202379
Certification CEC	CSA 2512677	CSA 2512677	CSA 2512677
NEC gas explosion protection	Class I, Division 2, Groups A, B, C, D Class I, Zone 2, Group IIC	Class I, Division 2, Groups A, B, C, D Class I, Zone 2, Group IIC	Class I, Division 2, Groups A, B, C, D Class I, Zone 2, Group IIC
NEC dust explosion protection	Class II, Division 2, Groups F, G Class III	Class II, Division 2, Groups F, G Class III	Class II, Division 2, Groups F, G Class III
CEC gas explosion protection	Ex d e ia ib mb [ia ib] IIC T4 Gb, Type 4X, IP66	Ex d e ia ib mb [ia ib] IIC T4 Gb, Type 4X, IP66	Ex d e ia ib mb [ia ib] IIC T4 Gb, Type 4X, IP66
CEC dust explosion protection	Ex ia tb [ia ib] IIIC T80°C Db, IP66 Class II, Division 1, Groups E, F, G, T80°C	Ex ia tb [ia ib] IIIC T80°C Db, IP66 Class II, Division 1, Groups E, F, G, T80°C	Ex ia tb [ia ib] IIIC T80°C Db, IP66 Class II, Division 1, Groups E, F, G, T80°C
Application range (Zones)	1 2 21 22	1 2 21 22	1 2 21 22

Technical Data			
Variant	ET-316-A-TX	ET-416-A-TX	ET-436-A-TX
Explosion Protection			
Certifications	ATEX, IECEx, NEC, CEC, EAC, KGS, PESO, INMETRO, CNEX	ATEX, IECEx, NEC, CEC, EAC, KGS, PESO, INMETRO, CNEX	ATEX, IECEx, NEC, CEC, EAC, KGS, PESO, INMETRO, CNEX
Ship certificates	DNV, ABS, LR	DNV, ABS, LR	DNV, ABS, LR
Electrical Data			
Processor type	ATOM E3815	ATOM E3845	ATOM E3845
RAM	2 GB	4 GB	4 GB
Data memory	16 GB SSD	64 GB SSD	64 GB SSD
Ethernet / Data	10/100Base-TX (Ex e)	10/100Base-TX (Ex e)	10/100Base-TX (Ex e)
Operating system	Windows Embedded Compact 7	Windows 10 IoT Enterprise	Windows 10 IoT Enterprise
Image	Movicon CE 4096 I/O Runtime		
Power supply	24 VDC	24 VDC	24 VDC
Display			
Display size inch	10	10	15
Total pixels	800 x 600	800 x 600	1024 x 768
Touchscreen	Analog resistive film touchscreen		

Possible Versions	
Installation in	ET – up to Zone 1, 21, Cl. I, Div. 2, Cl. II, III, Div. 1 MT – up to Zone 2, 22, Cl. I, Div. 2, Cl. II, III, Div. 2
Technology	Thin Client Remote HMI V5.xx, ATOM E3845 1.9 GHz Panel PC Windows 10 IoT, ATOM E3845 1.9 GHz Operator interface ATOM E3815, Windows Embedded Compact 7, SPSPPlus Runtime Operator interface ATOM E3815, Windows Embedded Compact 7, Movicon CE 4096 I/O Runtime
Network interfaces	100Base-FX
Operator Station	Stainless steel 304SS or 316SS Operator Station IP66
Other versions on request	

Accessories		
Description	Art. No.	Weight lb
Storage Media		
USBi-Drive-32GB USB Stick, intrinsically safe, 32 GB	261529	1.1 lb
USBi-Drive-32GB-Recovery USB Stick, intrinsically safe, 32 GB with recovery and backup function	261530	1.1 lb
Software		
SPSPPlusWin 6.xx Project engineering software for all Operator Interfaces	263160	0.22 lb
Movicon11-Dongle Project engineering software Progea Movicon11 (for devices with Progea Movicon Runtime)	241090	1.1 lb

Overview

Rugged – that sums up R. STAHL's operator stations with device platform SHARK. We have designed these HMI systems to be ideally suited to the most adverse ambient conditions. These systems are shock-, vibration-, seawater- and salt spray- proof and have IP66. Thanks to the integrated heater and our innovative application of the chimney effect, they also ensure reliable operation in temperatures ranging from -40 °C to +65 °C [-40 °F to +149 °F]. The display and additional function keys are located underneath a chemically hardened, non-glare glass pane. The standard versions with their multi-touchscreens and sunlight-readable, dimmable displays use state-of-the-art technology; the 21.5" models have card readers for access control as an option, and a further option includes an integrated front camera.

Rugged Design Rigfloor HMI



Rugged Design Operator Station



Device Platform SHARK

R. STAHL's Thin Client with REMOTE HMI FIRMWARE is the smartest and most modern visualization solution for real, virtual and cloud-based workstations, and makes HMI solutions fit for the industrial Internet of Things.

- Secure, designed as a closed system running on Windows® 10 IoT Enterprise LTSC, and supportive of customer-specific security concepts
- Simple and user-friendly surface with virtual keyboard, supportive of multi-sessions and dual-monitor setups
- Reliable with redundant Ethernet, automatic reconnect and fall-back mechanism to support redundant server concepts
- RDP and VNC is standard, but the unique app concept allows the integration of third-party applications in kiosk mode, such as browser, CCTV, Citrix,...

THIN CLIENT INTEGRATION DEVICE PLATFORM SHARK

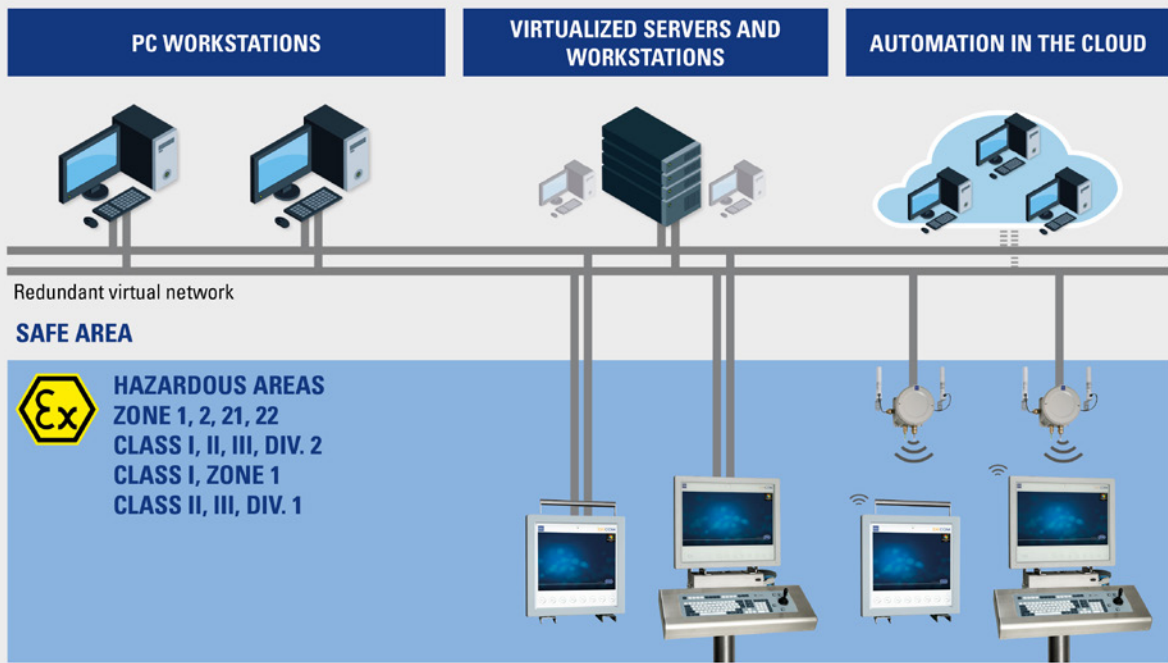

10 b

Device Platform SHARK

R. STAHL provides state-of-the-art PC technology in fanless, modular, and industrial design.

- Standard dual-core processor AMD GX or high-end Core i7, optional with "Trusted Platform Module" TPM
- Windows® 10 IoT Enterprise LTSC, Windows Embedded Standard 7, Windows 7 Ultimate
- "Ready-to-run" system with integrated R. STAHL Device Control Panel, unique virtual keyboard button, Unified Write Filter (UWF), Hibernate Once / Resume Many (HORM), brightness control

PANEL PC INTEGRATION DEVICE PLATFORM SHARK

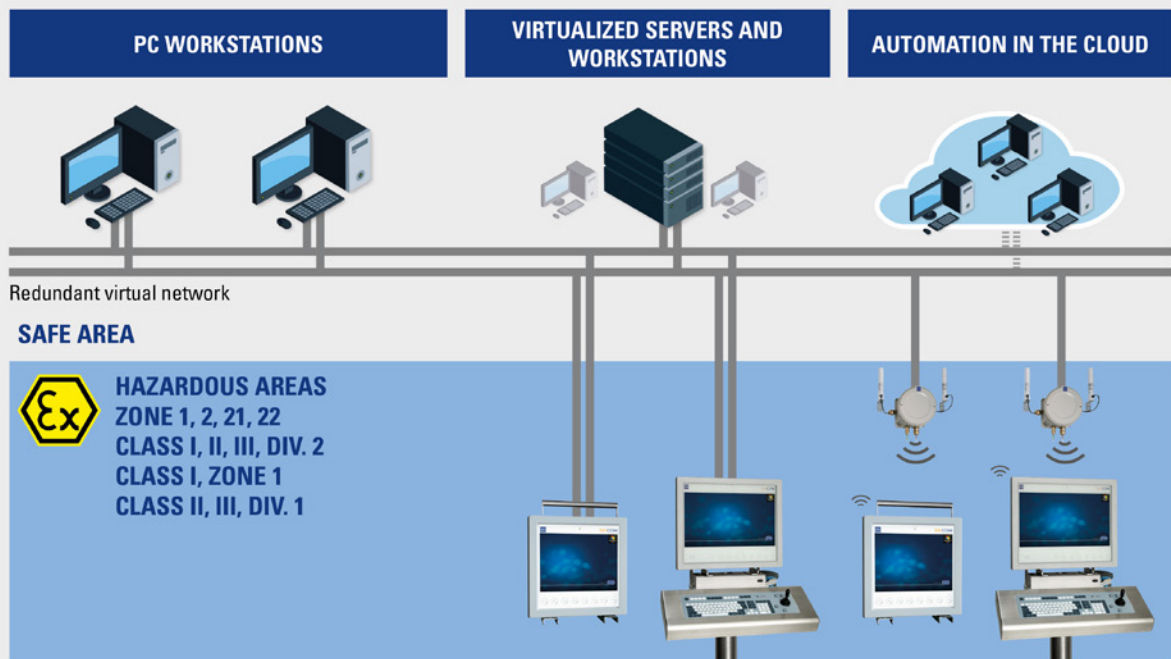

10 b

Device Platform SHARK

In HMI technology, KVM systems are ideal for CCTV applications.

- Fast and latency-free visualization
- Simple and safe connection to DVI or VGA and USB (plug-and-play)
- KVM systems for extension of digital video signals and USB to up to 2 km / [1.24 miles] with fiber optic, and up to 150 m / [492.13 ft] with CAT7
- Future-proof HMI: update possibilities for future hardware platforms

KVM INTEGRATION DEVICE PLATFORM SHARK

PC WORKSTATIONS

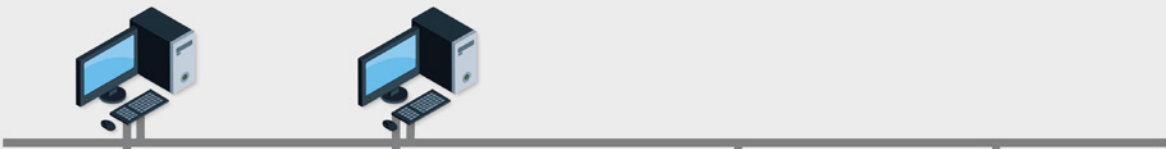

Redundant virtual network

SAFE AREA



HAZARDOUS AREAS
 ZONE 1, 2, 21, 22
 CLASS I, II, III, DIV. 2
 CLASS I, ZONE 1
 CLASS II, III, DIV. 1



10b

Device Platform SHARK for Zone 1 / Class I, Div. 2

Operator Station "Rugged Design"

STAHL



- Operator Station up to Zone 1, 2, 21, 22, Cl. I, II, III, Div.2, Cl. II, III, Div. 1
- With 15 or 21.5 inch display
- Temperature range -40 °C to +65 °C [-40 °F to +149 °F]
- Ruggedized, yet compact, lightweight HMI design with 15 inch display
- Optional sunlight-readable SR display >1000 cd/m²



	NEC® 500 CEC Appendix J					
	Class I		Class II		Class III	
Division	1	2	1	2	1	2
Ex interface						
Installation in		•	•	•	•	•

	CEC Section 18					
	NEC® 505			NEC® 506		
	Class I					
Zone	0	1	2	20	21	22
Ex interface						
Installation in		•	•		•	•

	IECEx / ATEX					
Zone	0	1	2	20	21	22
Ex interface						
Installation in		•	•		•	•

10 b

Selection Table			
Technology	Panel PC		
HMI type	Operator station Rugged Design		
Product Type		Art. No.	Weight lb
ET-438-2TX-2305313000R-B30500000000		271523	52.91
ET-498-2TX-931C313000R-B30500000000		275445	77.16

Technical Data		
Variant	ET-438-2TX	ET-498-2TX
Explosion Protection		
Certification NEC	FM 16 US 0278 X	FM 16 US 0278 X
Certification CEC	FM 16 CA 0141 X	FM 16 CA 0141 X
NEC gas explosion protection	Class I, Zone 1 AEx eb q [ia op is Ga] IIC T4 Gb Class I, Div. 2 Groups A, B, C, D T4	Class I, Zone 1 AEx eb q [ia op is Ga] IIC T4 Gb Class I, Div. 2 Groups A, B, C, D T4
NEC dust explosion protection	Zone 21, AEx tb [ia op is Da] IIIC T115°C Db Class II, Div. 2 Groups F, G T4 Class III	Zone 21, AEx tb [ia op is Da] IIIC T115°C Db Class II, Div. 2 Groups F, G T4 Class III
CEC gas explosion protection	Ex eb q [ia Ga] IIC T4 Gb Class I, Div. 2 Groups A, B, C, D T4	Ex eb q [ia Ga] IIC T4 Gb Class I, Div. 2 Groups A, B, C, D T4
CEC dust explosion protection	Zone 21, Ex tb [ia Da] IIIC T115°C Db Class II, Div. 1 Groups E, F, G T4 Class III	Zone 21, Ex tb [ia Da] IIIC T115°C Db Class II, Div. 1 Groups E, F, G T4 Class III
Application range (Zones)	1 2 21 22	1 2 21 22
Certifications	ATEX, IECEx, EAC, NEC, CEC, CNEX, PESO	ATEX, IECEx, EAC, NEC, CEC, CNEX, PESO
Ship certificates	DNV, ABS	DNV, ABS
Electrical Data		
Processor type	AMD GX	Intel i5

Technical Data		
Variant	ET-438-2TX	ET-498-2TX
Electrical Data		
RAM	4 GB	4 GB
Data memory	60 GB SSD	240 GB SSD
Ethernet / Data	2x 10/100/1000Base-TX (Ex e)	2x 10/100/1000Base-TX (Ex e)
Operating system	Windows 10 IoT Enterprise	Windows 10 IoT Enterprise
Ambient Conditions		
Ambient temperature operation	-40 °C ... +65 °C [-40 °F to +149 °F]	-40 °C ... +65 °C [-40 °F to +149 °F]
Display		
Display size inch	15	21.5
Display resolution	1024 x 768	1920 x 1080
Touchscreen	Capacitive multi-touch	Capacitive multi-touch

Possible Versions	
Installation in	ET – up to Zone 1, 21, Cl. I, II, III, Div.2, Cl. II, III, Div. 1 MT – up to Zone 2, 22, Cl. I, II, III, Div.2, Cl. II, III, Div. 2
Technology	Panel PC Windows 10 IoT, Intel i7 or i5 Thin Client Remote HMI V5.xx, Windows 10 IoT, AMD GX Thin Client Remote HMI V5.xx, Windows 10 IoT, Intel i7 or i5 KVM DVI3 system
Network interfaces	2x 100Base-FX, 1x 10/100/1000Base-TX + WLAN (WLAN not for KVM systems)
Further options	Bluetooth, RFID (only 21.5"), Top Connect device
Other versions on request	

10 b

Top Connect Device Version

Top connect device version for wall and yoke mount with blind plugs and separate connector variants with ROTA® plugs and sockets for a flexible, fast, safe, and mobile connection on site.

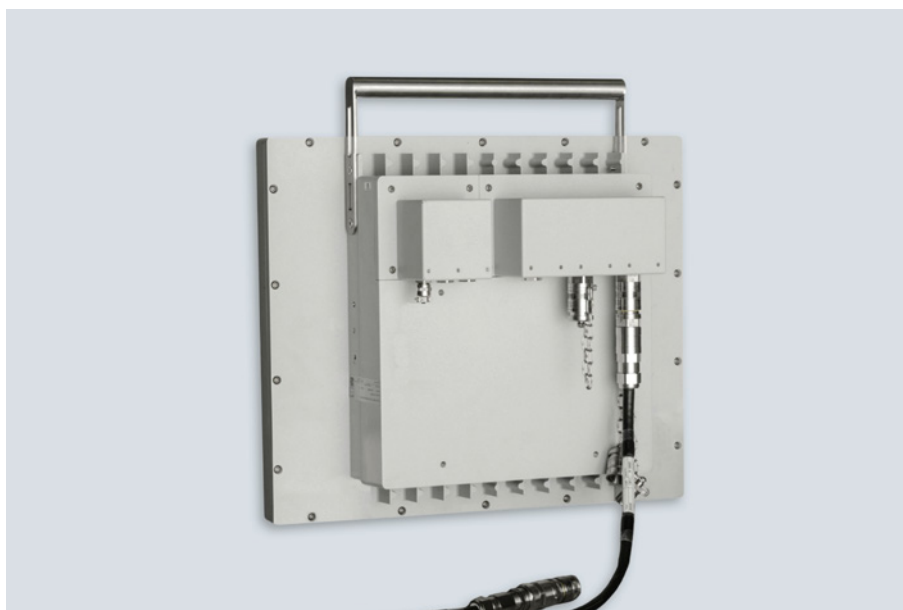

Accessories		
Description	Art. No.	Weight lb
Storage Media		
USBi-Drive-32GB USB Stick, intrinsically safe, 32 GB	261529	1.1 lb
USBi-Drive-32GB-Recovery USB Stick, intrinsically safe, 32 GB with recovery and backup function	261530	1.1 lb
Keyboard / Pointing device Ex i		
KBDi-USB-J-US-HSG-xx8-V4A-YM Keyboard with integrated joystick USB interface 3/5 keys, V4A stainless-steel enclosure (SS316L) Keyboard language: US, QWERTY	254921	27.56 lb
KBDi-USB-M-US-HSG-xx8-V4A-YM Keyboard with integrated mouse USB interface 3/5 keys, V4A stainless-steel enclosure (SS316L) Keyboard language: US, QZERTY	253700	27.56 lb
KBDi-USB-P-US-HSG-xx8-V4A-YM Keyboard with integrated touchpad USB interface 3/5 keys, V4A stainless-steel enclosure (SS316L) Keyboard language: US, QWERTY	250223	22.05 lb
KBDi-USB-TB50-US-HSG-xx8-V4A-YM Keyboard with integrated trackball 50 mm USB interface 3/5 keys, V4A stainless-steel enclosure (SS316L) Keyboard language: US, QZERTY	249706	27.56 lb
Transmission Unit KVM Box		
KVM-DIGITAL-IPEPS-PLUS-US Digital KVM over IP transmission unit Remote monitoring and control, Peer-to-Peer Video resolution up to 1920 x 1200 pixels Connection to PC via HDMI / USB Data transmission via CAT cable up to 100 m / [328.08 ft]	275796	3.64 lb
Accessories KVM-Box		
KVM-DIGITAL-RMK10 Mounting bracket set 19" for mounting of one KVM-Box on 19" rack, 1HE	275797	2.2 lb
KVM-DIGITAL-RMK8 Mounting bracket set 19" for mounting of two KVM-Boxes on 19" rack, 1HE	275798	0 lb
Enclosure Accessories		
HSG-xxx-V4A-MPFL-1240mm-2M25-1M20 Stand with coupling Material: V4A (SS316L) 1.4404, brushed 240 Length 1240 mm [48.82 inches], diameter: 88.9 mm [3.5 inches] (pipe), 2x M25 1x M20	252950	22.05 lb
HSG-xxx-V4A-MPW-450mm-2M25-1M20 Elbow with coupling. Material: V4A (SS316L) 1.4404, brushed 240 Length 450 mm [17.71 inches], diameter: 60.3 mm [2.37 inches] (pipe), 2x M25 1x M20	252959	15.43 lb
HSG-xx8-V4A-YOKE-MOUNT-FIX Yoke mount for xx8 devices Mounting on stand or elbow Material: V4A (SS316L) 1.4404, brushed 240 2x M20, 1x M25 Dimensions (WxHxD): 379.5 mm x 347.5 mm x 156 mm [14.94 inches x 13.68 inches x 6.14 inches]	267444	10.36 lb
HSG-xx8-V4A-WALL-MOUNT-KIT Mounting kit for wall mount of xx8 device swiveling for connection Material: V4A (SS316L) 1.4404, brushed 240 Dimensions (WxHxD): 60 mm x 430 mm x 183 mm [2.36 inches x 16.93 inches x 7.2 inches] including screws for display mounting	267443	0 lb
HSG-xx8-V4A-KB-MOUNT-W Adapter kit for mounting a xx8 keyboard at the wall bracket Material: V4A (SS316L) 1.4404, brushed 240	267451	0 lb
HSG-xx8-V4A-HANDLE-FEET-KIT Set consisting of handle and feet Material: V4A (SS316L) 1.4404, brushed 240 Dimensions handle (WxHxD): 361 mm x 186 mm x 27 mm [14.21 inches x 7.32 inches x 1.06 inches] Dimensions feet (WxHxD): 94 mm x 192 mm x 195 mm [3.7 inches x 7.56 inches x 7.68 inches]	267456	0 lb

Accessories

Description	Art. No.	Weight lb
Enclosure Accessories		
HSG-xx8-V4A-HANDLE Handle Material: V4A (SS316L) 1.4404, brushed 240 Dimensions (WxHxD): 361 mm x 186 mm x 27 mm [14.21 inches x 7.32 inches x 1.06 inches]	267447	0 lb
HSG-xx8-V4A-FEET-SET 1 pair feet Material: V4A (SS316L) 1.4404, brushed 240 Dimensions (WxHxD): 94 mm x 192 mm x 195 mm [3.7 inches x 7.56 inches x 7.68 inches]	267455	0 lb
HSG-x38-V4A-SUNSHADE-KIT Sun roof with bracket for x38 devices including handle Material: V4A (SS316L) 1.4404, brushed 240 Dimensions (WxHxD): 596 mm x 546 mm x 136 mm [23.46 inches x 21.5 inches x 5.35 inches]	267446	9.92 lb
HSG-x98-V4A-SUNSHADE-KIT Sun roof with bracket for x98 devices including handle Material: V4A (SS316L) 1.4404, brushed 240 Dimensions (WxHxD): 596 mm x 546 mm x 136 mm [23.46 inches x 21.5 inches x 5.35 inches]	267445	15.43 lb
HSG-xx8-V4A-WIFI-MOUNT-KIT-YOKE Antenna iANT212 including connection cable and mounting bracket for mounting at the Yoke Mount Material: V4A (SS316L) 1.4404, brushed 240 Dimensions (WxHxD): 60 mm x 430 mm x 183 mm [2.36 inches x 16.93 inches x 7.2 inches]	267453	0 lb
HSG-xx8-V4A-WIFI-MOUNT-KIT-W Antenna iANT212 including connection cable and mounting bracket for mounting at the wall bracket Material: V4A (SS316L) 1.4404, brushed 240 Dimensions (WxHxD): 60 mm x 430 mm x 183 mm [2.36 inches x 16.93 inches x 7.2 inches]	267452	0 lb
HSG-x38-V2A-FP-Mounting-Kit Mounting plate for front panel mount of x38 device Material: V2A (SS304) 1.4301, brushed 240 including mounting material for mounting the display	259976	11.02 lb
HSG-x98-V2A-FP-Mounting-Kit Mounting plate for front panel mount of x98 device Material: V2A (SS304) 1.4301, brushed 240 including mounting material for mounting the display	257498	4.41 lb

10 b

Overview

R. STAHL's RAPTOR device platform provides robust and versatile Operator Interfaces, for example for drilling rigs, tank-farm automation or the pharmaceutical and life sciences industries. They can withstand temperatures ranging from $-40\text{ }^{\circ}\text{C}$ to $+65\text{ }^{\circ}\text{C}$ [$-40\text{ }^{\circ}\text{F}$ to $+149\text{ }^{\circ}\text{F}$], are impact resistant with IP69 and easily operated as conveniently as a smartphone. The sunlight-readable 7" widescreen display with capacitive touchscreen shows processes with great contrast and in brilliant colors. Based on the operating system WEC7 the systems can be configured with the software packages SPSPPlus RT or MOVICON CE for the immediate operation. The Operator Interfaces are available as panel mount devices or Operator Stations with enclosure.

Panel mount device



Operator Station with stainless steel keys



Device Platform RAPTOR

The Operator Interfaces RAPTOR are useable for hazardous areas, Zone 1, 2, 21 and 22, Class I, II, Div. 2. RAPTORs are extremely robust, salt fog and waterproof, fail-safe, and reliable in 24/7 operation, even in harshest environmental conditions.

- HMI with integrated operating system and visualization software
- For applications in tank farms and oil rigs
- For machine and heat tracing operations
- IP69 rating
- High vibration and shock resistance
- From -40 °C ... +65 °C [-40 °F ... +149 °F]
- MOVICON CE / SPSPPlus RT / Browser
- Ethernet

OPERATOR INTERFACE INTEGRATION DEVICE PLATFORM RAPTOR

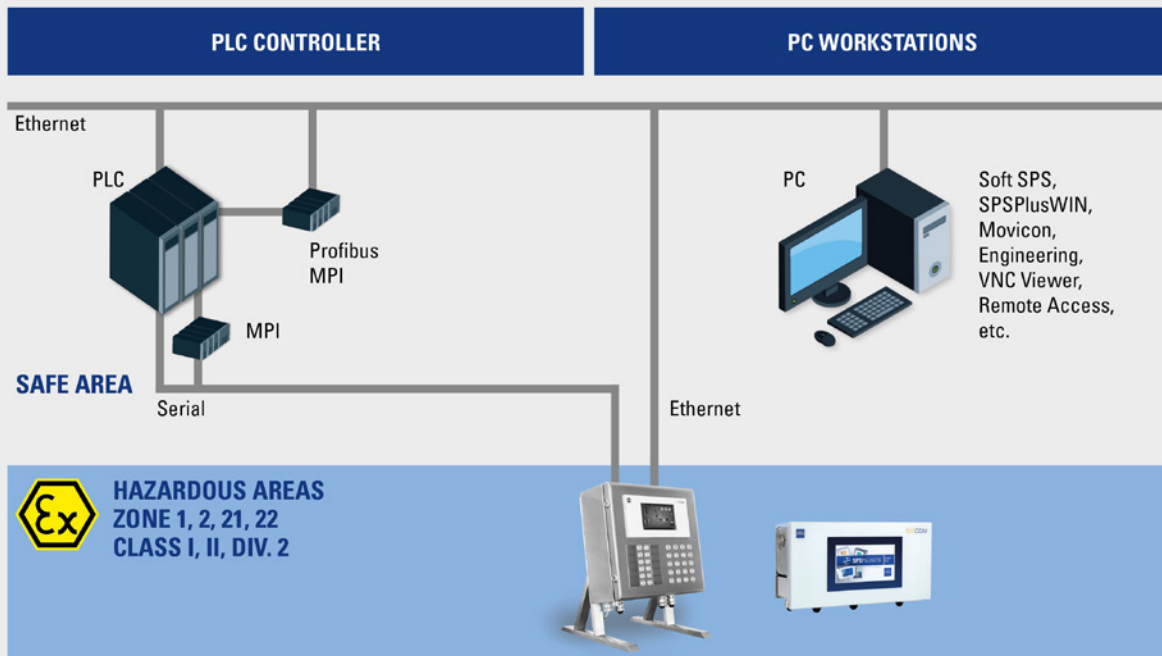

10b

Device Platform RAPTOR for Zone 1 / Class I, Div. 2

Operator Interfaces and Operator Stations

STAHL



- Operator interface up to Zone 1, 2, 21, 22, Cl. I, II, Div. 2 can be installed in hazardous areas without additional enclosure
- Projected-capacitive glass touchscreen
- Flexible enclosure configuration possible



	NEC® 500 CEC Appendix J					
	Class I		Class II		Class III	
Division	1	2	1	2	1	2
Ex interface						
Installation in		•		•		

	CEC Section 18					
	NEC® 505 Class I			NEC® 506		
Zone	0	1	2	20	21	22
Ex interface						
Installation in		•	•		•	•

	IECEX / ATEX					
	Zone	0	1	2	20	21
Ex interface						
Installation in		•	•		•	•

10 b

Selection Table			
Technology HMI type	Operator Interface Panel mount device		
Product Type		Art. No.	Weight lb
ET-208-TX-401030000Q4-000500000000		272904	8.82

Technical Data	
Explosion Protection	
Certification NEC	UL E202379
Certification CEC	UL E202379
NEC gas explosion protection	Class I, Zone 1, AEx e ib q [ib] IIC T4 Gb
NEC dust explosion protection	Zone 21, AEx tb ib [ib] IIIA/IIIC T115°C Db
CEC gas explosion protection	Class I, Zone 1, AEx e ib q [ib] IIC T4 Gb
CEC dust explosion protection	Zone 21, AEx tb ib [ib] IIIA/IIIC T115°C Db
Application range (Zones)	1 2 21 22
Certifications	ATEX, IECEX, EAC, PESO, CNEX, KGS, JPNEx, NEC, CEC
Electrical Data	
Processor type	Cortex A8
Ethernet / Data	10/100Base-TX (Ex e)
Operating system	Windows Embedded Compact 7
Image	Movicon CE 4096 I/O Runtime
Power supply	24 VDC
Display	
Display size inch	7
Total pixels	800 x 480

Technical Data

Display	
Touchscreen	Capacitive glass touchscreen
Front plate (display)	Glass on aluminum
Front plate special design	Glass neutral

Possible Versions

Operator Station	Stainless steel 304SS or 316SS Operator Station IP66
Other versions on request	

Accessories

Description	Art. No.	Weight lb
Storage Media		
USBi-Drive-32GB USB Stick, intrinsically safe, 32 GB	261529	1.1 lb
USBi-Drive-32GB-Recovery USB Stick, intrinsically safe, 32 GB with recovery and backup function	261530	1.1 lb
Software		
SPSPlusWin 6.xx Project engineering software for all Operator Interfaces	263160	0.22 lb
Movicon11-Dongle Project engineering software Progea Movicon11 (for devices with Progea Movicon Runtime)	241090	1.1 lb

10 b



10 b

NETWORK AND WIRELESS SOLUTIONS

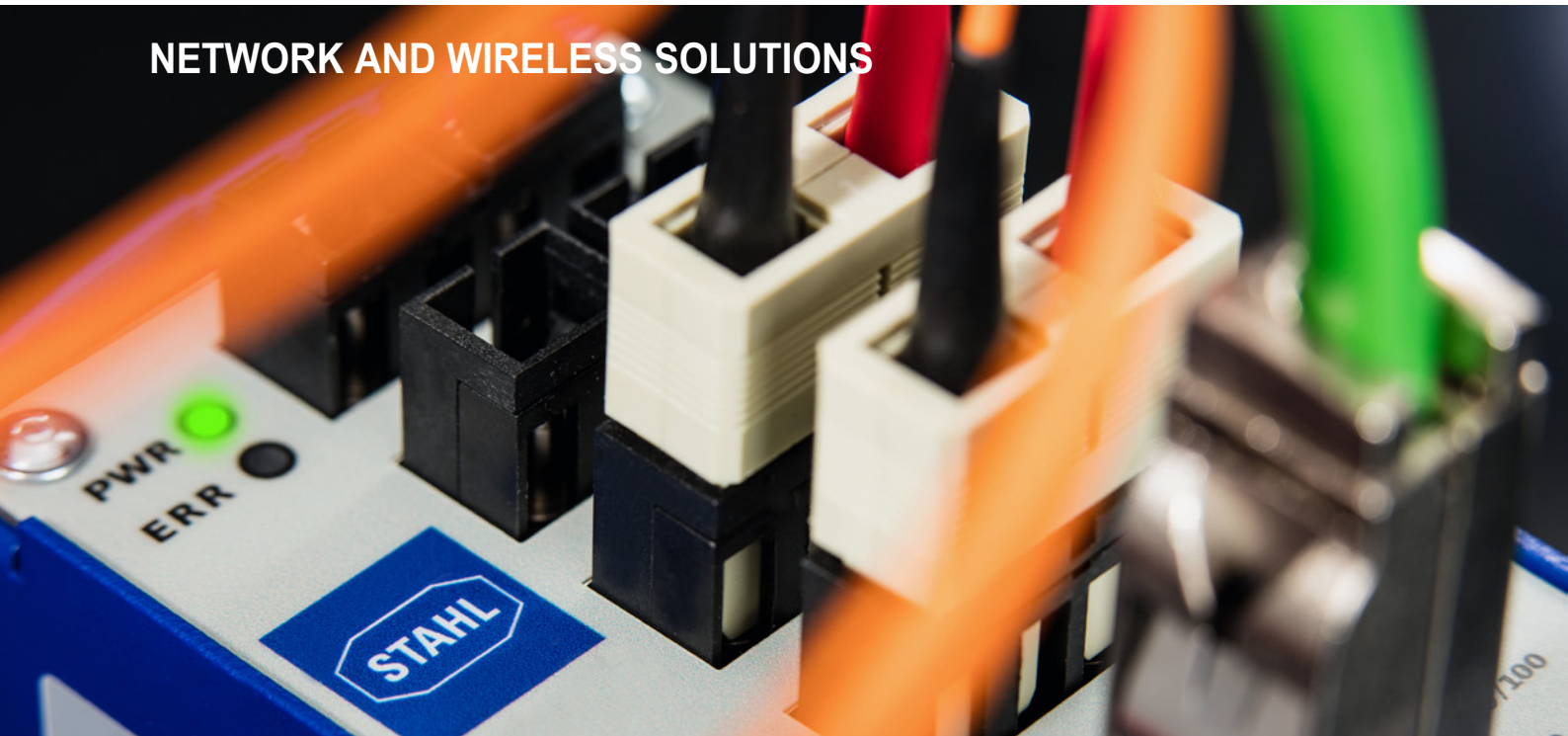

Product	Series	Page	WebCode
General			
Communication Protocols Modbus RTU and Profibus DP		326	
Overview of the Portfolio for Ethernet Networks		325	
HFisolator			
HFisolator inclusive Ex d Bushing	9730	327	9730A
Isolating Repeater for Profibus / Modbus RTU			
Fiber Optics Fieldbus Isolating Repeater for Use in Class I, Div. 2 and Zone 2	9186/5	340	9186B
Fieldbus Isolating Repeater	9185/12	338	9185B
Fieldbus Isolating Repeater with an Intrinsically Safe Interface	9185/11	336	9185A
Media Converter			
Media Converter	9721	331	9721A
Unmanaged Switch	9721	333	9721B
Wi-Fi Access Point			
Wi-Fi Access Point for Use in Class I, II, Div. 1	8265	329	8265C

For additional products and information please refer to r-stahl.com

Overview of the Portfolio for Ethernet Networks

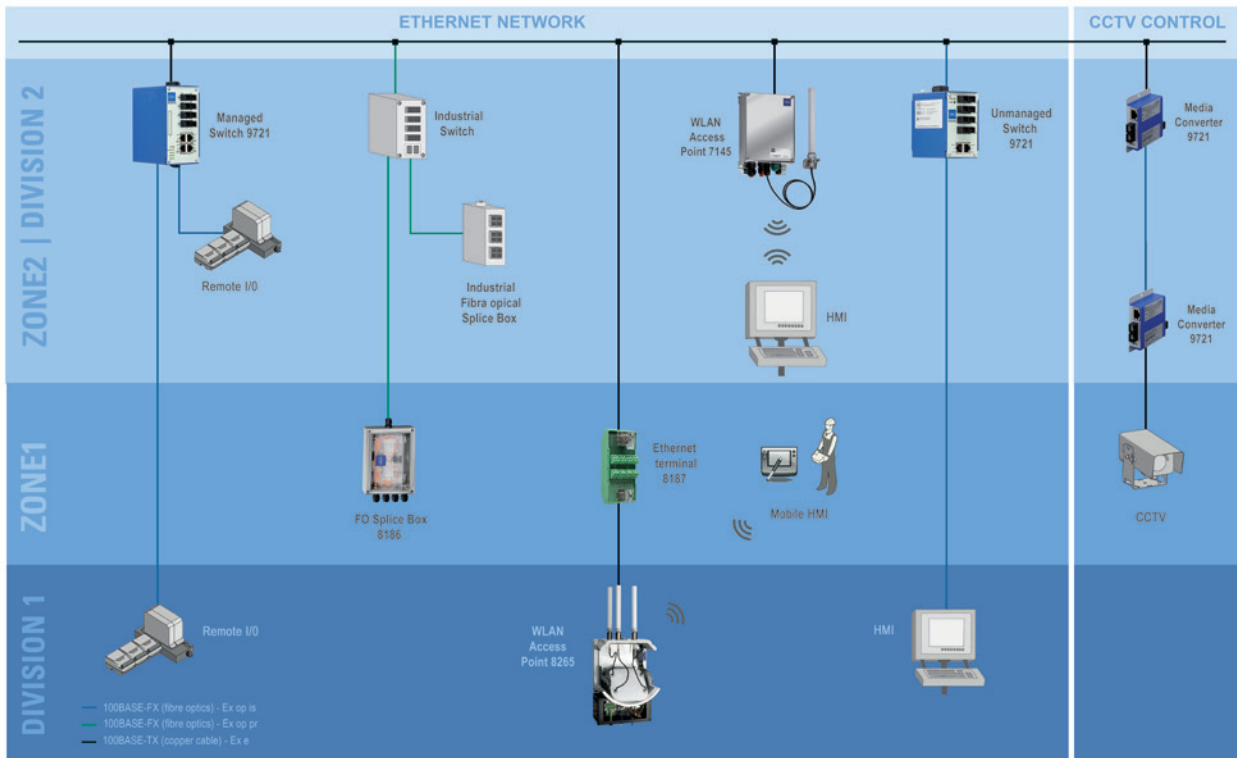

Wireless Technology in Process Automation

Application of wireless technology in the process industry offers new possibilities for plant operators to optimize production processes and to follow entirely new paths. This opens up a wide field of applications with a variety of solutions for the operator. R. STAHL takes this trend into account in various ways.

You have a wireless modem without Ex-approval and you want to use it in a hazardous area? Based on components like the HFisolator, we will take your wireless solution into the hazardous area. The HFisolator converts common wireless signals into explosion-protected, intrinsically safe wireless signals. The signals are galvanically separated and transmitted between input and output. Furthermore, R. STAHL offers a number of standard products. This includes: Wi-Fi Access Point for Cl. I, II, Div. 1 and Zone 1, 2.

Ethernet in Process Automation

Increased safety 'e' type of protection in accordance with IEC/EN 60079-7 can be used to install your equipment in hazardous areas. A certified 8187 series Ethernet terminal for transmission rates of up to 1 Gbit/sec (1000Base-T) is available for convenient connection in a Cl. I, II, Div. 1 and Zone 1 Ex e enclosure. For Ethernet installations over long distances and/or in environments where there may be significant interference or other influences, fiber optic cables are the best choice. R. STAHL offers a number of solutions for hazardous areas in this regard: By using the 'op is' type of protection in accordance with IEC/EN 60079-28, fiber optic cables can be routed into Cl. I, II, Div. 1 and Zone 0 areas in a similar way to intrinsically safe circuits, which means that cables can be connected and disconnected during operation. The 9721 series media converters and switches are certified for installation in Cl. I, Div. 2 and Zone 2 with up to four fiber optic cable connections for Cl. I, Div. 1 and Zone 0. You can choose between multi-mode or, for distances of up to 18.6 mi / 30 km, single-mode connections. Alternatively, the 'op pr' type of protection – which is based on increased safety 'e' – can also be used in Zone 1.

Communication Protocols Modbus RTU and Profibus DP

The Modbus RTU and Profibus DP communication protocols are proven technologies in the world of process automation. Both technologies are ideal for transmitting data in bandwidths that exceed the capacity of fieldbuses such as Profibus PA or FF H1.

For use in hazardous areas (especially Cl. I, Div. 1, Zone 1): The explosion protection type intrinsic safety 'i' is ideal for transmission over copper conductors, and the explosion protection type inherently safe optical radiation 'op' is ideal for transmission over fiber optics.

The advantage of both intrinsic safety and inherently safe optical radiation is that the plug connectors can be connected or disconnected without deactivating the communication nodes. In addition, plug connectors largely correspond to proven plug connectors in industrial areas. R. STAHL offers a series of isolating repeaters that lets you create network topologies, based on either copper conductors or fiber optics. If necessary, we can even offer solutions for radio transmission areas.

All solutions feature easy installation and operation. The fiber optic isolating repeaters can be used to create redundant point-to-point, line or ring structures to ensure high availability of communication.



- Allows you to use standard industrial antennas and standard coaxial plug connectors in hazardous areas
- Flexible, can be used in a very wide temperature range
- Enables project-specific wireless solutions

WebCode **9730A**



The 9730 series HFisolator converts standard radio signals into intrinsically safe radio signals so that standard industrial antennas and coaxial plug connectors can be used in hazardous areas. This allows for the development of project-specific solutions with Ex d encapsulation of radio devices, which differ only slightly from standard industrial solutions in terms of the way they are used.

	NEC® 500 CEC Appendix J					
	Class I		Class II		Class III	
Division	1	2	1	2	1	2
Ex interface	•		•			
Installation in	•		•			

	CEC Section 18 NEC® 505 NEC® 506					
	Class I					
Zone	0	1	2	20	21	22
Ex interface						
Installation in						

	IECEX / ATEX					
	Zone	0	1	2	20	21
Ex interface	•	•	•	•	•	•
Installation in		•	•		•	•

11

Selection Table			
Frequency	500 MHz ... 6 GHz		
Thread size	Product Type		Art. No. Weight lb
NPT3/4	9730/47-25		258160 0.88

Technical Data	
Explosion Protection	
USA/CAN certificate UL	E358609
USA marking UL	Class I, Div. 1, Groups A,B,C,D; Class II, Groups F,G
CAN marking UL	Class I, Div. 1, Groups A,B,C,D; Class II, Groups F,G
IECEX gas explosion protection	Ex db mb [ia Ga] IIA/IIB/IIC T5/T6 Gb
IECEX dust explosion protection	Ex mb tb [ia Da] IIIC T100 °C ... T80 °C Db
IECEX firedamp protection	Ex db mb [ia Ma] I Mb
Certificates	ATEX (EXA), Canada / USA (UL), IECEX (EXA)

Technical Data

Electrical Data

Insertion loss	typical
	Frequency band Universal
	Frequency
	500 MHz 1.3 dB
	1.4 GHz 0.6 dB
	1.7 GHz 0.6 dB
	2.5 GHz 0.6 dB
	3.9 GHz 1.2 dB
	4.9 GHz 1.2 dB
	5.4 GHz 0.8 dB
	6 GHz 2 dB

Inside plug connector RP-SMA plug

Outside plug connector N-type socket

Ambient Conditions

Ambient temperature °F -40°F ... +185°F (T100 °C) (T80 °C)

Ambient temperature °C -40 °C ... +85 °C (T100 °C) (T80 °C)

Storage temperature °F -40°F ... +185°F

Storage temperature °C -40 °C ... +85 °C

Mechanical Data

Degree of protection (IP) IP65

Material Stainless steel

Dimensional Drawings (All Dimensions in mm [inches]) – Subject to Alterations

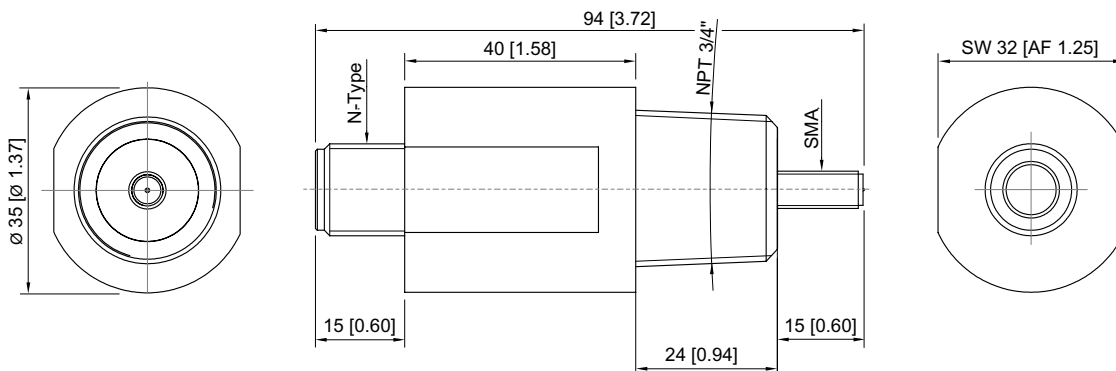



- Provides Wi-Fi functionality for Cl. I, II, Div. 1
- Project-specific built-in components for Wi-Fi or other wireless technologies of your choice
- Robust field enclosure suitable for industrial applications

WebCode **8265C**



The 8265 series Wi-Fi access point enables wireless data transmission via Wi-Fi in Cl. I, II, Div. 1, for instance in order to retrieve data or control processes via smartphone, tablet or notebook. The Wi-Fi access point is easy to install and can also be used over a large temperature range and in virtually all conditions thanks to its robust enclosure.

	NEC® 500 CEC Appendix J					
	Class I		Class II		Class III	
Division	1	2	1	2	1	2
Ex interface						
Installation in	•	•	•	•		

	CEC Section 18					
	NEC® 505 Class I			NEC® 506		
Zone	0	1	2	20	21	22
Ex interface						
Installation in		•	•		•	•



	IECEX / ATEX					
	Zone	0	1	2	20	21
Ex interface						
Installation in		•	•		•	•

11

Selection Table					
Version	8265/6 Ex d enclosure				
Product Description	Wi-Fi access point According to specification				
Grid-bound interface	Antenna cable interface	Product Type	Art. No.	Weight lb	
Ethernet 100BASE-T, 1000BASE-T	N-type socket, intrinsically safe Ex ia	8265/6-....			0
The radio interface uses ISM, 2.4 GHz and 5 GHz frequency bands. Please note that local regulations may limit the use of the device.					
Please contact your responsible distributor for ordering information.					

Technical Data	
Explosion Protection	
USA marking ETL	Class I, Div. 1, Groups A,B,C,D Class II Div. 1, Groups F,G
CAN marking ETL	Class I, Zone 1, IIC, T5 Zone 21, IIB, T5
IECEX gas explosion protection	Ex d e [ia Ga] IIC T6 Gb
IECEX dust explosion protection	Ex tb [ia Da] IIIC T130 °C Db
Certificates	ATEX (PTB), EAC (CCVE), CAN (ETL), IECEX (PTB), USA (ETL)
Electrical Data	
Antenna diversity	MIMO
Radio standards	802.11 depending on the built-in device
Configuration	depends on the built-in device

Technical Data	
Ambient Conditions	
Ambient temperature °F	-4°F ... +140°F Depending on the built-in device
Ambient temperature °C	-20 °C ... +60 °C Depending on the built-in device
Mechanical Data	
Degree of protection (IP)	IP66
Min. dimensions	236 x 236 x 227 mm
Max. dimensions	335 x 505 x 281 mm
Dimensions note	Depending on the built-in device
Components	
Available for Aruba	AP92, AP-324 and others
Available for Cisco	Cisco 2702e, Cisco 2802e
Available for ProSoft	RLX2-IHNF
Available for Siemens	SCALANCE W1788,W780,W770,W760

Accessories			
Figure	Description	Art. No.	Weight lb
Antennas			
	Omnidirectional, 2.4 / 5 GHz ISM band 6/8 dBi antenna gain	207407	0.82
Mounting kit			
	Mounting kit for antenna	207408	0.35

Antennas for use in the offshore applications are available on request.



- For 100 Mbit/s Ethernet with inherently safe "op is" fiber optic in Cl. I, II, III, Div.1 and Zone 0, 1 or 2
- Range up to 3.1 mi / 5 km (multi-mode) or up to 18.6 mi / 30 km (single-mode)
- Increased temperature range of -22 ... +158 °F / -30 to +75 °C
- Easy commissioning, no configuration required
- Installation in Cl. I, Div. 2, Zone 2 and safe area

WebCode 9721A



The Media Converter is used to convert electrical Ethernet signals (TX) into optical Ethernet signals (FX). The optical Ethernet signals are used for operation in hazardous areas of Cl. I, II, III Div. 1 and Zone 0, 1, 2 with the type of protection Ex "op is".

Therefore, conventional fiber optic cables can also be used in hazardous areas and may be connected and disconnected during operation (hot swap).

The Media Converter (multi-mode) is particularly suitable for operation of Remote I/O systems IS1+ in Cl. I, Div. 1 and Zone 1.

	NEC® 500 CEC Appendix J					
	Class I		Class II		Class III	
Division	1	2	1	2	1	2
Ex interface	•	•	•	•	•	•
Installation in		•				

	CEC Section 18 NEC® 505 NEC® 506					
	Class I					
Zone	0	1	2	20	21	22
Ex interface	•	•	•	•	•	•
Installation in			•			

	IECEX / ATEX					
	Zone	0	1	2	20	21
Ex interface	•	•	•	•	•	•
Installation in			•			•

Selection Table						
Product variant	Media converter FX op is / TX SC for Cl. I, Div. 2 and Zone 2					
FO fiber type	FO transmission distance	Interface 1	Interface 2	Product Type	Art. No.	Weight lb
Multi-mode	3.1 mi / 5 km [OM3, OM4] 2.8 mi / 4 km [OM1]	1 Port, 100 Base-FX MM SC	1 Port, 100 Base-TX Cu, RJ45	9721/13-11-14	220381 ▲	0.53
Single-mode	18.6 mi / 30 km [OS1, OS2]	1 Port, 100 Base-FX SM SC	1 Port, 100 Base-TX Cu, RJ45	9721/13-11-54	220382 ▲	0.53

Single-mode version is not suitable for direct connection to Remote I/O IS1+.

Technical Data	
Explosion Protection	
USA certificate FM	FM17US0054X
CAN certificate FM	FM17CA0030X
USA marking FM	Class I, Div. 2, Groups A,B,C,D; Class I, Zone 2, AEx nA [op is] IIC T4 Gc; Ta = -30°C to +75°C; See Doc. 9721 6 031 001 1
CAN marking FM	Class I, Div. 2, Groups A,B,C,D; Class I, Zone 2, Ex nA [op is] IIC T4 Gc; Ta = -30°C to +75°C; See Doc. 9721 6 031 001 1
IECEX gas explosion protection	Ex nA [op is T6 Ga] IIC T4 Gc

Technical Data	
Explosion Protection	
IECEX dust explosion protection	[Ex op is Da] IIIC
Certificates	ATEX (TUR), Canada (FM), EAC (STV), IECEx (TUR), India (PESO), USA (FM)
Ship approval	ABS, CCS, ClassNK, DNV GL, RINA
Electrical Data	
Connection Ethernet Interface	RJ 45 plug connector
Transfer rate	10/100 Mbit/s Auto-negotiation
Operating mode	Half duplex, Full duplex Auto-MDI(X)
Auxiliary Power	
Power consumption max.	2.5 W
Nominal voltage V_{nom}	24 V DC
Polarity reversal protection	Yes
Current consumption max.	200 mA
Ambient Conditions	
Ambient temperature °F	-22°F ... +167°F
Ambient temperature °C	-30 °C ... +75 °C
Mechanical Data	
Degree of protection (IP)	IP20
Enclosure material	Stainless steel, powder-coated
Optical Interfaces see page 335	

Accessories		Art. No.	Weight lb
Figure	Description		
	Patch cable for connection of IS1+ Ethernet CPU 9441 with media converter 9721; plug LC / SC; length 3.8 ft / 3 m	220911 ▲	-

Dimensional Drawings (All Dimensions in mm [inches]) – Subject to Alterations

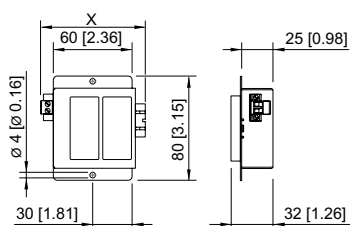

	Dimension X
with fiber optic sockets and an auxiliary power connection	81 mm [3.19]
as described above with an installed fiber optic plug	116 mm [4.57]



- For operation of up to four inherently safe fiber optic cables "op is" according to IEC 60079-28
- For 100 Mbit/s Industrial Ethernet
- Transmission range up to 3.1 mi / 5 km (multi-mode) or up to 18.6 mi / 30 km (single-mode)
- Extended temperature range -22 ... +158 °F / -30 ... +70 °C
- Redundant supply
- Installation in Cl. I, Div. 2, Zone 2 or in the safe area

WebCode **9721B**



The 9721 unmanaged switch is designed for linking electrical Ethernet networks (TX) and fiber optic (FX) based networks. The fiber optics are used for operation in hazardous areas of Cl. I, II, III, Div. 1 and Zone 0, 1, 2, 20, 21 and 22 with the type of protection "Ex op is" (IEC/EN 60079-28). Therefore, conventional fiber optic cables can also be used in hazardous areas and may be connected and disconnected during operation (hot swap). The unmanaged switch has 2 TX ports and 4 FX op is ports. Redundant supply can be provided. Compatible with: Remote I/O IS1+, HMI Series ET/MT-xx6-A-FX and ET/MT-4x8, as well as for IP network cameras.

	NEC® 500 CEC Appendix J					
	Class I		Class II		Class III	
Division	1	2	1	2	1	2
Ex interface	•	•	•	•	•	•
Installation in		•				

	CEC Section 18 NEC® 505 NEC® 506					
	Class I					
Zone	0	1	2	20	21	22
Ex interface	•	•	•	•	•	•
Installation in			•			

	IECEX / ATEX					
	Zone	0	1	2	20	21
Ex interface	•	•	•	•	•	•
Installation in			•			•

Selection Table						
Product variant	Unmanaged Switch FX op is / TX SC					
FO fiber type	FO transmission distance	Interface 1	Interface 2	Product Type	Art. No.	Weight lb
Multi-mode	3.1 mi / 5 km [OM3, OM4] 2.8 mi / 4 km [OM1]	4 Port, 100 Base-FX MM SC	2 Port, 100 Base-TX Cu, RJ45	9721/13-42-14	243427	1.1
Multi-mode/single-mode	18.6 mi / 30 km [OS1, OS2] 3.1 mi / 5 km [OM3, OM4] 2.8 mi / 4 km [OM1]	4 Port, 100 Base-FX SM/MM SC, 1 (SM) and 3 (MM)	2 Port, 100 Base-TX Cu, RJ45	9721/13-42-74	243429	1.1
Single-mode	18.6 mi / 30 km [OS1, OS2]	4 Port, 100 Base-FX SM SC	2 Port, 100 Base-TX Cu, RJ45	9721/13-42-54	243428	1.1

Single-mode version is not suitable for direct connection to Remote I/O IS1+.

Technical Data	
Explosion Protection	
USA certificate FM	FM17US0054X
CAN certificate FM	FM17CA0030X
USA marking FM	Class I, Div. 2, Groups A,B,C,D; Class I, Zone 2, AEx nA [op is] IIC T4 Gc; Ta = -30°C to +70°C; See Doc. 9721 6 031 001 1

Technical Data

Explosion Protection

CAN marking FM	Class I, Div. 2, Groups A,B,C,D; Class I, Zone 2, Ex nA [op is] IIC T4 Gc; Ta = -30°C to +70°C; See Doc. 9721 6 031 001 1
IECEX gas explosion protection	Ex nA [op is T6 Ga] IIC T4 Gc
IECEX dust explosion protection	[Ex op is Da] IIIC
Certificates	ATEX (TUR), Canada (FM), EAC (Sertium), IECEX (TUR), India (PESO), USA (FM)

Electrical Data

Connection Ethernet Interface	RJ 45 plug connector
Transfer rate	10/100 Mbit/s Auto-negotiation
Operating mode	Half duplex, Full duplex Auto-MDI(X)

Auxiliary Power

Max. power consumption	6.4 W
Nominal voltage V_{nom}	24 V DC
Polarity reversal protection	Yes
Current consumption max.	500 mA

Ambient Conditions

Ambient temperature °F	-22°F ... +158°F
Ambient temperature °C	-30 °C ... +70 °C

Mechanical Data

Degree of protection (IP)	IP20
Enclosure material	Stainless steel, powder-coated

Mounting / Installation

Mounting type	On 35 mm DIN rail
---------------	-------------------

Optical Interfaces see page 335

Accessories

Figure	Description	Art. No.	Weight lb
	Patch cable for connection of IS1+ Ethernet CPU 9441 with media converter 9721; plug LC / SC; length 3.8 ft / 3 m	220911 ▲	-

Dimensional Drawings (All Dimensions in mm [inches]) – Subject to Alterations

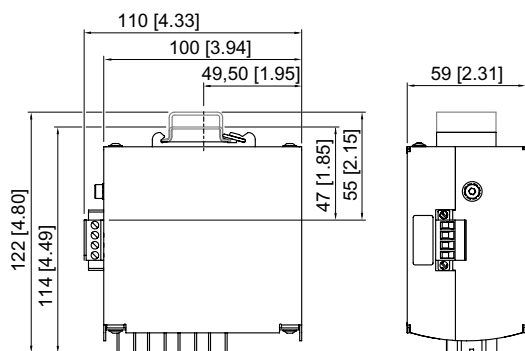

Media Converter Series 9721

Optical interfaces					
Product Type	FO fiber type	FO connection type	FO wavelength	FO fiber cross-section	FO transmission distance
9721/13-11-14	Multi-mode	SC plug connector	1310 nm	50/125 µm [OS3, OS4] 62.5/125 µm [OM1]	3.1 mi / 5 km [OM3, OM4] 2.8 mi / 4 km [OM1]
9721/13-11-54	Single-mode	SC plug connector	1300 nm	9/125 µm [OS1, OS2]	3.1 mi / 5 km [OM3, OM4] 2.8 mi / 4 km [OM1]

Unmanaged Switch Series 9721

Optical interfaces					
Product Type	FO fiber type	FO connection type	FO wavelength	FO fiber cross-section	FO transmission distance
9721/13-42-14	Multi-mode	SC plug connector	1310 nm	50/125 µm [OS3, OS4] 62.5/125 µm [OM1]	3.1 mi / 5 km [OM3, OM4] 2.8 mi / 4 km [OM1]
9721/13-42-54	Single-mode	SC plug connector	1300 nm	9/125 µm [OS1, OS2]	18.6 mi / 30 km [OS1, OS2]
9721/13-42-74	Multi-mode/single-mode	SC plug connector	1310 nm 1300 nm	50/125 µm [OS3, OS4] 62.5/125 µm [OM1] 9/125 µm [OS1, OS2]	18.6 mi / 30 km [OS1, OS2] 3.1 mi / 5 km [OM3, OM4] 2.8 mi / 4 km [OM1]



- Simple, front-end parameterization
- Bit refresh function improves signal quality
- Adjustable transmission speeds of 1.2 kbit/s and 1.5 Mbit/s - automatic with PROFIBUS DP
- Intrinsically Safe field interface for RS-485

WebCode **9185A**



9185/11 series fieldbus isolating repeaters are the interface between intrinsically safe and non-intrinsically safe PROFIBUS DP segments, Modbus RTU segments and other similar fieldbus segments. These devices galvanically separate intrinsically safe bus interfaces (RS-422/RS-485) from non-intrinsically safe interfaces (RS-232, RS-422 or RS-485).

	NEC [®] 500 CEC Appendix J					
	Class I		Class II		Class III	
Division	1	2	1	2	1	2
Ex interface	•	•	•	•	•	•
Installation in		•				

	CEC Section 18					
	NEC [®] 505 Class I			NEC [®] 506		
Zone	0	1	2	20	21	22
Ex interface		•	•			
Installation in			•			

	IECEX / ATEX					
	Zone	0	1	2	20	21
Ex interface		•	•		•	•
Installation in			•			•





Selection Table

Product Description	Fieldbus isolating repeater ISpac			
Field side of interfaces	Safe interface area	Product Type	Art. No.	Weight lb
RS-485 IS (PNO)	RS 232, RS 422, RS 485	9185/11-35-10s	227598	0.77

Technical Data

Variant	9185/11-35-10s
Explosion Protection	
USA certificate FM	FM16US0122X
CAN certificate FM	FM16CA0067X
USA marking FM	Class I, Div. 2, Groups A,B,C,D; Class I, Zone 2, AEx nA GP IIC; AIS Class I,II,III, Div. 1, Groups A,B,C,D,E,F,G; Class I, Zone 1, [AEx ib] IIC T4 at Ta = 70°C; See Doc. 91 856 01 31 1
CAN marking FM	Class I, Div. 2, Groups A,B,C,D; Class I, Zone 2, Ex nA GP IIC; AIS Class I,II,III, Div. 1, Groups A,B,C,D,E,F,G; Class I, Zone 1, [Ex ib] IIC T4 at Ta = 70°C; See Doc. 91 856 01 31 1
IECEX gas explosion protection	Ex nA [ib Gb] IIC T4 Gc
IECEX dust explosion protection	[Ex ib Db] IIIC
Certificates	ATEX (BVS), Canada (FM), IECEX (BVS), India (PESO), USA (FM)
Ship approval	CCS, DNV GL
Electrical Data	
Connections	Sub-D socket X3, 9-pole (Interface field area)
Interface settings	Fixed transmission speed or automatic detection > 9.6 kbit/s (only with Profibus DP)

Technical Data	
Variant	9185/11-35-10s
Electrical Data	
Electrical interface data rate	1.2 kbit/s - 1.5 Mbit/s
Auxiliary Power	
Auxiliary power	24 V AC / DC

Accessories				
Figure	Description	Product Type	Art. No.	Weight lb
Cable for PROFIBUS DP, RS 485, RS485-IS				
	Cable type: BUS 4000-C-PE 2x0,64mm 02YS(St) CY2Y Color (sheath): black Application area: Outdoor Installation outdoors and directly in the ground, UV-resistant	02Y(ST)CY2Y	105444	0.66
Cable for PROFIBUS DP, RS485-IS				
	Cable type: 02YS(St) CHSH Color (sheath): blue Application area: Offshore Halogen-free, steel wire braid armored cable	02YS(ST)CHSH Profibus	105400	-
	Cable type: BUS 4000-C-PVC 2x0,64mm 02YS(St) CY Color (sheath): blue Application area: Indoor Standard type for indoor installation	02Y(ST)CY	105437	-
SUB-D socket				
	9-pin for connection of the fieldbus or ServiceBus to the CPU & power module Series 9440/22 and fieldbus-isolating repeater 9185. Integrated terminator can be switched on or off. For RS 485 IS to PNO standard.	-	162693 ▲	0.22
Sub-D plug, angled				
	9-pin, for connection of fieldbus or ServiceBus to CPU & Power Module Type 9440/12 and fieldbus isolating repeater Type 9185. The termination resistance is built-in. Suitable for RS-485 IS (PNO standard).	-	201805	0.11

Dimensional Drawings see page 217



- Simple, front-end parameterization
- Bit refresh function improves signal quality
- Adjustable transmission speeds of 1.2 kbit/s and 1.5 Mbit/s - automatic with PROFIBUS DP
- Field interface non-Ex i

WebCode **9185B**



The 9185/12 series fieldbus isolating repeater can be used for the galvanically separated transmission of communication signals. It prevents any compensating currents and protects easily damaged terminal equipment from transient coupling, thereby ensuring undisturbed signal transmission for R. STAHL PROFIBUS DP, Modbus RTU and service bus. The RS-232 interface allows a PC to be connected.

	NEC [®] 500 CEC Appendix J					
	Class I		Class II		Class III	
Division	1	2	1	2	1	2
Ex interface		•		•		
Installation in		•				

	CEC Section 18					
	NEC [®] 505 Class I			NEC [®] 506		
Zone	0	1	2	20	21	22
Ex interface			•			
Installation in			•			





	IECEX / ATEX					
	Zone	0	1	2	20	21
Ex interface			•		•	•
Installation in			•			•

11

Selection Table				
Product Description	Fieldbus isolating repeater ISpac			
Field side of interfaces	Safe interface area	Product Type	Art. No.	Weight lb
RS 485 / RS 422 (switchable)	RS 232, RS 422, RS 485	9185/12-45-10s	227600	0.77

Technical Data	
Explosion Protection	
USA certificate FM	FM16US0122X
CAN certificate FM	FM16CA0067X
USA marking FM	Class I, Div. 2, Groups A,B,C,D; Class I, Zone 2, AEx nA IIC; T4 at Ta = 70°C; See Doc. 91 856 01 31 1
CAN marking FM	Class I, Div. 2, Groups A,B,C,D; Class I, Zone 2, Ex nA IIC; T4 at Ta = 70°C; See Doc. 91 856 01 31 1
IECEX gas explosion protection	Ex nA IIC T4 Gc
Certificates	ATEX (BVS), Canada (FM), IECEX (BVS), India (PESO), USA (FM)
Ship approval	CCS, DNV GL
Electrical Data	
Interface field area level	EIA RS 485, EIA RS 422
Connections	Sub-D socket X3, 9-pole (Interface field area)
Interface settings	Fixed transmission speed or automatic detection > 9.6 kbit/s (only with Profibus DP)
Line length interface field area	Depends on transmission rate and cable
Data transmission indication	LED green "Rx/D2"
Electrical interface data rate	1.2 kbit/s - 1.5 Mbit/s

Technical Data	
Electrical Data	
Terminating resistor interface field area	to be set in external plug
Auxiliary Power	
Auxiliary power	24 V AC / DC
Nominal current	66 mA

Accessories				
Figure	Description	Product Type	Art. No.	Weight lb
Cable for PROFIBUS DP, RS 485, RS485-IS				
	Cable type: BUS 4000-C-PE 2x0,64mm 02YS(St) CY2Y Color (sheath): black Application area: Outdoor Installation outdoors and directly in the ground, UV-resistant	02Y(ST)CY2Y	105444	0.66
Cable for PROFIBUS DP, RS485-IS				
	Cable type: 02YS(St) CHSH Color (sheath): blue Application area: Offshore Halogen-free, steel wire braid armored cable	02YS(ST)CHSH Profibus	105400	-
	Cable type: BUS 4000-C-PVC 2x0,64mm 02YS(St) CY Color (sheath): blue Application area: Indoor Standard type for indoor installation	02Y(ST)CY	105437	-
Sub-D plug + PG interface				
	9-pin for connection of the fieldbus or ServiceBus to the CPU & power module Series 9440/15 and fieldbus-isolating repeater 9185. Integrated terminator can be switched on or off. For non-intrinsically safe RS-485.	-	105715 ▲	-

Dimensional Drawings see page 217

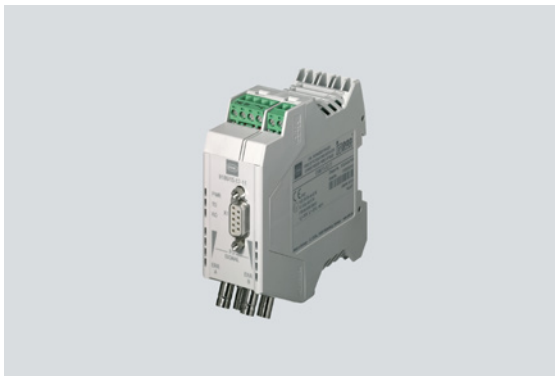

- For redundant FO network structures (PROFIBUS DP, Modbus RTU) in Cl. I, Div. 2 and Zone 2 hazardous areas
- "Ex op is" interface make for easy installation and maintenance
- Diagnostic function for early error detection and signalling

WebCode **9186B**



The 9186 series FO fieldbus isolating repeater transmits PROFIBUS DP and Modbus RTU signals over distances of up to 1.2 mi / 2 km as part of redundant fiber optic network structures. Standard plug connectors can be connected to the inherently safe optical interfaces "Ex op is". The diagnostic functions detect critical signal conditions early and report them to the control room.

	NEC® 500 CEC Appendix J					
	Class I		Class II		Class III	
Division	1	2	1	2	1	2
Ex interface		•		•		•
Installation in		•				

	CEC Section 18					
	NEC® 505 Class I			NEC® 506		
Zone	0	1	2	20	21	22
Ex interface			•			
Installation in			•			

	IECEX / ATEX					
	Zone	0	1	2	20	21
Ex interface			•			•
Installation in			•			•

11

Selection Table			
Installation	Cl. I, Div. 2; Cl. I, Zone 2; Zone 2 or safe area		
Network structure	Product Type	Art. No.	Weight lb
Line Ring Point-to-point	9186/15-12-11	160624	0.54
Point-to-point End of line	9186/25-12-11	160625	0.54







Technical Data	
Explosion Protection	
USA/CAN certificate UL	E81680_ML000
USA marking UL	Class I, Zone 2, AEx nC IIC
CAN marking UL	Class I, Zone 2, Ex nC IIC
IECEX gas explosion protection	Ex nA nC [op is T6 Ga] IIC T4 Gc
IECEX dust explosion protection	[Ex op is Da] IIIC
Certificates	ATEX (BVS), Brazil (ULB), Canada / USA (UL), IECEX (BVS), India (PESO)
Ship approval	ABS, CCS, ClassNK, DNV GL
Electrical Data	
Electrical interface data rate	9.6 kbit/s - 1.5 Mbit/s
Protocols	HART Modbus PROFIBUS DP ServiceBus R.STAHL (IS1)
Electrical interface version	RS 485

Fiber Optics Fieldbus Isolating Repeater

Series 9186/.5 for Use in Class I, Div. 2 and Zone 2

STAHL

Technical Data	
Electrical Data	
Connection electrical interfaces	Sub-D socket X1, 9-pole
Protocols optical interface	Protocol transparent for RS-485 interface
Connection optical interface	ST®, BFOC/2.5 socket
FO wavelength	850 nm
Transmission distance optical Interface	≤ 2000 m
Fault control	Power supply failure: Fault-contact is open Transmission level is good: LED green and yellow "FO signal", fault-contact is closed. Transmission level reduced (-1,5 dBm): LED yellow "FO ERR", fault-contact is open. Fiber breakage or transmission level is too low (-3 dBm): LED red "FO ERR", fault-contact is open.
Auxiliary Power	
Auxiliary power	24 V DC

Accessories				
Figure	Description	Product Type	Art. No.	Weight lb
Cable for PROFIBUS DP, RS 485, RS485-IS				
	Cable type: BUS 4000-C-PE 2x0,64mm 02YS(St) CY2Y Color (sheath): black Application area: Outdoor Installation outdoors and directly in the ground, UV-resistant	O2Y(ST)CY2Y	105444	0.66
Cable for PROFIBUS DP, RS485				
	Cable type: 02YS(St) CHSH Color (sheath): violet Application area: Offshore Halogen-free, steel wire braid armored cable	02YS(ST)CHSH ProfibusDP	209430	-
	Cable type: BUS 4000-C-PVC 2x0,64mm 02YS(St) CY Color (sheath): violet Application area: Indoor Standard type for indoor installation	O2Y(ST)CY	105438	0.66
Cable for PROFIBUS DP, RS485-IS				
	Cable type: 02YS(St) CHSH Color (sheath): blue Application area: Offshore Halogen-free, steel wire braid armored cable	02YS(ST)CHSH Profibus	105400	-
	Cable type: BUS 4000-C-PVC 2x0,64mm 02YS(St) CY Color (sheath): blue Application area: Indoor Standard type for indoor installation	O2Y(ST)CY	105437	-
Sub-D plug + PG interface				
	9-pin for connection of the fieldbus or ServiceBus to the CPU & power module Series 9440/15 and fieldbus-isolating repeater 9185. Integrated terminator can be switched on or off. For non-intrinsically safe RS-485.	-	105715 ▲	-

11

Dimensional Drawings (All Dimensions in mm [inches]) – Subject to Alterations

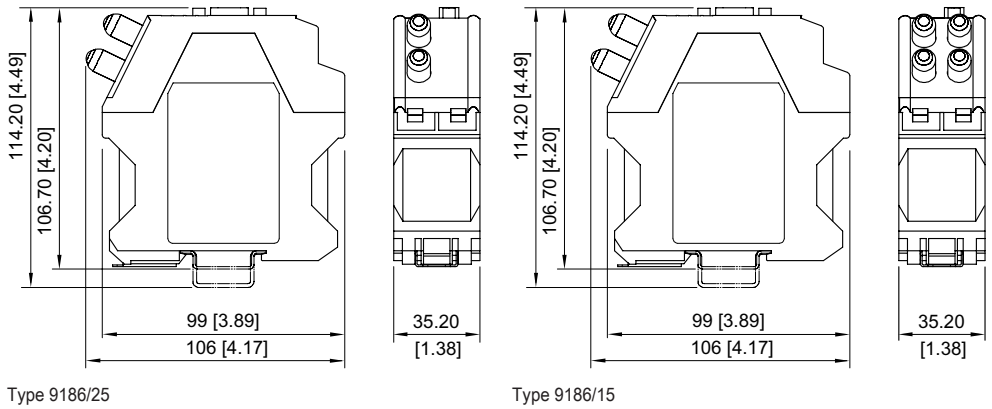



ADDITIONAL TECHNOLOGY AND SIGNALING



Product	Series	Page	WebCode
Audible and Visual Signaling Devices			
Combined Audible and Visual Signaling Devices - Flameproof Version; max. 110 dB(A) @ 1 m (39.37") / 5 J	YL60	345	YL60A
Audible Signaling Devices			
Audible Signaling Devices - Flameproof Version; max. 110 dB(A) @ 1 m (39.37")	YA60	352	YA60A
Audible Signaling Devices - Flameproof Version; max. 115 dB(A) @ 1 m (39.37")	YA90	349	YA90A
Audible Signaling Devices max. 100 dB(A) @ 1 m (39.37")	YA11	355	YA11A
Visual Signaling Devices			
Visual Signaling Devices - Flameproof Version; Xenon 5 J	FL60	358	FL60B
Terminal Boxes			
Terminal Boxes Ex e made of Moulded Material	8146/1	362	8146S
Terminal Boxes Ex i made of Moulded Material	8146/2	364	8146T
Terminal Boxes Ex e made of Stainless Steel	8150/1	367	8150L
Terminal Boxes Ex i made of Stainless Steel	8150/2	369	8150M
Maximum Number of Openings, Hubs or Cable Glands			
Terminal Boxes Series 8146 Installation of 8166/11 Conduit Hubs or Cable Glands		366	
Terminal Boxes Series 8150 Maximum Number of Holes for NPT Openings		371	

For additional products and information please refer to r-stahl.com



- Ex d enclosure made from seawater-resistant aluminium
- Omnidirectional high output sounder 110 dB(A) @ 1 m (39.37")
- 5 Joule xenon strobe
- Flash rate 1 Hz
- 2 stage alarm, independently selectable 2nd stage, each with 32 selectable tones in accordance with international regulations
- Independent tone selection using a DIL switch
- Aluminium enclosure with stainless steel fasteners
- Telephone initiate option available
- NEMA 4X / IP66 rated
- Devices have triple listing, UL, ATEX & IECEx

WebCode **YL60A**



Yodalex range

Product Series YL60 is designed to provide both an audible and visual alarm which can be used to alert, warn or draw attention to machine malfunction/start up or any number of safety related issues in hazardous areas. The audible and visual signals can be operated independently or as a combination unit.

	NEC® 500 CEC Appendix J					
	Class I		Class II		Class III	
Division	1	2	1	2	1	2
Ex interface						
Installation in	•	•	•	•	•	

	CEC Section 18 NEC® 505 NEC® 506					
	Class I					
Zone	0	1	2	20	21	22
Ex interface						
Installation in		•	•		•	•

	IECEx / ATEX					
	Zone	0	1	2	20	21
Ex interface						
Installation in		•	•		•	•

12

Selection Table						
Certificates ATEX (BAS), Canada / USA (UL), IECEx (BAS)						
Rated operational voltage AC	Rated operational voltage DC	Rated operational current	Lens colour	Product Type	Art. No.	Weight lb
115 V	-	200 mA	Amber	YL60/B/L50/A/UL	205568	13.23
		200 mA	Blue	YL60/B/L50/B/UL	205298	13.23
		200 mA	Clear	YL60/B/L50/C/UL	224224	13.23
		200 mA	Green	YL60/B/L50/G/UL	239987	13.23
		200 mA	Red	YL60/B/L50/R/UL	205299	13.23
		200 mA	Yellow	YL60/B/L50/Y/UL	211815	13.23
		230 V	-	100 mA	Amber	YL60/B/N50/A/UL
100 mA	Blue			YL60/B/N50/B/UL	272618	13.23
100 mA	Clear			YL60/B/N50/C/UL	250450	13.23
100 mA	Green			YL60/B/N50/G/UL	209044	13.23
100 mA	Red			YL60/B/N50/R/UL	212386	13.23
100 mA	Yellow			YL60/B/N50/Y/UL	224680	13.23
-	24 V			570 mA	Amber	YL60/B/D50/A/UL
		570 mA	Blue	YL60/B/D50/B/UL	205289	13.23
		570 mA	Clear	YL60/B/D50/C/UL	205291	13.23
		570 mA	Green	YL60/B/D50/G/UL	214636	13.23
		570 mA	Red	YL60/B/D50/R/UL	205293	13.23
		570 mA	Yellow	YL60/B/D50/Y/UL	205297	13.23

Technical Data

Explosion Protection

USA gas certificate	UL E161818
USA dust certificate	UL E161818
CAN gas certificate	UL E161818
CAN dust certificate	UL E161818
USA marking UL	Class I, Div. 1, Groups B,C,D; Div. 2, Groups B,C,D Class II, Groups E,F,G Class III Class I, Zone 1 AEx d IIB + H ₂ and Ex d IIB + H ₂
CAN marking UL	Class I, Div. 1, Groups B,C,D; Div. 2, Groups B,C,D Class II, Groups E,F,G Class III Class I, Zone 1, Ex d IIB + H ₂
IECEX gas explosion protection	Ex d IIB+H ₂ T4 Gb
IECEX dust explosion protection	Ex tb IIIC T135 °C Db

Acoustic Data

Sound pressure level	max. 110 dB(A) @ 39.37 "
Sound pressure level	max. 110 dB(A) @ 1 m
Tone selection	Via DIL switch
Number of stages	2

Ambient Conditions

Ambient temperature °F	-4°F ... +140°F
Ambient temperature °C	-20 °C ... +60 °C
Notes	The operating temperature is different based by the UL and IECEx certificate

Lighting Data

Lamp	Xenon flash tubes
Flash energy	5 J
Flash rate	1 Hz

Mechanical Data

Degree of protection (NEC UL 50)	NEMA 4X
Degree of protection IP (IEC 60529)	IP66
Enclosure material	Aluminum, powder-coated, Seawater-resistant
Enclosure colour	Red (RAL 3001)
Trumpet material	ABS, flame retardant
Material glas dome	Polycarbonate
Material wire guard	Stainless steel
Connection terminals solid AWG max.	AWG 14
Connection terminals solid max.	2.5 mm ²
Connection terminals finely-stranded AWG max.	AWG 14
Connection terminals finely-stranded max.	2.5 mm ²

Mounting / Installation

Connection type	Screw terminal
Material mounting parts	Sheet steel, powder-coated

Technical Data	
Components	
Drilled holes	2 x M20
Cable entries	Can be ordered as accessories
Stopping plug	1 x 1/2" NPT 2 x adapters M20x1/2"NPT 1 x dust cap
Stopping plug material	Brass
You can find more technical data online at r-stahl.com. WebCode YL60A	
Sheet steel mounting bracket supplied as standard.	

Dimensional Drawings (All Dimensions in mm [inches]) – Subject to Alterations

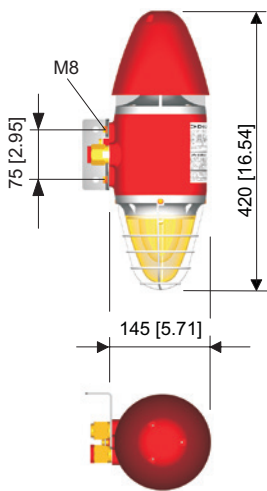

Accessories				
Figure	Description	Art. No.	Weight lb	
Mounting bracket				
	Stainless steel bracket fixing kit accessories	210794	0.88 lb	

Spare Parts				
Figure	Description	Product Type	Art. No.	Weight lb
Moulding-lens				
	clear	-	209402	0.15 lb
	red	-	209405	0.15 lb
	yellow	-	209406	0.15 lb
	amber	-	209400	0.15 lb
	blue	-	209401	0.15 lb
	green	-	209403	0.15 lb
	opal	-	209404	0.15 lb

Spare Parts				
Figure	Description	Product Type	Art. No.	Weight lb
Emergency light flange				
	amber UL spare	-	209421	2.38 lb
	blue UL spare	-	209422	2.38 lb
	clear UL spare	-	209423	2.38 lb
	green UL spare	-	209424	2.38 lb
	opal UL spare	-	209425	2.38 lb
	red UL spare	-	209426	2.38 lb
	yellow UL spare	-	209427	2.38 lb
Replacement PCB assembly				
	115 ... 230 V AC / 5 J	YL60	209522	0.86 lb
	24 V DC / 5 J	YL60	222970	0.28 lb



- Corrosion-resistant, GRP Ex d enclosure
- Max sound output 115 dB(A) @ 1 m (39.37")
- 2 stage alarm, independently selectable 2nd stage, each with 32 selectable tones in accordance with international regulations
- Independent tone selection using a DIL switch
- NEMA 4X / IP66 rated
- Monitoring facility (DC voltages only)
- Adjustable stainless steel ratchet bracket providing positive setting

WebCode **YA90A**



Yodalex range

Directional audible signal designed for use in hazardous or harsh environments.

	NEC® 500 CEC Appendix J					
	Class I		Class II		Class III	
Division	1	2	1	2	1	2
Ex interface						
Installation in		•				

	CEC Section 18					
	NEC® 505			NEC® 506		
	Class I					
Zone	0	1	2	20	21	22
Ex interface						
Installation in						

	IECEX / ATEX					
	Zone					
Zone	0	1	2	20	21	22
Ex interface						
Installation in		•	•		•	•

Selection Table					
Certificates					
Canada / USA (UL)					
Rated operational voltage AC	Rated operational voltage DC	Rated operational current	Product Type	Art. No.	Weight lb
115 V	-	0.13 A	YA90/C-L-UL-RN-ST-00-00-00	205366	9.92
230 V	-	0.09 A	YA90/C-N-UL-RN-ST-00-00-00	212397	9.92
-	24 V	0.5 A	YA90/C-D-UL-RN-ST-00-00-00	205365	9.92

Variations in gas group, voltage and certification are available.
Tag labels can be added, please contact your local sales office for more details

Technical Data	
Explosion Protection	
USA gas certificate	UL E161818
USA dust certificate	UL E161818
CAN gas certificate	UL E161818
CAN dust certificate	UL E161818
USA marking UL	Class I, Div. 2, Groups A,B,C,D
CAN marking UL	Class I, Div. 2, Groups A,B,C,D
Acoustic Data	
Sound pressure level	max. 115 dB(A) @ 1 m
Sound pressure level	max. 110 dB(A) @ 39.37 "
Tone selection	Via DIL switch
Number of stages	2
Ambient Conditions	
Ambient temperature °F	-76°F ... +151°F



Technical Data	
Ambient Conditions	
Ambient temperature °C	-60 °C ... +66 °C
Mechanical Data	
Degree of protection (NEC UL 50)	NEMA 4X
Degree of protection IP (IEC 60529)	IP66
Enclosure material	Polyester (GRP), Glass fibre reinforced
Trumpet material	ABS, flame retardant
Enclosure colour	Red (RAL 3001)
Mounting / Installation	
Connection type	Screw terminal
Material mounting parts	1.4404 stainless steel
Components	
Drilled holes	2 x M20
Cable entries	Can be ordered as accessories
Stopping plug	1 x 1/2" NPT 1 x dust cap 2 x adapters M20x1/2"NPT
Stopping plug material	Brass

You can find more technical data online at r-stahl.com. WebCode YA90A

Accessories

Figure	Description	Art. No.	Weight lb
Sun shield			
	Fixing kit for pole mounting incl. adapter plate and screws	267720	1.81
	Sun shield YA90 incl. fixing screws	267731	3.66

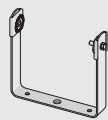
Spare Parts

Figure	Description	Art. No.	Weight lb
Mounting bracket			
	U-bracket stainless steel 1.4404	224587	0.99
Replacement PCB assembly			
	115 ... 230 V AC	209534	0.22
	24 V DC	209564	0.22

Stainless steel mounting bracket provided. Holes to suit M6, pitch 60 mm.

Dimensional Drawings (All Dimensions in mm [inches]) – Subject to Alterations

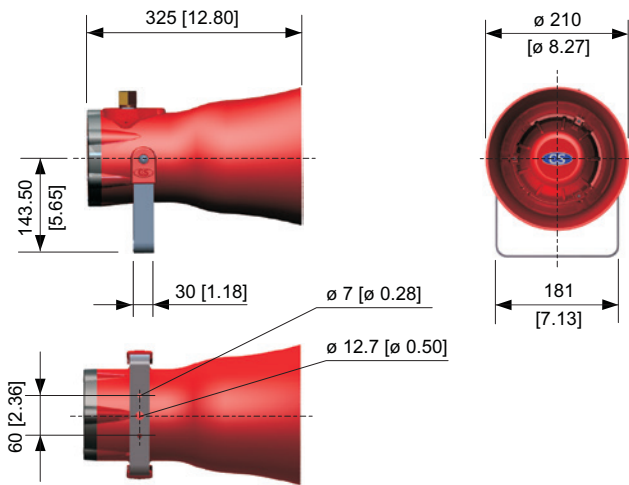



- Ex d enclosure made from seawater-resistant aluminium
- Omnidirectional high output sounder 110 dB(A) @ 1 m (39.37")
- 2 stage alarm, independently selectable 2nd stage, each with 32 selectable tones in accordance with international regulations
- Independent tone selection using a DIL switch
- NEMA 4X / IP66 rated
- Telephone initiate option available

WebCode **YA60A**



Yodalex range

Product Series YA60 is designed to provide an audible alarm which can be used to alert, warn or draw attention to machine malfunction/start up or any number of safety related issues in hazardous areas. Omnidirectional audible signal designed for use in hazardous or harsh environments.

	NEC [®] 500 CEC Appendix J					
	Class I		Class II		Class III	
Division	1	2	1	2	1	2
Ex interface						
Installation in	•	•	•	•	•	•

	CEC Section 18					
	NEC [®] 505 Class I			NEC [®] 506		
Zone	0	1	2	20	21	22
Ex interface						
Installation in		•	•		•	•

	IECEX / ATEX					
	Zone	0	1	2	20	21
Ex interface						
Installation in		•	•		•	•

12

Selection Table						
Certificates ATEX (BAS), Canada / USA (UL), IECEX (BAS)						
Rated operational voltage AC	Rated operational voltage DC	Rated operational current	Product Type	Art. No.	Weight lb	
115 V	-	0.11 A	YA60/B/L/UL	205204	11.9	
230 V	-	0.055 A	YA60/B/N/UL	207054	11.9	
-	24 V	0.35 A	YA60/B/D/UL	205202	11.9	

Further variations in gas group and voltage are available, please use the selection table on the internet at r-stahl.com. WebCode YA60A

Technical Data	
Explosion Protection	
USA gas certificate	UL E161818
USA dust certificate	UL E161818
CAN gas certificate	UL E161818
CAN dust certificate	UL E161818
USA marking UL	Class I, Div. 1, Groups B,C,D; Div. 2, Groups B,C,D; Class II Groups E,F,G Class III Class I, Zone 1, AEx d IIB + H ₂ and Ex d IIB + H ₂
CAN marking UL	Class I, Div. 1, Groups B,C,D; Div. 2, Groups B,C,D; Class II Groups E,F,G Class III Class I, Zone 1, Ex d IIB + H ₂
IECEX gas explosion protection	Ex d IIB+H ₂ T4 Gb
IECEX dust explosion protection	Ex tb IIIC T135 °C Db

Technical Data	
Acoustic Data	
Sound pressure level	max. 110 dB(A) @ 39.37 "
Sound pressure level	max. 110 dB(A) @ 1 m
Tone selection	Via DIL switch
Number of stages	2
Ambient Conditions	
Ambient temperature °F	-4°F ... +140°F
Ambient temperature °C	-20 °C ... +60 °C
Notes	The operating temperature is different based by the UL and IECEx certificate
Mechanical Data	
Degree of protection (NEC UL 50)	NEMA 4X
Degree of protection IP (IEC 60529)	IP66
Enclosure material	Aluminum, powder-coated, Seawater-resistant
Trumpet material	ABS, flame retardant
Connection terminals solid AWG max.	AWG 14
Connection terminals solid max.	2.5 mm ²
Connection terminals finely-stranded AWG max.	AWG 14
Connection terminals finely-stranded max.	2.5 mm ²
Enclosure colour	Red (RAL 3001)
Mounting / Installation	
Connection type	Screw terminal
Material mounting parts	Sheet steel, powder-coated
Components	
Drilled holes	2 x M20
Cable entries	Can be ordered as accessories
Stopping plug	1 x 1/2" NPT 1 x dust cap 2 x adapters M20x1/2"NPT
Stopping plug material	Brass
You can find more technical data online at r-stahl.com . WebCode YA60A	

Accessories			
Figure	Description	Art. No.	Weight lb
Mounting bracket			
	Stainless steel bracket fixing kit accessories	210794	0.88

Spare Parts				
Figure	Description	Product Type	Art. No.	Weight lb
Replacement PCB assembly				
	115 ... 230 V AC	YA60	209515	0.22
	24 V DC	YA60	222969	0.14

Sheet steel mounting bracket supplied as standard.

Dimensional Drawings (All Dimensions in mm [inches]) – Subject to Alterations

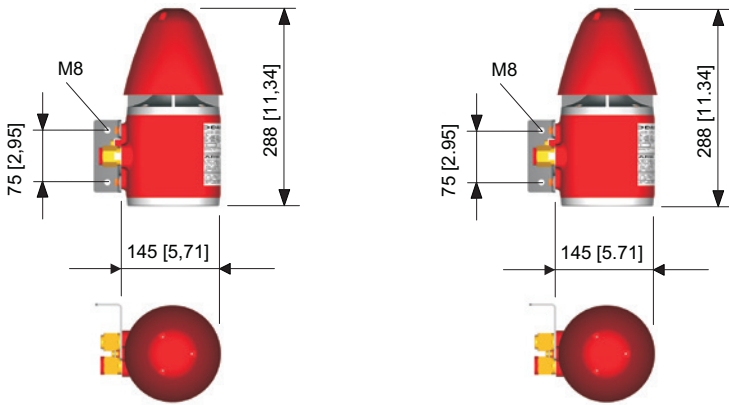



- Max. sound output 100 dB(A) @ 1 m (39.37")
- Single stage alarm
- 32 sound tones available meeting international regulations
- Low profile (28 mm/1.1") light weight aluminium enclosure
- 3 metre (118") 2 core pre wired cable fitted and prepared ready for installation
- Panel sealing gasket and fixings provided
- Low current consumption
- High performance red paint finish as standard
- NEMA 4X / IP66 rated
- Compact and lightweight design

WebCode YA11A



Yodalex range

Panel mount audible signal designed for use in hazardous or harsh environments

	NEC® 500 CEC Appendix J					
	Class I		Class II		Class III	
Division	1	2	1	2	1	2
Ex interface						
Installation in		•				

	CEC Section 18					
	NEC® 505 Class I			NEC® 506		
Zone	0	1	2	20	21	22
Ex interface						
Installation in						

	IECEX / ATEX					
	Zone	0	1	2	20	21
Ex interface						
Installation in			•			•

Selection Table				
Certificates	ATEX (BAS), Canada / USA (UL), IECEX (BAS)			
Rated operational voltage DC	Rated operational current	Product Type	Art. No.	Weight lb
24 V	0.071 A	YA11/1-D-...-RN	211439	3.31

The customer must specify the desired tone when ordering.
 The tone cannot be changed by the customer.
 32 tones are available; see order number addition on page 357, e.g. if tone 18 is desired, please use the order number YA11/1-D-18-RN.
 The tone table can be found online at r-stahl.com.

Technical Data	
Explosion Protection	
USA gas certificate	UL E161818
USA dust certificate	UL E161818
CAN gas certificate	UL E161818
CAN dust certificate	UL E161818
USA marking UL	Class I, Div. 2, Groups A,B,C,D
CAN marking UL	Class I, Div. 2, Groups A,B,C,D
IECEX gas explosion protection	Ex nA IIC T4 Gc
IECEX dust explosion protection	Ex tc IIIC T90 °C Dc
Acoustic Data	
Sound pressure level	max. 100 dB(A) @ 1 m
Sound pressure level	max. 110 dB(A) @ 39.37 "
Tone selection	According to the order
Number of stages	1

Technical Data	
Ambient Conditions	
Ambient temperature °F	-40°F ... +158°F
Ambient temperature °C	-40 °C ... +70 °C
Mechanical Data	
Degree of protection IP (IEC 60529)	IP66
Enclosure material	Aluminum / ABS
Enclosure colour	Red (RAL 3001)
Cable length inches	118 in
Conductor length m	3 m
Mounting / Installation	
Material mounting parts	Stainless steel
Connection type	ÖLFLEX150 QUATTRO/18AWG 2x1mm ²

You can find more technical data online at r-stahl.com. WebCode YA11A

Spare Parts			
Figure	Description	Art. No.	Weight lb
Replacement installation kit			
	gasket, screws, nuts, locking devices and washers	212603	0.09

Dimensional Drawings (All Dimensions in mm [inches]) – Subject to Alterations

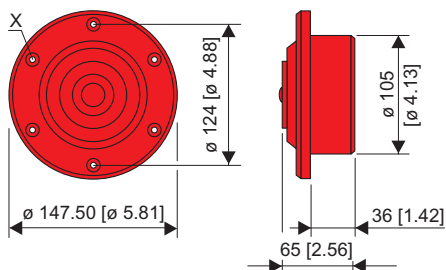

Tone Table

Tone no.	Version	Frequency	Repetition rate (sec)	Special application
Tone 01	Alternate two-tone	800-1000	0.5	Fire alarms - Level crossing
Tone 02	Alternate two-tone	2500-3100	0.5	Security alarms
Tone 03	Alternate fast two-tone	800-1000	0.25	Increased urgency - Level crossing
Tone 04	Alternate fast two-tone	2500-3100	0.25	Security deterrent
Tone 05	Alternate two-tone	440-554	0.4/0.1	AFNOR, France
Tone 06	Alternate two-tone	430-470	1.0	
Tone 07	Alternate fast two-tone	800-1000	0.13	
Tone 08	Alternate fast two-tone	2500-3200	0.07	
Tone 09	Alternate two-tone	440-554	2.0	Turn out, Sweden
Tone 10	Continuous tone	700		All-clear, Sweden
Tone 11	Continuous tone	1000		
Tone 12	Continuous tone	1000		
Tone 13	Continuous tone	2300		
Tone 14	Continuous tone	440		
Tone 15	Interrupted tone	1000	2.0	
Tone 16	Interrupted tone	420	1.25	AS2220, Australia
Tone 17	Interrupted tone	1000	0.5	
Tone 18	Interrupted tone	2500	0.25	
Tone 19	Interrupted tone	2500	0.5	
Tone 20	Interrupted tone	700	6/12	Pre-vital message, Sweden
Tone 21	Interrupted tone	1000	1.0	
Tone 22	Interrupted tone	700	4.0	Air-raid alarm, Sweden
Tone 23	Interrupted tone	700	0.25	Local warning, Sweden
Tone 24	Interrupted tone	720	0.7/0.3	Industrial alarm, Germany
Tone 25	Interrupted, fast, rising volume	1400	0.25	
Tone 26	Fast siren	250-1200	0.085	
Tone 27	Rising constant, fall	1000	10/40/10	Industrial alarm, Germany
Tone 28	ISO 8201 Evacuation	800-1000	As standard	International evacuation alarm
Tone 29	Fast whoop	500-1000	0.15	
Tone 30	Slow whoop	500-1200	4.5	Evacuation, The Netherlands
Tone 31	Reverse sweep	1200-500	1.0	Evacuation, Germany
Tone 32	Siren	500-1200	3.0	



- Ex d enclosure made from seawater-resistant aluminium
- 5 Joule xenon strobe
- Lens available in seven different colours
- Stainless steel fixings
- Flash rate 1 Hz
- Lens guard and mounting bracket supplied as standard
- NEMA 4X / IP66 rated
- Telephone initiate option available
- SIL 1 IEC61508-2:2010

WebCode **FL60B**



Yodalex range

Product Series FL60 is designed to provide a visual alarm which can be used to alert, warn or draw attention to machine malfunction/start up or any number of safety related issues in hazardous areas. Visual signal designed for use in hazardous or harsh environments.

	NEC® 500 CEC Appendix J					
	Class I		Class II		Class III	
Division	1	2	1	2	1	2
Ex interface						
Installation in	•	•	•	•	•	

	CEC Section 18					
	NEC® 505 Class I			NEC® 506		
Zone	0	1	2	20	21	22
Ex interface						
Installation in		•	•		•	•

	IECEX / ATEX					
	Zone	0	1	2	20	21
Ex interface						
Installation in		•	•		•	•

12

Selection Table							
Certificates Flash energy		ATEX (BAS), Canada / USA (UL), IECEx (BAS) 5 J					
Rated operational voltage AC	Rated operational voltage DC	Nominal current at AC	Nominal current at DC	Lens colour	Product Type	Art. No.	Weight lb
115 V	-	0.09 A	-	Amber	FL60/B/L50/A/UL	205163	11.2
		0.09 A	-	Blue	FL60/B/L50/B/UL	205164	11.2
		0.09 A	-	Clear	FL60/B/L50/C/UL	261246	11.2
		0.09 A	-	Green	FL60/B/L50/G/UL	269204	11.2
		0.09 A	-	Red	FL60/B/L50/R/UL	205165	11.2
230 V	-	0.045 A	-	Amber	FL60/B/N50/A/UL	212367	11.2
		0.045 A	-	Red	FL60/B/N50/R/UL	211406	11.2
-	24 V	-	0.22 A	Amber	FL60/B/D50/A/UL	205156	11.2
		-	0.22 A	Blue	FL60/B/D50/B/UL	205368	11.2
		-	0.22 A	Clear	FL60/B/D50/C/UL	205159	11.2
		-	0.22 A	Red	FL60/B/D50/R/UL	205160	11.2
		-	0.22 A	Yellow	FL60/B/D50/Y/UL	205369	11.2

Further variations in gas group, flash energy, voltage and lens colour are available, please use the selection table on the internet. WebCode FL60B
The tone table can be found online at r-stahl.com.

Technical Data	
Explosion Protection	
CAN gas certificate	UL E188831
CAN dust certificate	UL E188831
USA gas certificate	UL E188831
USA dust certificate	UL E188831
USA marking UL	Class I, Division 1, Groups B,C,D; Division 2, Groups B,C,D Class II, Groups E,F,G Class III Class I, Zone 1 AEx d IIB + H ₂ and Ex d IIB + H ₂
CAN marking UL	Class I, Division 1, Groups B,C,D; Division 2, Groups B,C,D Class II, Groups E,F,G Class III Class I, Zone 1 Ex d IIB + H ₂
IECEX gas explosion protection	Ex d IIB+H ₂ T4 Gb
IECEX dust explosion protection	Ex tb IIIC T135 °C Db
Ambient Conditions	
Ambient temperature °F	-4°F ... +140°F
Ambient temperature °C	-20 °C ... +60 °C
Notes	The operating temperature is different based by the UL and IECEX certificate
Lighting Data	
Lamp	Xenon flash tubes
Flash rate	1 Hz
Mechanical Data	
Degree of protection (NEC UL 50)	NEMA 4X
Degree of protection IP (IEC 60529)	IP66
Protection class	I (PE connection) (Internal + external)
Enclosure material	Aluminum, powder-coated, Seawater-resistant
Material glas dome	Polycarbonate
Material wire guard	Stainless steel
Connection terminals solid AWG max.	AWG 14
Connection terminals solid max.	2.5 mm ²
Connection terminals finely-stranded AWG max.	AWG 14
Connection terminals finely-stranded max.	2.5 mm ²
Enclosure colour	Red (RAL 3001)
Mounting / Installation	
Connection type	Screw terminal
Material mounting parts	Sheet steel, powder-coated
Components	
Drilled holes	2 x M20
Cable entries	Can be ordered as accessories
Stopping plug	1 x 1/2" NPT 1 x dust cap 2 x adapters M20x1/2"NPT
Stopping plug material	Brass
You can find more technical data online at r-stahl.com . WebCode FL60B	
Sheet steel mounting bracket supplied as standard. Approvals of the cable entries must be observed.	

Dimensional Drawings (All Dimensions in mm [inches]) – Subject to Alterations

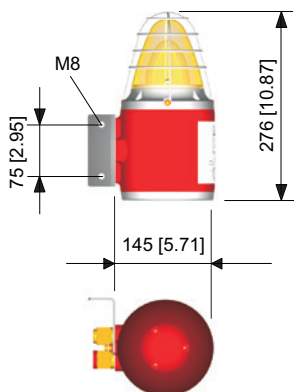

Accessories

Figure	Description	Art. No.	Weight lb
Mounting bracket			
	Stainless steel bracket fixing kit accessories	210794	0.88 lb
	material: stainless steel	262014	0.64 lb
Sun shield			
	material: stainless steel	262012	0.4 lb

Spare Parts

Figure	Description	Product Type	Art. No.	Weight lb
Moulding-lens				
	clear	-	209402	0.15 lb
	red	-	209405	0.15 lb
	yellow	-	209406	0.15 lb
	amber	-	209400	0.15 lb
	blue	-	209401	0.15 lb
	green	-	209403	0.15 lb
	opal	-	209404	0.15 lb

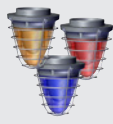
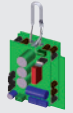
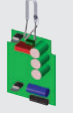
Spare Parts				
Figure	Description	Product Type	Art. No.	Weight lb
Emergency light flange				
	amber UL spare	-	209421	2.38 lb
	blue UL spare	-	209422	2.38 lb
	clear UL spare	-	209423	2.38 lb
	green UL spare	-	209424	2.38 lb
	opal UL spare	-	209425	2.38 lb
	red UL spare	-	209426	2.38 lb
	yellow UL spare	-	209427	2.38 lb
	Replacement PCB assembly			
	115 ... 230 V AC / 5 J	FL60	209503	0.22 lb
	24 V DC / 5 J	FL60	222971	0.21 lb



- Wide range of Ex e terminal boxes in various sizes and heights
- Degree of protection IP66
- Customised equipping in accordance with customer specifications
- Enclosures with captive cover screws
- If required, flange on enclosure sides is possible

WebCode **8146S**



R. STAHL Series 8146 terminal boxes, made of high-quality, glass fiber-reinforced polyester resin, are ideal for use in harsh operating conditions. With eight basic sizes in various heights, they are universally usable. If requested by the customer, they are equipped with series terminals up to 300 mm² and, as an option, a flange on several enclosure sides is possible.

	NEC [®] 500 CEC Appendix J						CEC Section 18 NEC [®] 505 NEC [®] 506						IECEX / ATEX						
	Class I		Class II		Class III		Class I			Class I			0		20		21		22
Division	1	2	1	2	1	2	0	1	2	20	21	22	0	1	2	20	21	22	
Ex interface																			
Installation in		•	•	•				•	•					•	•		•	•	

12

Selection Table							
Product Description		Ex e terminal box					
Figure	Terminal	Terminal rail	Type of grounding terminal 1	Max. no. of terminals 10 mm ² / AWG 8	Product Type	Art. No.	Weight lb
	1 x Phoenix UT 2-conductor, 10 mm ² , grey	35 x 133 mm (1x)	1 x Phoenix UT USLKG 10 N, green-yellow	10	8146/1051	278800	2.34
	1 x Phoenix UT 2-conductor, 10 mm ² , grey	35 x 189 mm (1x)	1 x Phoenix UT USLKG 10 N, green-yellow	13	8146/1061	278802	3.09
	1 x Phoenix UT 2-conductor, 10 mm ² , grey	35 x 301 mm (1x)	1 x Phoenix UT USLKG 10 N, green-yellow	24	8146/1073	278803	4.01
	1 x Phoenix UT 2-conductor, 10 mm ² , grey	35 x 301 mm (1x)	1 x Phoenix UT USLKG 10 N, green-yellow	26	8146/1083	278804	6.11

The enclosures are equipped with mounting rails, PE terminals and 1 terminal block of the specified type.

Technical Data	
Explosion Protection	
USA certificate UL	E177642V1S1
CAN certificate UL	E177642V1S1
USA marking UL	Class I, Div. 2, Groups A,B,C,D Class I, Zone 1, AEx e IIC T6,T5,T4 Class II, Div. 2, Groups F,G Class III

Technical Data	
Explosion Protection	
CAN marking UL	Class I, Div. 2, Groups A,B,C,D Class I, Zone 1, Ex e IIC T6,T5,T4 Class II, Div. 2, Groups F,G Class III
IECEX gas explosion protection	Ex eb IIC T6/T5/T4 Gb
IECEX dust explosion protection	Ex tb IIIC T80 °C ... T95 °C ... T135 °C Db
Certificates	ATEX (PTB), Brazil (ULB), China (NEPSI), EAC (LPE), IECEX (PTB), India (PESO), Korea (KGS), Taiwan (ITRI)
Ship approval	BVIS
Electrical Data	
Rated operational voltage AC NEC, CEC	600 V
Rated operational voltage AC IEC	690 V
Current carrying capacity NEC, CEC	max. 65 A
Current carrying capacity IEC	max. 54 A
Notes	Rated operational voltage max. 1100 V AC/DC (depending on terminal types and explosion-protected components used)
Ambient Conditions	
Ambient temperature °F	-58 °F ... +104 °F (T6) (T80 °C) -58 °F ... +131 °F (T5) (T95 °C) -58 °F ... +167 °F (T4) (T135 °C)
Ambient temperature °C	-50 °C ... +40 °C (T6) (T80 °C) -50 °C ... +55 °C (T5) (T95 °C) -50 °C ... +75 °C (T4) (T135 °C)
Mechanical Data	
Degree of protection (IP)	IP66
Degree of protection note	according to IEC/EN 60529
Enclosure material	Polyester resin, Glass fiber reinforced
Silicone-free	No
Components	
Notes	Please observe the information of the terminal manufacturer, e.g. the tightening torque
Max. number of conduit hubs or cable glands found on page 366	

Dimensional Drawings (All Dimensions in mm [inches]) – Subject to Alterations

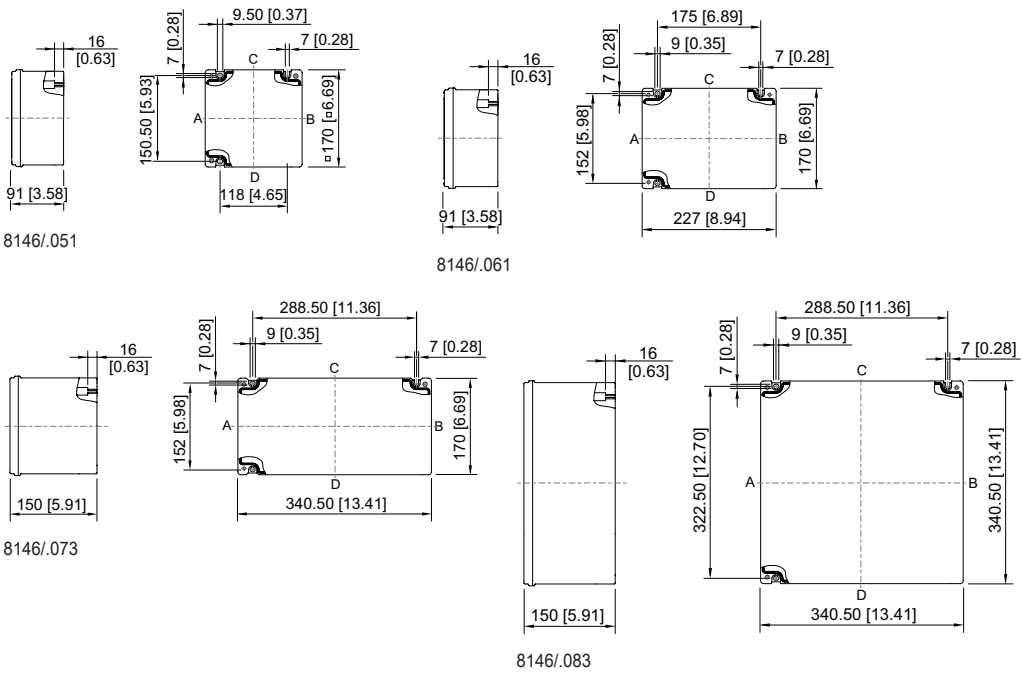



- Wide range of Ex i terminal boxes in various sizes and materials
- Degree of protection IP66
- Customised equipping in accordance with customer specifications
- Enclosures with captive cover screws
- If required, flange on enclosure sides is possible

WebCode **8146T**



R. STAHL Series 8146 terminal boxes, made of high-quality, glass fiber-reinforced polyester resin, are ideal for use in harsh operating conditions. With eight basic sizes in various heights, they are universally usable. If requested by the customer, they are equipped with series terminals up to 300 mm² and, as an option, a flange on several enclosure sides is possible.

	NEC® 500 CEC Appendix J						CEC Section 18						IECEX / ATEX					
	Class I		Class II		Class III		NEC® 505 Class I			NEC® 506			Zone		Ex interface		Installation in	
Division	1	2	1	2	1	2	0	1	2	20	21	22	0	1	2	20	21	22
Ex interface																		
Installation in	•	•	•	•	•	•		•	•		•	•		•	•		•	•

12

Selection Table							
Product Description		Ex i terminal box					
Figure	Terminal	Terminal rail	PA terminal	Max. no. of terminals 2.5 mm ² / AWG 14	Product Type	Art. No.	Weight lb
	1 x Phoenix UT 2-conductor, 2.5 mm ² , blue	35 x 133 mm (1x)	1 x Phoenix UT 2.5 mm ² grey	19	8146/2051	278806	2.2
	1 x Phoenix UT 2-conductor, 2.5 mm ² , blue	35 x 189 mm (1x)	1 x Phoenix UT 2.5 mm ² grey	27	8146/2061	278807	3.09
	1 x Phoenix UT 2-conductor, 2.5 mm ² , blue	35 x 301 mm (1x)	1 x Phoenix UT 2.5 mm ² grey	49	8146/2073	278808	4.01
	1 x Phoenix UT 2-conductor, 2.5 mm ² , blue	35 x 301 mm (1x)	1 x Phoenix UT 2.5 mm ² grey	51	8146/2083	278809	10.49

The enclosures are equipped with mounting rails, PE terminals and 1 terminal block of the specified type.

Technical Data	
Explosion Protection	
USA marking	Class I, Div. 1,2, Groups A,B,C,D; Class II, Div. 1,2, Groups E,F,G; Class I, Zone 1, Group IIC T6; Class III

Technical Data	
Explosion Protection	
CAN marking	Class I, Div. 1,2, Groups A,B,C,D; Class II, Div. 1,2, Groups E,F,G; Class I, Zone 1, Group IIC T6; Class III
IECEX gas explosion protection	Ex ia ib IIC T6 Gb
IECEX dust explosion protection	Ex tb IIIC T80 °C Db
Certificates	ATEX (PTB), Brazil (ULB), China (NEPSI), EAC (LPE), IECEX (PTB), India (PESO), Korea (KGS), Taiwan (ITRI)
Ship approval	BVIS
Electrical Data	
Rated operational voltage AC IEC	60 V
Notes	depend on the terminal type used and the explosion protected components
Ambient Conditions	
Ambient temperature °F	-58 °F ... +167 °F
Ambient temperature °C	-50 °C ... +75 °C
Mechanical Data	
Degree of protection (IP)	IP66
Degree of protection note	according to IEC/EN 60529
Enclosure material	Polyester resin, Glass fiber reinforced
Silicone-free	No
Components	
Notes	Please observe the information of the terminal manufacturer, e.g. the tightening torque

Max. number of conduit hubs or cable glands found on page 366

Dimensional Drawings (All Dimensions in mm [inches]) – Subject to Alterations

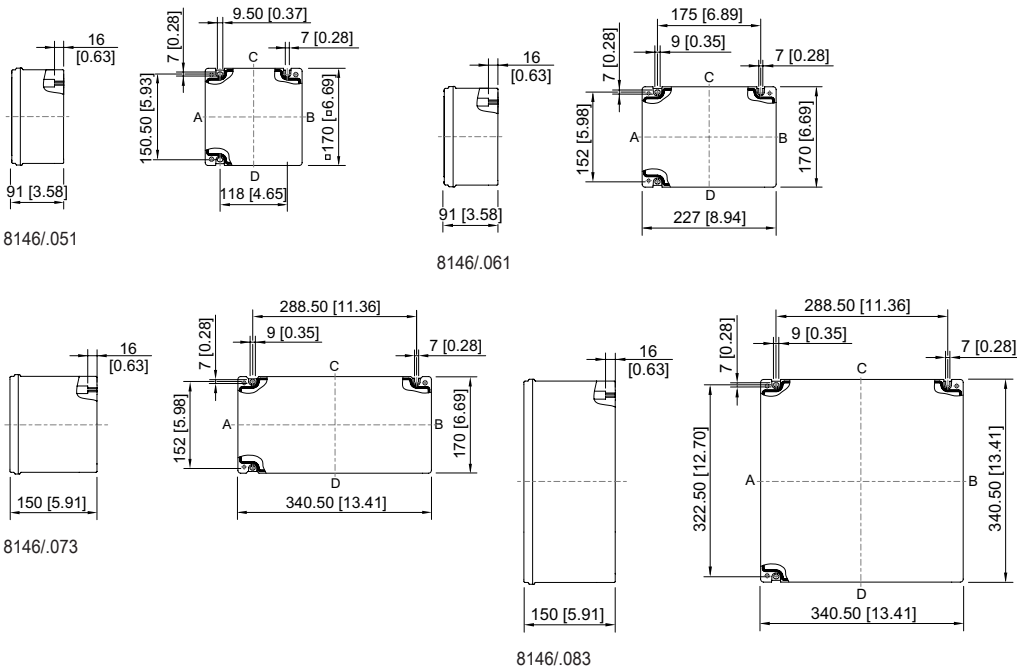

Installation of 8166/11 Conduit Hubs or Cable Glands

Table for max. numbers of entry openings either installed with conduit hubs 8166/11 or cable glands.

CAUTION:

The max. possible number of entries which can be installed on the sides of the enclosures depends on the number of terminal columns installed.

With horizontally installed columns, there are no side entries possible or only limited, depending on enclosure size.

With vertically installed columns there are no bottom or top entries possible, or only limited, depending on enclosure size. For installation with metallic glands additional reinforcement / grounding measures should be considered. Please consult factory.

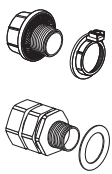
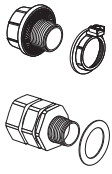
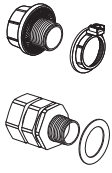
Cable gland	Enclosure size																
	8146/.031		8146/.041		8146/.051/.052				8146/.061/.062				8146/.071/.072				
																	
	without flange		without flange		without flange		with flange		without flange		with flange		without flange		with flange		
Size	A/B	C/D	A/B	C/D	A/B	C/D	A/B	C/D	A/B	C/D	A/B	C/D	A/B	C/D	A/B	C/D	
1/2"	1	1	1	2	2	3	-	2	3	4	2	2	3	6	2	4	
3/4"	1	1	1	2	1	2	-	2	2	3	2	2	2	5	2	4	
1"	-	1	1	1	1	2	-	1	2	2	1	1	2	4	1	2	
1-1/4"	-	-	1	1	1	1	-	-	1	2	-	-	1	3	-	-	
1-1/2"	-	-	-	-	-	-	-	-	-	-	-	-	-	-	-	-	
2"	-	-	-	-	-	-	-	-	-	-	-	-	-	-	-	-	
2-1/2"	-	-	-	-	-	-	-	-	-	-	-	-	-	-	-	-	
3"	-	-	-	-	-	-	-	-	-	-	-	-	-	-	-	-	
	8146/.073/.075				8146/S071				8146/.S73				8146/.081/.082				
without flange		without flange		without flange		with flange		without flange		with flange		without flange		with flange			
Size	A/B	C/D	A/B	C/D	A/B	C/D	A/B	C/D	A/B	C/D	A/B	C/D	A/B	C/D	A/B	C/D	
1/2"	6	12	4	11	2	7	-	4	5	14	-	11	6	7	4	4	
3/4"	5	9	4	9	1	6	-	4	3	12	-	9	5	6	4	4	
1"	4	8	2	4	1	4	-	2	2	8	-	4	4	4	2	2	
1-1/4"	2	5	1	4	1	4	-	-	1	5	-	4	3	4	-	-	
1-1/2"	2	4	1	3	-	-	-	-	1	4	-	3	-	-	-	-	
2"	1	3	1	2	-	-	-	-	1	3	-	2	-	-	-	-	
2-1/2"	1	2	1	2	-	-	-	-	-	3	-	2	-	-	-	-	
3"	1	2	-	-	-	-	-	-	-	2	-	-	-	-	-	-	
	8146/.083/.085/.086				8146/.091/.092				8146/.093/.095								
without flange		without flange		without flange		with flange		without flange		with flange		without flange		with flange			
Size	A/B	C/D	A/B	C/D	A/B	C/D	A/B	C/D	A/B	C/D	A/B	C/D	A/B	C/D	A/B	C/D	
1/2"	12	14	11	11	7	12	4	8	14	28	11	22					
3/4"	9	12	9	9	6	10	4	8	12	19	9	18					
1"	8	8	4	4	4	8	2	4	8	16	4	8					
1-1/4"	5	5	4	4	4	7	-	-	5	11	4	8					
1-1/2"	4	4	3	3	-	-	-	-	4	7	3	6					
2"	3	3	2	2	-	-	-	-	3	6	2	4					
2-1/2"	2	3	2	2	-	-	-	-	3	4	2	4					
3"	2	2	-	-	-	-	-	-	2	4	-	-					



- Resistant Ex e terminal boxes made of stainless steel
- Degree of protection IP66
- External earth connection M8
- Version as screw-on cover for other alternatives contact factory
- Equipped as required

WebCode 8150L



R. STAHL Series 8150 Ex e terminal boxes are made of brushed stainless steel (DIN 1.4301, ANSI 304 or DIN 1.4404, ANSI 316L) and are particularly resistant. The optimised design and the circumferential protection channel on the cover opening and the silicone seal suitable for the most extreme temperature ranges make the enclosure usable worldwide. Various optional accessories are available.

	NEC® 500 CEC Appendix J					
	Class I		Class II		Class III	
Division	1	2	1	2	1	2
Ex interface						
Installation in		•				

	CEC Section 18 NEC® 505 NEC® 506					
	Class I					
Zone	0	1	2	20	21	22
Ex interface						
Installation in		•	•			

	IECEX / ATEX					
	Zone	0	1	2	20	21
Ex interface						
Installation in		•	•		•	•

12

Selection Table								
Product Description	Ex e terminal box							
Enclosure material	DIN 1.4404 stainless steel, (ANSI 316L), brush finished							
Figure	Dimensions (WxHxD) inch	Type of terminals 1	Type of grounding terminal 1	Terminal rail	Max. no. of terminals 10 mm ² / AWG 8	Product Type	Art. No.	Weight lb
	7 x 7 x 3.6 inch	1 x Phoenix UT 2-conductor, 10 mm ² , grey	1 x Phoenix UT 2-conductor, 10 mm ² , green-yellow	35 x 133 mm (1x)	9	8150/1-0176-0176-091-3311	278810	5.6
	9.3 x 7 x 3.6 inch	1 x Phoenix UT 2-conductor, 10 mm ² , grey	1 x Phoenix UT 2-conductor, 10 mm ² , green-yellow	35 x 189 mm (1x)	13	8150/1-0236-0176-091-3311	278811	6.81
	14.2 x 7 x 5.9 inch	1 x Phoenix UT 2-conductor, 10 mm ² , grey	1 x Phoenix UT 2-conductor, 10 mm ² , green-yellow	35 x 301 mm (1x)	26	8150/1-0360-0176-150-3311	278812	7.1
	14.2 x 14.2 x 5.9 inch	1 x Phoenix UT 2-conductor, 10 mm ² , grey	1 x Phoenix UT 2-conductor, 10 mm ² , green-yellow	35 x 301 mm (1x)	26	8150/1-0360-0360-150-3311	278813	14.7

The enclosures are equipped with mounting rails and 1 terminal block of the specified type. Hinges, or quarter-turn latch on request, contact factory.

Technical Data	
Explosion Protection	
USA certificate UL	E177642V1S2

Technical Data

Explosion Protection

CAN certificate UL	E177642V1S2
USA marking UL	Class I, Div. 2, Groups A,B,C,D Class I, Zone 1, AEx e IIC T6,T5,T4
CAN marking UL	Class I, Div. 2, Groups A,B,C,D Class I, Zone 1, Ex e IIC T6,T5,T4
IECEX gas explosion protection	Ex eb IIC T6/T5/T4 Gb
IECEX dust explosion protection	Ex tb IIIC T80 °C ... T95 °C ... T135 °C Db
Certificates	ATEX (PTB), China (CQST), EAC (LPE), IECEX (PTB), India (PESO), Korea (KGS), Taiwan (ITRI)
Ship approval	GL

Electrical Data

Rated operational voltage AC NEC, CEC	600 V
Rated operational voltage AC IEC	690 V
Current carrying capacity NEC, CEC	max. 65 A
Current carrying capacity IEC	max. 54 A
Notes	depend on the terminal type used and the explosion protected components

Ambient Conditions

Ambient temperature °F	-58 °F ... +104 °F (T6) (T80 °C) -58 °F ... +131 °F (T5) (T95 °C) -58 °F ... +185 °F (T4) (T135 °C)
Ambient temperature °C	-50 °C ... +40 °C (T6) (T80 °C) -50 °C ... +55 °C (T5) (T95 °C) -50 °C ... +85 °C (T4) (T135 °C)

Mechanical Data

Degree of protection IP (IEC 60529)	IP66
Silicone-free	No
Connection cross-section	10 mm ²
Material note	special version on request

Components

Notes	Please refer to the manufacturer's terminal data, e. g. the tightening torque
-------	---

Max. number of holes for NPT openings found on page 371



- Resistant Ex i terminal boxes made of stainless steel
- Degree of protection IP66
- External earth connection M8
- Version as screw-on cover for other alternatives contact factory
- Equipped as required

WebCode **8150M**



R. STAHL Series 8150 Ex i terminal boxes are made of brushed stainless steel (DIN 1.4301, ANSI 304 or DIN 1.4404, ANSI 316L) and are particularly resistant. The optimised design and the circumferential protection channel on the cover opening and the silicone seal suitable for the most extreme temperature ranges make the enclosure usable worldwide. Various optional accessories are available.

	NEC® 500 CEC Appendix J					
	Class I		Class II		Class III	
Division	1	2	1	2	1	2
Ex interface						
Installation in	•	•	•	•	•	•

	CEC Section 18					
	NEC® 505			NEC® 506		
	Class I					
Zone	0	1	2	20	21	22
Ex interface						
Installation in		•	•		•	•

	IECEX / ATEX					
	Zone					
Zone	0	1	2	20	21	22
Ex interface						
Installation in		•	•		•	•

Selection Table								
Product Description	Ex i terminal box							
Enclosure material	DIN 1.4404 stainless steel, (ANSI 316L), brush finished							
Figure	Dimensions (WxHxD) inch	Type of terminals	1 PA terminal	Terminal rail	Max. no. of terminals 2.5 mm² / AWG 14	Product Type	Art. No.	Weight lb
	7 x 7 x 3.6 inch	1 x Phoenix UT 2-conductor, 2.5 mm², blue	1 x Phoenix UT 2.5 mm², grey	35 x 133 mm (1x)	19	8150/2-0176-0176-091-3311	278814	5.6
	9.3 x 7 x 3.6 inch	1 x Phoenix UT 2-conductor, 2.5 mm², blue	1 x Phoenix UT 2.5 mm², grey	35 x 189 mm (1x)	27	8150/2-0236-0176-091-3311	278817	6.81
	14.2 x 7 x 5.9 inch	1 x Phoenix UT 2-conductor, 2.5 mm², blue	1 x Phoenix UT 2.5 mm², grey	35 x 301 mm (1x)	52	8150/2-0360-0176-150-3311	278818	7.1
	14.2 x 14.2 x 5.9 inch	1 x Phoenix UT 2-conductor, 2.5 mm², blue	1 x Phoenix UT 2.5 mm², grey	35 x 301 mm (1x)	52	8150/2-0360-0360-150-3311	278819	14.7

The enclosures are equipped with mounting rails and 1 terminal block of the specified type. Hinges on request.

Technical Data	
Explosion Protection	
USA marking	Class I, Div. 1,2, Groups A,B,C,D; Class II, Div. 1,2, Groups E,F,G; Class I, Zone 1, Group IIC T6; Class III

Technical Data	
Explosion Protection	
CAN marking	Class I, Div. 1,2, Groups A,B,C,D; Class II, Div. 1,2, Groups E,F,G; Class I, Zone 1, Group IIC T6; Class III
IECEx gas explosion protection	Ex ia ib IIC T6 Gb
IECEx dust explosion protection	Ex tb IIIC T80 °C Db
Certificates	ATEX (PTB), China (CQST), EAC (LPE), IECEx (PTB), India (PESO), Korea (KGS), Taiwan (ITRI)
Ship approval	GL
Electrical Data	
Rated operational voltage AC IEC	60 V
Notes	depends on the terminal type used and the explosion protected components
Ambient Conditions	
Ambient temperature °F	-58 °F ... +167 °F
Ambient temperature °C	-50 °C ... +75 °C
Mechanical Data	
Degree of protection IP (IEC 60529)	IP66
Silicone-free	No
Connection cross-section	2.5 mm ²
Material note	special version on request
Components	
Notes	Please refer to the manufacturer's terminal data, e. g. the tightening torque
Max. number of holes for NPT openings found on page 371	

Maximum Number of Holes for NPT Openings

Attention:
Entry hardware as listed in selection maximum number of holes for NPT openings.

Holes for NPT openings	Enclosure size							
	8150/.-0176-116-091-.3.1		8150/.0176-0236-091-.3.1		8150/.0300-0200-150-.3.1		8150/.-0360-0176-150-.3.1	
	without flange		without flange		without flange		without flange	
Size	A/B	C/D	A/B	C/D	A/B	C/D	A/B	C/D
1/2"	3	2	4	3	12	6	7	3
3/4"	3	1	4	3	10	6	6	3
1"	2	1	3	2	8	6	5	2
1-1/4"	-	-	-	-	4	2	-	-
1-1/2"	-	-	-	-	3	2	-	-
2"	-	-	-	-	2	1	-	-
2-1/2"	-	-	-	-	2	1	-	-
3"	-	-	-	-	-	-	-	-
	8150/.-0360-0360-150-.3.1		8150/.-0400-0300-150-.3.1		8150/.-0400-0400-150-.3.1		8150/.-0600-0400-150-.3.1	
	without flange		without flange		without flange		without flange	
Size	A/B	C/D	A/B	C/D	A/B	C/D	A/B	C/D
1/2"	7	7	16	12	16	16	16	24
3/4"	6	6	14	10	14	14	14	22
1"	5	5	12	8	12	12	12	18
1-1/4"	-	-	5	4	5	5	5	8
1-1/2"	-	-	4	3	4	4	4	7
2"	-	-	4	2	4	4	4	6
2-1/2"	-	-	3	2	3	3	3	5
3"	-	-	-	-	-	-	-	-
	8150/.-0727-0360-150-.3.1							
	without flange							
Size	A/B	C/D						
1/2"	14	30						
3/4"	12	28						
1"	10	22						
1-1/4"	4	10						
1-1/2"	4	8						
2"	3	7						
2-1/2"	3	6						
3"	-	-						

CAMERA SYSTEMS – CHAPTER INDEX TABLES



Product	Series	Page	WebCode
Camera Systems – Chapter Index Tables Compact Camera, Zoom Camera, Pan-Tilt-Zoom Camera, Thermal Imaging Camera		373	

For additional products and information please refer to r-stahl.com

Camera Systems

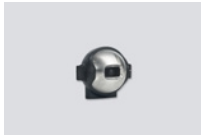

EC-710 Fix camera



EC-910 Auto Focus Zoom camera

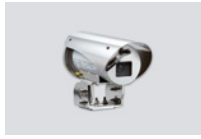

EC-940S Auto Focus Zoom camera



EC-940 Pan Tilt Zoom camera



EC-840S Thermal Imaging camera

		Haz. Area Rating				Transmission Technology		Viewing Angle			Resolution	
		Cl. I, II, III Div. 2	Zones 2, 22	Zones 1, 21	Cl. II, III Div. 1	Analog	IP Ethernet	23°	44°	81°		
Compact Camera	EC-710-023P-CSA-C1D2	X	X	X	X	X		X			470 TVL	Page 377
	EC-710-044P-CSA-C1D2	X	X	X	X	X			X		470 TVL	
	EC-710-081P-CSA-C1D2	X	X	X	X	X				X	470 TVL	
	EC-710-081N-CSA-C1D2	X	X	X	X		X			X	470 TVL	

		Haz. Area Rating				Transmission Technology		Zoom				Resolution	
		Cl. I, II Div. 2	Zones 2, 22	Zones 1, 21	Cl. II, III Div. 1	Analog	IP Ethernet	3X	10X	30X	36X		
Zoom Camera	EC-910-AFZ-I03-P00	X	X	X			X		X			Full HD	Page 379
	EC-910-AFZ-I10-P00	X	X	X			X		X			Full HD	Page 381
	EC-940S-AFZ-HFI-W2F-55B	X	X	X			X			X		Full HD	Page 383
	EC-940S-AFZ-3NA-W2F-55	X	X	X		X					X	550 TVL	
	EC-940S-AFZ-3PA-W2F-55	X	X	X		X					X	550 TVL	

		Haz. Area Rating				Transmission Technology		Zoom		Resolution		
		Cl. I, II Div. 2	Zones 2, 22	Zones 1, 21	Cl. II, III Div. 1	Analog	IP Ethernet	30X	36X			
												PAL
Pan-Tilt- Zoom Camera	EC-940-PTZ-HFI-W2B	X	X	X			X		X		Full HD	Page 387
	EC-940-PTZ-A3N-W20	X	X	X		X				X	550 TVL	Page 389
	EC-940-PTZ-A3P-W20	X	X	X		X				X	550 TVL	

		Haz. Area Rating				Transmission Technology		Zoom		Resolution		
		Cl. I, II Div. 2	Zones 2, 22	Zones 1, 21	Cl. II, III Div. 1	Analog	IP Ethernet	640 x 512	336 X 256			
												PAL
Thermal Imag- ing Camera	EC-840S-TIC-19I-642-F55	X	X	X			X		X		< 50 mK to f/1.0	Page 391
	EC-840S-TIC-19I-332-F55	X	X	X			X			X	< 50 mK to f/1.0	
	EC-840S-TIC-19A-642-F55	X	X	X		X	X		X		< 50 mK to f/1.0	Page 393
	EC-840S-TIC-19A-332-F55	X	X	X		X	X			X	< 50 mK to f/1.0	

CAMERA SYSTEMS



Product	Series	Page	WebCode
Camera and Video Systems			
Camera Systems for all Areas		375	
Color Camera			
Analog Compact Camera Zone 1 / Class I, Div. 2	EC-710	377	EC710A
Analog PTZ Camera Zone 1 / Class I, Div. 2	EC-940-PTZ	389	EC940PTZAA
Analog Zoom Camera Zone 1 / Class I, Div. 2	EC-940S-AFZ	385	EC940SAFZAA
Full HD IP PTZ Camera Zone 1 / Class I, Div. 2	EC-940-PTZ	387	EC940PTZIA
Full HD IP Zoom Camera Zone 1 / Class I, Div. 2	EC-940S-AFZ	383	EC940SAFZIA
Full HD IP Zoom Camera Zone 1 / Class I, Div. 2	EC-910-AFZ-10x	381	EC910AFZA
Full HD IP Zoom Camera Zone 1 / Class I, Div. 2	EC-910-AFZ-3x	379	EC910AFZA
Thermal Imaging Camera			
Analog Thermal Imaging Camera Zone 1 / Class I, Div. 2	EC-840S-TIC	393	EC840STICAA
IP Thermal Imaging Camera Zone 1 / Class I, Div. 2	EC-840S-TIC	391	EC840STICIA
Video Software			
Qognify Video Software		395	CayugaA

For additional products and information please refer to r-stahl.com

Trust but verify

Increased safety

Camera systems play an increasingly important role for the safety onboard ships, drill rigs or in production plants - they are used to monitor work areas and processes to ensure general safety. Our "automated surveillance", combining camera systems with powerful software, guarantees that every part of the plant, even the hazardous areas, can be monitored. Areas not easily accessible can be monitored by the smallest explosion proof camera in the world; video surveillance is a job for the state-of-the-art Dome camera, and we offer a great variety of PTZ cameras for zoom and pan-tilt functions. The cameras from R. STAHL HMI Systems GmbH enable security staff to react quickly to any potential safety problems and thus prevent emergencies. If an emergency occurs, the cameras provide a comprehensive overview of the situation, thus enabling staff to make the necessary decisions preventing the situation from escalating.

Greater efficiency

In their everyday work system, operators profit from the advantages of a camera surveillance system. An improved overview of their workplace and its surroundings gives them control of the situation and enables them to work more efficiently and accurately. It is also possible to issue proactive warnings to anyone entering hazardous areas.

Damage limitation

Despite everyone's best efforts, it is not always possible to prevent accidents. Operating large machinery in tight spaces with many blind spots carries risks for life and machinery. A camera system from R. STAHL HMI Systems provides an extra pair of eyes - regardless of which machinery is used in which environment. Injuries or breakdowns can thus be prevented.

Improved ergonomics and user-friendliness

In most cases, cameras contribute towards improved ergonomics and user-friendliness. Fewer people need to be present in dangerous or hazardous areas. It is possible to distribute video images via a network, thus enabling several workers with different tasks to monitor the situation simultaneously and in real time. With the aid of visual feedback, decisions can be made from remote positions.

From component to complete system

Various camera types and appropriate video systems ensure optimal monitoring of installation conditions in hazardous and non-hazardous areas, and thus the highest degree of system safety. The smallest explosion proof camera in the world monitors very narrow rooms; the dome camera has been developed for video surveillance, while our PTZ and zoom camera has additional vertical pan and zoom functions. The explosion-proof thermal imaging cameras by R. STAHL HMI Systems ensure optimum monitoring day and night, for example on oil rigs. All cameras have been designed for hazardous areas and for installation in extreme ambient temperatures.

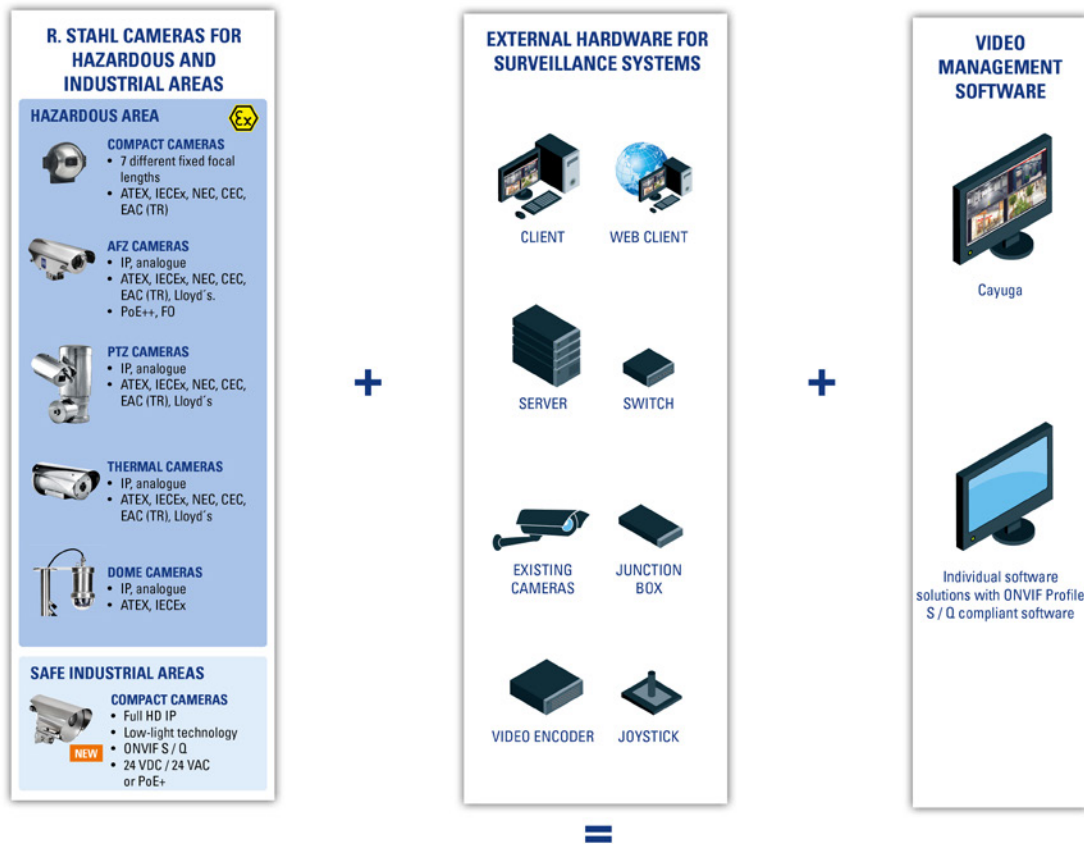

13b

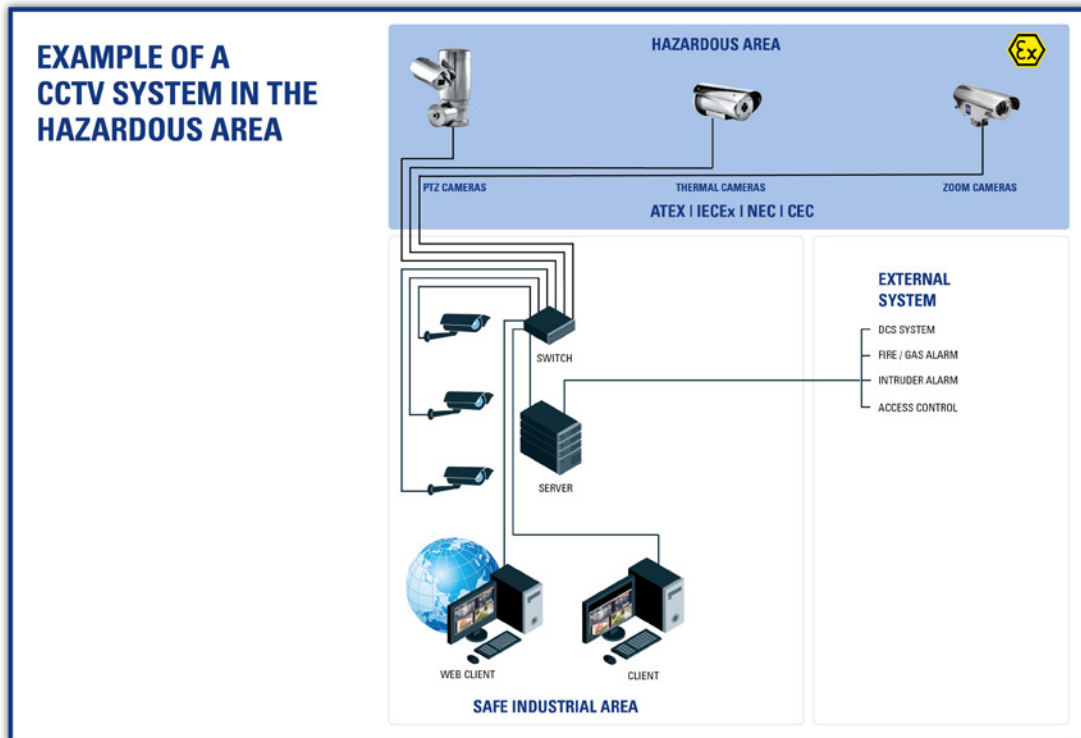



- Analog compact camera with fixed focus
- Certified acc. to ATEX, IECEx, NEC, CEC and EAC (TR) for world-wide operation in hazardous areas
- The world's smallest explosion proof camera: only 55 mm [2.17 "]
- Extremely robust: seawater-proof and resistant to shock and vibration, degree of protection IP69K, suitable for extreme temperature ranges

WebCode EC710A



The analog fixed camera EC-710 from R. STAHL is an uncomplicated surveillance camera for many types of application. Four versions with different viewing angles are available. The stainless-steel camera enclosure (316L) has degree of protection IP69K and can be cleaned easily and quickly with a pressure washer. The camera is also resistant to shock and vibration and suitable for extreme temperatures ranging from -40 °C to +75 °C [-40 °F to +167 °F], making it ideal for surveillance systems in rough ambient conditions. The low power consumption saves energy, and since the camera is also low-maintenance, it is ideal for independent surveillance. Certified for installation in hazardous zones 1 / 2 / 21 / 22; Cl. I, Div. 2; Cl. II, Div. 1 and 2; according to ATEX, IECEx, NEC, CEC and EAC (TR), the camera can be installed world-wide.

	NEC® 500 CEC Appendix J					
	Class I		Class II		Class III	
Division	1	2	1	2	1	2
Ex interface						
Installation in		•	•	•	•	•

	CEC Section 18 NEC® 505 NEC® 506					
	Class I					
Zone	0	1	2	20	21	22
Ex interface						
Installation in		•	•		•	•

	IECEx / ATEX					
	Zone	0	1	2	20	21
Ex interface						
Installation in		•	•		•	•

13 b

Selection Table				
Version	Fixed viewing angle			
Product Type	Viewing angle	TV system	Art. No.	Weight lb
EC-710-023P-CSA-C1D2	23° fixed	PAL	270932	1.65
EC-710-044P-CSA-C1D2	44° fixed	PAL	249860	1.53
EC-710-081P-CSA-C1D2	81° fixed	PAL	241104	1.65
EC-710-081N-CSA-C1D2	81° fixed	NTSC	265219	1.65

Technical Drawings – Subject to Alterations

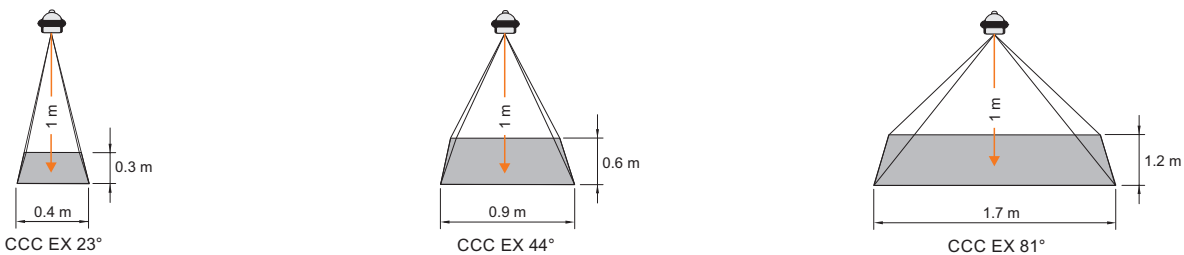

Accessories				
Figure	Description	Art. No.	Weight lb	
Ex e Terminal box				
	JCT-Terminal-Box Customized junction box Available upon request	-	1.76 lb	
Camera multi-cable standard				
	VB-CAM-MULTI-11-UNI 1 x coaxial cable 2 x power supplies 1 x data cable -40°C ... +85 °C [-40 °F ... +185 °F] Suitable for EC-710 and EC-750 (analog only) Price per meter	230585 ▲	0.11 lb	
Camera multi-cable armored				
	VB-CAM-MULTI-01-ARM 1 x coaxial cable 2 x power supplies 3 x data cables -40°C ... +85 °C [-40 °F ... +185 °F] Mud and oil-resistant Suitable for EC-710 and EC-750 (analog only) Price per meter	167535 ▲	0.26 lb	
Inspection glass mount				
	Inspection glass holder for EC-710-Series For EC-710-0xx cameras Stainless steel 316 Mounting position can be ordered individually	230675	4.19 lb	
Wall mount				
	Wall bracket for EC-710 Suitable for EC-710-0xx cameras V2A stainless steel Approx. 236 mm [9.29 inches] long Without camera	230669 ▲	0.44 lb	
Video Encoder				
	VS-AXIS-Q7424-R-MKII - H.264 and MJPEG video compression - H.264 and MJPEG streams - Alarm input and output - Power over Ethernet - SFP Slot - Voltage 8 ... 28 V DC - Temp. -40 ... +75 °C [-40 ... +167 °F]	245722	1.76 lb	

13 b

Full HD IP Zoom Camera Zone 1 / Class I, Div. 2

Series EC-910-AFZ-3x

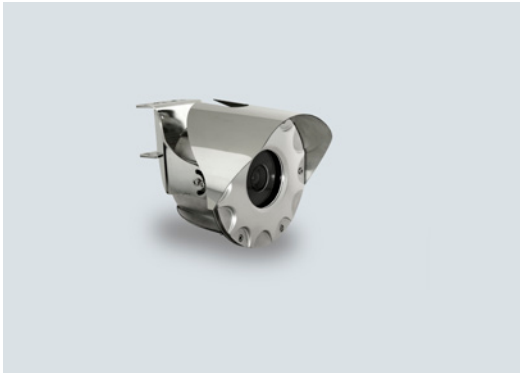

- All-round Full HD zoom camera with 3x zoom
- PoE+, 24 VDC or 24 VAC
- Including wall / ceiling mount bracket
- Zone 1, 2, 21, 22 and Cl. I, II, Div. 2
- Day / night, WDR, ONVIF S and Q

WebCode **EC910AFZA**



The EC-910-AFZ PoE+ camera combines state-of-the-art camera technology with Full HD resolution, WDR and zoom function for hazardous areas. The light-sensitive 3x zoom version features an extreme viewing angle of up to 90° (horizontal), making it ideal for monitoring rooms or inspection windows. To ensure guaranteed resistance to adverse weather, the EC-910-AFZ-I03 with 3x zoom has been tested and certified by Lloyd's Register for marine application. Lloyd's attests the camera's reliability with regard to temperature, corrosion and vibration resistance as well as EMC. This design makes the cameras universally applicable in the oil and gas industries and in the chemical, pharmaceutical, and related industries. The camera is certified acc. to ATEX, IECEx for Zone 1, 2, 21, 22. Additional certificates available are NEC Cl. I, II, Div. 2 and Cl. I Zone 1, CEC Zone 1 and EAC (TR). The stainless-steel sun protection and the wall / ceiling mount bracket are part of the standard delivery.



	NEC® 500 CEC Appendix J					
	Class I		Class II		Class III	
Division	1	2	1	2	1	2
Ex interface						
Installation in		•		•		

	CEC Section 18					
	NEC® 505 Class I			NEC® 506		
Zone	0	1	2	20	21	22
Ex interface						
Installation in		•			•	

	IECEx / ATEX					
	Zone	0	1	2	20	21
Ex interface						
Installation in		•	•		•	•

13b

Selection Table					
Focus	Automatic focus				
Zoom	3x optical				
Resolution	Full HD to 320x180p				
Viewing angle	90° (wide), 32° (tele.)				
Network protocol	ONVIF profile S and Q				
Product Type	Connection cable	Cable length	Certifications	Art. No.	Weight lb
EC-910-AFZ-I03-P00	without cable	0 m	ATEX, IECEx, EAC, NEC, CEC	264963	14.33

Accessories			
Figure	Description	Art. No.	Weight lb
Pole and Corner module EC-910			
	Pole and Corner module EC-910-AFZ Stainless steel 316L, electropolished Payload: 30 kg [66.14 lbs] Pole diameter: 60 mm ... 200 mm [2.36 x 7.87 inches] Dimension: 120 x 86 mm [4.72 x 3.39 inches]	264965	2.2 lb
Ex e Terminal box			
	JCT-Terminal-Box Customized junction box Available upon request	-	1.76 lb

Full HD IP Zoom Camera Zone 1 / Class I, Div. 2

Series EC-910-AFZ-10x

STAHL



- All-round Full HD zoom camera with 10x zoom
- PoE+, 24 VDC or 24 VAC
- Including wall / ceiling mount bracket
- Zone 1, 2, 21, 22 and Cl. I, II, Div. 2
- Day / night, WDR, ONVIF S and Q

WebCode **EC910AFZA**



The EC-910-AFZ PoE+ camera combines state-of-the-art camera technology with Full HD resolution, WDR, zoom and defog function for hazardous areas. The 10x zoom version provides sharp, crystal-clear images and is universally applicable in the oil and gas industries and in the chemical, pharmaceutical, and related industries.

To ensure guaranteed resistance to adverse weather, the EC-910-AFZ-I10 with 10x zoom has been tested and certified by Lloyd's Register for marine application. Lloyd's attests the camera's reliability with regard to temperature, corrosion and vibration resistance as well as EMC.

The camera is certified acc. to ATEX, IECEx for Zone 1, 2, 21, 22. Additional certificates available are NEC Cl. I, II, Div. 2 and Cl. I Zone 1, CEC Zone 1 and EAC (TR). The stainless-steel sun protection and the wall / ceiling mount bracket are part of the standard delivery.



	NEC® 500 CEC Appendix J					
	Class I		Class II		Class III	
Division	1	2	1	2	1	2
Ex interface						
Installation in		•		•		

	CEC Section 18					
	NEC® 505 Class I			NEC® 506		
Zone	0	1	2	20	21	22
Ex interface						
Installation in		•			•	

	IECEX / ATEX					
	Zone	0	1	2	20	21
Ex interface						
Installation in		•	•		•	•

13b

Selection Table						
Focus	Automatic focus					
Zoom	10x optical					
Resolution	Full HD to 320x180p					
Viewing angle	67° (wide), 7.6° (tele)					
Network protocol	ONVIF profile S and Q					
Product Type	Connection cable	Cable length	Certifications	Art. No.	Weight lb	
EC-910-AFZ-I10-P00	without cable	0 m	ATEX, IECEx, EAC, NEC, CEC	264964	14.33	

Accessories			
Figure	Description	Art. No.	Weight lb
Pole and Corner module EC-910			
	Pole and Corner module EC-910-AFZ Stainless steel 316L, electropolished Payload: 30 kg [66.14 lbs] Pole diameter: 60 mm ... 200 mm [2.36 x 7.87 inches] Dimension: 120 x 86 mm [4.72 x 3.39 inches]	264965	2.2 lb
Ex e Terminal box			
	JCT-Terminal-Box Customized junction box Available upon request	-	1.76 lb

Full HD IP Zoom Camera Zone 1 / Class I, Div. 2

Series EC-940S-AFZ



- Certified for hazardous Zone 1, 2, 21, 22 and Cl. I, II, Div. 2 acc. to ATEX, IECEx, NEC, CEC, EAC
- Low-Light-Technology for extremely detailed images, even in difficult lighting conditions
- Day / night - functionality
- IP Camera with Full HD for optimum image quality
- Delivery with conduit entry and 4 m [13.1 ft] pig tail cable set

WebCode **EC940SAFZIA**



R. STAHL's EC-940S-AFZ zoom cameras are all-rounders for surveillance in hazardous areas because in addition to an excellent panoramic view they also produce very good detailed images. This is the result of the IP camera's high resolution (Full HD with 1920 x 1080), the optical 30x zoom and the brilliant image quality - the WDR function (120 dB) optimizes the lighting of very bright or dark areas even in difficult lighting conditions. The built-in wiper and the defog function also ensure a clear view. The IP models are amongst the most modern cameras for hazardous areas and can be integrated into VMS systems worldwide via the ONVIF protocol (Profile S and Q). This surveillance camera is also available as an analog model that transmits images in real time.

	NEC® 500 CEC Appendix J					
	Class I		Class II		Class III	
Division	1	2	1	2	1	2
Ex interface						
Installation in		•		•		



	CEC Section 18					
	NEC® 505 Class I			NEC® 506		
Zone	0	1	2	20	21	22
Ex interface						
Installation in		•	•		•	•

	IECEX / ATEX					
	Zone	0	1	2	20	21
Ex interface						
Installation in		•	•		•	•

13b

Selection Table					
Focus	Auto, manual, trigger				
Zoom	30x optical				
Resolution	Full HD 1080p 1920x1080 pixel				
Network protocol	ONVIF profile S and Q				
Rated operational voltage AC	24 V				
Rated operational voltage DC	12 - 24 V				
Degree of protection (IP)	IP66 / IP68				
Product Type	Viewing angle	Cable structure	Certifications	Art. No.	Weight lb
EC-940S-AFZ-HFI-W2F-55B	61,6° (wide), 2,5° (tele)	Cable set not armored	ATEX, IECEx, NEC, CEC, EAC	271548	18.74

Accessories

Figure	Description	Art. No.	Weight lb
Camera multi-cable armored			
	VB-CAM-MULTI-Ethernet-ARM 1 x Ethernet cable 3 x power supplies 2.5 mm ² / AWG14 7 x data cable 0.34 mm ² / AWG22 -60 °C ... +80 °C [-76 °F ... +176 °F] 19.2 ±0.5 mm [0.76 ±0.02 inches] outer diameter IEC 60332-1 flame-resistant IEC 60754-2 halogen-free DIN 60811-404 oil-resistant NEK 606 mud-resistant Suitable for EC-910-AFZ, EC-940-PTZ-HDI and -HFI, EC-940-AFZ-HDI-O4H and -O5H, EC-940S-AFZ-Hxx, EC-840S-TIC-19I Price per meter	252571 ▲	1.04 lb
Ex e Terminal box			
	JCT-Terminal-Box Customized junction box Available upon request	-	1.76 lb
Wall bracket			
	Wall Bracket EC-x40S Suitable for EC-x40S series Material: 316L stainless steel, electropolished Capacity: max. 40 kg [88.18 lb] Length: 420 mm [16.54 inches]	251387	4.41 lb
Pole adapter module			
	Pole adapter module EC-x40S Suitable for EC-x40S For pole diameter 110 ... 150 mm [4.33 ... 5.9 inches] Material: 316L stainless steel, electropolished Capacity: max. 50 kg [110.23 lb] Weight: 3.3 kg [7.28 lb] Only together with wall bracket EC-x40S type 251387	251380	7.28 lb
Corner adapter module			
	Corner adapter module EC-x40S Suitable for EC-x40S series Material: 316L stainless steel, electropolished Capacity: max. 50 kg [110.23 lb] Only together with wall bracket EC-x40S type 251387	251381	4.41 lb
Parapet mounting bracket			
	Parapet mounting bracket EC-x40S Suitable for EC-x40S series Material: 316L stainless steel, electropolished Capacity: max. 70 kg [154.32 lb] Height: 124 mm [4.88 inches] Only together with ball joint adapter EC-x40S type 251388	251386	1.98 lb
Ball joint			
	Ball joint x40S 316L stainless steel, electropolished Capacity: max. 40 kg [88.18 lb] Diameter: 101.6 mm [4 inches]	251388	4.41 lb

13 b

Analog Zoom Camera Zone 1 / Class I, Div. 2

Series EC-940S-AFZ



- Certified for hazardous Zone 1, 2, 21, 22 and Cl. I, II, Div. 2 acc. to ATEX, IECEX, NEC, CEC, EAC
- Analog camera for real-time transmission
- Day / night - functionality
- Delivery with conduit entry and 4 m [13.1 ft] pig tail cable set

WebCode **EC940SAFZAA**



R. STAHL's EC-940S-AFZ zoom cameras are all-rounders for surveillance in hazardous areas because in addition to an excellent panoramic view they also produce very good detailed images. This is guaranteed by the high image definition (550 TVL) and the optical 36x zoom of the analog camera. The camera functions are controlled via RS-485 and PELCO D or Panasonic. The built-in wiper ensure a clear view. This analog surveillance camera series transmits images in real-time, providing users with a non-stop overview in time-critical applications.

	NEC® 500 CEC Appendix J					
	Class I		Class II		Class III	
Division	1	2	1	2	1	2
Ex interface						
Installation in		•		•		

	CEC Section 18					
	NEC® 505 Class I			NEC® 506		
Zone	0	1	2	20	21	22
Ex interface						
Installation in		•	•		•	•

	IECEX / ATEX					
	Zone	0	1	2	20	21
Ex interface						
Installation in		•	•		•	•

13 b

Selection Table					
Zoom	36x optical				
Focus	Automatic focus				
Interfaces	RS-485 half duplex				
Viewing angle	57.8° (wide), 1.7° (tele)				
Resolution	550 TVL				
Serial Communication Protocol	Panasonic 850, Pelco D, Macro				
Rated operational voltage AC	24 V				
Rated operational voltage DC	12 – 24 V				
Degree of protection (IP)	IP66, 68,				
Note on degree of protection	IP69 only enclosure				
Product Type	TV system	Cable structure	Certifications	Art. No.	Weight lb
EC-940S-AFZ-3NA-W2F-55	NTSC	Cable set not armored	ATEX, IECEX, NEC, CEC, EAC	257725	17.64
EC-940S-AFZ-3PA-W2F-55	PAL	Cable set not armored	ATEX, IECEX, NEC, CEC, EAC	257723	17.64

Accessories

Figure	Description	Art. No.	Weight lb
Camera multi-cable armored			
	VB-CAM-MULTI-Analog-ARM 1 x coaxial cable 3 x power supply 2.5 mm ² / AWG14 7 x data cable 0.34 mm ² / AWG22 -60 °C ... +80 °C [-76 °F ... +176 °F] 16.5 ±0.3 mm [0.65 ±0.01 inches] outer diameter IEC 60332-1 flame-resistant IEC 60754-2 halogen-free DIN 60811-404 oil-resistant NEK 606 mud-resistant Suitable for EC-940-PTZ-Axx, EC-940S-AFZ-3xA, EC-840S-TIC-19A	252572	1.21 lb
Ex e Terminal box			
	JCT-Terminal-Box Customized junction box Available upon request	-	1.76 lb
Wall bracket			
	Wall Bracket EC-x40S Suitable for EC-x40S series Material: 316L stainless steel, electropolished Capacity: max. 40 kg [88.18 lb] Length: 420 mm [16.54 inches]	251387	4.41 lb
Pole adapter module			
	Pole adapter module EC-x40S Suitable for EC-x40S For pole diameter 110 ... 150 mm [4.33 ... 5.9 inches] Material: 316L stainless steel, electropolished Capacity: max. 50 kg [110.23 lb] Weight: 3.3 kg [7.28 lb] Only together with wall bracket EC-x40S type 251387	251380	7.28 lb
Corner adapter module			
	Corner adapter module EC-x40S Suitable for EC-x40S series Material: 316L stainless steel, electropolished Capacity: max. 50 kg [110.23 lb] Only together with wall bracket EC-x40S type 251387	251381	4.41 lb
Parapet mounting bracket			
	Parapet mounting bracket EC-x40S Suitable for EC-x40S series Material: 316L stainless steel, electropolished Capacity: max. 70 kg [154.32 lb] Height: 124 mm [4.88 inches] Only together with ball joint adapter EC-x40S type 251388	251386	1.98 lb
Ball joint			
	Ball joint x40S 316L stainless steel, electropolished Capacity: max. 40 kg [88.18 lb] Diameter: 101.6 mm [4 inches]	251388	4.41 lb

13 b

Full HD IP PTZ Camera Zone 1 / Class I, Div. 2

Series EC-940-PTZ



- Certified for hazardous Zone 1, 2, 21, 22 and Cl. I, II, Div. 2 acc. to ATEX, IECEx, NEC, CEC
- Enclosure made from electropolished stainless steel (316L), ideal for clean rooms as well as the oil and gas industries
- Extremely precise pan-tilt surveillance camera with full HD resolution (1920 x 1080)
- In less than 2 seconds each target reachable - up to 100°/s
- Extreme precise positioning 0.02°

WebCode **EC940PTZIA**



Use R. STAHL's EC-940-PTZ camera to keep all monitored areas in perfect view and to pan from one object to the next in no time at all. After all, it is the fastest pan-tilt camera for hazardous areas. Its Full HD resolution provides detailed images, and a wiper ensures a free view at all times, making this surveillance camera ideal for all-round and detailed surveillance. It can be incorporated into state-of-the-art video systems worldwide, using the ONVIF protocol (Profile S). In addition, it is seawater resistant and its degree of protection IP66 means it can be operated in temperatures ranging from -40 °C to +65 °C [-40 °F to +149 °F], for example on drilling rigs, refineries or tankfarms, as well as for monitoring processes in chemical and pharmaceutical production and in clean rooms.

	NEC® 500 CEC Appendix J					
	Class I		Class II		Class III	
Division	1	2	1	2	1	2
Ex interface						
Installation in		•		•		

	CEC Section 18					
	NEC® 505 Class I			NEC® 506		
Zone	0	1	2	20	21	22
Ex interface						
Installation in		•	•		•	•

	IECEx / ATEX					
	Zone	0	1	2	20	21
Ex interface						
Installation in		•	•		•	•

13b

Selection Table				
Resolution	Full HD 1080p 1920x1080 pixel			
Viewing angle	61,6° (wide), 2,5° (tele)			
Horizontal speed (vari)	0,1°/s ... 100°/s			
Vertical speed (vari)	0,1°/s ... 100°/s			
Accuracy preset position	0.02 °			
Focus	Auto, manual, trigger			
Network protocol	ONVIF profile S and Q			
Degree of protection (IP)	IP66			
Product Type	Rated operational voltage AC	Certifications	Art. No.	Weight lb
EC-940-PTZ-HFI-W2B	24 V	ATEX, IECEx, NEC, CEC, EAC	271545	59.52

Accessories				
Figure	Description	Art. No.	Weight lb	
Wall bracket				
	Wall bracket EC-940-PTZ 316L stainless steel, electropolished Capacity: max. 40 kg [88.18 lb] Length: 400 mm [15.75 inches]	251364	2.2 lb	
Pole mounting				
	Pole adapter module EC-940-PTZ Material: 316L stainless steel, electropolished For pole diameter 110 ... 150 mm [4.33 ... 5.9 inches] Capacity: max. 50 kg [110.23 lb] Only together with wall bracket EC-940-PTZ type 251364	251362	11.02 lb	
Corner adapter module				
	Corner adapter module EC-940-PTZ Material: 316L stainless steel, electropolished Capacity: max. 50 kg [110.23 lb] WxH: 335 x 186 mm [13.19 x 7.32 inches] Only together with wall bracket for EC-940-PTZ type 251364	251363	4.41 lb	
Parapet mounting bracket				
	Parapet mounting bracket EC-940-PTZ Material: 316L stainless steel, electropolished Capacity: max. 40 kg [88.18 lb] Diameter: 238 mm [9.37 inches]	251365	2.2 lb	
Camera multi-cable armored				
	VB-CAM-MULTI-Ethernet-ARM 1 x Ethernet cable 3 x power supplies 2.5 mm ² / AWG14 7 x data cable 0.34 mm ² / AWG22 -60 °C ... +80 °C [-76 °F ... +176 °F] 19.2 ±0.5 mm [0.76 ±0.02 inches] outer diameter IEC 60332-1 flame-resistant IEC 60754-2 halogen-free DIN 60811-404 oil-resistant NEK 606 mud-resistant Suitable for EC-910-AFZ, EC-940-PTZ-HDI and -HFI, EC-940-AFZ-HDI-O4H and -O5H, EC-940S-AFZ-Hxx, EC-840S-TIC-19I Price per meter	252571 ▲	1.04 lb	
Cable glands				
	CMP-25sPX2K-REX-MSNi-NPT 3/4"-SET Cable gland with RapidEx compound explosion-protected for EC-940-PTZ	275572	0.94 lb	

13 b

Analog PTZ Camera Zone 1 / Class I, Div. 2

Series EC-940-PTZ



- Certified for hazardous Zone 1, 2, 21, 22 and Cl. I, II, Div. 2 acc. to ATEX, IECEx, NEC, CEC, EAC
- Enclosure made from electropolished stainless steel (316L), ideal for clean rooms as well as the oil and gas industries
- Precise, analog pan-tilt surveillance camera
- Focus on any one point in under 2 seconds Up to 100°/s. Extremely exact positioning 0.02°.

WebCode **EC940PTZAA**



Use R. STAHL's EC-940-PTZ camera to keep all monitored areas in perfect view and to pan from one object to the next in no time at all - after all, it is one of the fastest pan-tilt camera for hazardous areas. Its high resolution (550 TVL) and 36x zoom provides detailed images, and a wiper ensures free view at all times, making this surveillance camera ideal for all-round and detailed surveillance. The camera functions are controlled via RS-485 and PELCO D, Panasonic, etc. This analog surveillance camera series transmits images in real-time, providing users with a non-stop overview in time-critical applications. In addition, it is seawater resistant and its degree of protection IP66 means it can be operated in temperatures ranging from -40 °C to +65 °C [-40 °F to +149 °F], for example on drilling rigs, refineries or tankfarms, as well as for monitoring processes in chemical and pharmaceutical production and in clean rooms.

	NEC® 500 CEC Appendix J					
	Class I		Class II		Class III	
Division	1	2	1	2	1	2
Ex interface						
Installation in		•		•		

	CEC Section 18 NEC® 505 NEC® 506					
	Class I			Class II		
Zone	0	1	2	20	21	22
Ex interface						
Installation in		•	•		•	•

	IECEx / ATEX					
	Zone 1		Zone 2		Zone 21/22	
Zone	0	1	2	20	21	22
Ex interface						
Installation in		•	•		•	•

13b

Selection Table					
Resolution	550 TVL				
Viewing angle	57.8° (wide), 1.7° (tele)				
Horizontal speed (vari)	0,1°/s ... 100°/s				
Vertical speed (vari)	0,1°/s ... 100°/s				
Accuracy preset position	0.02°				
Focus	Automatic focus				
Interfaces	RS-485 half duplex				
Serial Communication Protocol	American Dynamics, Ernitec, Panasonic, Pelco D				
Degree of protection (IP)	IP66				
Product Type	TV system	Rated operational voltage AC	Certifications	Art. No.	Weight lb
EC-940-PTZ-A3N-W20	NTSC	24 V	ATEX, IECEx, NEC, CEC, EAC	257726	59.52
EC-940-PTZ-A3P-W20	PAL	24 V	ATEX, IECEx, NEC, CEC, EAC	257728	59.52

Accessories			
Figure	Description	Art. No.	Weight lb
Wall bracket			
	Wall bracket EC-940-PTZ 316L stainless steel, electropolished Capacity: max. 40 kg [88.18 lb] Length: 400 mm [15.75 inches]	251364	2.2 lb
Pole mounting			
	Pole adapter module EC-940-PTZ Material: 316L stainless steel, electropolished For pole diameter 110 ... 150 mm [4.33 ... 5.9 inches] Capacity: max. 50 kg [110.23 lb] Only together with wall bracket EC-940-PTZ type 251364	251362	11.02 lb
Corner adapter module			
	Corner adapter module EC-940-PTZ Material: 316L stainless steel, electropolished Capacity: max. 50 kg [110.23 lb] WxH: 335 x 186 mm [13.19 x 7.32 inches] Only together with wall bracket for EC-940-PTZ type 251364	251363	4.41 lb
Parapet mounting bracket			
	Parapet mounting bracket EC-940-PTZ Material: 316L stainless steel, electropolished Capacity: max. 40 kg [88.18 lb] Diameter: 238 mm [9.37 inches]	251365	2.2 lb
Camera multi-cable armored			
	VB-CAM-MULTI-Analog-ARM 1 x coaxial cable 3 x power supply 2.5 mm ² / AWG14 7 x data cable 0.34 mm ² / AWG22 -60 °C ... +80 °C [-76 °F ... +176 °F] 16.5 ±0.3 mm [0.65 ±0.01 inches] outer diameter IEC 60332-1 flame-resistant IEC 60754-2 halogen-free DIN 60811-404 oil-resistant NEK 606 mud-resistant Suitable for EC-940-PTZ-Axx, EC-940S-AFZ-3xA, EC-840S-TIC-19A	252572	1.21 lb
Cable glands			
	CMP-25sPX2K-REX-MSNi-NPT 3/4"-SET Cable gland with RapidEx compound explosion-protected for EC-940-PTZ	275572	0.94 lb

IP Thermal Imaging Camera Zone 1 / Class I, Div. 2

Series EC-840S-TIC



- High-resolution IP thermal imaging camera
- Certified for hazardous Zone 1, 2, 21, 22 and Cl. I, II, Div. 2 acc. to ATEX, IECEx, NEC, CEC, EAC
- Enclosure made from electropolished stainless steel (316L), ideal for clean rooms as well as the oil and gas industries
- Delivery with conduit entry and 4 m [13.1 ft] pig tail cable set

WebCode **EC840STICIA**



R. STAHL's EC-840S-TIC-19I IP thermal imaging camera is one of the most modern explosion-protected cameras currently on the market. Its integrated thermography function ensures clear and safe recognition of changes in temperature by color coding specific temperature zones - according to your settings, precisely tailored to the process under surveillance. This range of versions includes a suitable model for every surveillance system: The IP cameras support the ONVIF protocol (profile S) for network integration worldwide. All models are available with either high or medium resolution. These surveillance cameras are certified acc. to ATEX, IECEx, NEC, CEC and EAC for hazardous Zone 1, 2, 21, 22 and Cl. I, II, Div. 2 and are therefore suitable for installation in many regions.

	NEC® 500 CEC Appendix J					
	Class I		Class II		Class III	
Division	1	2	1	2	1	2
Ex interface						
Installation in		•		•		

	CEC Section 18					
	NEC® 505 Class I			NEC® 506		
Zone	0	1	2	20	21	22
Ex interface						
Installation in		•	•		•	•

	IECEx / ATEX					
	Zone	0	1	2	20	21
Ex interface						
Installation in		•	•		•	•

13 b

Selection Table						
Resolution	< 50 mK to f/1.0					
Network protocol	ONVIF profile S					
Rated operational voltage AC	24 V					
Rated operational voltage DC	12 – 24 V					
Degree of protection (IP)	IP66, 68,					
Note on degree of protection	IP69 only enclosure					
Product Type	Viewing angle	Person (detect/recog/ident)	Total pixels	Certifications	Art. No.	Weight lb
EC-840S-TIC-19I-642-F55	32° fixed	570 m / 144 m / 72 m	640 (H) x 512 (V)	ATEX, IECEx, NEC, CEC, EAC	252762	17.64
EC-840S-TIC-19I-332-F55	17° fixed	640 m / 180 m / 80 m	336 (H) x 256 (V)	ATEX, IECEx, NEC, CEC, EAC	252761	17.64

Accessories			
Figure	Description	Art. No.	Weight lb
Camera multi-cable armored			
	VB-CAM-MULTI-Ethernet-ARM 1 x Ethernet cable 3 x power supplies 2.5 mm ² / AWG14 7 x data cable 0.34 mm ² / AWG22 -60 °C ... +80 °C [-76 °F ... +176 °F] 19.2 ±0.5 mm [0.76 ±0.02 inches] outer diameter IEC 60332-1 flame-resistant IEC 60754-2 halogen-free DIN 60811-404 oil-resistant NEK 606 mud-resistant Suitable for EC-910-AFZ, EC-940-PTZ-HDI and -HFI, EC-940-AFZ-HDI-O4H and -O5H, EC-940S-AFZ-Hxx, EC-840S-TIC-19I Price per meter	252571 ▲	1.04 lb
Ex e Terminal box			
	JCT-Terminal-Box Customized junction box Available upon request	-	1.76 lb
Wall bracket			
	Wall Bracket EC-x40S Suitable for EC-x40S series Material: 316L stainless steel, electropolished Capacity: max. 40 kg [88.18 lb] Length: 420 mm [16.54 inches]	251387	4.41 lb
Pole adapter module			
	Pole adapter module EC-x40S Suitable for EC-x40S For pole diameter 110 ... 150 mm [4.33 ... 5.9 inches] Material: 316L stainless steel, electropolished Capacity: max. 50 kg [110.23 lb] Weight: 3.3 kg [7.28 lb] Only together with wall bracket EC-x40S type 251387	251380	7.28 lb
Corner adapter module			
	Corner adapter module EC-x40S Suitable for EC-x40S series Material: 316L stainless steel, electropolished Capacity: max. 50 kg [110.23 lb] Only together with wall bracket EC-x40S type 251387	251381	4.41 lb
Parapet mounting bracket			
	Parapet mounting bracket EC-x40S Suitable for EC-x40S series Material: 316L stainless steel, electropolished Capacity: max. 70 kg [154.32 lb] Height: 124 mm [4.88 inches] Only together with ball joint adapter EC-x40S type 251388	251386	1.98 lb
Ball joint			
	Ball joint x40S 316L stainless steel, electropolished Capacity: max. 40 kg [88.18 lb] Diameter: 101.6 mm [4 inches]	251388	4.41 lb

13 b

Analog Thermal Imaging Camera Zone 1 / Class I, Div. 2

Series EC-840S-TIC

STAHL



- High-resolution analog thermal imaging camera
- Certified for hazardous Zone 1, 2, 21, 22 and Cl. I, II, Div. 2 acc. to ATEX, IECEx, NEC, CEC, EAC
- Enclosure made from electropolished stainless steel (316L), ideal for clean rooms as well as the oil and gas industries
- Delivery with conduit entry and 4 m [13.1 ft] pig tail cable set

WebCode **EC840STICAA**



R. STAHL's EC-840S-TIC-19A analog thermal imaging camera is one of the most modern explosion-protected cameras currently on the market. Its integrated thermography function ensures clear and safe recognition of changes in temperature by color coding specific temperature zones - according to your settings, precisely tailored to the process under surveillance. The analog camera functions are controlled via RS-485 with Pelco D or Panasonic protocol. All models are available with high or medium resolution. These surveillance cameras are certified acc. to ATEX, IECEx, NEC, CEC and EAC for hazardous Zone 1, 2, 21, 22 and Cl. I, II, Div. 2 and are therefore suitable for installation in many regions.

	NEC® 500 CEC Appendix J					
	Class I		Class II		Class III	
Division	1	2	1	2	1	2
Ex interface						
Installation in		•		•		

	CEC Section 18					
	NEC® 505 Class I			NEC® 506		
Zone	0	1	2	20	21	22
Ex interface						
Installation in		•	•		•	•

	IECEx / ATEX					
	Zone	0	1	2	20	21
Ex interface						
Installation in		•	•		•	•

13 b

Selection Table						
Interfaces	RS-485 half duplex					
Resolution	< 50 mK to f/1.0					
Serial Communication Protocol	Panasonic, Pelco D, Macro					
Frame rate (fps)	8.3 PAL, 7.5 NTSC					
Rated operational voltage AC	24 V					
Rated operational voltage DC	12 – 24 V					
Degree of protection (IP)	IP66, 68,					
Note on degree of protection	IP69 only enclosure					
Product Type	Viewing angle	Total pixels	Person (detect/recog/ident)	Certifications	Art. No.	Weight lb
EC-840S-TIC-19A-642-F55	32° fixed	640 (H) x 512 (V)	570 m / 144 m / 72 m	ATEX, IECEx, NEC, CEC, EAC	252710	17.64
EC-840S-TIC-19A-332-F55	17° fixed	336 (H) x 256 (V)	640 m / 180 m / 80 m	ATEX, IECEx, NEC, CEC, EAC	252709	17.64

Accessories

Figure	Description	Art. No.	Weight lb
Camera multi-cable armored			
	VB-CAM-MULTI-Analog-ARM 1 x coaxial cable 3 x power supply 2.5 mm ² / AWG14 7 x data cable 0.34 mm ² / AWG22 -60 °C ... +80 °C [-76 °F ... +176 °F] 16.5 ±0.3 mm [0.65 ±0.01 inches] outer diameter IEC 60332-1 flame-resistant IEC 60754-2 halogen-free DIN 60811-404 oil-resistant NEK 606 mud-resistant Suitable for EC-940-PTZ-Axx, EC-940S-AFZ-3xA, EC-840S-TIC-19A	252572	1.21 lb
Ex e Terminal box			
	JCT-Terminal-Box Customized junction box Available upon request	-	1.76 lb
Wall bracket			
	Wall Bracket EC-x40S Suitable for EC-x40S series Material: 316L stainless steel, electropolished Capacity: max. 40 kg [88.18 lb] Length: 420 mm [16.54 inches]	251387	4.41 lb
Pole adapter module			
	Pole adapter module EC-x40S Suitable for EC-x40S For pole diameter 110 ... 150 mm [4.33 ... 5.9 inches] Material: 316L stainless steel, electropolished Capacity: max. 50 kg [110.23 lb] Weight: 3.3 kg [7.28 lb] Only together with wall bracket EC-x40S type 251387	251380	7.28 lb
Corner adapter module			
	Corner adapter module EC-x40S Suitable for EC-x40S series Material: 316L stainless steel, electropolished Capacity: max. 50 kg [110.23 lb] Only together with wall bracket EC-x40S type 251387	251381	4.41 lb
Parapet mounting bracket			
	Parapet mounting bracket EC-x40S Suitable for EC-x40S series Material: 316L stainless steel, electropolished Capacity: max. 70 kg [154.32 lb] Height: 124 mm [4.88 inches] Only together with ball joint adapter EC-x40S type 251388	251386	1.98 lb
Ball joint			
	Ball joint x40S 316L stainless steel, electropolished Capacity: max. 40 kg [88.18 lb] Diameter: 101.6 mm [4 inches]	251388	4.41 lb

13 b



- Up to 50 cameras (S50X version)
- 1 server (S50X version)
- Live / archive mode
- Mobile Client
- Site plans
- Additional packets available: S100 and Infinity

WebCode CayugaA

Qognify Cayuga is available as three basic packages, S50X, S100 and Infinity - meeting different requirements of different project sizes. All products are based on the same technical platform. Upgrades are therefore easily achieved by importing a new license key. The camera channels are licensed separately.

	NEC® 500 CEC Appendix J					
	Class I		Class II		Class III	
Division	1	2	1	2	1	2
Ex interface						
Installation in						

	CEC Section 18 NEC® 505 NEC® 506					
	Class I					
Zone	0	1	2	20	21	22
Ex interface						
Installation in						

	IECEX / ATEX					
	Class I					
Zone	0	1	2	20	21	22
Ex interface						
Installation in						

Selection Table			
Version	Video software		
Description	Art. No.	Weight lb	
Qognify Cayuga S50X video management software	239083	0.22	

13 b

Accessories			
Figure	Description	Art. No.	Weight lb
Video license for Qognify			
	Qognify Cayuga S50 X Camera Channel Qognify Cayuga S50X camera license, required for each camera	239084	0.22

System requirements for software installation see: <https://www.seetec-video.com/products/cayuga/specifications/>

Type	Type Description	Page
81xx		
8146/1	Terminal Boxes Ex e	362
8146/2	Terminal Boxes Ex i	364
8150/1	Terminal Boxes Ex e	367
8150/2	Terminal Boxes Ex i	369
82xx		
8265	Wi-Fi Access Point	329
90xx		
9001	Single-Channel Zener Barriers	232
9002	Dual-Channel Zener Barriers	248
91xx		
9146	Frequency Transmitter	152
9147	Vibration Transducer Supply Unit	154
9160	Transmitter Supply Unit	156
9162	Transmitter Supply Unit	163
9164	mA-Isolating Repeater	165
9165	Isolating Repeater	167
9167	Isolating Repeater Loop Powered	171
9170	Switching Repeater	174
9172	I.S. Relay Module	181
9175	Binary Output	184
9176	Digital Output Loop Powered	189
9180	Resistance Isolator	194
9182	Temperature Transmitter	197
9185/11	Fieldbus Isolating Repeater	336
9185/12	Fieldbus Isolating Repeater	338
9186/.5	Fiber Optics Fieldbus Isolating Repeater	340
9192	HART Multiplexer	202
9193	Supply Module	205
9194	pac-Bus	207
9195	pac-Carrier	211
9196	HART Termination Board	214
92xx		
9260	Transmitter Supply Unit	160
9265	Isolating Repeater	169
9270	Switching Repeater	178
9275	Binary Output	187
9276	Digital Output Loop Powered	192
9282	Temperature Transmitter	200
9294	pac-Bus	209
94xx		
9410	Ex n Field Device Coupler	285
9411/21	Ex i Field Device Coupler 4 Spurs	277
9411/21	Ex i Field Device Coupler 8 Spurs	279
9411/24	Ex i Field Device Coupler 4 Spurs	281
9411/24	Ex i Field Device Coupler 8 Spurs	283
9412	Fieldbus Power Supply	269
9415	Diagnosis Communication Module	272
9418	Fieldbus Terminator	287
9419	bus-Carrier	275
9440/15	CPU & Power-Module	63
9440/22	CPU & Power Module	60

Type	Type Description	Page
94xx		
9441/12	Ethernet CPU Module	73
9442/35	CPU Module	66
9444/12	Ethernet Power Module	77
9445/35	Power Module	70
9468/32	Analog Universal Module HART	80
9468/33	Analog Universal Module HART	83
9469/35	Analog Universal Module HART	86
9470/32	Digital Input Output Module	89
9470/33	Digital Input Output Module	92
9471/35	Digital Input Output Module NAMUR	95
9472/35	Digital Input Output Module 24 V	98
9475/32-08	Digital Output Module 8-Channel Version	108
9475/32-04	Digital Output Module 4-Channel Version	101
9475/32-04-72	Digital Output Module 4-Channel Version	105
9475/33-08	Digital Output Module 8-Channel Version	112
9477/12	Digital Output Module Relay	115
9477/15	Digital Output Module Relay	117
9478	Digital Output Module Valve	120
9482/32	Temperature Input Module	122
9482/33	Temperature Input Module	125
9494	BusRail	129
97xx		
9721	Media Converter	331
9721	Unmanaged Switch	333
9730	HFisolator	327
ECxx		
EC-940-PTZ	Analog PTZ Camera Zone 1 / Class I, Div. 2	389
EC-940-PTZ	Full HD IP PTZ Camera Zone 1 / Class I, Div. 2	387
EC-940S-AFZ	Analog Zoom Camera Zone 1 / Class I, Div. 2	385
EC-940S-AFZ	Full HD IP Zoom Camera Zone 1 / Class I, Div. 2	383
EC-910-AFZ-10x	Full HD IP Zoom Camera Zone 1 / Class I, Div. 2	381
EC-910-AFZ-3x	Full HD IP Zoom Camera Zone 1 / Class I, Div. 2	379
EC-840S-TIC	Analog Thermal Imaging Camera Zone 1 / Class I, Div. 2	393
EC-840S-TIC	IP Thermal Imaging Camera Zone 1 / Class I, Div. 2	391
EC-710	Analog Compact Camera Zone 1 / Class I, Div. 2	377
FLxx		
FL60	Visual Signaling Devices	358
YAxx		
YA11	Audible Signaling Devices	355
YA60	Audible Signaling Devices	352
YA90	Audible Signaling Devices	349
YLxx		
YL60	Combined Audible and Visual Signaling Devices	345