



Distance measurement
and user data transmission



High-Precision Distance Measurement and Reliable Collision Avoidance

LPR[®]-1D24

The LPR[®]-1D24 is a highly precise radio sensor for distance measurement. A single pair of sensors performs long range measurements with high accuracy. At the same time, additional measurement data such as the hook height or load status of a crane can be transferred via the wireless LPR[®] channel¹⁾. The relative approach speed of the LPR[®] sensors is also available.

Distance and speed readings can be used to avoid collisions by issuing alarms at predefined thresholds, for example via on-board relays. All data is available at standard interfaces on each unit in real-time.

Since the multi-channel radio antenna is integrated in the robust housing, the devices are easy to install and operate. A rough alignment between the facing units is sufficient for precise measurements, even over very long distances. The units can be easily configured and commissioned via a user-friendly HTML-based interface. No special software is needed.



The Symeo LPR[®] radio is highly reliable, even under adverse environmental conditions. It never interferes with WiFi equipment operating in its proximity. LPR[®]-1D24 sensors are maintenance-free.

Paired sensors can be interconnected with other pairs via data interfaces, thus making it possible to provide a crane's XY position simultaneously and make all measurement data available for further processing on all units.

- **Easy commissioning**
- **Exact position detection**
- **Contactless measurement by means of radio waves**
- **Unaffected by contamination, weather and vibration**
- **Usable indoors and outdoors**
- **Ideal for semi-automatic and fully automatic machine movement control**
- **Maintenance-free, even in harsh environments**

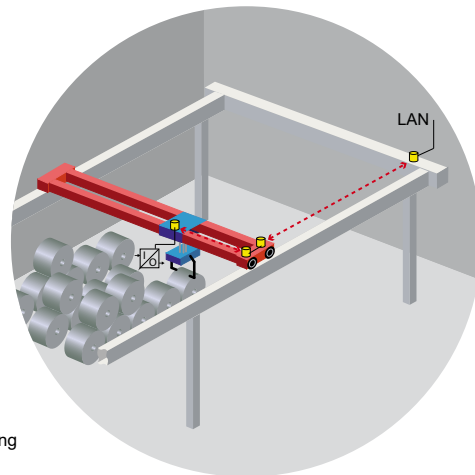
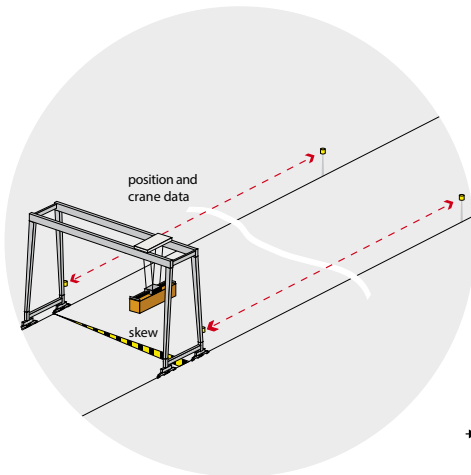
Typical LPR®-1D24 applications



-  LPR®-1D24
-  I/O Signal Handling

Dimensions: (in mm)

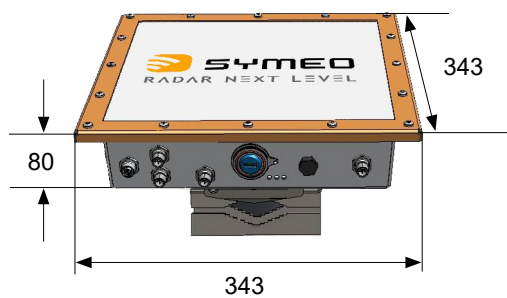

Connectors:

- Power supply
- Ethernet
- Relay contacts¹⁾
- Profibus¹⁾
- Waterproof connector for external USB stick for logging and monitoring

LED indicators:

- Power/measurement active
- Network
- Application

Technical Data: LPR®-1D24

Model number	BSV101757
Frequency range	24 to 24.25 GHz ³⁾
Transmission power (EIRP)	Up to 20 dBm
Measurement range	Up to 1,000 m ^{1), 2)}
Accuracy	Up to ±2.5 cm ^{1), 2)}
Measurement rate	30 Hz
Supply voltage	10-36 V DC
Power consumption	18 W
Ambient temperature	-40 °C to +75 °C (-40 °F to +167 °F)
Protection class	IP65
Weight	3.8 kg
Interfaces	Ethernet (TCP/IP, UDP, Profinet ¹⁾), Profibus ¹⁾
Response time	< 20 ms
Status indicators	LED
Data transmission	Position data, user data ¹⁾ , relay data ¹⁾
User data transfer rate	100 bytes/cycle, up to 3 Kbps
MTBF ¹⁾	19.6 a (sp), 21.0 a (sr) or 21.7 a (s)
External connectors	Ethernet (M12 D-coded), power supply (M12 T-coded), USB
Antenna	Integrated, multi-channel antenna diversity
Compliance	CE, FCC, IC (others on request)

1) Optional, depending on product version purchased. For more information, please see the product documentation available in the "Partner Login" area at www.symeo.com or from the Symeo Support.

2) Depending on application conditions.

3) Bandwidth limited to 100 MHz in India, France, and GB; reduced system performance.