

MEMBRANE PRESSOSTAT

Swiss based Trafag is a leading international supplier of high quality sensors and monitoring instruments for measurement of pressure and temperature.



Applications

- Machine tools
- HVAC

Features

- Rugged aluminium housing
- Protection IP65
- Any mounting position possible

Technical Data

Measuring principle	Membrane	Repeatability	± 1.0 % FS typ.
Measuring range	0.02 ... 0.25 to 0.05 ... 1 bar	Media temperature	-40°C ... +150°C
Output signal	1 Floating change-over contact (SPDT)	Ambient temperature	-25°C ... +70°C
Switching differential	Not adjustable	Approval / conformity	EN60730-1/ EN60730-2-6: Typ 2.B.H

11/2024

Data sheet H72262q

Subject to change

Ordering information/type code

		XXX	XX	XX	XXX	XX	XX
Custom build code	With display and adjusting screw	900					
	Without display, with adjusting screw	904					
	With display and adjusting knob	912					
Microswitch	Small switching differential, standard vibration resistance ¹⁾		10				
	Average switching differential, standard vibration resistance ¹⁾		11				
	Average switching differential, increased vibration resistance ¹⁾		23				
	Large switching differential, high vibration resistance ¹⁾		26				
	With gold plated contacts, standard vibration resistance ¹⁾		21				
Range	Range [bar]	Over pressure [bar]	Burst pressure [bar]				
	0.02 ... 0.25	2	4		46		
	0.03 ... 0.4	2	4		47		
	0.04 ... 0.6	4	7.5		48		
	0.05 ... 1.0	4	7.5		49		
Sensor	Sensor material	Sensor housing material	Thread	Range			
	EFFBE	Anodized aluminium	G1/4" female	46, 47		740	
	EFFBE	Anodized aluminium	G1/4" female	48, 49		742	
Fixing	Direct on sensor or housing						00
Accessories	Lead seal (manipulation protection)						16
	Screwed cable gland M24x1.5 (DIN89280)						27
	Screwed cable gland M18x1.5 (DIN89280)						40

¹⁾ Switching differential not adjustable

Specifications		
Accuracy	Repeatability	± 1.0 % FS typ.
	Scale accuracy typ.	± 2.0 % FS typ.
	Switching differential	See table
	Adjustment range switchpoint ²⁾	10% ... 90% FS
Environmental conditions	Ambient temperature	-25°C ... +70°C
	Media temperature	-40°C ... +150°C
	Storage temperature	-25°C ... +85°C
	Protection	IP65
	Humidity	Max. 95 % relative
	Vibration	Switch 23/26: 5...25 Hz: ±1.6 mm 25...100 Hz: 4g
	Shock	50g/ 11ms
Mechanical Data	Sensor ¹⁾	Anodized aluminium, EFFBE
	Housing	AlSi10Mg/ Epoxy coated
	Sealing	NBR
	Screwed cable gland	Brass nickel plated
	Mounting torque	Max. 25 Nm
	Installation	any position
	Weight	~ 850 g
Microswitch	Rating	See table
	Resistance of insulation	> 2 MΩ
	Dielectric strength	U ≤ 250V: 1.45 kV / U ≤ 500V: 2 kV terminal ground
	Life time (mechanical)	Microswitch 10/11: 20 Mio. cycles Microswitch 21: 0.5 Mio. cycles Microswitch 23/26: 0.3 Mio. cycles
Electrical connection	Electrical connections	Terminal screw
	Cable gland	M20x1.5 Cable-Ø 6...13 mm
	Terminal screw	3 x 0.5...4 mm ²

¹⁾ Membrane: EFFBE

Resistance: Acetylene, Hydrogen, Natural gas, Propane, Sea water, Glycols, Sulphur Dioxide, Water, Butane, Methane, Diesel

²⁾ Other adjustment ranges upon request

Additional information

Documents

Data sheet

www.trafag.com/H72262

Dimensions

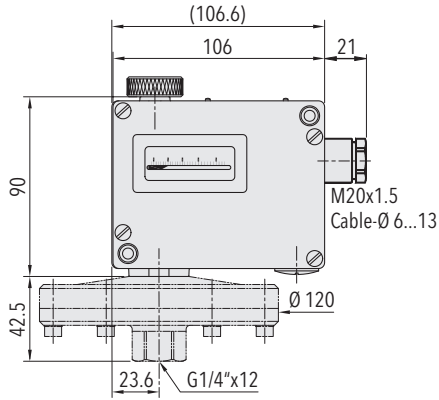

912.XX46/47.740

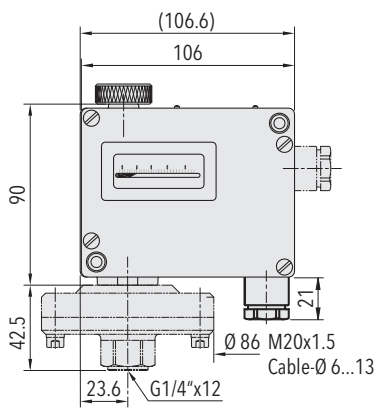

912.XX48/49.742

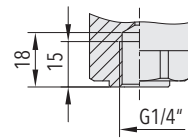

G1/4" femelle

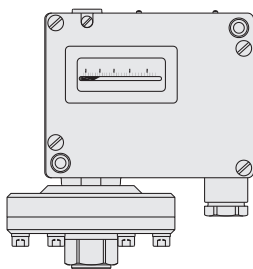

900

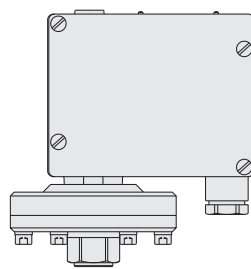

904

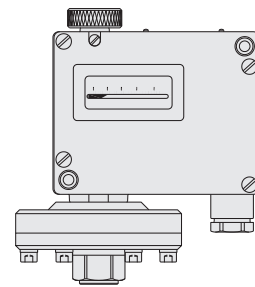

912

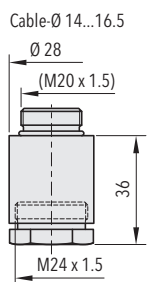

9XX.XX.XX.XX.XX.27
M24x1.5

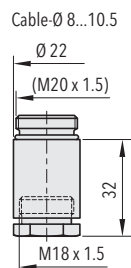

9XX.XX.XX.XX.XX.40
M18x1.5

Switching differential typ. @ 25°C

Measuring range bellows sensor	[mbar]	20 ... 250	30 ... 400	40 ... 600	50 ... 1000
Microswitch 10: Switching differential not adjustable	[mbar]	2	2	6	6
Microswitch 11/21/23: Switching differential not adjustable	[mbar]	5	5	15	15
Microswitch 26: Switching differential not adjustable	[mbar]	10	10	35	35

Electrical data switch

Type	Features	Rating	
		Resistive Load (Inductive Load)	
		AC	DC
10	Small switching differential (not recommended for applications under vibrations)	125 V 10 (1.5) A 250 V 10 (1.25) A	250 V 0.2 (0.02) A 125 V 0.4 (0.03) A 30 V 2 (1) A 14 V 15 (2.5) A
11	Average switching differential, standard vibration resistance	125 V 15 (1.5) A 250 V 15 (1.25) A 500 V 10 (0.75) A	250 V 0.25 (0.03) A 125 V 0.5 (0.05) A 30 V 6 (1.5) A 14 V 15 (1.5) A
23	Average switching differential, increased vibration resistance	125 V 15 (1.5) A 250 V 15 (1.25) A 500 V 10 (0.75) A	250 V 0.3 (0.05) A 125 V 0.6 (0.1) A 30 V 15 (1.5) A 14 V 15 (1.5) A
26	Large switching differential, high vibration resistance	125 V 15 (1.5) A 250 V 15 (1.25) A 500 V 10 (0.75) A	250 V 0.3 (0.2) A 125 V 0.75 (0.4) A 30 V 15 (1.5) A 14 V 15 (1.5) A
21	With gold plated contacts, standard vibration resistance	24 V 0.1 (0.1) A 12 V 1.0 (1.0) A 5 V 2.0 (2.0) A	24 V 0.1 (0.1) A 12 V 1.0 (1.0) A 5 V 2.0 (2.0) A

Electrical connection

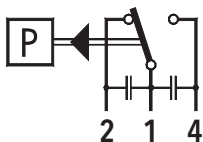

Switch 10/11/23

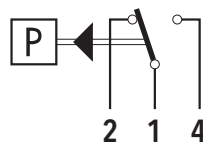

Switch 21/26